

LOREX®

HD Wire-Free Security System

1 / 2

L222A8 Series
English Version 1.0



Scan for Lorex Cirrus APP

Quick Connection Guide
lorex.com



Package Contents

* Per camera in multi-camera packs

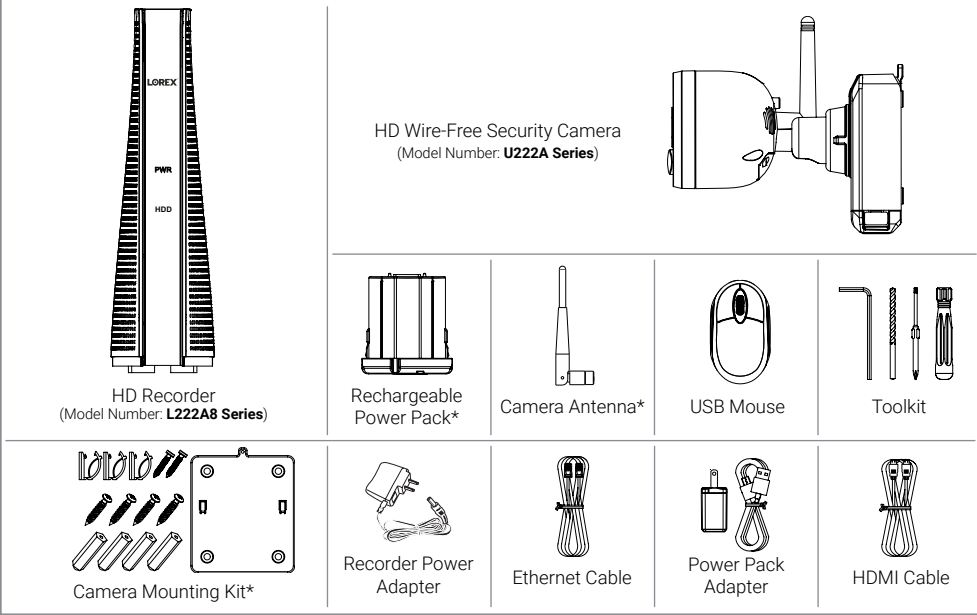

Dimensions

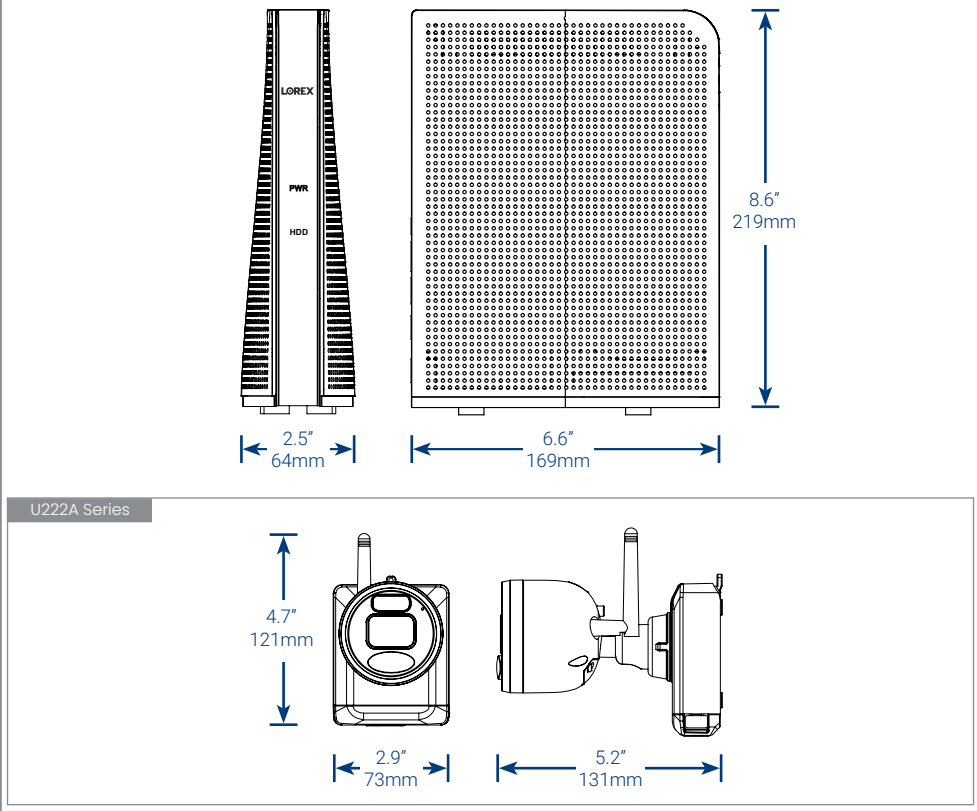

STEP 1: Initial Setup

Before you begin, you will need to prepare the wire-free cameras and Power Packs.

NOTE: Power Packs come fully charged.

To prepare the cameras:

1. Twist the adjustment ring near the camera base counterclockwise to loosen and reposition each camera as shown to the right. Connect one of the white antennas to each camera.

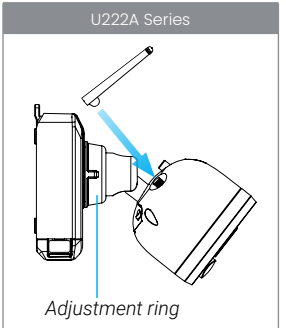

2. Peel off the **PLEASE REMOVE** label covering the contacts on each Power Pack. Insert the charged Power Packs into each camera base. Push up until the Power Pack 'clicks' firmly into place.

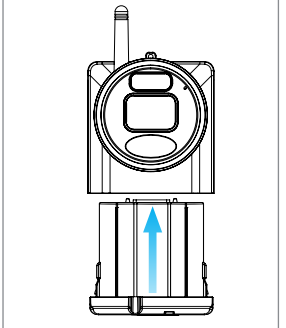

NOTE: The camera will 'beep' when the Power Pack is properly inserted. If you do not hear this alert, remove the Power Pack by pushing on the release tabs* then re-insert.

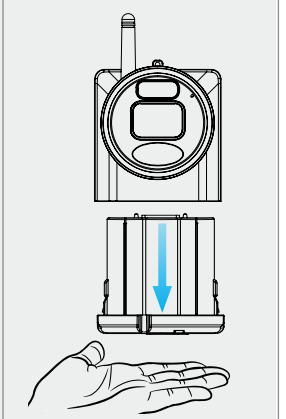
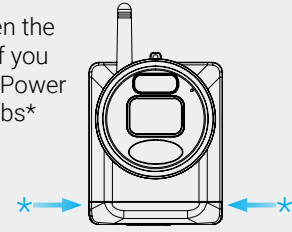

STEP 2: Setting Up the Recorder

Next, you must set up the recorder and connect it to your network.

To set up the recorder:

1. Connect the recorder to your router using the included Ethernet cable.
2. Connect the included power adapter to the recorder.

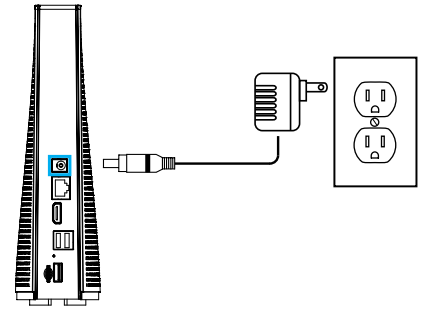
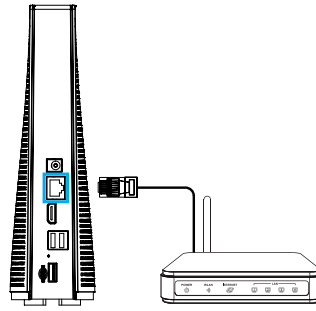

OPTIONAL: Full Recorder Setup

- This guide describes basic setup of the recorder only. This installation is intended for users who wish to monitor their system using the free Lorex Cirrus app on their smartphone or tablet.
- You may choose to use the recorder interface to control your wire-free security system. Connect the included USB mouse to one of the USB ports labelled **Mouse / Backup**, and connect a monitor using the included HDMI cable. See the included **Quick Reference Guide** for details.

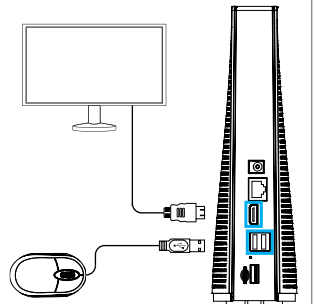

STEP 3: Connecting with Lorex Cirrus

Connect to your system using the free Lorex Cirrus app for smartphones and tablets (iOS and Android).

To connect with Lorex Cirrus:

1. Download and install the free **Lorex Cirrus** app from the App Store or Google Play Store (Or scan QR code on the front page).
2. Tap the Lorex Cirrus icon to launch the app.
3. Tap to open the menu. Tap **Devices**, then tap **Add**.



4. Enter the following:

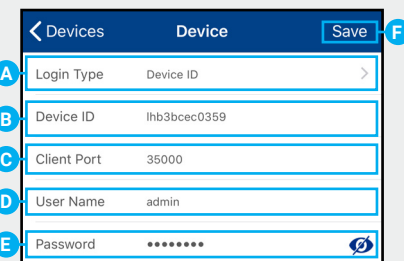

- A Ensure **Device ID** is selected.
- B Tap to scan the QR code on the back of your recorder using the camera on your mobile device.
- C Ensure the **Client Port** reads **35000**.
- D Enter the username (default: **admin**).
- E Enter the password (temporary: **00000000**).
- F Tap **Save**.

5. Enter a **new, secure 8-15 character password**. This password will be used to connect to your system from now on.

Record your password below and store in a secure place:

Need Help?

Visit us online for up-to-date software and complete instruction manuals

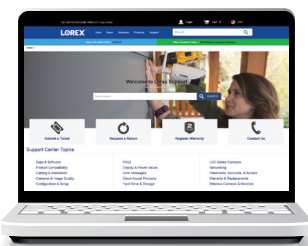

- 1 Visit lorex.com
- 2 Search for the model number of your product
- 3 Click on your product in the search results
- 4 Click on the **Downloads** tab

Copyright © 2020 Lorex Corporation

As our products are subject to continuous improvement, Lorex reserves the right to modify product design, specifications and prices, without notice and without incurring any obligation. E&OE. All rights reserved.



STEP 4: Pairing the Cameras

Next, you must pair each camera to your recorder. You can pair cameras using the Lorex Cirrus app, or with the recorder.

To pair cameras with Lorex Cirrus:

1. From Live view, tap any free channel you would like to pair a camera to (marked with a  icon).
2. Tap **PAIR**. A timer for 30 seconds appears.
3. Press and hold the pair button on the back of the camera for 3 seconds.

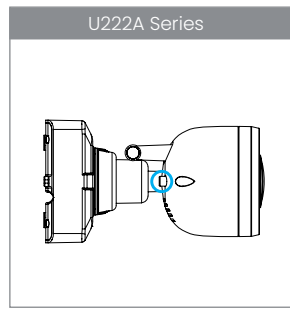
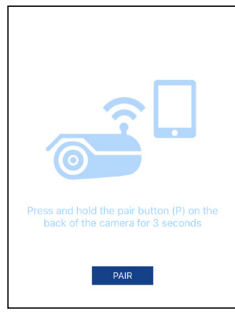
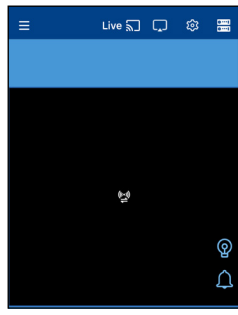

NOTE: A "pairing successful" message should appear on screen. If you do not see this message, repeat the steps above.

To pair cameras using the recorder:

- Hover the mouse pointer near the top of an empty channel and click .
- You will then have 30 seconds to press and hold the pair button on the back of your camera (shown above).

NOTE: If you do not see video from one or more cameras, ensure you have removed the **PLEASE REMOVE** label from the Power Pack. If the issue persists, see the "Troubleshooting" section.

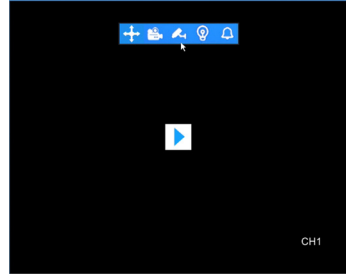

Installation Tips

Follow the tips below for more accurate motion detection and to optimize battery life:

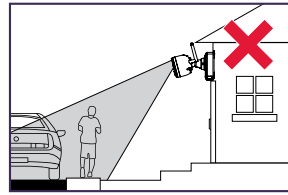
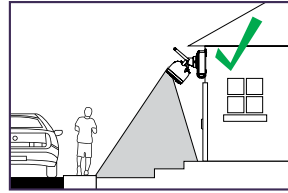

- **See images to the right for ideal setup.** It is recommended to place your camera at least 7ft (2.1m) above the ground and angle it slightly downward toward the monitoring area, excluding any busy areas (e.g., sidewalks or roadways).
- Ensure the camera image is free of obstructions (e.g., tree branches).
- Position the camera no more than 20ft (6.1m) away from the area you wish to monitor.
- See the "Optimizing Motion Detection" section to customize motion settings for each camera on your system.
- For best performance, position the camera so that objects of interest will move from side-to-side across the camera image, rather than moving towards or away from the camera.
- Install the camera within range of the recorder (noted in the camera's specifications).
- Test your camera's connection to the recorder prior to selecting a permanent mounting location.
- This camera is weather resistant for outdoor use (IP66 rated). Installation in a sheltered location is recommended.
- **Battery life will vary based on temperature, settings and number of events.**



Optimizing Motion Detection

Customize motion detection settings to ensure motion events are being recorded and reduce false alarms.

To optimize motion detection:

1. Launch the **Lorex Cirrus** app.
2. Tap a channel in Live View to select it.
3. Tap , then tap **Motion Settings**.
4. Configure the following as needed:
 - Sensitivity:** The amount of motion needed to trigger recording (e.g., higher sensitivity requires less motion to trigger recording).
 - Detection:** Enable/disable motion detection or person detection per channel.
 - Area Selection:** Configure the active area for motion detection so that only areas of interest are selected and detected.
 - Distance Setting:** Configure distance setting for motion detection. While watching the camera's video on your mobile device, recreate a motion event in front of your camera. The icon will change from  to  when motion is detected by the camera. Change the distance setting if motion detection is being triggered by unwanted events.
NOTE: Distance will be affected by temperature.
 - Buzzer:** Set the recorder to sound an alarm when motion is detected.
5. Tap **Save** when finished. Repeat for other cameras on the system.

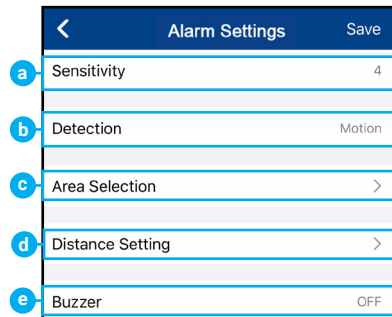

Available Accessories

The following accessories are available for purchase. Visit lorex.com and search for the model numbers below for details:

COLOR	Wire-Free Add On Cameras	Extra Power Pack Power Adapters	2-cell Accessory Power Pack	3-cell Accessory Power Pack PLUS	Solar Panel
WHITE	U222A	ACPWF1	ACBATTR2	ACBATTR3	ACSOL1B

Charging the Power Pack

Connect the included power adapter to the micro USB port on the Power Pack.

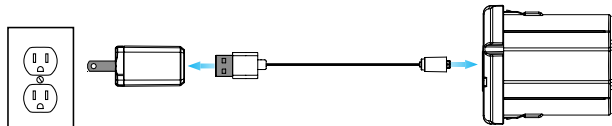

IMPORTANT

The Power Pack LED flashes red while outside the safe charging temperature of 32-113°F (0-45°C). In this state, the camera remains powered up, but **the Power Pack will not charge outside the safe temperature range.**

Power Pack	Charge Time
2-cell	Approx. 6 hours
3-cell	Approx. 8 hours

LED Color	Meaning
Green	Fully charged
Red	Currently charging

STEP 5: Installing the Cameras

Follow the instructions below to mount the cameras. It is recommended that you refer to the "Installation Tips" section to help you select good mounting locations.

To install your cameras:

1. Set the mounting bracket in the desired mounting position. Mark holes through the mounting bracket (shown as blue X's on the right).
2. Drill holes where marked for the mounting screws using the included drill bit (item C in toolkit).

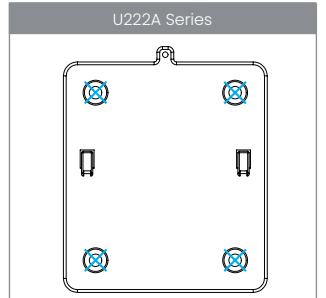

3. Secure the bracket to the mounting surface with the included mounting screws (x4). Make sure all screws are fastened tightly using the included screwdriver (item A+B in toolkit).

NOTES:

- Insert the included drywall anchors if you are mounting the camera onto drywall.
- The hole at the top of the mounting bracket will be used in step 5, once the camera is attached to the mounting plate.

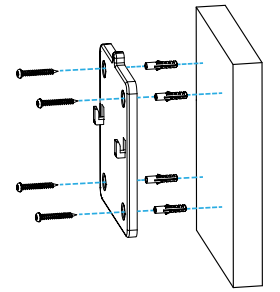

4. Lower the camera base onto the mounting bracket so the 2 tabs in the mounting bracket lock into the 2 slots in the camera base.

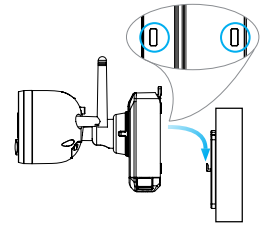

5. Insert the security screw through the fasteners on the top of the camera base and mounting bracket to secure the camera to the mounting bracket. Tighten using the included screwdriver (item A+B in toolkit).

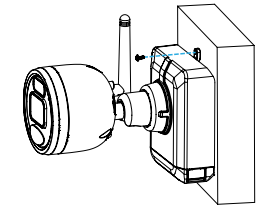

6. To prevent the pre-installed locking screw from being easily removed, tighten it on the base of the Power Pack using the included screwdriver (item A+B in toolkit).

NOTE: You will need to loosen the locking screw to remove the Power Pack in the future.

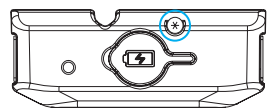

7. Adjust the angle of the camera. Twist the adjustment ring counterclockwise to reposition the camera. Tighten the adjustment ring when finished.

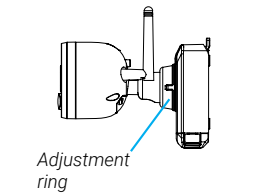

8. **OPTIONAL:** Use the included cable clips to complete the installation. Remove the protective strip to uncover the adhesive on the cable clip to attach to the mounting surface.

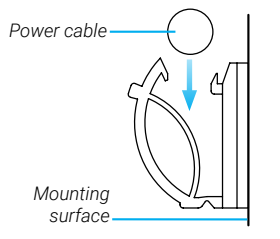

ATTENTION:

This camera includes an Auto Mechanical IR Cut Filter. When the camera changes between Day/Night viewing modes, an audible clicking noise may be heard from the camera. This clicking is normal, and indicates that the camera filter is working.

Troubleshooting

Problem	Solution
No picture / signal	<ul style="list-style-type: none"> • Ensure the camera is connected to a compatible recorder. For full camera compatibility, visit lorex.com/compatibility. • Ensure the Power Pack is properly inserted into the camera base. • Ensure you have removed the PLEASE REMOVE label from the Power Pack. • Ensure you have completed the camera pairing process described in "STEP 4: Pairing the Cameras". • Connect the power adapter to your Power Pack to ensure it is charged. The LED on the Power Pack glows green for full charge, or red for less than full charge. • Remove obstructions between the recorder and camera. Materials such as brick, concrete and wood can significantly impact the wireless signal strength. • Try repositioning the camera, recorder, or both to improve the reception.
Battery life is too short	<ul style="list-style-type: none"> • Ensure the camera is not pointing at a high-traffic area. Position the camera so it only captures areas of interest with no high-traffic areas (e.g., a busy sidewalk or roadway) visible in the image. • Live video is being viewed too frequently. Viewing live video often will impact battery performance. • Ensure you have set an active area and distance setting for motion detection to reduce false alarms. See "Optimizing Motion Detection" for details. • Battery life will vary based on temperature, settings and number of events. • Make sure to fully charge the battery. The LED light will turn from red to green to indicate when the battery is full.
Picture is dropping	<ul style="list-style-type: none"> • Move the camera closer to the recorder. • Try repositioning the camera, recorder, or both to improve the reception.
Picture is or has become choppy	<ul style="list-style-type: none"> • Move the camera closer to the recorder. • Remove obstructions between the recorder and camera.
Camera is not detecting motion	<ul style="list-style-type: none"> • Your camera may be too far away from the area of interest. Try to keep the camera within 20ft (6.1m) of the area you want to monitor. • Review the "Installation Tips" and "Optimizing Motion Detection" sections to ensure your camera is installed in an optimal location and motion detection is properly configured.
Picture is too bright	<ul style="list-style-type: none"> • Ensure your camera isn't pointed directly at a source of light (e.g., sun or spot light). • Move your camera to a different location.
Night vision is not working	<ul style="list-style-type: none"> • The night vision activates when light levels drop. The area may have too much light.
Picture is not clear	<ul style="list-style-type: none"> • Check the camera lens for dirt, dust, spiderwebs. Clean the lens with a soft, clean cloth. • Too much environmental interference will affect picture clarity. Move the camera to a different location.
Bright spot in video when viewing at night	<ul style="list-style-type: none"> • Night vision reflects when pointing a camera through a window. Move the camera to a different location.