

LIVE WITH
i ILVE

**BUILT-IN COOKTOP OPERATING &
INSTALLATION MANUAL**





OPEN 24/7
ILVE ACCESSORIES ONLINE SHOP

For a wide range of coffee machines and other genuine
ILVE accessories at the click of a button
shop.ilve.com.au

As a part of our continued customer service offering, you can now register your ILVE products online at <https://support.eurolinx.com.au/#/form/warrantyregistration>

Just follow our simple online registration process.

Please ensure that you always keep your proof of purchase in order for your warranty to remain valid should you ever need to use it.

As always, you can contact us on
1300 856 411

iWarranty

REGISTER YOUR WARRANTY ONLINE NOW

GO TO: <https://support.eurolinx.com.au/#/form/warrantyregistration>

Congratulations,

you are now the proud owner of an ILVE cooking appliance. Thank you for purchasing ILVE and welcome to the exciting world of cooking the ILVE way.

This instruction manual has been specially created to inform you of the full range of features your ILVE appliance has to offer and serves as an introduction to the wonderful benefits of ILVE's dynamic cooking systems.

We present detailed information on each of the advanced cooking systems built into ILVE appliances. Once you have read this section you will be able to choose the most appropriate settings for your appliance when cooking different types of food.

We ask you to read the instructions in this booklet very carefully as this will allow you to get the best results from using your appliance. **KEEP THE DOCUMENTATION OF THIS PRODUCT FOR FUTURE REFERENCE.**



Safety Precautions	8	Adaptation to Different Types of Gas	22
Operating Instructions	9	Installation Instructions	24
Operating - Gas Cooktop	10	Ancillary Service Information	26
Tepanyaki Plate (Fry Top)	12	Guarantee	27
Electric BBQ (Lava Grill)	14	Cleaning, Care & Maintenance	29
Ceramic Electric Hot Plate	16	ILVE Cooktop Recipes	30
Cooktop Installation Instructions	18	Warranty Information	36
Installation - Gas Supply	20	Trouble Shooting Guide	38
Installation - Electrical Supply	21		

SAFETY PRECAUTIONS

Before installing and operating the hotplate, read these instructions completely and carefully.

IMPORTANT To be installed only by an authorised person

- Remove all packaging material and literature from the hotplate before connecting the gas and electrical supplies

INSTALLATION

- Observe all governing codes e.g. AS5601, council ordinances and local authority rules.
- The hotplate must be installed by an authorised person
- The hotplate must be grounded
- Save these instructions for the local inspectors use

TO THE INSTALLER

- After connecting the gas supply, turn on the gas and check for leaks at all joints with soapy water or other approved methods

UNDER NO CIRCUMSTANCES USE A NAKED FLAME IN CHECKING FOR LEAKS. NOT FOR USE IN MARINE CRAFT, CARAVANS OR MOBILE HOME UNLESS EACH BURNERS IS FITTED WITH A FLAME SAFE GUARD

OPERATING INSTRUCTIONS

WARNINGS

Before using the cooker, read the instructions booklet carefully. This contains very important information concerning safety during installation, use and maintenance. The instructions booklet must be kept with care for later consultation.

Do not use or store flammable materials in the appliance storage drawer or near this appliance.

Do not spray aerosols in the vicinity of this appliance when it is in operation. Where this appliance is installed in a marine craft or in caravans, it shall not be used as a space heater.

Do not modify this appliance.

If the hotplate fails to operate correctly, contact Eurolinx Pty Ltd or their appointed agent for service.

DO NOT ATTEMPT REPAIRS YOURSELF; repairs and servicing shall only be carried out by Authorised Personnel.

This appliance is not intended for use by persons (including children) with reduced physical, sensory or mental capabilities, or lack of experience and knowledge, unless they have been given supervision or instruction concerning use of the appliance by a person responsible for their safety.

Children should be supervised to ensure that they do not play with the appliance.

Never place unsteady or deformed pans on the burners or on the electric hotplates as they could overturn accidentally. When placing pans on the hob, always ensure that the handles are facing inward so that there is no risk of knocking against them.

When the cooker is not in use, ensure that all knobs are exactly in position “● / o”

Never leave the hotplate switched on without a pan on it, otherwise it will reach a very high temperature quickly and the cooker or furniture in the vicinity could be damaged.

OPERATING - GAS COOKTOP

LIGHTING BURNERS – simply press the knob in, turn anti-clockwise to maximum, the electronic igniter will spark and ignite the burner. Check that the gas has been lit; if the burner fails to ignite repeat the above process.



● OFF- ● maximum- ● minimum

For models with Flame Failure follow the above procedure but keep the knob fully depressed for up to 10 seconds after ignition to allow the safety to lock in. Check that the gas has been lit; if the burner fails to ignite repeat the above process. If the burner still fails to ignite, a match or lighting device can be used, but care must be taken. Keep igniters dry. If the problem persists, contact Eurolinx Pty Ltd or their appointed agent for service.

DO NOT TOUCH HOT SURFACES, ALLOW HOB TO COOL BEFORE WIPING SPILLAGE.

PRACTICAL HINTS FOR USE

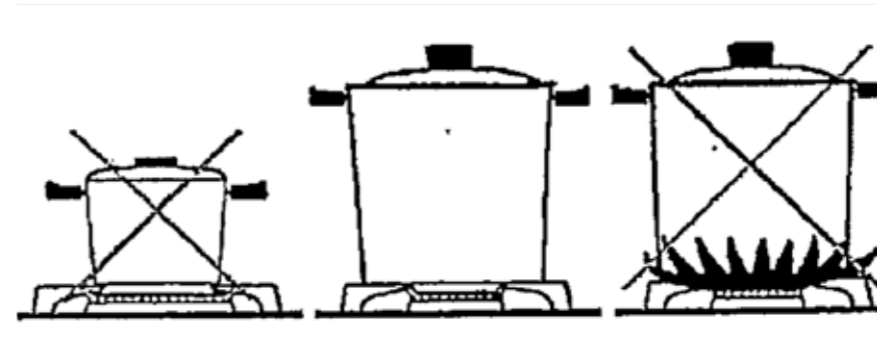

WARNING

Do not use pots which exceed the width of the trivet (the trivet is the frame with fingers that the pot sits on). If pot size exceeds the edge of the trivet, flames could cause damage to work surfaces either side of the burner. Do not use pots which are too small for the burner size, they become unstable on the trivet.

Always use a vessel for cooking that is appropriate in size for the size of burner. Never use pots that are too small or too large. For wok cooking it is recommended that a domestic size wok, no larger than 400mm in diameter be used.

Always use the small star trivet for pots with a base smaller than 100mm.

Use a strong flame to bring liquids to boil, seal meat and generally for all food which must be cooked rapidly i.e. when using a wok.

Use a low flame for sauces or stews.

Do not cook food over too strong a heat. Boiling food fast does not cook any faster but violently stirs up the food causing it to lose flavour.

TEPANYAKI PLATE (FRY TOP)

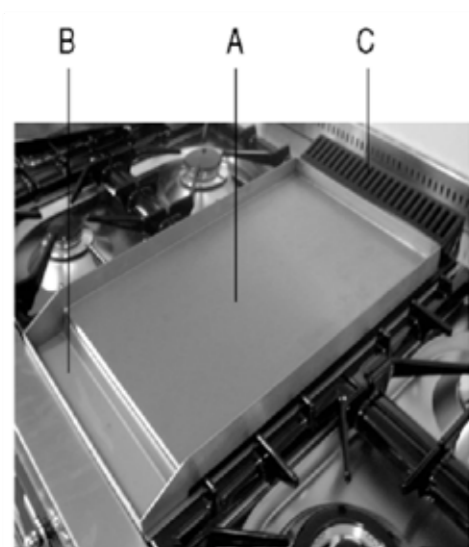

Figure 1



- A = cooking tray
- B = drip tray
- C = exhaust flue for combustion fumes

The Fry-Top is composed of a special stainless steel plate (8mm thick), specially designed to have temperatures evenly distributed over the whole surface so that you can utilise the complete cooking surface. The plate also has hygienic advantages.

Another advantage is the high heat accumulation of the plate, with very low heat loss. To use the appliance, light the flame below the plate by means of the corresponding knob (see “Lighting the burners”) and ensure that the flame is burning.

Leave the knob in this position for about 10 minutes at the most and wait for the plate to heat up. Once this period has elapsed, the plate is ready to start cooking.

By adjusting the flame, there is no limit to your culinary imagination. If you turn the knob to minimum, you can do slow cooking or types of cooking in which you want to maintain the organic properties of the foods. Higher temperatures are suitable for cooking meat, fish and vegetables.

The Fry-Top plate is ideal for Japanese Tepanyaki cooking: the special lid needed for this type of Oriental cooking is available as an optional accessory.

Some models are supplied with the spatula shown in above, which is useful for both cooking and for cleaning the plate.

Control Knob Settings

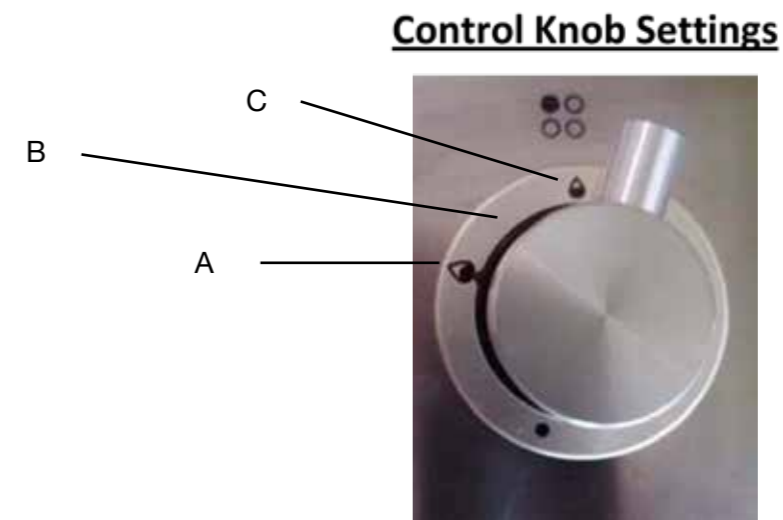

A = Max - B = Med - C = Min

COOKING TABLE

(purely indicative values after 10 minutes of preheating with the burner at maximum power)

KNOB POSITION	TYPE OF COOKING
B	egg's in 2 minutes
B	sliced eggplant (0.5cm thick) from 9 to 13 minutes
B	sliced potatoes from 5 to 7 minutes
B	sliced courgettes from 3 to 5 minutes
B	fish (portions of about 200g) in 15 minutes
B	steak in 3 minutes
A	T-bone steak (2cm thick) in 5 minutes

CLEANING AND CARING FOR THE TEPANYAKI PLATE

Allow the tepanyaki plate to cool slightly and pour on white vinegar. Allow to sit for five minutes then scrape the plate with a flat spatula. For heavy build up a scourer may be required.

ELECTRIC BBQ (LAVA GRILL)

The Lava Stone BBQ allows you to BBQ meats and fish without the use of oils. The lava stones placed under the electric element enable a constant temperature (250°C) and the absorption of fats without smell and vapor. The grid, tray and lava stones are easily removed for cleaning. Before turning on the appliance, check that all parts are well installed. To turn on the BBQ rotate the knob to the desired setting between “1” and “12”; the indicator light will be illuminated, indicating that the appliance is working. When the knob is turned to the “0” position the appliance is turned OFF and the indicator light will go out. Important: To grill, we recommend pre-heating the grill element and lava stones for approximately 10 minutes on position “12”, this allows the lava stones to reach the required temperature to vaporise the fats and liquids from the meat to enhance the flavour of the produce being cooked.



Cooking Table

Table for grilling on lava stones		
Dishes	Position	Time in min.
Sausages	12	13
Steaks	12	12
Hamburgers	12	14
Filet steak	12	8
Liver	12	5
Lamb cutlets	12	8
Chicken steaks	12	9
Chicken drumsticks	12	17
Sliced salmon	12	10
Trout	12	12
Trout cooked in foil	12	30-35

CARING AND CLEANING FOR YOUR LAVA STONE BBQ

Before cleaning, disconnect the appliance from the mains. Cleaning must be carried out when the appliance is cold. Remove all the removable parts. Remove the grid, lift the heating element and take away the hob bed with lava stones. Stainless steel parts must be cleaned with water and detergent, then dry with a soft cloth carefully. Under no circumstances use corrosive or abrasive detergent, this could damage the appliance. Stainless steel, brass or copper parts must be treated by using the proper products, thus keeping the brightness for a long time.

Control Panel and aluminium parts must be cleaned by means of de greasing detergent.

To clean the Lava Stones, you can wash them gently in hot soapy water and then allow them to dry well before re-use. Alternatively, you can put them into a stocking or perforated sleeve/cloth, place them on the top basket of your dishwasher and use a hot wash cycle with NO powder.

CERAMIC ELECTRIC HOT PLATE

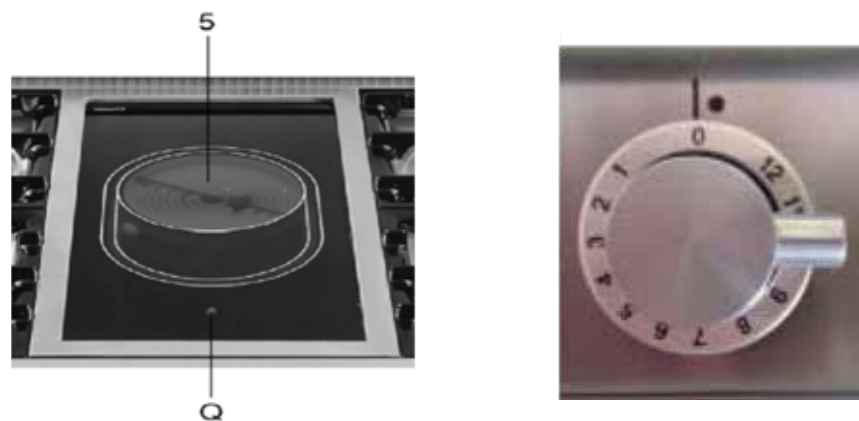

INSTRUCTIONS FOR USE OF THE ELECTRIC PLATE

The vitreous ceramic electric plate (5) is controlled by a knob (as above energy regulator). A pilot light comes on as soon as the heating element is activated. The control knob is graded from 0 to 12. Position 0 indicates that the corresponding cooking area is switched off. Position 1 indicates that the corresponding cooking area is at the minimum power, while position 12 indicates that the cooking area is at maximum power.

The energy regulator controls the cooking area with two circuits (5). When the knob is turned clockwise from position (off) to the desired position (1-12), the primary part of the cooking area is switched on. To switch on the secondary part, turn the knob to position 12 and then turn it past position 12 as far as it will go in a clockwise direction. At this point the secondary circuit switches on and it is possible to vary the power from 1 to 12 (1 = minimum, 12 = maximum).

RESIDUAL HEAT WARNING LIGHTS

There is a residual heat warning light (Q) on vitreous ceramic hob. Its purpose is to increase the safety of the appliance because when it is lit it indicates that the cooking area is still very hot. The residual heat warning light stays lit even after the cooking area has been switched off to warn you that it is still hot.

Important: The ceramic hob cooking surface remains hot for a long time after use. Do not touch the hob with your hands or let children near it. The residual heat indicator will remain lit until the hob has cooled down. If any cracks appear in the ceramic hot, disconnect the appliance immediately from the mains and call an authorized technical service centre.

ELECTRIC HOTPLATE

For efficient use and low energy consumption, it is advised to use pans specifically designed for electric cooking on ceramic hobs. The bottom of the pan must be thick and flat. Its diameter must be as similar as possible to that of the cooking ring. The surface of the hob and the bottom of the pan must be kept clean.

- A** – Do not leave the hotplate switched on without a pan
- B** – Do not wet or overheat the plates
- C** – Avoid sudden changes of temperature on the ceramic hob. For example, do not pour cold water onto the hot hob.

- D** – Ensure that the pan covers the whole cooking area.
- E** – The bottom of the pan must be flat and dry so as to use less energy and keep your ceramic hob in good condition.
- F** – Do not leave the pan handles sticking out as they could be knocked over accidentally.
- G** – Do not forget that the cooking area remains hot for quite a long time even after it has been switched off. Make intelligent use of this characteristic by switching off the cooking area a few minutes before completing cooking. The residual heat that has been accumulated in the ceramic will thus enable you to complete cooking without using more electric power.
- H** – It is preferable not to cook on the ceramic hob with pans that have been used on gas burners. The flames may have deformed the bottom of the pans. Do not use aluminium pans on your ceramic cook top as this metal is very soft and can damage and/or permanently stain your cook top.

Cooking Table - (The following table is a guide only to settings for a variety of foods.)

Knob position	Type of cooking
1-2	melting butter, chocolate, etc
3-4	heating small amounts of liquids, keeping food warm, preparing sauces
5-6	heating solid foods, thawing frozen foods, omelettes with 2-3 eggs, fruit and vegetable
7-8	cooking with meat and fish, pulses in sauces, dishes with water, making jam
9-10	roasting meat or fish, steaks, liver, eggs
11-12	boiling large amounts of water, frying chips, etc

CLEANING THE CERMAIC HOB

The flat surface of the ceramic hob makes it considerably easier to clean than traditional hobs. Clean the hob in the same way as any glass surface in your home. Never use abrasive products. Routine cleaning must be carried out when the hob is cold. Caution: take care not to drop substances containing sugar on the hob during operation. If this should happen, immediately turn off the respective heating element and clean with warm soapy water before the glass cools. When performing this special cleaning, take particular care not to burn yourself.

We recommend cleaning the cooking top once it has cooled down. The stainless steel and painted parts must be cleaned with lukewarm water and anti-corrosive liquid detergents. Dry the parts with a soft cloth.

Never use steel wools or abrasive detergents. To keep the surface clean, we recommend Hillmark Cerapol or Ceraseal alternatively, detergents or similar products. The instrument panel and all the aluminium parts must be cleaned only with alcohol or de greasing products. Never use lemon on MATT / GRAPHITE.

COOKTOP INSTALLATION INSTRUCTIONS

GENERAL

1. The requirements of local Gas and Electrical authorities must be adhered to, Consult AG 601 / ASNZS 5601 and SAA Wiring Rules as appropriate
2. Location of gas inlet- At rear of the cook top located on the right, left or centre depending on the model (Refer to model specifications)
3. Electrical connection - 240mm C/L from RH side (as viewed from front) 40mm C/L from rear Connection is by means of flexible cord and plug to 10 amp GPO
4. Overall dimensions of hotplate - Refer to dimensions chart in following pages
5. Eurolinx Pty Ltd and their appointed agents decline any responsibilities in the case of installation not according to these instructions.

HOTPLATE CLEARANCES

The hotplate is to be installed as detailed below When the hotplate is installed abutting a side or rear wall, the wall must be of non-combustible material, eg ceramic tiles.

The following minimum clearances to combustible materials must be observed: Minimum clearance from hotplate edge to side wall must be 200mm.

Minimum clearance from hotplate edge to rear wall must be 200mm

Minimum clearance from hotplate to cupboard above hob burners must be 600mm

Range hoods and overhead exhaust fans must be installed according to the manufacturers' instructions but in no case shall clearance from hob burners be less than 600mm for the range hood and 750mm for the overhead exhaust fan.

It is recommended that the adjacent kitchen surfaces should be capable of withstanding temperatures of 100°C

FITTING THE COOKING HOB ONTO THE BASE UNIT WITH DOOR

The unit must be made in such a way that the flames are not blown out if the doors are opened or closed rapidly. The bottom of the cooking hob must not be subject to depression or pressure when the doors are opened or closed. We advise working as shown in figure A). The panel under the hob must be easy to remove for maintenance purposes.

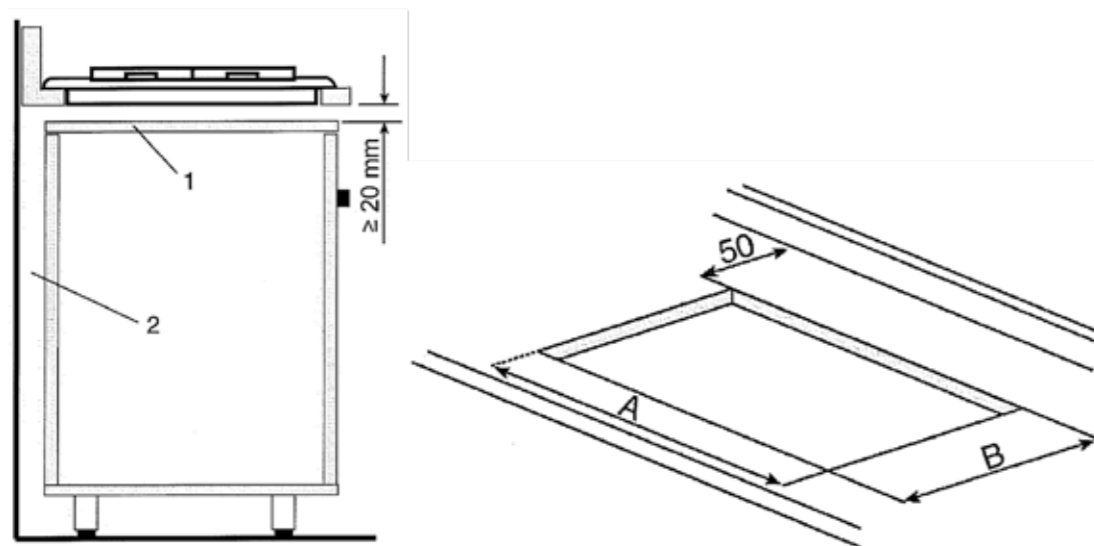

Figure 1

Cut Out Dimensions for Built-in H / HF Series

Mod	H30	H360	H60	H70	H38	H39	HF40
A	270	555	555	555	755	835	360
B	475	475	475	475	475	475	490

Cut Out Dimensions for Built-in HP / XLP Series

Mod	HP45	HP65	HP95	HP75	HP125	HP1230	XLP90
A	380	570	850	680	1130	1120	875
B	481	485	485	490	480	300	570

Overall Dimensions for P Series Freestanding

Mod	P665	P965	P1265
A	600	900	1200
B	650	650	650
Height	85	85	85

BUILT-IN INSTALLATION

To avoid liquid infiltrations under the working tops, it is necessary to apply a gasket which is supplied with the top. The fixing to the furniture is carried out with clamps assembled on the appliance as per Figure 2. For Freestanding cooking hob models (P665, P965, P1265) must be installed with the top of the hob level with the bench and must support a minimum weight of 100 kg.

Figure 2

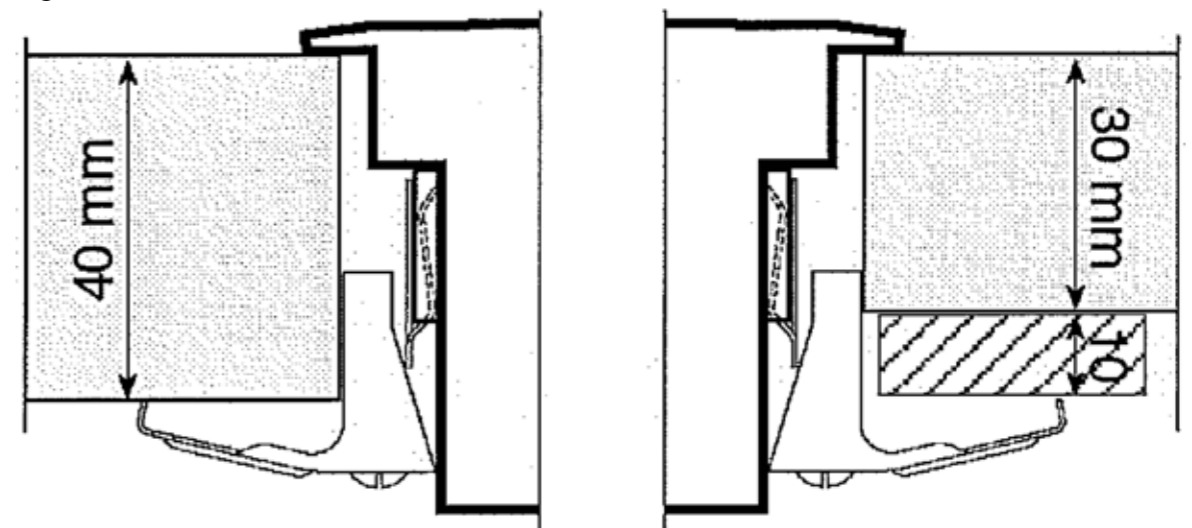

INSTALLATION - GAS SUPPLY

These technical instructions have been prepared for use by Authorised persons. This unit must only be installed by an Authorised person. The installation must be carried out by qualified personnel in accordance with the relevant requirements of the Gas Safety Regulations, the local Building Regulations.

Gas connection

Gas-powered devices for home use, which are not connected to a conduit for the evacuation of combustion products, must not cause a concentration of carbon monoxide that could pose a health risk to the persons exposed in relation to the time of exposure. We recommend checking that the appliance is properly set up for the type of gas distributed. The connection to the gas pipes must be made in a workman like manner, in compliance with current standards that prescribe the installation of a safety tap at the end of the pipe. The Gas Connection is male 1/2" BSP and is situated at the right hand rear of the appliance.

During installation ensure that the flexible connection be located so as to prevent excessive operating temperatures affecting the hose. Under no circumstance is the temperature of the flexible connection to exceed its approved rating. The flexible connection should also be checked visually for any abrasion, defect or kinking and replaced or repositioned to prevent abrasion, kinking and permanent deformation if necessary. Always ensure that a restraining chain, if fitted, be correctly fitted so that strain is not placed on the household plumbing.

It is recommended that an isolating valve and union be fitted, to enable simple disconnection for servicing. These are to be in an accessible location.

Natural Gas

The appliance is factory set for Natural gas and is supplied with a 1kPa regulator that must be fitted to the gas supply to the appliance.

ULPG Gas

The ULPG gas pressure regulator must be set to provide a supply pressure of 2.75kPa conforming to standards regulations in force should be fitted. Fit the test point assembly supplied with the appliance to the gas connection when installing for use with ULPG Gas.

It is possible to connect the gas in the following ways:

This appliance is suitable for use with either a flexible connection or rigid copper connection. If installing the appliance with a flexible connection the flexible connection must be Australia Gas Association approved to class B of AS/NZS1869 as a minimum. Using a Plumbezy flexible hose, AGA approval number 6196, 10mm ID, class D and between 1-1.2m long in accordance with AG601 for a "high level connection".

Ensure when fitting the elbow supplied with the appliance that the sealing washer is used to prevent gas leaks.



Warning: on the cooking top, it is forbidden to carry out the gas connection by means of the rubber flexible pipe fixed onto the rubber hose, as it is not possible to inspect the pipe.

Warning: Once the installation has been completed check if there is any gas leakage by using soapy water or other suitable leak detection fluids.

DO NOT USE FLAMES TO CHECK ANY GAS LEAKAGES.

Installation - Electrical Connection

BEFORE CONNECTING THE PLUG INTO THE POWER SOCKET, FOLLOW THESE INSTRUCTIONS

The electrical supply for the upright cooker must be a 240 volt 50 Hz. The fuse and electrical wiring of the home / premises must support the load of the appliance.

The hotplate must be earthed. Connect the hotplate to a properly earthed and rated power socket, as appropriate. The flexible cord of the appliance must not be subject to direct heat and must be positioned after installation of the hotplate so that its temperature does not exceed 75°C.

IMPORTANT if a power socket needs to be installed or relocated, the work must be done by a licensed electrician.

ADAPTATION TO DIFFERENT TYPES OF GAS

The cooking hob is supplied as a natural gas unit and should not require any adjustment of the aeration. If the appliance is ordered and specified as a ULPG gas then it will be converted by Eurolinx prior to dispatch and should not require any adjustment to the aeration. Follow the steps below to convert to LPG and to adjust the aeration of the burners. Remove the pan supports, caps and burners from the hob. Remove the screws from under each burner that are securing the hob to the base and lift top up to gain access to the burner venturie.

Note: Some models that do not have a one piece hob will have securing around the outside edge of the spillage bowl that will also need to be removed to gain access to the underside of the cooking hob.

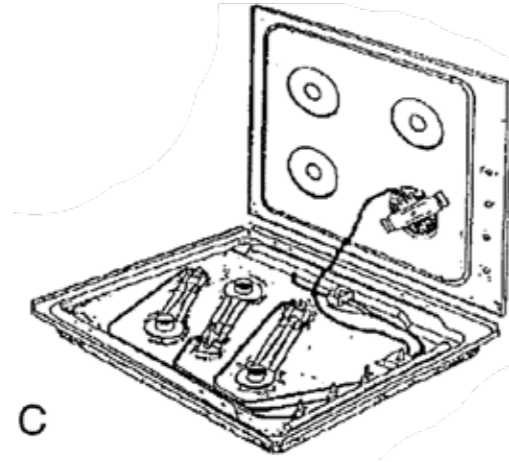

Remove screw "F" and remove air damper "R" Replace the Natural gas injector that is located at entry point of the venturie "U" with the ULPG injector. Use the chart below to identify the correct injector for each type of burner. Replace the air damper "R" and refit screw "F" leave lose to allow adjustment of aeration.

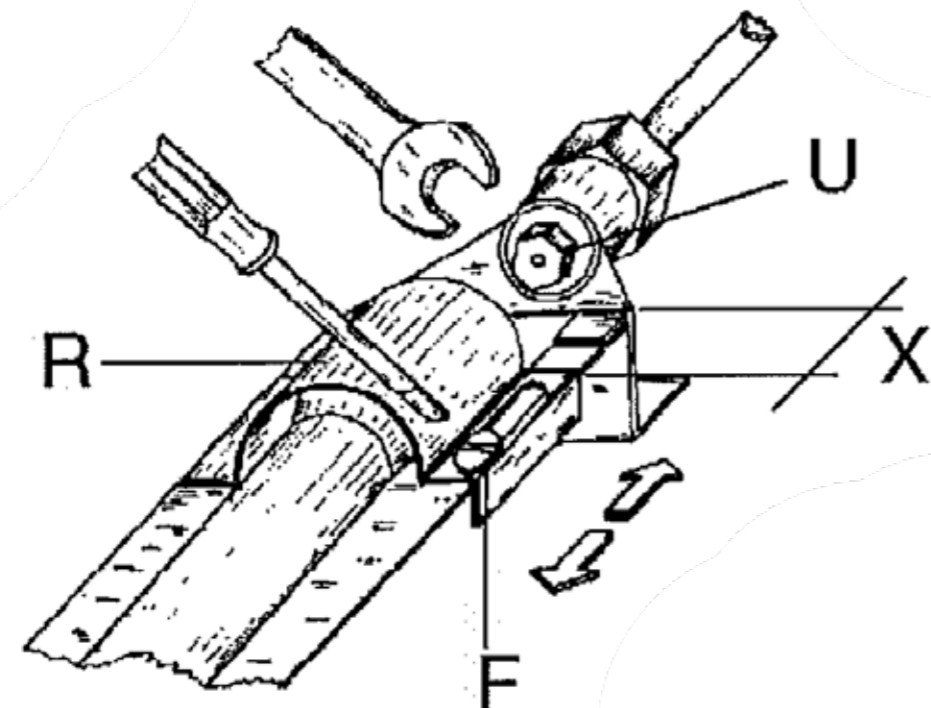

Burners, Injectors & Mega-joules

BURNER	NATURAL GAS			ULPG		
	Inj	Mj/h	Kpa	Inj	Mj/h	Kpa
DUAL WOK	1.60/0.68	14/2.2	1.00	0.86/.040	11.5/2	2.75
SINGLE WOK	1.70	13.8	1.00	0.92	11.00	2.75
LARGE	1.40	10.0	1.00	0.82	9.00	2.75
MEDIUM	1.10	6.2	1.00	0.68	6.00	2.75
FISH / TEPANYAKI	1.60	12.5	1.00	0.85	10.00	2.75

AIR ADJUSTMENT

The air adjustment is to be carried out with the flame at the maximum, with a screwdriver loosen screw "F" and move the cylindrical sleeve "R" towards the injector to decrease the air, move it away from the injector to increase the air. Once the correct aeration is achieved tighten screw "F" to fix the position.

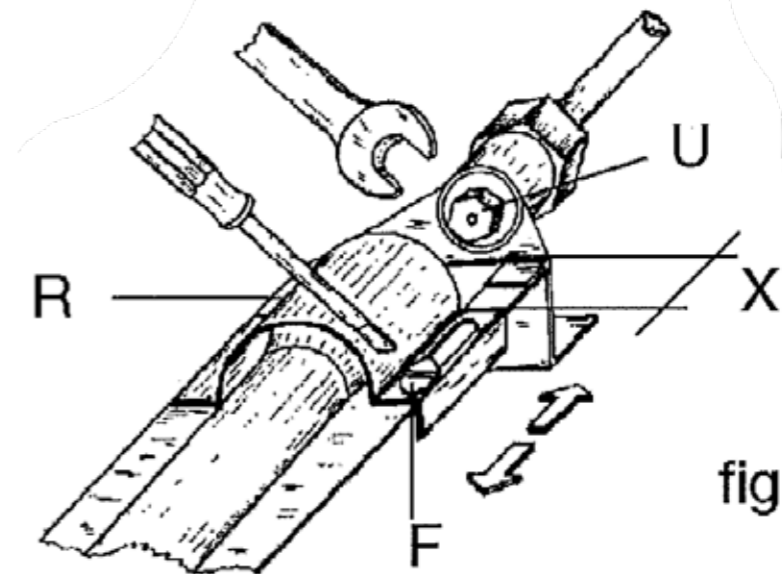

fig. 13

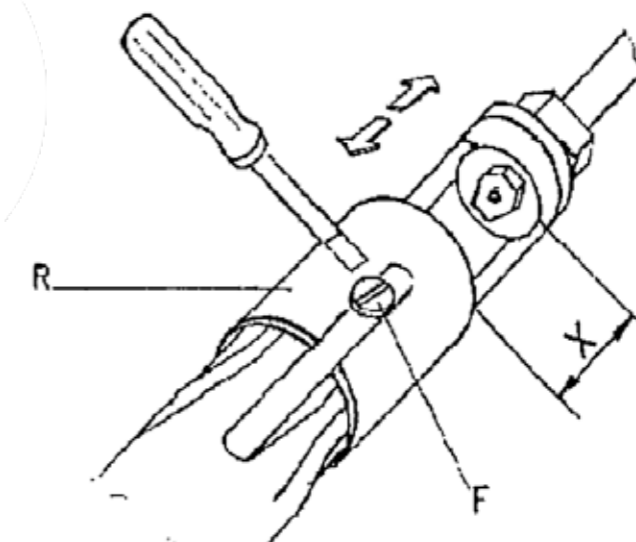

fig. 14

INSTALLATION INSTRUCTIONS

TABLE 2 "X"mm (indicative)

Burner Type	Natural	ULPG
Medium	10mm	10mm
Large /Simmer	10mm	10mm
Single Wok	10mm	15mm- Fully Open
Titanium Single Wok	15mm Inner Fully Open Outer 10mm	15mm- Fully Open
Dual Wok		Fully Open
Fish/Tepanyaki	10	5mm
Oven 90cm	4	20mm
Oven 60cm	6	20mm

Examples:

A. Flame with excess of air: it is small, tight and separated. Move forward the cylindrical sleeve R placed in front of the injector.

B. Flame with lack of air; it is floppy with yellow streaks. Move backward the cylindrical sleeve R placed in front of the injector.

C. Normal flame: its colour is light blue

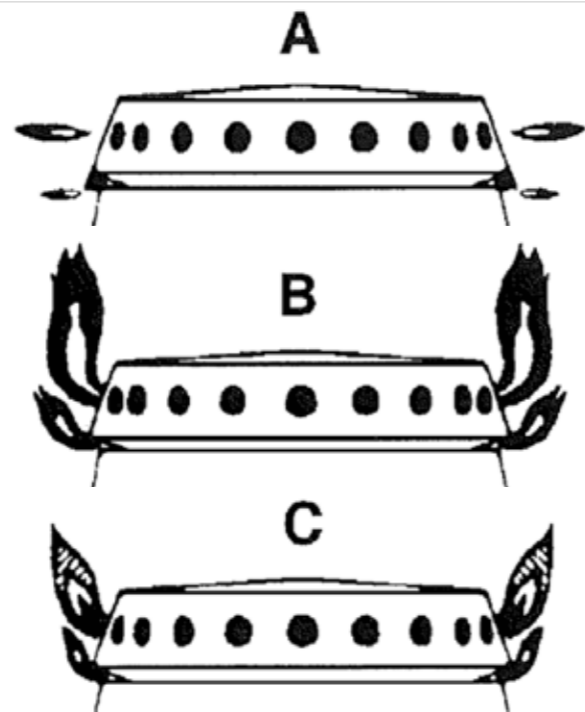

Low Flame Adjustment of Burners

When installing the appliance it is recommended to check that the burner minimum speed (Low Flame Setting) has been correctly adjusted. If it is necessary to change the type of gas, adjustment of the low flame setting must be completed by the installer. To adjust the minimum setting for the burners the following steps must be complete.

Recommended Bypass

(Low Flame Settings) Turns from fully in position

Burner Type	Natural	ULPG
Medium	1/2 - 5/8	Fully In
Large /Simmer	3/4	Fully In
Single Wok	1 3/8	Fully In
Titanium Single Wok	1 3/8	Fully In
Dual Wok	Inner 1/4 Outer 1/4	Inner 1/4 Outer 1/4
Fish	1/4	Fully In
Tepanyaki	3/4	Fully In
Oven 90cm	1/2	1/8
Oven 60cm	3/4	1/4

Minimum flow of cooking hob taps (Figure 1)

- Switch on the burner and turn the control knob towards the minimum flow position;
- Remove the knob;
- Using a screwdriver, adjust the internal screw until the correct low flame is obtained, the screw is located just to the right of the shaft see figure 1
- Refit the knob.

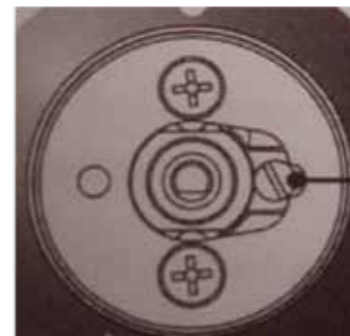

Figure 1

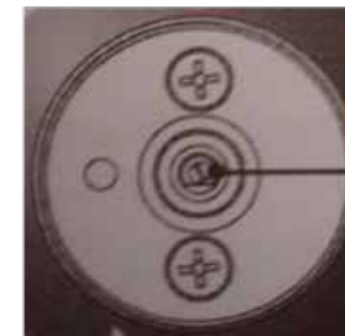

Figure 2

Minimum flow of non-valved cooking hob taps (Figure 2)

- Switch on the burner and turn the control knob towards the minimum flow position;
- Remove the knob;
- Insert a small screwdriver into the shaft of the gas valve and adjust the internal screw until the correct low flame is obtained; see figure 2
- Refit the knob.
- Unscrew the adjustment screw to increase the flow, or tighten it to reduce the flow.
- The adjustment is correct when the low flame measures approximately 3 or 4 mm.
- For ULPG the adjustment screw should be tightened all the way.
- When changing quickly from maximum to minimum flow and vice versa make sure that the flame does not go out.

ENSURE THE MINIMUM FLAME WILL NOT BE EXTINGUISHED BY AIR DRAUGHTS

Check that the igniter for each burner successfully ignites the gas and that the burner remains alight. If an igniter fails to work or a burner fails to remain alight, first remove the plug from the electrical power outlet, and then check that all electrical connections are in place. If the hotplate fails to operate correctly, contact Eurolinx Pty Ltd or their appointed agent for service. When satisfied that the hotplate is operating correctly, instruct the customer in its safe operation. Ensure the customer understands fully by having them operate the hotplate in all its functions.

ANCILLARY SERVICE INFORMATION

GUARANTEE

Pressure Adjustment

First turn the gas off to the appliance. Remove the sealing screw from the regulator's test point at the rear of the appliance and place the hose of the Manometer onto it. Turn the gas on to the appliance and light the Wok Burner and Small Burner at maximum setting. Check the pressure and adjust at the regulator if necessary to the setting in the table on the last page or the Data plate. For ULPG Gas adjust at the regulator on the cylinder – Turn regulator adjusting screw clockwise increases pressure whilst anti-clockwise decreases pressure. Refit the test point sealing screw when finished.

Electrical Equipment and Components

Electrical componentry is primarily located below the hob surface. Removal of the hob is straightforward by removing the control knobs, trivets, the burner caps and burner head assemblies and skirts. Using a flat bladed screwdriver remove the five screws, one in each corner of the hotplates left and right spillage bowls and one centrally located at the rear of the centre spillage bowl. Then lift the hob upwards. Replacement is a reversal of the above procedure. Care must be taken to ensure that no damage occurs to the spark ignition leads or the igniters. The electronic ignition pack is easily accessible for service or replacement below the hob centrally at the rear.

ALWAYS ENSURE THAT THE POWER SUPPLY IS DISCONNECTED BEFORE SERVICING APPLIANCE

Gas Controls And Gas Manifold

Removal of the gas manifold is accomplished by removing the control knobs, the trivets, the burner caps and burner head assemblies and skirts. Using a flat bladed screwdriver remove the five screws, one in each corner of the hotplates left and right spillage bowls and one centrally located at the rear of the centre spillage bowl. Care must be taken to ensure that no damage occurs to the spark ignition leads, igniters or thermocouples (if fitted). Disconnect all ancillary gas piping. Remove the two securing screws from the positioning brackets at the front and also the securing bracket near the gas inlet point to the burner compartment. The gas manifold may then be extracted. Replacement is a reversal of the above procedure.

ALWAYS ENSURE THAT THE GAS CONNECTION IS DISCONNECTED BEFORE SERVICING APPLIANCE

Conversion

If the appliance is to be used with another gas type, either ULPG Gas or Natural Gas, it must be converted by an Authorised Person. Contact Eurolinx Pty Ltd or their unathorized agent for details. For Natural and ULPG Gas Injector Sizes and Mj/H refer to tables on pages 21 & 22. The table on page 22 shows the appropriate injector sizes for either ULPG Gas or Natural Gas.

NOTE

After conversion check the GAS PRESSURE and IGNITER OPERATION for the burners. If the hotplate cooker cannot be adjusted to perform correctly, or if there is excessive flame discolouration, yellow tipping or excessive noise contact ILVE or their authorised agent for advice. It is also recommended that this appliance be serviced at 12 months minimum intervals or sooner as required. Please also ensure that the duplicate data plate supplied be attached to the appliance or in an accessible place such as a cupboard for future reference.

IMPORTANT: Verify periodically the gas connection pipe and replace it as soon as any irregularity is present.

IMPORTANT: Correct positioning of the brass flame distributor is very important. For this purpose, ensure that the flame distributor tooth coincides with the notch on the aluminum base. To keep the flame distributor covers new, you are advised to remove them before lighting the flame.

The Manufacturer declines any liability in case of direct or indirect damages caused by an incorrect installation, changes, poor servicing or incorrect use.

Eurolinx Pty Ltd

48-50 Moore Street Leichhardt NSW 2040

T: 1300 MY ILVE (694 563)

F: 02 8569 4699

ACN: 001 473 347

SERVICE

All warranty service calls must be booked though ILVE's Customer Care Department at customercare@eurolinx.com.au or 1 300 85 64 11 option 1 . For out-of-warranty service you can find authorised service agents in your area at <https://support.eurolinx.com.au/#/map/retailers> or by contacting us via email at: customercare@eurolinx.com.au

CLEANING, CARE & MAINTENANCE

Cooktops

Clean the stainless steel cooktop surface after each use with a clean cloth and normal detergent. Make sure the detergent does not contain chloride or any chloride compound. For persistent stains use warm vinegar or a non-abrasive cleaner. To make cleaning easier always wipe spills when they occur, do not leave them to dry as this makes cleaning harder.

Trivets

Trivets should only be cleaned once they have cooled, to stop crazing from occurring. To clean trivets, wash in sink with warm soapy water then dry immediately using a clean dry cloth. Do not use anything too abrasive such as a chrome detergent as this may cause damage. The alkalinity of dishwashing detergents could damage the trivets. If you choose to wash the trivets in the dishwasher we recommend you use a hot rinse mode with no detergent. Enameled trivets may over a period of time discolour, this is due to exposure to a naked flame which may burn the enamel edge off the tips of trivets. This will not affect the performance of the cooktop. To remove surface staining use any cooking oil and a fine brush or scourer, lightly oiling trivets will also help in keeping their new appearance.

Burner caps

The burner caps sit on the brass burners. To clean, remove and wash in warm water. Burner caps should not be put into cold water immediately after use, as crazing will occur, always allow caps to cool before cleaning. ILVE recommend removing the burner caps when cooking as they are only cosmetic.

Brass burners

The brass burners will tarnish to a brown colour with use. To clean simply soak in white vinegar for 20 minutes to remove food splatter.

Aluminium skirts

The aluminium skirt from the base of the burner may be washed in warm soapy water using a gentle scouring pad to remove any burnt on food splatter. A commercial product such as Autosol, which is designed for cleaning aluminium, can be used following makers' instructions. Do not put skirts in the dishwasher as this will cause the aluminium to discolour. ILVE recommend burner skirt covers to help protect the Aluminium Skirts (available at all ILVE Showrooms or shop.ilve.com.au).

Stainless steel

Stainless steel can be cleaned using a range of commercial products and stainless steel cleaners. Follow makers' instructions, taking care when cleaning around the graphics. When cleaning, be sure to follow the grain of the stainless steel as much as possible. Never use abrasive products on the stainless steel as it will scratch the stainless steel. Take care not to drop substances containing sugar on the hob, if this does happen clean with warm water immediately.

Oven light replacement

Replacement globes are available from the Ilve service department. When changing over the lamp always switch off the power first. Unscrew the glass cover over the globe by twisting it anti-clockwise. If glass cover is hard to unscrew, heat oven slightly, as this will heat any fat that might be congealed around the glass, and unscrew using a cloth. Remove existing globe and fit new 'edison screw' bulb, refit the glass cover and switch on the power.

NOTE: The light may be difficult to remove over time. Try using Multi-Grips being sure NOT to break the bulb and/or glass.

Rangehoods

Rangehood filters need to be washed regularly by using warm soapy water and dried using a soft dry cloth. There are various commercial products available which also may be used. Follow manufacturers' directions for use. Cleaning filters in the dishwasher: The heavy alkalinity of dish washing detergents could damage filters. If you choose to wash the filters in the dishwasher we recommend you use a hot rinse mode with no detergent.

Recommended cleaning products

Burner Skirts and Brass Burners:

- Autosol metal polish, available at automotive shops
- Autosol shine, available at Car auto retailers

Solid Plates:

- Hillmark solid hotplate protector, available at supermarkets

Ceramic Plates:

- Hillmark Cera-clean, available at electrical stores
- Hillmark CeraPol, available at Supermarkets

Take care not to drop substances containing sugar on the hob, if this does happen clean with warm water immediately

Enamel Interior of Ovens:

- Non-Caustic oven cleaner. Spray the cleaner onto a damp cloth rather than spraying directly into oven to prevent the spray getting onto the catalytic liners, which can cause damage.

Stainless Steel:

- Cut back stainless steel solution for initial use only, available from ILVE Showrooms or shop.ilve.com.au
- 3M Stainless Steel Cleaner and Polisher, available at supermarkets
- Gumption, available at supermarkets
- Watered down Windex (1/3 Windex to 2/3 water) available at supermarkets

IMPORTANT: Always use non-caustic cleaners on Ilve products The above products are recommendations only. ILVE will not be held responsible for any non ILVE product.

NOTE: ILVE sells a select range of cleaning products through our showrooms and on our **NEW** online shop.



ILVE DVD available for purchase at shop.ilve.com.au

ILVE RECIPES



Tepanyaki



Australian Breakfast



Fettuccine with
Chilli & Garlic



Marinated Seafood
Skewers



Steamed Trout with
Dill & Lemon



More recipes are available on
the ILVE operating Instructions DVD
available for purchase at shop.ilve.com.au



Serves 2



Preparation time:
10 minutes



Cooking time:
10 minutes

Ingredients:

- 2 piece of trimmed steak
(the cut of meat is up to you)
- 2 pieces of salmon steaks
(or any other fish steak)
- ½ a capsicum
- 4 mushrooms
- ½ a bunch of rosemary leaves
- ½ an onion chopped
- 1 bunch of shallot tails
- 1 garlic clove
- Extra virgin olive oil
- Salt and pepper

- 1 Cut and trim vegetables place in deep bowl and mix in rosemary leaves garlic and extra virgin olive oil and mix well.
- 2 Pre heat teppanyaki plate on high for 10 minutes.
- 3 Brush steak and chicken with extra virgin olive oil and season to taste with salt and pepper then add to the teppanyaki plate.
- 4 Once the steak and salmon require turning add the vegetables to the teppanyaki plate and work the vegetables until meat has finished cooking then serve.

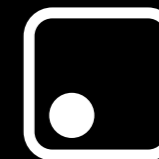

TEPANYAKI





AUSTRALIAN BREAKFAST



Serves 2



Preparation time
10 minutes



Cooking time
10 minutes

Ingredients:

4 eggs
4 sausages
6 rashers or bacon
2 large mushrooms sliced
2 tomatoes halved

1

Heat teppanyaki plate up for 10 minutes then brush plate with extra virgin olive oil.

2

Place sausages on teppanyaki plate and cook for 5 minutes turning as needed.

3

Add bacon, mushroom, tomatoes and cook for a further 5 minutes.

4

Add eggs onto the plate and remove all food from the teppanyaki plate when the eggs have cooked.

ILVE COOKING TIP

To avoid splatter and trap heat, use ILVE's teppanyaki dome cover accessory.



Serves 4



Preparation time
10 minutes



Cooking time
10 minutes

Ingredients:

500g fettuccine
Salt
1 chilli sliced thinly
2 cloves garlic crushed
3 tablespoons olive oil
Grated parmesan

1

Bring large saucepan of salted water to the boil.

2

Cook fettuccine, uncovered, until just tender then drain.

3

Heat oil in a large frying pan, add chilli and garlic, frying gently for 2 minutes.

4

Add drained pasta to chilli and garlic mix, toss gently to combine. Divide pasta among serving bowls and top with grated parmesan.

ILVE COOKING TIP

For variations of this dish add seafood, meats, cream or tomato sauces according to your taste.

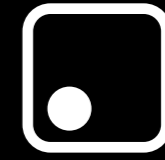

FETTUCCHINE WITH CHILLI & GARLIC





MARINATED SEAFOOD SKEWERS



Serves 4



Preparation time
20 minutes



Cooking time
5 minutes

Ingredients:

1kg seafood, salmon,
green prawns and octopus
½ cup (125ml) olive oil
Juice 1 lemon
2 cloves garlic, crushed
1 tablespoon parsley or
dill, chopped
Freshly ground pepper, to taste
Bamboo skewers, soaked
in water

1
Cut salmon into cubes, peel prawns
and cut tentacles off octopus,
leaving on tails.

2
Mix together oil, lemon, parsley or
dill and pepper to taste in a bowl,
making marinade.

3
Add seafood and marinate for about
15 minutes.

4
Heat teppanyaki plate or grill
plate to hot.

5
Place skewers on heated plate and
cook for approximately 5 minutes,
turning frequently.

6
Serve immediately.

ILVE COOKING TIP

Do not overcook seafood,
generally once it has lost
its opaque appearance the
seafood is ready.



Serves 6-8



Preparation time
10 minutes



Cooking time
15 minutes

Ingredients:

1 500g trout, cleaned
and scaled
1-2 cups (500mL) fish stock
or water
Sprigs of dill
1 lemon, sliced
1 spanish onion, sliced

1
Place trout, dill, lemon slices
and spanish onion slices onto a
perforated tray into fish kettle.

2
Carefully pour in 1-2 cups of water
or stock in fish kettle and lower tray
with trout carefully into fish kettle,
cover with lid.

3
Steam the fish with a gentle simmer
for approximately 10-15 minutes.
Test fish after 10 minutes by using a
fork to flake the thickest part of the
trout. It is ready when it flakes easily.

ILVE COOKING TIP

Check fish with point of knife
by lifting the flesh, fish will be
ready when the opaque
appearance of the flesh is gone.

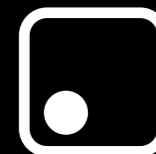

STEAMED TROUT WITH DILL & LEMON



Eurolinx Pty Limited A.B.N. 50 001 473 347 trading as ILVE ("ILVE")

Office:
48-50 Moore Street, Leichhardt N.S.W 2040
Post:
Locked Bag 3000, Annandale, N.S.W 2038
P: 1300 856 411

WARRANTY REGISTRATION

Your ongoing satisfaction with your ILVE product is important to us. We ask that you complete the enclosed Warranty Registration Card and return it to us so that we have a record of the ILVE product purchased by you. Alternatively, you can now register your warranty online at <http://support.eurolinx.com.au/>

PRIVACY

ILVE respects your privacy and is committed to handling your personal information in accordance with the National Privacy Principles and the Privacy Act 1988 (Cth). A copy of the ILVE Privacy Policy is available at www.ilve.com.au. ILVE will not disclose any personal information set out in the Warranty Registration Card ("Personal Information") without your consent unless required by:

1. law;
2. any ILVE related company;
3. any service provider which provide services to ILVE or assist ILVE in providing services (including repair and warranty services) to customers. Our purpose in collecting the Personal Information is to keep a record of the ILVE product purchased by you, in order to provide a better warranty service to you in the unlikely event that there is a problem with your ILVE product. ILVE may contact you at any one or more of the addresses, email addresses or telephone numbers set out in the Warranty Registration Card. Please contact ILVE on 1300 694 583 should you not wish to be contacted by ILVE.

WARRANTY

1. Warranty
 ILVE warrants that each ILVE product will remain, for a period of twenty four (24) months computed from the date of purchase of the ILVE product, free from defects arising in the manufacture of the ILVE product ("Warranty"). Except for consumer guarantees set out in the Competition and Consumer Act 2010 (Cth) ("Act"), ILVE does not make any further warranties or representations in relation to ILVE products.

2. What is not Covered by the Warranty.

The Warranty does not apply if an ILVE product is defective by a factor other than a defect arising in the manufacture of the ILVE product, including but not limited to:

- (a) damage through misuse (including failure to maintain, service or use with proper care), neglect, accident or ordinary wear and tear (including deterioration of parts and accessories and glass breakage);
- (b) use for purpose for which the ILVE product was not sold or designed;
- (c) use or installation which is not in accordance with any specified instructions for use or installation;
- (d) use or operation after a defect has occurred or been discovered;
- (e) damage through freight, transportation or handling in transit (other than when ILVE is responsible);
- (f) damage through exposure to chemicals, dusts, residues, excessive voltage, heat, atmospheric conditions or other forces or environmental factors outside the control of ILVE;
- (g) repair, modification or tampering by the purchaser or any person other than ILVE, an employee of ILVE or an authorised ILVE service contractor*;
- (h) use of parts, components or accessories which have not been supplied or specifically approved by ILVE.
- (i) damage to surface coatings caused by cleaning or maintenance using products not recommended in the ILVE product handbook provided to the purchaser upon purchase of the ILVE product;
- (j) damage to the base of an electric oven due to items having been placed on the base of the oven cavity or covering the base, such as aluminium foil (this impedes the transfer of heat from the element to the oven cavity and can result in irreparable damage); or
- (k) damages, dents or other cosmetic imperfections not affecting the performance of the ILVE in respect of an ILVE product purchased as a "factory second" or from display

The Warranty does not extend to light globes used in ILVE products.

3. Domestic Use

Each ILVE product is made for domestic use. This Warranty may not extend to ILVE products used for commercial purposes.

4. Time for Claim under the Warranty

You must make any claim under this Warranty within twenty eight (28) days after the occurrence of an event which gives rise to a claim pursuant to the Warranty, by booking a service call on the telephone number below.

Continued over...

5. Proof of Purchase

Customers must retain proof of purchase in order to be eligible to make a warranty claim in respect of an ILVE product.

6. Claiming under the Warranty

Customers will bear the cost of claiming under this Warranty unless ILVE determines the expenses are reasonable, in which case the customer must claim those expenses by providing written evidence of each expense to ILVE at the address on the Warranty Registration Card.

7. Statutory Rights

- (a) These terms and conditions do not affect your statutory rights.
- (b) The limitations on the Warranty set out in this document do not exclude or limit the application of the consumer guarantees set out in the Act or any other equivalent or corresponding legislation in the relevant jurisdiction where to do so would:
 - (i) contravene the law of the relevant jurisdiction; or
 - (ii) cause any part of the Warranty to be void.
- (c) ILVE excludes indirect or consequential loss of any kind (including, without limitation, loss of use of the ILVE product) and (other than expressly provided for in these terms and conditions) subject to all terms, conditions and warranties implied by custom, the general law, the Act or other statute.
- (d) The liability of ILVE to you for a breach of any express or non-excludable implied term, condition or warranty is limited at the option of ILVE to:

- (i) replacing or repairing the defective part of the ILVE product;
 - (ii) paying the cost of replacing or repairing the defective part of the ILVE product;
 - (iii) replacing the ILVE product; or
 - (iv) paying the cost of replacing the ILVE product.
- (e) Our goods come with guarantees that cannot be excluded under the Australian Consumer Law. You are entitled to a replacement or refund for a major failure and for compensation for any other reasonably foreseeable loss or damage. You are also entitled to have the goods repaired or replaced if the goods fail to be of acceptable quality and the failure does not amount to a major failure.

8. Defects

Any part of an ILVE product deemed to be defective and replaced by ILVE is the property of ILVE. ILVE reserves the right to inspect and test ILVE products in order to determine the extent of any defect and the validity of a claim under the Warranty.

***For your closest ILVE authorised service agent go to**

<https://support.eurolinx.com.au/#/map/retailers>

All warranty service calls must be booked through ILVE's Customer Care Centre on customercare@eurolinx.com.au or

1300 85 64 11 option 1

01012018

Warranty Card tear off

WARRANTY REGISTRATION CARD
 01032017

Please complete and send to ILVE at: REPLY PAID 83617
 LEICHHARDT NSW 2040

Last Name:		First Name:	
Address:			
State:	Postcode:	Email:	
Home Phone:		Mobile:	
Purchase Date: / /		(Please attach proof of purchase to validate warranty)	



MODEL NUMBER	SERIAL NUMBER (if you cannot locate the serial number please call ILVE on 1300 85 64 11)
1	
2	
3	
4	

PROBLEM	ANSWER
COOKTOPS	
My burners will not ignite	<ul style="list-style-type: none"> • Check to see if the brass burners are placed correctly into the aluminium base. This is very important as it will ensure the flame holes line up with the ignition post and spark. It will also ensure correct combustion when alight. • Does your ILVE cooktop have flame failure devices fitted? Ensure burners are located correctly as above. When burner is lit, ensure knob is firmly depressed for 5 to 10 seconds. • If there is a saucepan (or similar) on the burner, remove it before igniting • Check to see that the electric igniter is lined up with the solid part of the burner
Does your ILVE cooktop have flame failure devices fitted?	Ensure burners are located correctly as above. When burner is lit, ensure knob is firmly depressed for 5 to 10 seconds. If new, ensure knobs are firmly fitted, check by pushing knobs down firmly with the palm of your hand.
My ignition continually sparks	This may be due to a liquid spill over, which can cause moisture to enter into ignition micro switches under knobs. Spraying liquid type cleaners can also create a problem. If this does occur, the cooktop should be turned off at power point and left to dry out. Removing all knobs and using a hair dryer on the control panel, will assist the drying out process.
All the igniters spark at the same time when lighting	This is normal and how they are designed to operate.
The knob is loose on shaft	Knob retaining spring clip has come out. This does not require a service technician and can be replaced by the customer. Please contact your ILVE state office, who will arrange for a clip to be sent to you.
The burner is extinguished when the cupboards or drawers are opened or shut	In this case, the underside of the cooktop needs to be totally sealed off from the surrounding cupboards or drawers.
The flame tips are yellow causing the pots to blacken on the underside	The gas type may be incorrect contact your installer and have him check the gas type and the injector size and or the aeration needs adjusting see pages 40-41
The low flame is still too high	The low flame bypass screw needs to be adjusted contact your installer and have him adjust the low flame setting as per the specification on page 41.

iWarranty
REGISTER YOUR WARRANTY ONLINE NOW

GO TO: <https://support.eurolinx.com.au/#/form/warrantyregistration>

You can now find us on:

-  facebook.com/ILVEappliances
-  twitter.com/ILVE_appliances
-  youtube.com/ILVEappliances
-  livewithilve.com

01012018

Australia National Telephone Number 1300 MYILVE (694 583) New Zealand Telephone Number 0508 458 369
iLVE showrooms are open Tuesday - Friday: 9am-5pm and Saturdays 10am-4pm. Closed on Monday & Sunday

ilve.com.au

NSW & ACT (Head Office)

48-50 Moore Street
Leichhardt
F 02 8569 4699

VIC & SA

1211 Toorak Road
Camberwell
F 03 9809 2155

QLD

1/42 Cavendish Road
Coorparoo
F 07 3397 0850

WA & NT

Unit 10/55 Howe Street
Osborne Park
F 08 9201 9188

TAS (Crisp Ikin)

3 Pear Avenue
Derwent Park, 7009
P 03 6272 7386

New Zealand

PO Box 11.160
Sockburn Christchurch
F 03 344 5906

