

5KHM926



KitchenAid

TABLE OF CONTENTS

HAND MIXER SAFETY	2
Important Safeguards.....	3
Electrical Requirements.....	3
PARTS AND FEATURES	4
ACCESSORY GUIDE	5
SETTING UP YOUR HAND MIXER	
Attaching the Accessories.....	5
Removing the Accessories.....	6
USING YOUR HAND MIXER	
Operating the Speed Control.....	7
Speed Control Guide	8
CARE AND CLEANING	
Cleaning the Hand Mixer body.....	9
Cleaning the accessories.....	10
Cleaning the storage bag	10
TROUBLESHOOTING	11

HAND MIXER SAFETY

Your safety and the safety of others are very important.

We have provided many important safety messages in this manual and on your appliance. Always read and obey all safety messages.



This is the safety alert symbol.

This symbol alerts you to potential hazards that can kill or hurt you and others.

All safety messages will follow the safety alert symbol and either the word “DANGER” or “WARNING.” These words mean:

 **DANGER**

You can be killed or seriously injured if you don't immediately follow instructions.

 **WARNING**

You can be killed or seriously injured if you don't follow instructions.

All safety messages will tell you what the potential hazard is, tell you how to reduce the chance of injury, and tell you what can happen if the instructions are not followed.

IMPORTANT SAFEGUARDS

When using electrical appliances, basic safety precautions should always be followed, including the following:

1. Read all instructions.
2. To protect against risk of electrical shock, do not put Hand Mixer in water or other liquid.
3. Unplug Hand Mixer from the outlet when not in use, before putting on or taking off parts, and before cleaning.
4. Avoid contacting moving parts. Keep hands, hair, clothing, as well as spatulas and other utensils away from all accessories during operation to reduce the risk of injury to persons and/or damage to the Hand Mixer.
5. Do not operate the Hand Mixer with a damaged cord or plug, or after the Hand Mixer malfunctions, or is dropped or damaged in any manner. Return the Hand Mixer to the nearest Authorized Service Center for examination, repair, or electrical or mechanical adjustment.
6. The use of attachments not recommended or sold by KitchenAid may cause fire, electric shock, or injury.
7. Do not use the Hand Mixer outdoors.
8. Do not let cord hang over edge of table or counter.
9. Do not let cord contact hot surface, including the stove.
10. Remove any accessories from Hand Mixer before washing.
11. This appliance is not intended for use by persons (including children) with reduced physical, sensory or mental capabilities, or lack of experience and knowledge, unless they have been given supervision or instruction concerning use of the appliance by a person responsible for their safety.
12. Children should be supervised to ensure that they do not play with the appliance.
13. Switch off the appliance and disconnect from supply before changing accessories or approaching parts that move in use.

SAVE THESE INSTRUCTIONS

Electrical requirements

Volts: 220-240 Volts
Frequency: 50/60 Hz
Wattage: 85 W

PARTS AND FEATURES

Hand Mixer parts and accessories

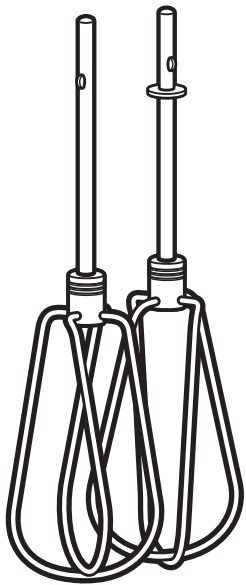
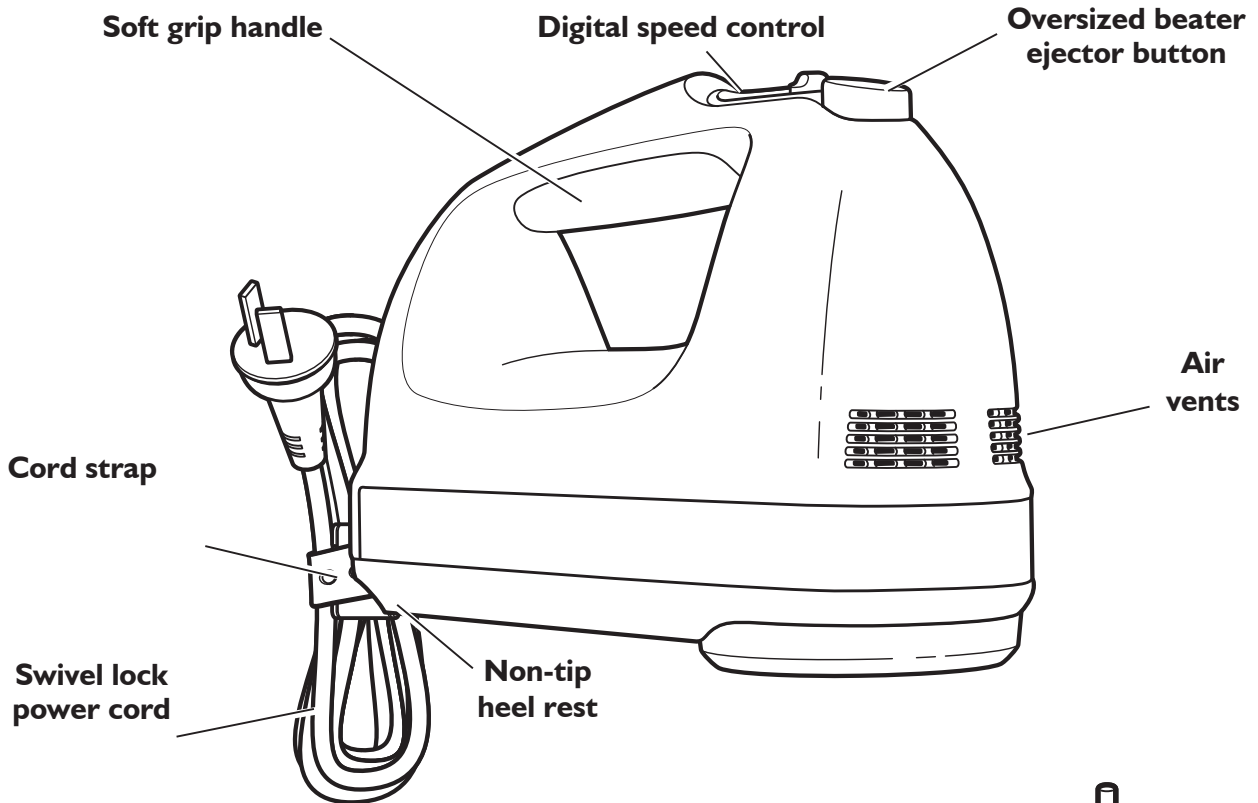

**Turbo Beater II
accessory**

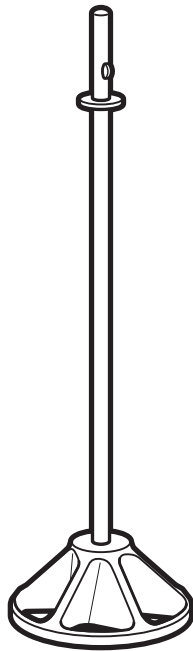

**Liquid blender
rod accessory**

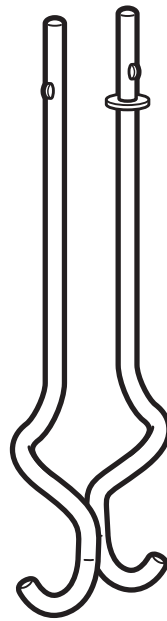

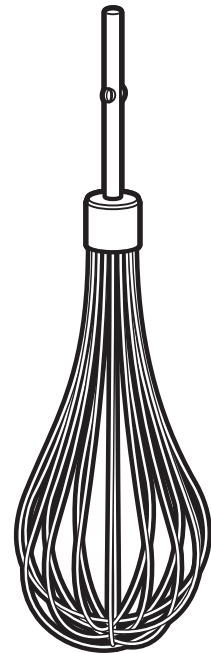

Dough hooks accessory



**16-Tine pro whisk
accessory**

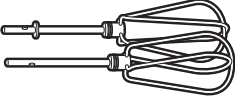
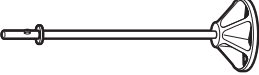

Storage bag

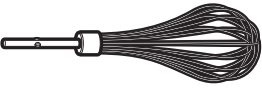
Accessory	Uses
<p>Turbo Beater II</p> 	<p>cookie dough cake batter</p>
<p>Liquid blender rod</p> 	<p>smoothies, diet drink mixes, chocolate milk, iced tea, milkshakes, soups, sauces</p>
<p>Dough hooks</p> 	<p>yeast bread doughs</p>
<p>16-Tine pro whisk</p> 	<p>whipped cream, whipped egg whites, sauces, puddings</p>

SETTING UP YOUR HAND MIXER

Attaching the accessories

! WARNING

Injury Hazard

Unplug mixer before touching beaters.

Failure to do so can result in broken bones, cuts, or bruises.

IMPORTANT: Be sure to read and follow the specific instructions in this manual for proper use of the Hand Mixer.

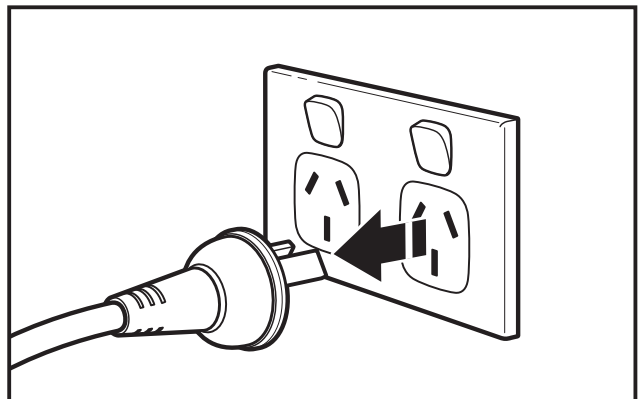

I Unplug the Hand Mixer from the electrical outlet.

SETTING UP YOUR HAND MIXER

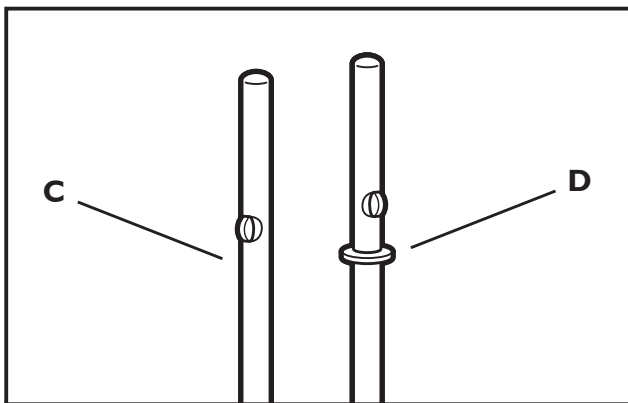

Paired accessories (beaters, optional dough hooks) include one accessory with a collar (D), and one without (C). Single accessories come with a collar (D) (liquid blending rod) or without (C) (whisk).

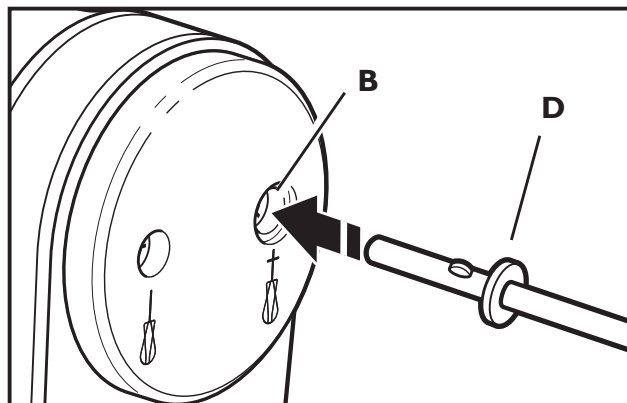

2 Insert the accessory shaft with the collar (D) into the larger opening (B) of the hand mixer. Align the flanges on the shaft with the slots in the opening. Push to lock into place.

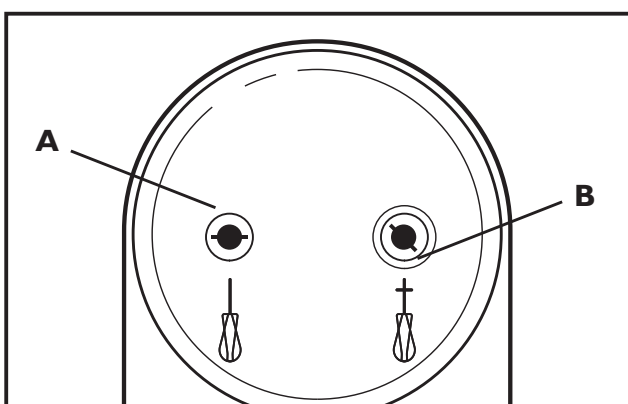

3 Insert the accessory without a collar (C) into the smaller opening (A). Align and push to lock into place.

NOTE: An accessory shaft without a collar may be used in either opening (A or B). Those with a collar may only be used in the larger opening (B).

Removing the accessories

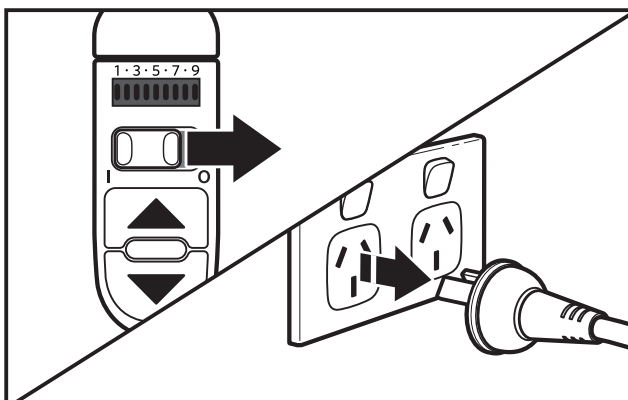

1 If the Hand Mixer is running, stop the Hand Mixer by sliding the Power switch to the "O" (Off) position. Then, unplug the Hand Mixer from the electrical outlet.

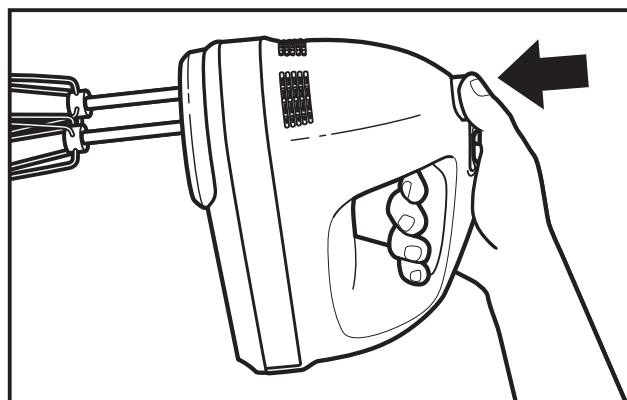

2 Press the Ejector Button to release the accessories from the Hand Mixer, then remove them.

Operating the Speed Control

This KitchenAid Hand Mixer will beat faster and more thoroughly than most other electric hand mixers. Therefore, the beating time in most recipes must be adjusted to avoid over beating. Beating time is faster due to larger beater sizes.

To help determine the ideal beating time, observe the batter or dough and beat only until it has the desired appearance described in your recipe, such as “smooth and creamy”. To select the best beating speeds, use the “Speed control guide” section.

! WARNING

Injury Hazard

Unplug mixer before touching beaters.

Failure to do so can result in broken bones, cuts, or bruises.

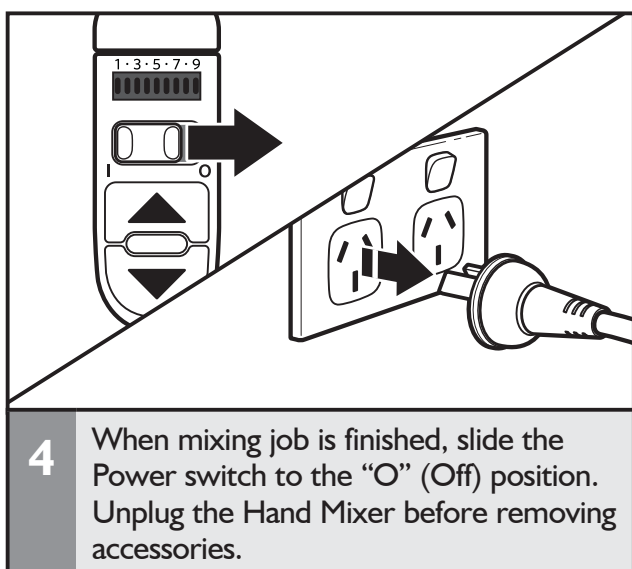
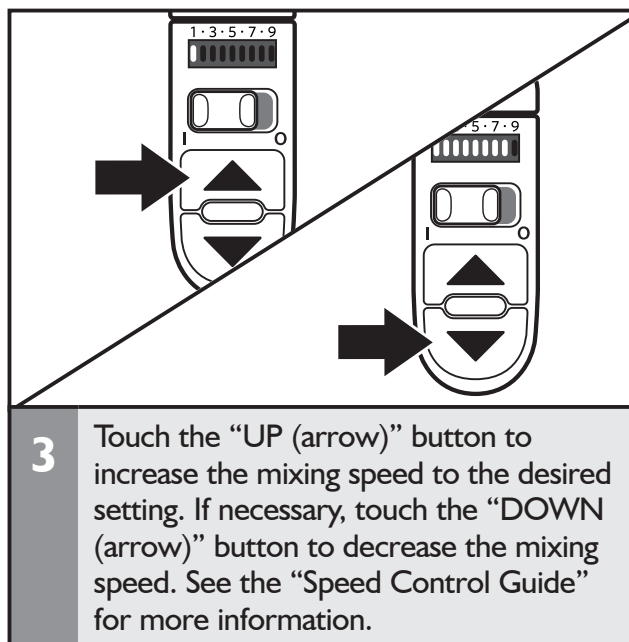
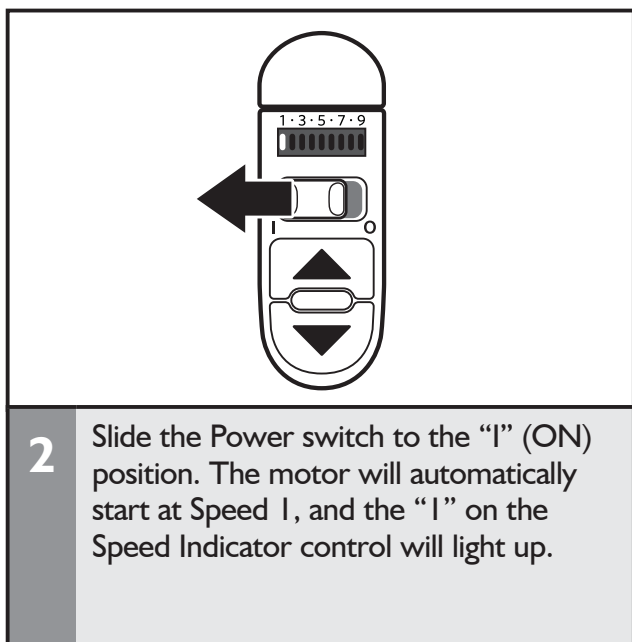
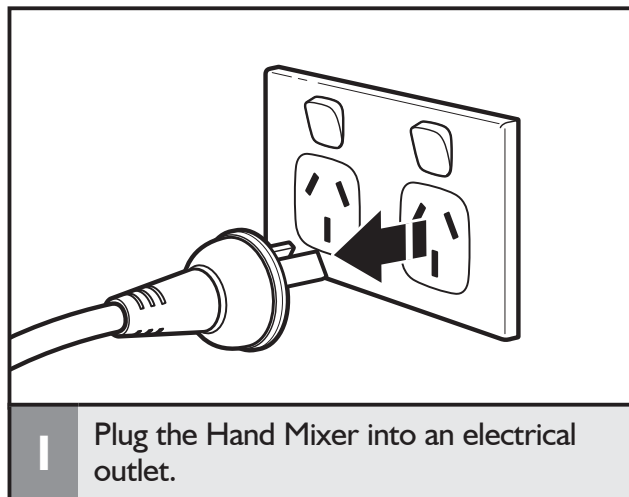

NOTE: The Hand Mixer automatically starts at Speed 1 every time it is turned on, regardless of the Speed setting at the time the mixer is shut off.

Speed Control Guide

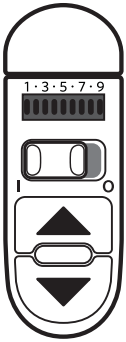

The 9-Speed Hand Mixer always starts on the lowest speed (Speed 1). Move to higher speeds as needed, the speed setting indicator control will light up with the corresponding number for each speed.

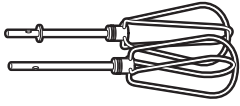
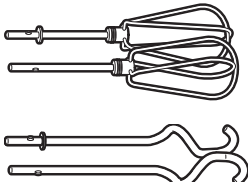
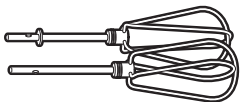
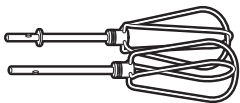
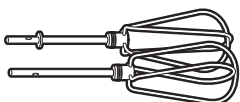
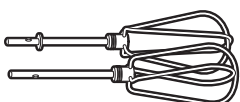
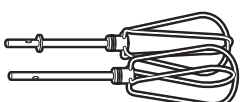
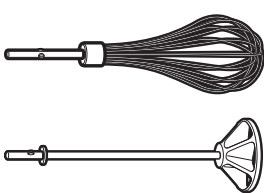
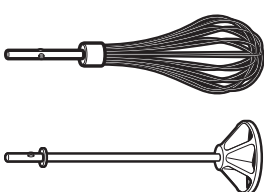
Speed	Attachment	Description
1		For slow stirring, combining, and starting all mixing procedures. Use this speed to stir in nuts, chocolate chips, shredded cheese, onions, olives, and other chunky ingredients.
2		Mix flour and other dry ingredients with liquids or other moist mixtures. Knead yeast dough (bread, pizza dough) with the dough hooks.
3		Mix runny batters, such as pancake or waffle batter.
4		Combine heavy mixtures, such as cookie or biscuit dough.
5		Mix thick dough, such as muffin or cake batter. Mash potatoes or squash.
6		Blend butter and sugar. Mix frostings.
7		Finish mixing cake and other batters.
8		Whip cream and mousse mixtures.
9		Beat egg white and meringue mixtures.

NOTE: Beater accessories are not designed for mixing and kneading bread dough. Special dough hook attachments are available. See “Accessories” section for details and ordering information.

Cleaning the Hand Mixer body

⚠️ WARNING



Electrical Shock Hazard

Do not put in water.

Doing so can result in death or electrical shock.

⚠️ WARNING

Injury Hazard

Unplug mixer before touching beaters.

Failure to do so can result in broken bones, cuts, or bruises.

NOTE: Do not immerse Hand Mixer in water.

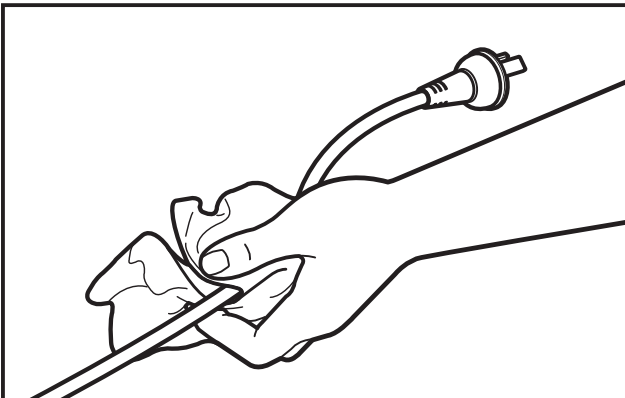

1 Always unplug Hand Mixer before cleaning. Wipe power cord and cord strap with a warm, soapy cloth; then wipe clean with a damp cloth. Dry with a soft cloth.

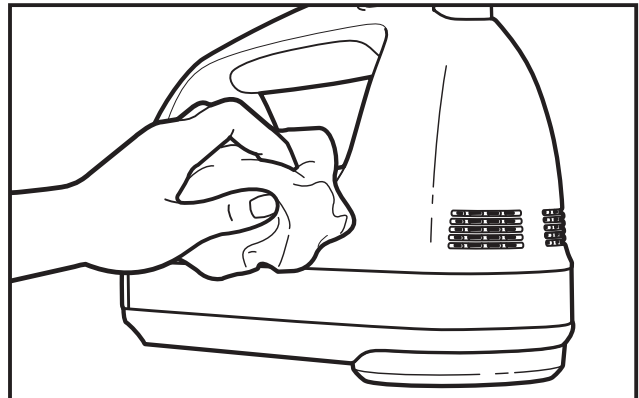

2 Wipe Hand Mixer with a warm, soapy cloth; then wipe clean with a damp cloth. Dry with a soft cloth.

Cleaning the accessories

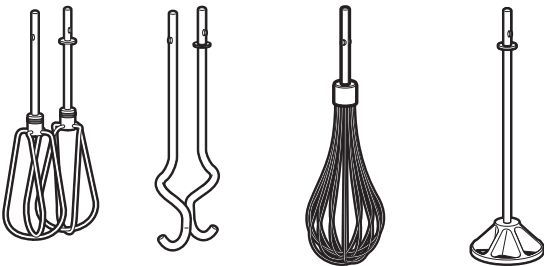

Always remove beaters from Hand Mixer before cleaning. Wash in dishwasher, or by hand in warm, soapy water. Rinse and wipe dry.

Cleaning the storage bag



Wipe storage bag with a warm, soapy cloth; then wipe clean with a damp cloth. Dry with a soft cloth.

If Hand Mixer malfunctions or fails to operate

First try the solutions suggested here and possibly avoid the cost of service.

1. Is the Hand Mixer plugged in?
2. Is the fuse in the circuit to the Hand Mixer in working order? If you have a circuit breaker box, make sure the circuit is closed.
3. Try unplugging the Hand Mixer, then plug it back in.

If the problem cannot be fixed with the steps provided in this section, then contact KitchenAid or an Authorized Service Center.



KitchenAid

© 2013. All rights reserved.

