

Owner's Manual

CRAFTSMAN®
6.0 HORSEPOWER
21" MULTI-CUT
POWER PROPELLED
ROTARY LAWN MOWER

Model No.
917.377160

- **Safety**
- **Assembly**
- **Operation**
- **Maintenance**
- **Español**
- **Repair Parts**

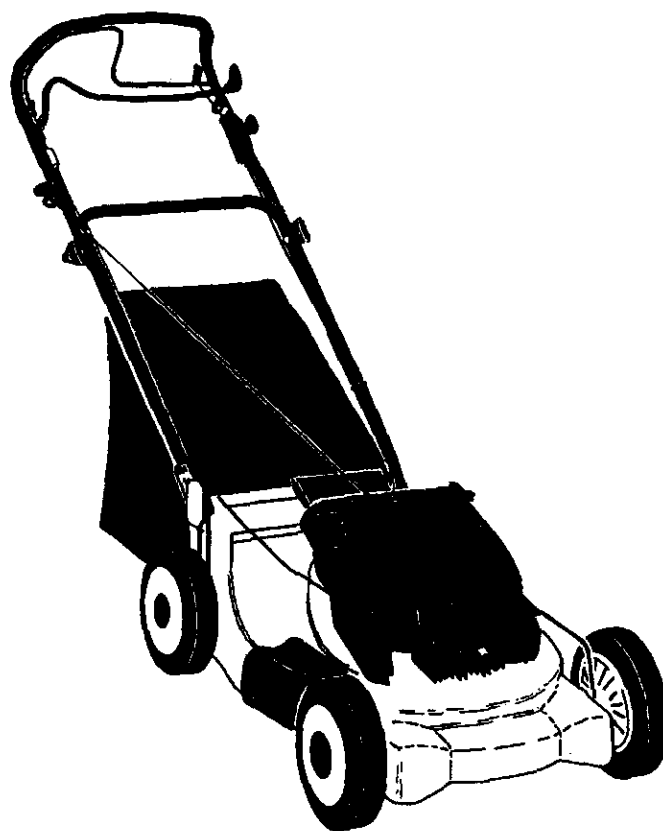

CAUTION:

Read and follow all
Safety Rules and Instructions
before operating this equipment

Sears, Roebuck and Co., Hoffman Estates, IL 60179
Visit our Craftsman website: www.sears.com/craftsman

TABLE OF CONTENTS

Warranty	2	Product Specifications	12
Safety Rules	2	Service and Adjustments	15
Assembly	4	Storage	16
Operation	6	Troubleshooting	17
Maintenance Schedule	11	Repair Parts	38
Maintenance	11	Parts Ordering	Back Cover

WARRANTY

LIMITED TWO YEAR WARRANTY ON CRAFTSMAN POWER MOWER

For two years from date of purchase, when this Craftsman Lawn Mower is maintained, lubricated, and tuned up according to the operating and maintenance instructions in the owner's manual, Sears will repair free of charge any defect in material or workmanship. If this Craftsman Lawn Mower is used for commercial or rental purposes, this warranty applies for only 90 days from the date of purchase.

This Warranty does not cover:

- Expendable items which become worn during normal use, such as rotary mower blades, blade adapters, belts, air cleaners and spark plug.
- Repairs necessary because of operator abuse or negligence, including bent crankshafts and the failure to maintain the equipment according to the instructions contained in the owner's manual.

Warranty service is available by returning the Craftsman power mower to the nearest Sears Service Center/Department in the United States. This warranty applies only while this product is in use in the United States.

This Warranty gives you specific legal rights, and you may also have other rights which vary from state to state.

SEARS, ROEBUCK AND CO., D/817 WA, HOFFMAN ESTATES, ILLINOIS 60179

SAFETY RULES

Safety standards require operator presence controls to minimize the risk of injury. Your unit is equipped with such controls. Do not attempt to defeat the function of the operator presence controls under any circumstances.

TRAINING:

- Read this operator's manual carefully. Become familiar with the controls and know how to operate your mower properly. Learn how to quickly stop mower.
- Do not allow children to use your mower. Never allow adults to use mower without proper instructions.
- Keep the area of operation clear of all persons, especially small children and pets.
- Use mower only as the manufacturer intended and as described in this manual.
- Do not operate mower if it has been dropped or damaged in any manner.

Always have damage repaired before using your mower.

- Do not use accessory attachments that are not recommended by the manufacturer. Use of such attachments may be hazardous.
- The blade turns when the engine is running.

PREPARATION:

- Always thoroughly check the area to be mowed and clear it of all stones, sticks, wires, bones, and other foreign objects. These objects will be thrown by the blade and can cause severe injury.
- Always wear safety glasses or eye shields when starting and while using your mower.
- Dress properly. Do not operate mower when barefoot or wearing open sandals. Wear only solid shoes with good traction when mowing.

- Check fuel tank before starting engine. Do not fill gas tank indoors, when the engine is running or when the engine is hot. Allow the engine to cool for several minutes before filling the gas tank. Clean off any spilled gasoline before starting the engine.
- Always make wheel height adjustments before starting your mower. Never attempt to do this while the engine is running.
- Mow only in daylight or good artificial light.
- Never cut grass by pulling the mower towards you. Mow across the face of slopes, never up and down or you might lose your footing. Do not mow excessively steep slopes. Use caution when operating the mower on uneven terrain or when changing directions - maintain good footing.
- Never operate your mower without proper guards, plates, grass catcher or other safety devices in place.

OPERATION:

- Keep your eyes and mind on your mower and the area being cut. Do not let other interests distract you.
- Do not mow wet or slippery grass. Never run while operating your mower. Always be sure of your footing - keep a firm hold on the handles and walk.
- Do not put hands or feet near or under rotating parts. Keep clear of the discharge opening at all times.
- Always stop the engine whenever you leave or are not using your mower, or before crossing driveways, walks, roads, and any gravel-covered areas.
- Never direct discharge of material toward bystanders nor allow anyone near the mower while you are operating it.
- Before cleaning, inspecting, or repairing your mower, stop the engine and make absolutely sure the blade and all moving parts have stopped. Then disconnect the spark plug wire and keep it away from the spark plug to prevent accidental starting.
- Do not continue to run your mower if you hit a foreign object. Follow the procedure outlined above, then repair any damage before restarting and operating your mower.
- Do not change the governor settings or overspeed the engine. Engine damage or personal injury may result.
- Do not operate your mower if it vibrates abnormally. Excessive vibration is an indication of damage; stop the engine, safely check for the cause of vibration and repair as required.
- Do not run the engine indoors. Exhaust fumes are dangerous.

MAINTENANCE AND STORAGE:

- Check the blade and the engine mounting bolts often to be sure they are tightened properly.
- Check all bolts, nuts and screws at frequent intervals for proper tightness to be sure mower is in safe working condition.
- Keep all safety devices in place and working.
- To reduce fire hazard, keep the engine free of grass, leaves or excessive grease and oil.
- Check grass catcher often for deterioration and wear and replace worn bags. Use only replacement bags that are recommended by and comply with specifications of the manufacturer of your mower.
- Always keep a sharp blade on your mower.
- Allow engine to cool before storing in any enclosure.
- Never store mower with fuel in the tank inside a building where fumes may reach an open flame or an ignition source such as a hot water heater, space heater, clothes dryer, etc.

⚠ Look for this symbol to point out important safety precautions. It means **CAUTION!!! BECOME ALERT!!! YOUR SAFETY IS INVOLVED.**





⚠ CAUTION: Always disconnect spark plug wire and place wire where it cannot contact spark plug in order to prevent accidental starting when setting up, transporting, adjusting or making repairs.

⚠ WARNING: The engine exhaust from this product contains chemicals known to the State of California to cause cancer, birth defects, or other reproductive harm.



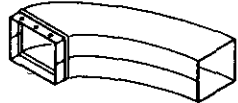

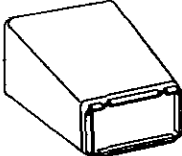
ACCESSORIES

These accessories were available when this lawn mower was produced. They are not shipped with your mower. They are also available at most Sears retail outlets and service centers. Most Sears stores can also order repair parts for you, when you provide the model number of your lawn mower. Some of these accessories may not apply to your lawn mower.

LAWN MOWER PERFORMANCE

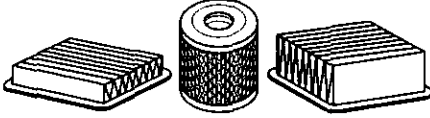
 <p>CLIPPING DEFLECTOR FOR REAR DISCHARGE LAWN MOWERS</p>	 <p>MULCHER KITS</p>	 <p>STABILIZER</p>
 <p>GRASS CATCHERS FOR REAR DISCHARGE LAWN MOWERS</p>	 <p>GRASS CATCHERS FOR SIDE DISCHARGE LAWN MOWERS</p>	 <p>GAS CANS</p>

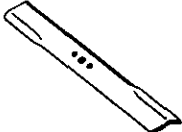
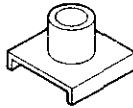
LAWN MOWER MAINTENANCE

 <p>MUFFLERS</p>		 <p>AIR FILTERS</p>		 <p>SPARK PLUGS</p>
 <p>BELTS</p>	 <p>BLADES</p>	 <p>BLADE ADAPTERS</p>	 <p>WHEELS</p>	 <p>ENGINE OIL</p>

ASSEMBLY

Read these instructions and this manual in its entirety before you attempt to assemble or operate your new lawn mower.

IMPORTANT: This lawn mower is shipped WITHOUT OIL OR GASOLINE in the engine.

Your new lawn mower has been assembled at the factory with the exception of those parts left unassembled for shipping purposes. To ensure safe and proper operation of your lawn mower, all parts and hardware you assemble must be tightened securely. Use the correct tools as necessary to ensure proper tightness. All parts such as nuts, washers, bolts, etc., necessary to complete the assembly have been placed in the parts bag.

TO REMOVE LAWN MOWER FROM CARTON

- Remove loose parts included with mower.
- Cut down two end corners of carton and lay end panel down flat.

- Remove all packing materials except padding between upper and lower handle and padding holding operator presence control bar to upper handle.
- Roll lawn mower out of carton and check carton thoroughly for additional loose parts.

HOW TO SET UP YOUR LAWN MOWER

TO UNFOLD HANDLE

IMPORTANT: Unfold handle carefully so as not to pinch or damage control cables.

- Raise lower handle section to operating position and squeeze the bottom ends of lower handle towards each other until the pin in handle can be inserted into one of the three height adjustment holes.
- Remove protective padding, raise upper handle section into place on lower handle and tighten both handle knobs.
- Remove any packing material from around control bar.

- Your handles may be adjusted for your mowing comfort. Refer to Service and Adjustments section of this manual.

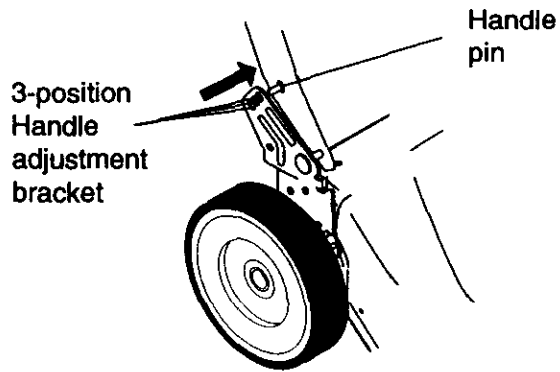
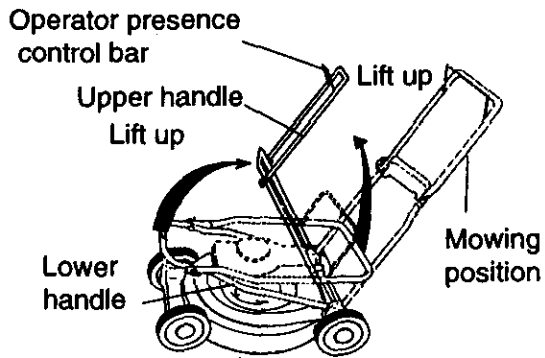

TO INSTALL ATTACHMENTS

Your lawn mower was shipped ready to be used as a mulcher. To convert to bagging or discharging; See OPERATION section of this manual.

OPERATION

KNOW YOUR LAWN MOWER

READ THIS OWNER'S MANUAL AND SAFETY RULES BEFORE OPERATING YOUR LAWN MOWER. Compare the illustrations with your lawn mower to familiarize yourself with the location of various controls and adjustments. Save this manual for future reference.

These symbols may appear on your lawn mower or in literature supplied with the product. Learn and understand their meaning.

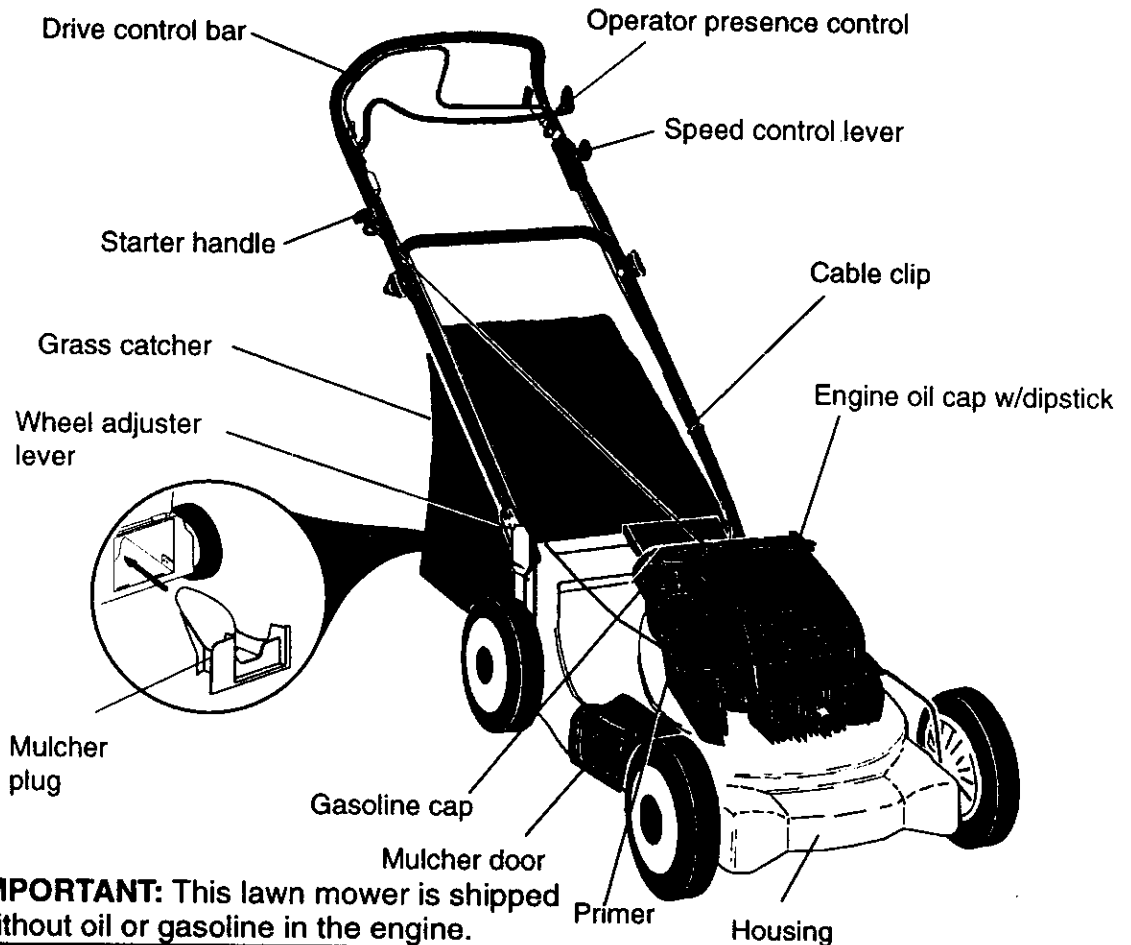
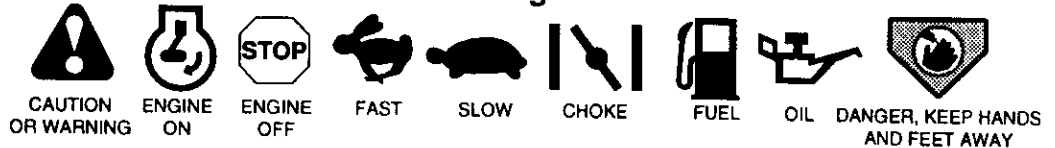

IMPORTANT: This lawn mower is shipped without oil or gasoline in the engine.

MEETS CPSC SAFETY REQUIREMENTS

Sears rotary walk-behind power lawn mowers conform to the safety standards of the American National Standards Institute and the U.S. Consumer Product Safety Commission. The blade turns when the engine is running.

Operator presence control - must be held down to the handle to start the engine. Release to stop the engine.

Primer - pumps additional fuel from the carburetor to the cylinder for use when starting a cold engine.

Starter handle - used for starting the engine.

Drive control bar - used to engage power-propelled forward motion of lawn mower.

Mulcher plug - Located at the rear discharge opening must be removed when converting to bagging operation.

The operation of any lawn mower can result in foreign objects thrown into the eyes, which can result in severe eye damage. Always wear safety glasses or eye shields while operating your lawn mower or performing any adjustments or repairs. We recommend a wide vision safety mask over spectacles or standard safety glasses.

HOW TO USE YOUR LAWN MOWER

ENGINE SPEED

The engine speed was set at the factory for optimum performance. Speed is not adjustable.

ENGINE ZONE CONTROL

CAUTION: Federal regulations require an engine control to be installed on this lawn mower in order to minimize the risk of blade contact injury. Do not under any circumstances attempt to defeat the function of the operator control. The blade turns when the engine is running.

- Your lawn mower is equipped with an operator presence control bar which requires the operator to be positioned behind the lawn mower handle to start and operate the lawn mower.

TO ADJUST CUTTING HEIGHT

- All four wheels are adjusted by a single lever.
- Pull adjuster lever toward wheel. To raise mower, move lever forward to desired position. To lower mower, move the lever toward the rear.

Lower Wheels for high cut

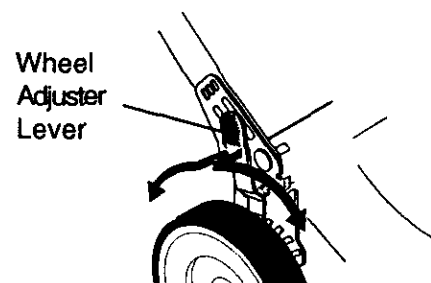

Raise Wheels for low cut

GROUND DRIVE SPEEDS

Your lawn mower provides multiple speeds to let you select the speed that suits you best.

- Lower speeds are for slow, heavy/thick grass cutting or trimming.
- Medium speeds are for normal grass cutting or trimming.
- High is for light cutting and for ground transport.

NOTE: Do not move speed control lever unless the engine is running

TO OPERATE DRIVE SYSTEM

- With engine running, select ground speed by moving speed control lever to desired position.
- To start forward motion, pull drive control bar back against handle.
- To stop forward motion, release drive control bar.

IMPORTANT: Always keep drive control bar fully engaged against handle when in use.

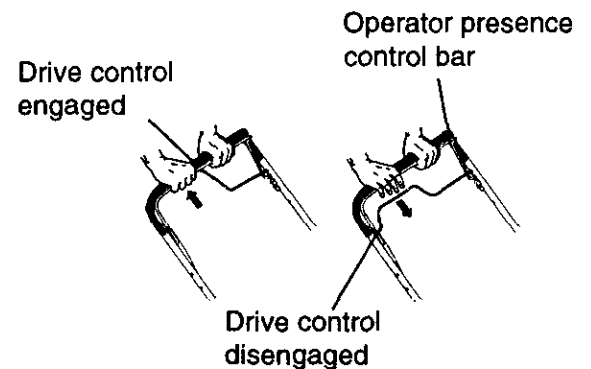
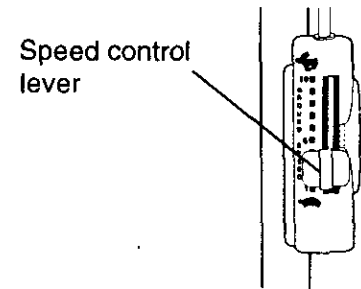

TO CONVERT MOWER

Your lawn mower was shipped ready to be used as a mulcher. To convert to bagging or discharging:

REAR BAGGING-

- Open rear door and remove mulcher plug. Store mulcher plug in a safe place.
- To convert to mulching or discharging operation, install mulcher plug into rear discharge opening of mower.

SIDE DISCHARGING-

- Rear door must be closed.
- Open mulcher door and install discharge deflector under guard as shown.
- Mower is now ready for discharging operation.
- To convert to mulching or bagging operation, discharge deflector must be removed and mulcher door must be closed.

**SIMPLE STEPS TO REMEMBER
WHEN CONVERTING YOUR LAWN
MOWER**

FOR MULCHING -

- Rear mulcher plug installed.
- Mulcher door closed.

FOR REAR BAGGING -

- Rear mulcher plug removed.
- Grass catcher installed.
- Mulcher door closed.

FOR SIDE DISCHARGING -

- Rear mulcher plug installed.
- Side discharge deflector installed.

CAUTION: Do not run your lawn mower without rear mulcher plug in place or approved grass catcher in place. Never attempt to operate the lawn mower with the rear door removed or propped open.

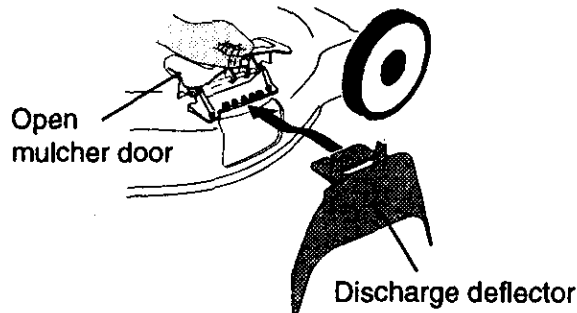
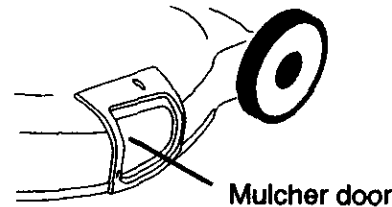
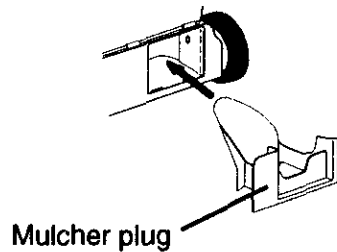

TO ATTACH GRASS CATCHER

- Lift the rear door of the lawn mower and place the grass catcher frame hooks into the slots of the rear door.
- The grass catcher is secured to the lawn mower housing when the rear door is lowered onto the grass catcher frame.

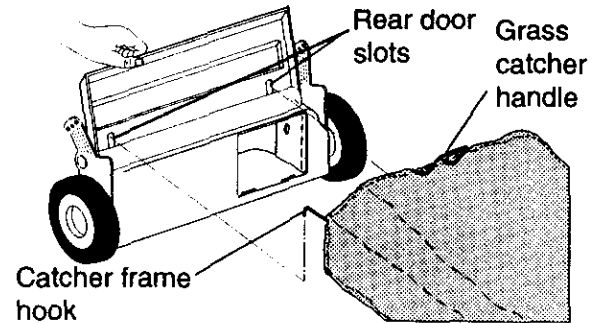

CAUTION: Do not run your lawn mower without rear mulcher plug or approved grass catcher in place. Never attempt to operate the lawn mower with the rear door removed or propped open.

TO EMPTY GRASS CATCHER

- Lift up on grass catcher using the frame handle.
- Remove grass catcher with clippings from under lawn mower handle.
- Empty clippings from bag using both frame handle and bag handle.

NOTE: Do not drag the bag when emptying; it will cause unnecessary wear.

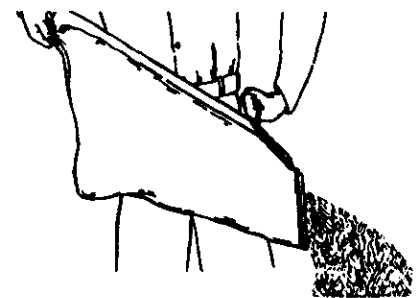

**BEFORE STARTING ENGINE
OIL**

Your lawn mower is shipped without oil in the engine.

- Be sure mower is level and area around oil fill is clean.
- Remove engine oil cap and fill to the full line on the dipstick.

NOTE: Allow oil to settle down into engine for accurate reading.

- Engine holds 20 ozs. of oil. For type and grade of oil to use, see "ENGINE" in maintenance section of this manual.
- Pour oil slowly. Do not over fill.

- Check oil level before each use. Add oil if needed. Fill to full line on dipstick.
- To read proper level, tighten engine oil cap each time.
- Reinstall engine oil cap and tighten.
- Change the oil after every 25 hours of operation or each season. You may need to change the oil more often under dusty, dirty conditions.

ADD GASOLINE

NOTE: Before filling fuel tank, remove and discard the debris plug that is inside the tank.

- Fill fuel tank. Use fresh, clean, regular unleaded gasoline with a minimum of 87 octane (Use of leaded gasoline will increase carbon and lead oxide deposits and reduce valve life). Do not mix oil with gasoline. Purchase fuel in quantities that can be used within 30 days to assure fuel freshness.

⚠WARNING: Experience indicates that alcohol blended fuels (called gasohol or using ethanol or methanol) can attract moisture which leads to separation and formation of acids during storage. Acidic gas can damage the fuel system of an engine while in storage. To avoid engine problems, the fuel system should be emptied before storage of 30 days or longer. Drain the fuel tank, start the engine and let it run until fuel lines and carburetor are empty. Use fresh fuel next season. See Storage Instructions for additional information. Never use engine or carburetor cleaner products in fuel tank or permanent damage may occur.

⚠CAUTION: Fill to bottom of gas tank filler neck. Do not overfill. Wipe off any spilled oil or fuel. Do not store, spill or use gasoline near an open flame.

TO START ENGINE

- To start a cold engine, push primer three (3) times before trying to start. Use a firm push. This step is not usually necessary when starting an engine which has already run for a few minutes.
- Hold operator presence control bar down to the handle.
- To stop engine, release operator presence control bar.

NOTE: In cooler weather it may be necessary to repeat priming steps. In warmer weather over priming may cause flooding and engine will not start. If you do flood engine wait a few minutes before attempting to start and do not repeat priming steps.

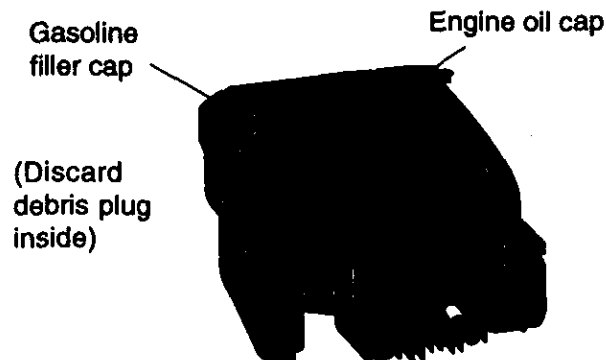

MOWING TIPS

- Under certain conditions, such as very tall grass, it may be necessary to raise the height of cut to reduce pushing effort and to keep from overloading the engine and leaving clumps of grass clippings. It may also be necessary to reduce ground speed and/or run the lawn mower over the area a second time.
- For extremely heavy cutting, reduce the width of cut by overlapping previously cut path and mow slowly.
- For better grass bagging and most cutting conditions, the engine speed should be set in the fast position.
- Pores in cloth grass catchers can become filled with dirt and dust with use and catchers will collect less grass. To prevent this, regularly hose catcher off with water and let dry before using.
- Keep top of engine around starter clear and clean of grass clippings and chaff. This will help engine air flow and extend engine life.

MULCHING MOWING TIPS

IMPORTANT: For best performance, keep mower housing free of built-up grass and trash. See "Cleaning" in MAINTENANCE section of this manual.

- The special mulching blade will recut the grass clippings many times and reduce them in size so that as they fall onto the lawn they will disperse into the grass and not be noticed. Also, the mulched grass will biodegrade quickly to provide nutrients for the lawn. Always mulch with your highest engine (blade) speed as this will provide the best recutting action of the blades.
- Avoid cutting your lawn when it is wet. Wet grass tends to form clumps and interferes with the mulching action. The best time to mow your lawn is the early afternoon. At this time the grass has dried and the newly cut area will not be exposed to the direct sun.
- For best results, adjust the lawn mower cutting height so that the lawn mower cuts off only the top one-third of the grass blades. If the lawn is overgrown it will be necessary to raise the height of cut to reduce pushing effort and to keep from overloading the engine and leaving clumps of mulched grass. For extremely heavy mulching, reduce your width of cut by overlapping previously cut path and mow slowly.
- Certain types of grass and grass conditions may require that an area be mulched a second time to completely hide the clippings. When doing a second cut, mow across or perpendicular to the first cut path.
- Change your cutting pattern from week to week. Mow north to south one week then change to east to west the next week. This will help prevent matting and graining of the lawn.

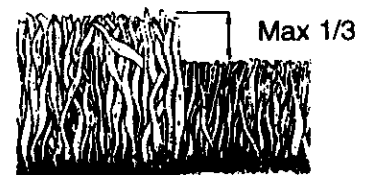

PRODUCT SPECIFICATIONS

SERIAL NUMBER	
DATE OF PURCHASE	
GASOLINE CAPACITY/TYPE:	1.6 QUARTS
UNLEADED REGULAR	
OIL TYPE (API-SF/SG/SH):	SAE 30 (ABOVE 32°F) SAE 5W-30 (BELOW 32°F)
OIL CAPACITY:	20 OZS.
SPARK PLUG(GAP: .030")	CHAMPION RJ19LM or J19LM
VALVE CLEARANCE:	INTAKE: .004 - .008 EXHAUST: .004 - .008
SOLID STATE IGNITION	
AIR GAP:	.0125 IN.
BLADE BOLT TORQUE:	35-40 FT. LBS.
<ul style="list-style-type: none"> The model and serial numbers will be found on a decal attached to the rear of the lawn mower housing. Record both serial number and date of purchase in space provided above. 	

LAWNMOWER

Always observe safety rules when performing any maintenance.

TIRES

- Keep tires free of gasoline, oil, or insect control chemicals which can harm rubber.
- Avoid stumps, stones, deep ruts, sharp objects and other hazards that may cause tire damage.

BLADE CARE

For best results, mower blade must be kept sharp. Replace bent or damaged blades.

TO REMOVE BLADE

- Disconnect spark plug wire from spark plug and place wire where it cannot come in contact with spark plug.
- Turn lawn mower on its side. Make sure air filter and carburetor are up.
- Use a wood block between blade and mower housing to prevent blade from turning when removing blade bolt.
- Protect your hands with gloves and/or wrap blade with heavy cloth.
- Remove blade bolt by turning counter-clockwise.
- Remove blade and attaching hardware (bolt, lock washer and hardened washer).

NOTE: Remove the blade adapter and check the key inside hub of blade adapter. The key must be in good condition to work properly. Replace adapter if damaged.

TO REPLACE BLADE

- Position the blade adapter on the engine crankshaft. Be sure key in adapter and crankshaft keyway are aligned.
- Position blade on the blade adapter aligning the two (2) holes in the blade with the raised lugs on the adapter.
- Be sure the trailing edge of blade (opposite sharp edge) is up toward the engine.
- Install the blade bolt with the lock washer and hardened washer into blade adapter and crankshaft.
- Use block of wood between blade and lawn mower housing and tighten the blade bolt, turning clockwise.
- The recommended tightening torque is 35-40 ft. lbs.

IMPORTANT: BLADE BOLT IS GRADE 8 HEAT TREATED.

TO SHARPEN BLADE

NOTE: We do not recommend sharpening blade - but if you do, be sure the blade is balanced.

Care should be taken to keep the blade balanced. An unbalanced blade will cause eventual damage to lawn mower or engine.

- The blade can be sharpened with a file or on a grinding wheel. Do not attempt to sharpen while on the mower.
- To check blade balance, drive a nail into a beam or wall. Leave about one inch of the straight nail exposed. Place center hole of blade over the head of the nail. If blade is balanced, it should remain in a horizontal position. If either end of the blade moves downward, sharpen the heavy end until the blade is balanced.

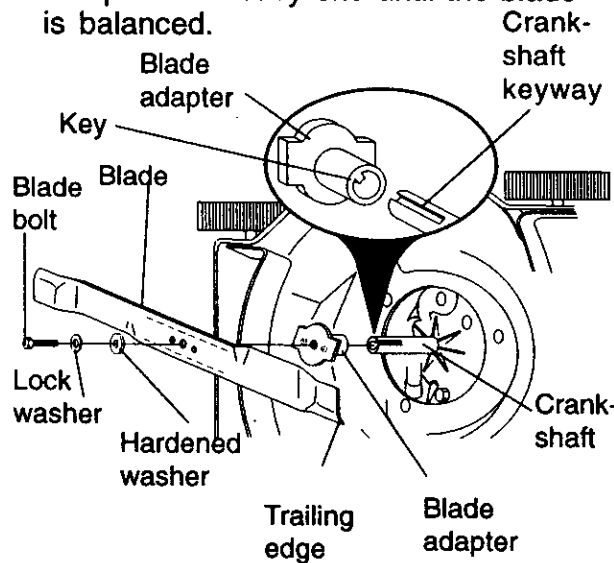

- If you remove the drive pinions, wipe clean with dry cloth. Reassemble dry. Do not lubricate. Do not use oil or grease.
- The pinion gear, on both sides of the mower, are the same, however, they must be installed correctly. If installed incorrectly, the drive system will not work.
- There are arrows embossed on both sides of the pinion gear. With the arrow at the top of the pinion, the arrow must point towards front of mower. If the arrow points to the rear, turn the pinion around and assemble to mower.
- Place wheels back on adjuster axles.
- Replace locknuts and hubcaps.

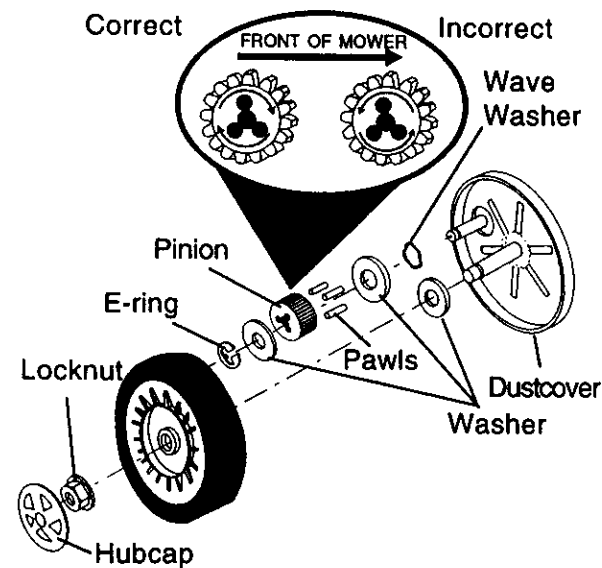

GRASS CATCHER

- The grass catcher may be hosed with water, but must be dry when used.
- Check your grass catcher often for damage or deterioration. Through normal use it will wear. If catcher needs replacing, replace only with a manufacturer approved replacement catcher. Give the lawn mower model number when ordering.

DRIVE WHEELS

Check rear drive wheels each time you mow to be sure they move freely. The wheels not turning freely means trash, grass cuttings, etc., may be inside the drive wheel and dust cover area and must be cleaned out to free drive wheels. If necessary to clean the drive wheels, check both rear wheels:

- Remove hubcaps and locknuts.
- Remove wheels from wheel adjuster axles.
- Remove any trash or grass cuttings from inside the dust cover, pinion and/ or drive wheel gear teeth.

ENGINE LUBRICATION

Use only high quality detergent oil rated with API service classification SF, SG or SH. Select the oil's SAE viscosity grade according to your expected operating temperature.

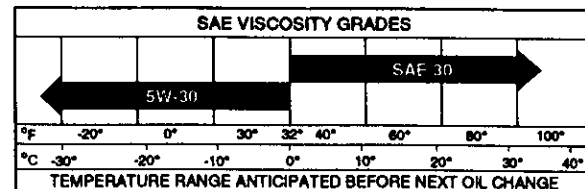

NOTE: Although multi-viscosity oils (5W30, 10W30 etc.) improve starting in cold weather, these multi-viscosity oils will result in increased oil consumption when used above 32°F. Check your engine oil level more frequently to avoid possible engine damage from running low on oil. Change the oil after every 25 hours of operation or at least once a year if the lawn mower is not used for 25 hours in one year.

Check the crankcase oil level before starting the engine and after each five (5) hours of continuous use. Tighten oil plug securely each time you check the oil level.

TO CHANGE ENGINE OIL

NOTE: Before tipping lawn mower to drain oil, drain fuel tank by running engine until fuel tank is empty.

- Disconnect spark plug wire from spark plug and place wire where it cannot come in contact with spark plug.
- Remove engine oil cap; lay aside on a clean surface.
- Tip lawn mower on its side as shown and drain oil into a suitable container. Rock lawn mower back and forth to remove any oil trapped inside of engine.
- Wipe off any spilled oil on lawn mower and on side of engine.
- Fill engine with oil. Fill only to the "FULL" line on the dipstick. **DO NOT OVER FILL.**
- Replace engine oil cap.
- Reconnect spark plug wire to spark plug.

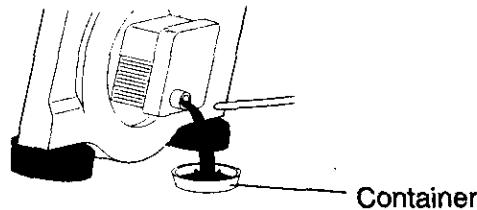

AIR FILTER

Your engine will not run properly and may be damaged by using a dirty air filter. Replace the air filter every year, more often if you mow in very dusty, dirty conditions.

TO CLEAN AIR FILTER

- Loosen screw and tilt cover to remove.
- Carefully remove cartridge.
- Clean by gently tapping on a flat surface. If very dirty, replace cartridge.

CAUTION: Petroleum solvents, such as kerosene, are not to be used to clean cartridge. They may cause deterioration of the cartridge. Do not oil cartridge. Do not use pressurized air to clean or dry cartridge.

- Install cartridge, then replace cover making sure the tabs are aligned with the slots in the back plate. Fasten screw securely.

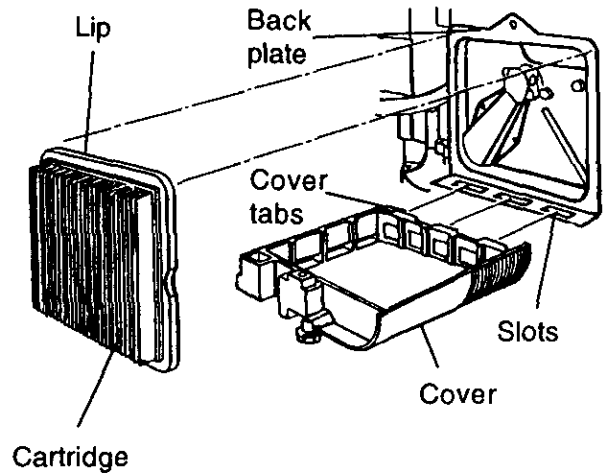

MUFFLER

Inspect and replace corroded muffler as it could create a fire hazard and/or damage.

SPARK PLUG

Change your spark plug each year to make your engine start easier and run better. Set spark plug gap at .030 inch.

CLEANING

IMPORTANT: For best performance, keep mower housing free of built-up grass and trash. Clean underside of mower housing after each use.

CAUTION: Disconnect spark plug wire from spark plug and place wire where it cannot come in contact with the spark plug.

- Clean the underside of your lawn mower by scraping to remove build-up of grass and trash.
- Clean engine often to keep trash from accumulating. A clogged engine runs hotter and shortens engine life.
- Keep finished surfaces and wheels free of all gasoline, oil, etc.
- We do not recommend using a garden hose to clean lawn mower unless the electrical system, muffler, air filter and carburetor are covered to keep water out. Water in engine can result in shortened engine life.

SERVICE AND ADJUSTMENTS

CAUTION: Before performing any service or adjustments:

- Release control bar and stop engine.
- Make sure the blade and all moving parts have completely stopped.
- Disconnect spark plug wire from spark plug and place where it cannot come in contact with plug.

LAWN MOWER

TO ADJUST CUTTING HEIGHT

See "TO ADJUST CUTTING HEIGHT" in the Operation section of this manual.

REAR DEFLECTOR

The rear deflector, attached between the rear wheels of your lawn mower, is provided to minimize the possibility that objects will be thrown out the rear of the lawn mower into the operator's mowing position. If the rear deflector becomes damaged, it should be replaced.

TO ADJUST HANDLE

The handle on your lawn mower has three (3) height positions - adjust to height that suits you.

- Squeeze the bottom ends of lower handle towards each other until the pin in handle can be inserted into one of the three height adjustment holes.

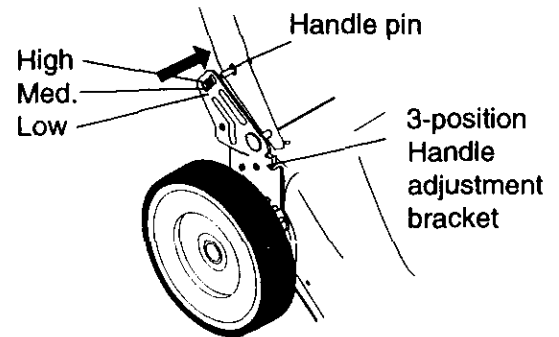

ENGINE

ENGINE SPEED

Your engine speed has been factory set. Do not attempt to increase engine speed or it may result in personal injury. If you believe that the engine is running too fast or too slow, take your lawn mower to an authorized service center/department for repair and adjustment.

CARBURETOR

Your carburetor has a non-adjustable fixed main jet for mixture control. If your engine does not operate properly due to suspected carburetor problems, take your lawn mower to an authorized service center/department for repair and adjustment.

IMPORTANT: Never tamper with the engine governor, which is factory set for proper engine speed. Overspeeding the engine above the factory high speed setting can be dangerous. If you think the engine-governed high speed needs adjusting, contact your nearest authorized service center, which has proper equipment and experience to make any necessary adjustments.

STORAGE

Immediately prepare your lawn mower for storage at the end of the season or if the unit will not be used for 30 days or more.

LAWN MOWER

When lawn mower is to be stored for a period of time, clean it thoroughly, remove all dirt, grease, leaves, etc. Store in a clean, dry area.

- Clean entire lawn mower (See "CLEANING" in the Maintenance section of this manual).
- Lubricate as shown in the Maintenance section of this manual.
- Be sure that all nuts, bolts, screws, and pins are securely fastened. Inspect moving parts for damage, breakage and wear. Replace if necessary.
- Touch up all rusted or chipped paint surfaces; sand lightly before painting.

HANDLE

- You can fold your lawn mower handle for storage.
- Loosen the two (2) handle knobs on sides of the upper handle and allow handle to fold down to the rear.
- Squeeze the bottom ends of lower handle toward each other until pins in handle clear the brackets and pivot entire handle assembly forward and allow it to rest on mower.
- When setting up your handle from the storage position, the lower handle will require manually locking into the mowing position.

IMPORTANT: When folding the handle for storage or transportation be sure to fold the handle as shown or you may damage the control cables.

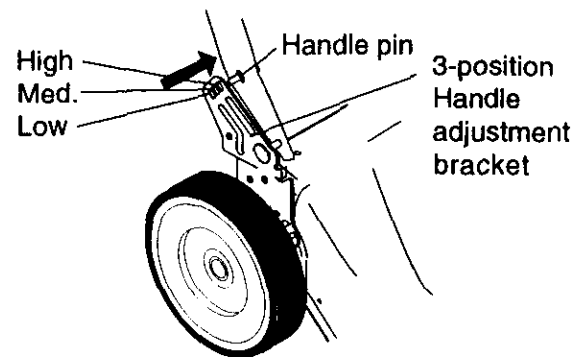
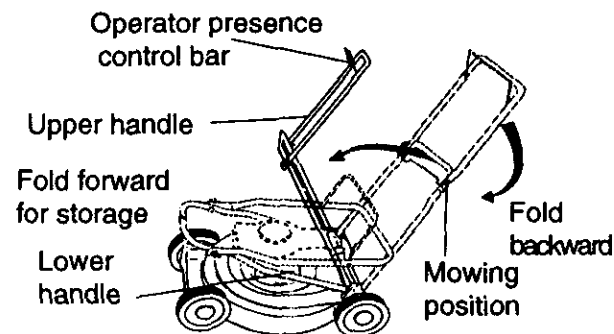

ENGINE

FUEL SYSTEM

IMPORTANT: It is important to prevent gum deposits from forming in essential fuel system parts such as carburetor, fuel filter, fuel hose, or tank during storage. Also, experience indicates that alcohol blended fuels (called gasohol or using ethanol or methanol) can attract moisture which leads to separation and formation of acids during storage. Acidic gas can damage the fuel system of an engine while in storage.

- Drain the fuel tank.
- Start the engine and let it run until the fuel lines and carburetor are empty.
- Never use engine or carburetor cleaner products in the fuel tank or permanent damage may occur.
- Use fresh fuel next season.

NOTE: Fuel stabilizer is an acceptable alternative in minimizing the formation of fuel gum deposits during storage. Add stabilizer to gasoline in fuel tank or storage container. Always follow the mix ratio found on stabilizer container. Run engine at least 10 minutes after adding stabilizer to allow the stabilizer to reach the carburetor. Do not drain the gas tank and carburetor if using fuel stabilizer.

ENGINE OIL

Drain oil (with engine warm) and replace with clean engine oil. (See "ENGINE" in the Maintenance section of this manual).

CYLINDER

- Remove spark plug.
- Pour one ounce (29 ml) of oil through spark plug hole into cylinder.
- Pull starter handle slowly a few times to distribute oil.
- Replace with new spark plug.

OTHER

- Do not store gasoline from one season to another.

- Replace your gasoline can if your can starts to rust. Rust and/or dirt in your gasoline will cause problems.
- If possible, store your unit indoors and cover it to give protection from dust and dirt.
- Cover your unit with a suitable protective cover that does not retain moisture. Do not use plastic. Plastic cannot breathe which allows condensation to form and will cause your unit to rust.

IMPORTANT: Never cover mower while engine and exhaust areas are still warm.

CAUTION: Never store the lawn mower with gasoline in the tank inside a building where fumes may reach an open flame or spark. Allow the engine to cool before storing in any enclosure.

TROUBLESHOOTING CHART

PROBLEM	CAUSE	CORRECTION
Will not start	<ol style="list-style-type: none"> 1. Dirty air filter. 2. Out of fuel. 3. Stale fuel. 4. Water in fuel. 5. Spark plug wire is disconnected 6. Bad spark plug. 7. Loose blade or broken blade adapter. 8. Control bar in released position 9. Control bar defective 	<ol style="list-style-type: none"> 1. Clean/replace air filter. 2. Fill fuel tank. 3. Drain tank and refill with fresh clean fuel. 4. Drain fuel tank and carburetor and refill tank with fresh gasoline. 5. Connect wire to plug. 6. Replace spark plug. 7. Tighten blade bolt or replace blade adapter. 8. Depress control bar to handle. 9. Replace control bar.
Loss of power	<ol style="list-style-type: none"> 1. Rear of lawn mower housing/blade dragging in heavy grass. 2. Cutting too much grass. 3. Dirty air filter. 4. Buildup of grass, leaves and trash under mower. 5. Too much oil in engine. 6. Walking speed too fast. 	<ol style="list-style-type: none"> 1. Set in "Higher Cut" position. 2. Set in "Higher Cut" position. 3. Clean/replace air filter. 4. Clean underside of mower housing 5. Check oil level. 6. Cut at slower walking speed.
Poor cut - uneven	<ol style="list-style-type: none"> 1. Worn, bent or loose blade. 2. Buildup of grass, leaves, and trash under mower. 	<ol style="list-style-type: none"> 1. Replace blade. Tighten blade bolt. 2. Clean underside of mower housing
Excessive vibration	<ol style="list-style-type: none"> 1. Worn, bent or loose blade. 2. Bent engine crankshaft. 	<ol style="list-style-type: none"> 1. Replace blade. Tighten blade bolt. 2. Contact an authorized service center/department.
Starter rope hard to pull	<ol style="list-style-type: none"> 1. Engine flywheel brake is on when control bar is released. 2. Bent engine crankshaft 3. Blade adapter broken. 4. Blade dragging in grass. 	<ol style="list-style-type: none"> 1. Depress control bar to upper handle before pulling starter rope. 2. Contact an authorized service center/department. 3. Replace blade adapter. 4. Move lawn mower to cut grass or to hard surface to start engine.

TROUBLESHOOTING CHART

PROBLEM	CAUSE	CORRECTION
Grass catcher not filling (If so equipped)	<ol style="list-style-type: none"> 1. Cutting height too low. 2. Lift on blade worn off. 3. Catcher not venting air. 	<ol style="list-style-type: none"> 1. Raise cutting height. 2. Replace blade. 3. Clean grass catcher.
Hard to push	<ol style="list-style-type: none"> 1. Grass is too high or wheel height is too low. 2. Rear of lawn mower housing/blade dragging in grass. 3. Grass catcher too full. 4. Handle height position not right for you. 	<ol style="list-style-type: none"> 1. Raise cutting height. 2. Raise rear of lawn mower housing one (1) setting higher. 3. Empty grass catcher. 4. Adjust handle height to suit.
Loss of drive	<ol style="list-style-type: none"> 1. Belt wear. 2. Belt off of pulley. 3. Drive cable worn or broken. 4. Dirt in drive pinions. 	<ol style="list-style-type: none"> 1. Check/replace drive belt. 2. Check/reinstall drive belt. 3. Replace drive cable. 4. Clean drive pinions.

SERVICE NOTES

ROTARY LAWN MOWER -- MODEL NO. 917.377160

KEY NO.	PART NO	DESCRIPTION	KEY NO.	PART NO	DESCRIPTION
1	167163	Handle, Upper Dlx Comf. (Includes Grip)	39	169294	Grass Catcher Bag
2	161105X479	Handle, Lower	40	161358	Grass Catcher Frame
3	131036	Bail, Cont. Wire Dlx Comf. Blk	41	85463	Danger Decal
4	132001	Guide, Rope, Side	42	144929	Screw
5	63601	Nut, Hex Lockwasher 1/4-20	43	63601	Nut
6	66426	Wire, Tie	45	166034	Rod, Pulley Engage
7	131959	Bolt, Handle 5/16-18 x 1.75	46	166041	Bushing
8	87692	Knob, Handle	48	169605	Retainer Clip
9	164265	Grip, Hdl Foam Smooth	49	166039X008	Clamp
10	161551	Bolt, Sq. Neck	50	54583	Screw
11	73990500	Nut, Hex Lockwasher Ins. 5/16-18 UNC	51	169980	Spacer
12	51793	Cotter, Hairpin	52	170868	Wave Washer
13	133107	Engine Zone Control Cable	53	173041	Belt Cover, Bottom
14	850733X004	Bracket, Upstop	54	750097	Screw
15	83816	Screw, Hex Washer Head Tapping 10-2	55	166383X479	Cable Support Bracket
16	162085	Kit, Door Rear	56	63601	Nut
17	161548	Seal, Door	57	166391X004	Bracket Assy.
18	165261	Plug, Mulcher	58	57808	Screw
19	166907	Kit, Housing	59	166042	V-Groove Pulley
20	161568X479	Handle, Bracket Asm. Left	60	166050	Idler Arm Spacer
21	168227X479	Handle, Bracket Asm. Right	61	145212	Flange Nut
22	150078	Screw, Hex Wshd	62	155552	Locknut
23	163183	Bolt, Hex Head 5/16-18 x 5/8	63	166022X008	Idler Arm
24	63124	Nut, Hex Lock Wshr 5/16-18	64	166043	Idler Pulley
25	161333	Baffle, Side	65	160829	Shoulder Bolt
26	163409	Screw 12 x 5/8	66	171962	Door Assy.
27	161550	Rear Skirt	67	88349	Nut
28	88652	Screw	68	166028	Multi Cut Guard
29	166036X479	Belt Cover, Top	69	54583	Screw
30	851514	Adapter, Blade w/key Longer	71	164137	Throttle Control
31	159267	Blade, 21"	72	111190X	Engine Clamp
32	851074	Washer, Hardened	73	83816	Screw
33	850263	Lockwasher, Helical Spring 3/8	76	87677	Hi Pro Key
34	851084	Screw, Hex Head 3/8-24 x 1.38	--	161058	Warning Decal (Not Shown)
35	169809	Pulley, Fixed	--	170961	Owners's Manual
36	170045	Bearing Support Assy.			
37	150406	Bolt, Engine			
38	-----	Engine Briggs and Stratton 12H802-2682-B1 (See Breakdown)			



ROTARY LAWN MOWER -- MODEL NO. 917.377160

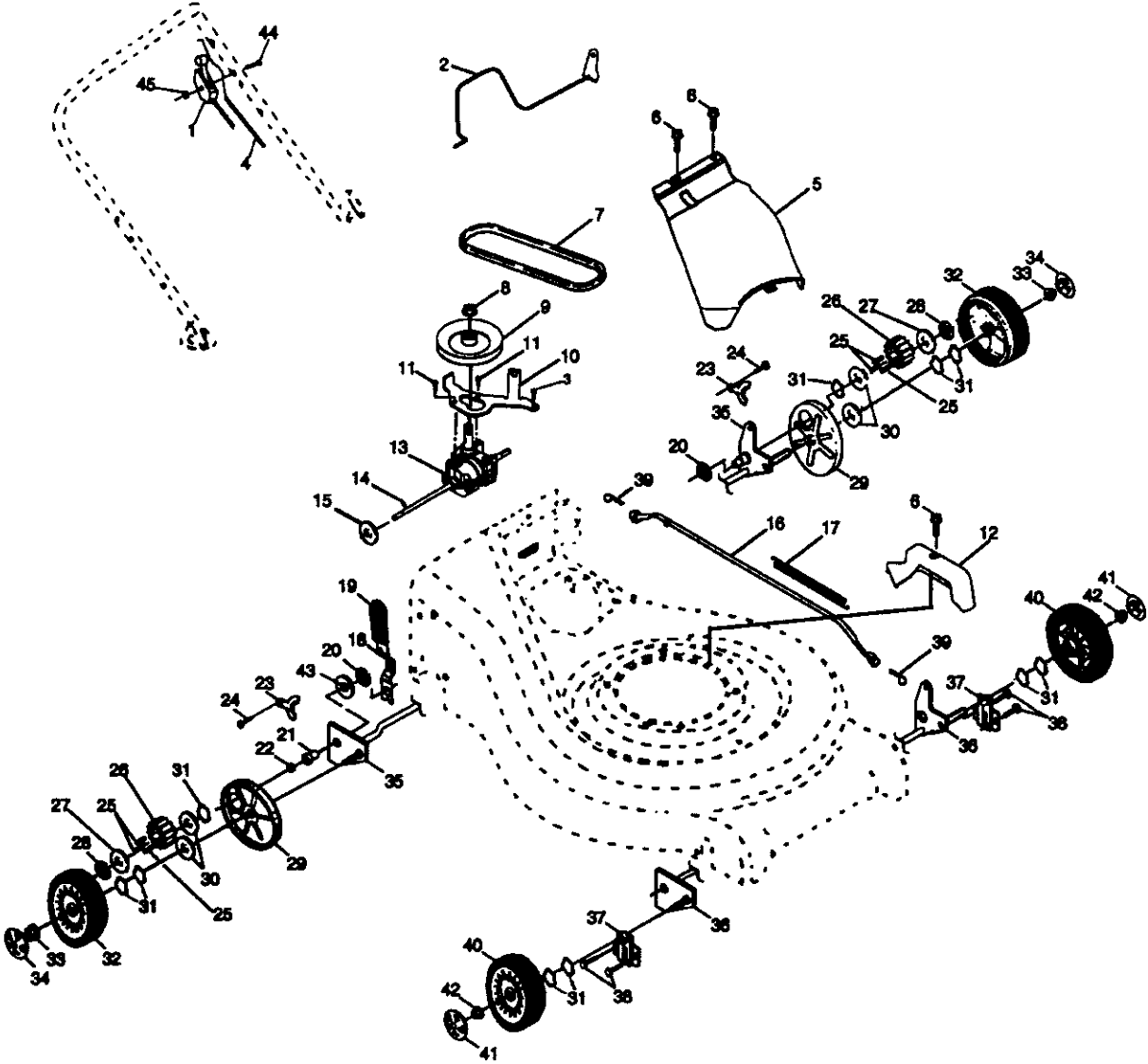

ROTARY LAWN MOWER -- MODEL NO. 917.377160

KEY NO.	PART NO	DESCRIPTION	KEY NO.	PART NO	DESCRIPTION
1	170960	Speed Control	23	161118X004	Retainer Drive Asm. Stmp.
2	167259	Bail Control Drive	24	57808	Screw Hex Head Tapping 1/4-20 x .75
3	17060408	Screw	25	170011	Drive Pawl
4	170050	Drive Cable	26	166450	Pinion, Drive
5	161537	Cover Drive	27	52160	Washer
6	750634	Screw Thdrol 10-25 x .50	28	12000058	E-Ring 7/16
7	166060	V-Belt	29	88080	Cover, Dust Wheel
8	132010	Nut Lock Flanged 3/8-16 Zinc	30	67725	Washer 1/2 x 1-1/2 x .134
9	166049	Pulley Driven	31	57143	Wave Washer
10	166021X004	Belt Keeper Bracket	32	172324	Wheel 9 x 2
11	17541011	Screw Hex Wash Head 10-24 X .668	33	145212	Nut Hex Flange Lock
12	166189	Pivot Rod Cover	34	150181	Hubcap, Mag Platinum 9"
13	166388	Transmission Asm.	35	160785X004	Shaft Asm. Rear
14	145354	Pin Spring Thrust	36	160786X004	Shaft Asm. Front
15	57079	Washer Hardened	37	161463	Retainer Front Shaft
16	161584X479	Rod Connecting	38	163409	Screw 12 x 5/8
17	161602	Spring Extension	39	700279	Clip Retainer
18	160477X004	Spring Selector	40	172323	Wheel 8 x 2
19	167650	Knob Selector Spring	41	150182	Hubcap, Mag Platinum 8"
20	12000022	E-Ring 7/8	42	83923	Nut, Hex Flange Lock 3/8-16
21	163365	Bearing Support	43	19572216	Washer
22	169911	Bearing Ball	44	144929	Screw 1/4 x 2.12
			45	751152	Locknut



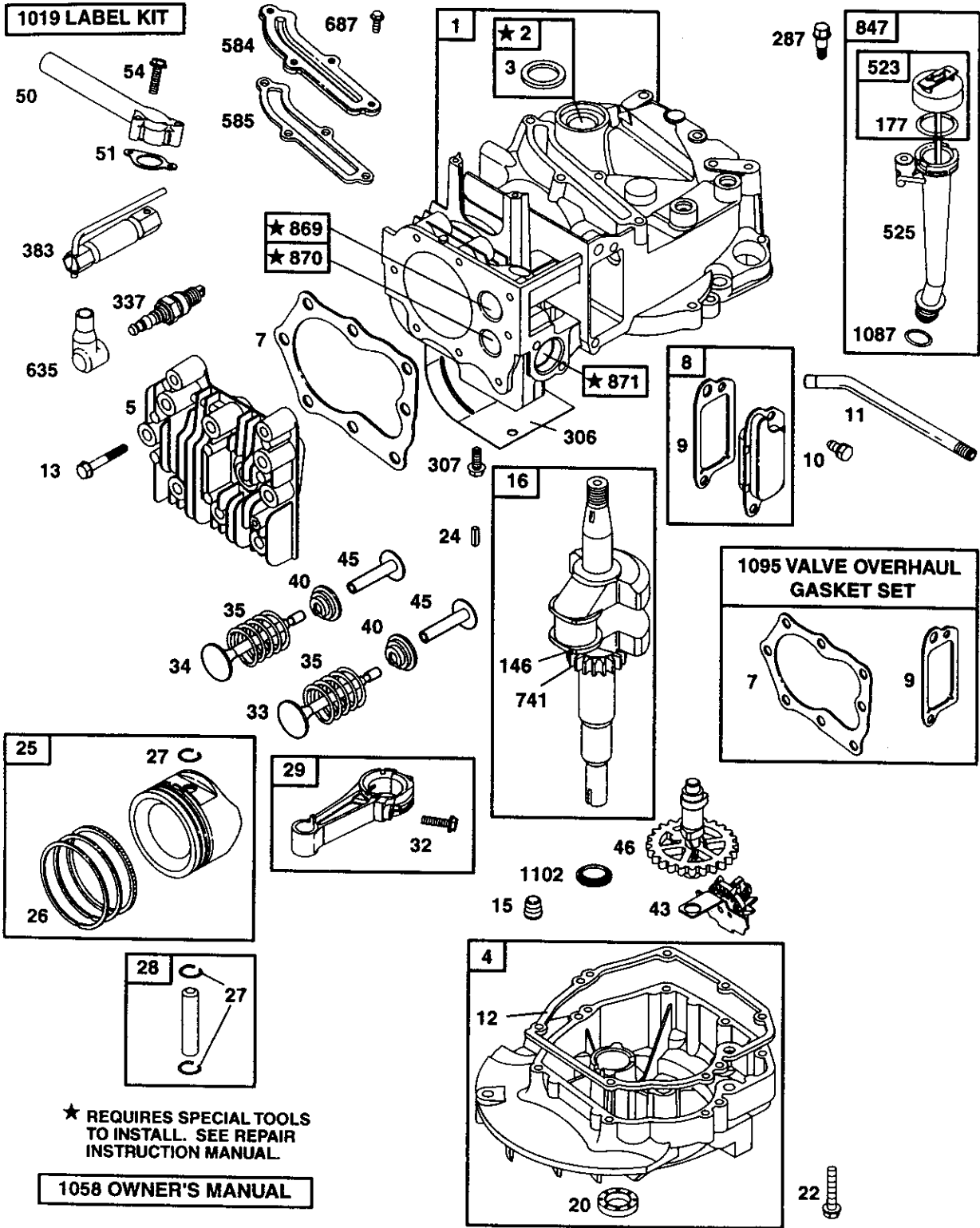

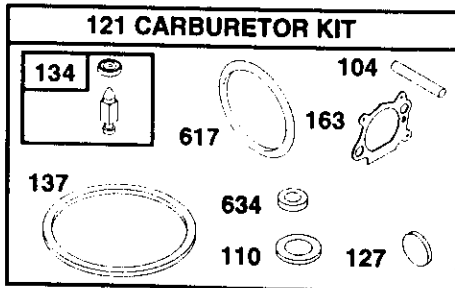
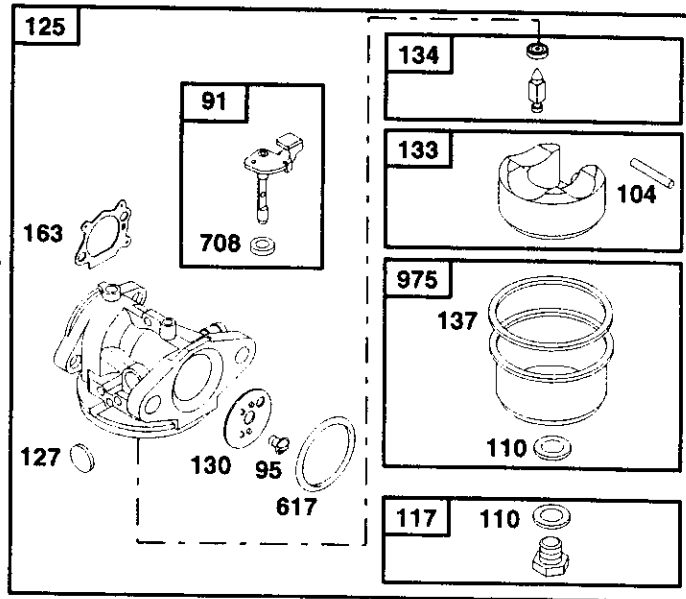
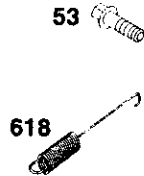
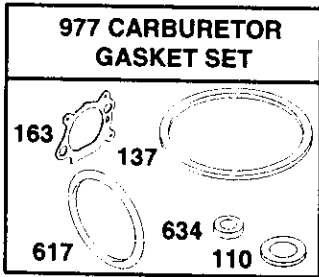
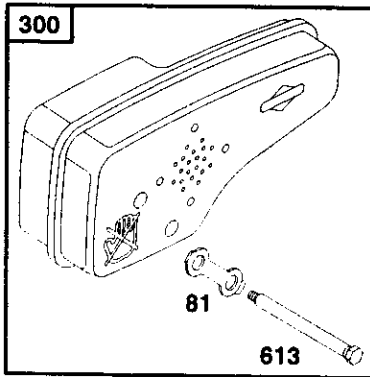
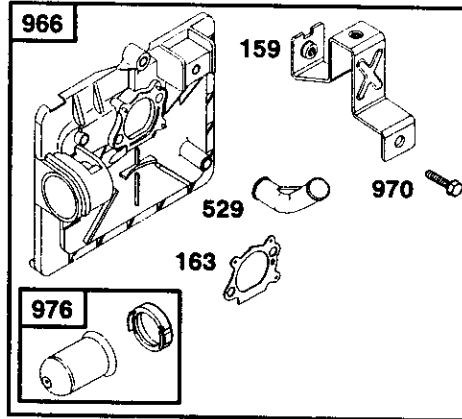
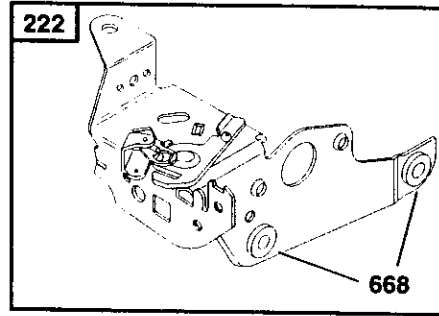
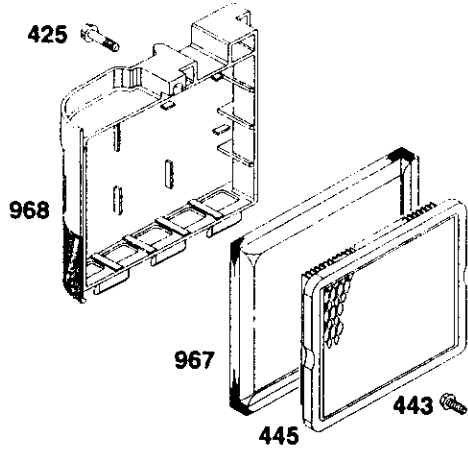

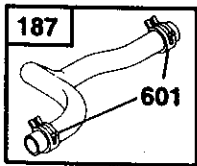
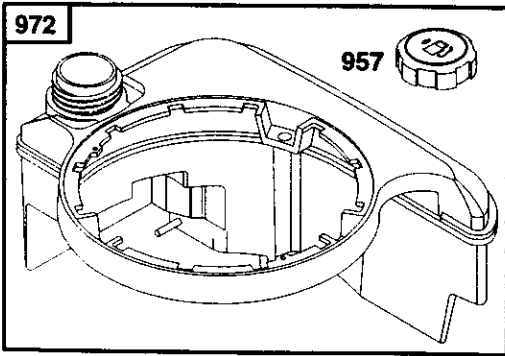
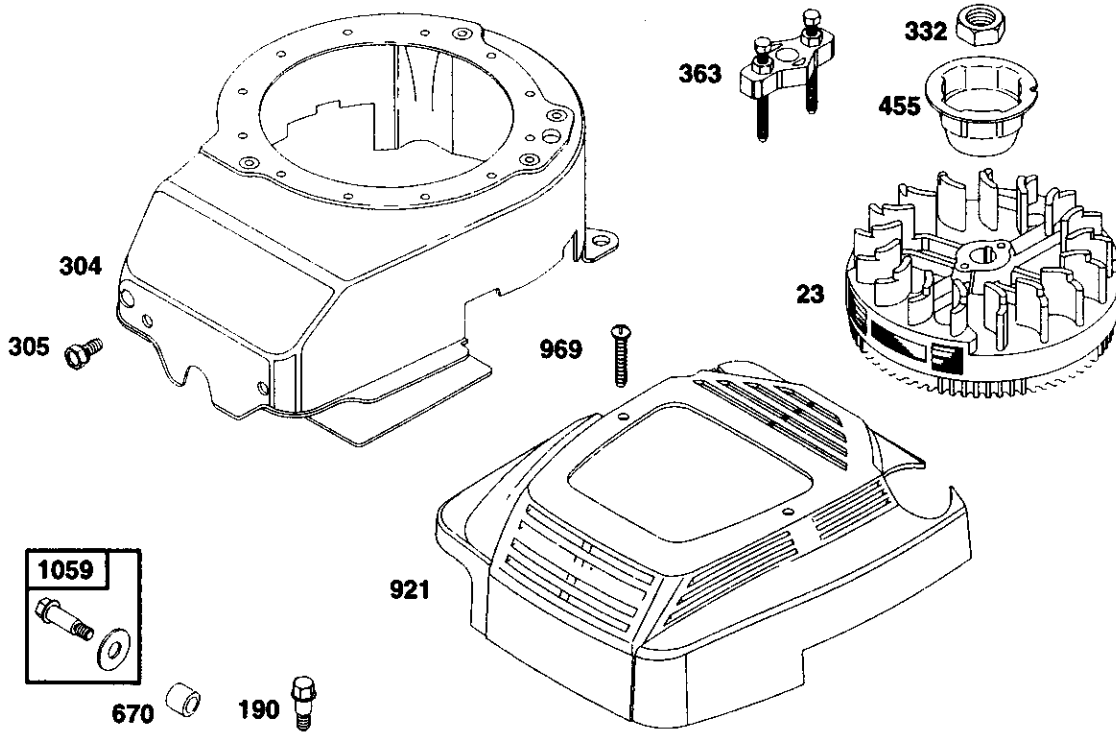

1036 LABEL KIT-EMISSION

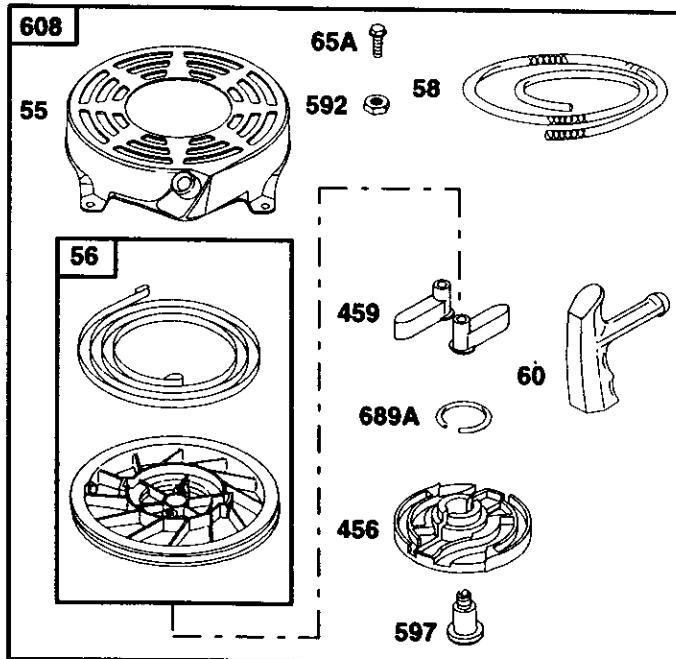

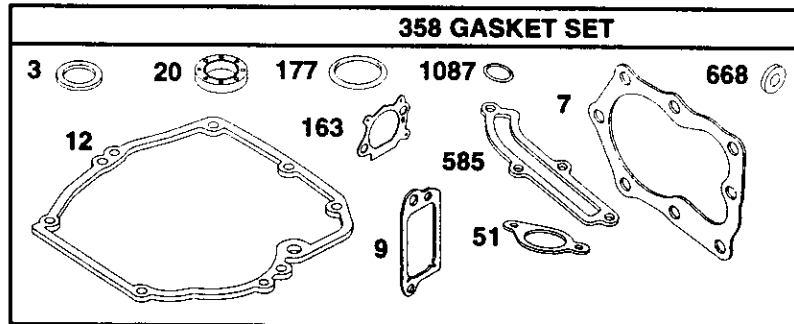
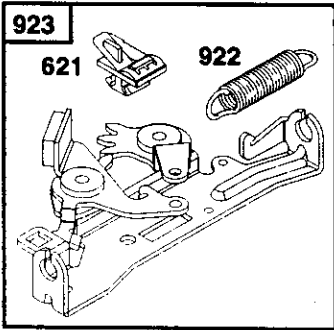
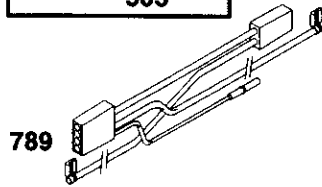
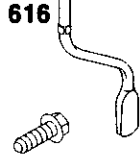
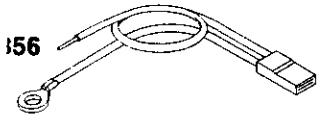
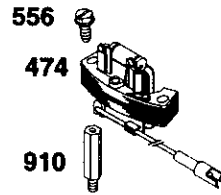
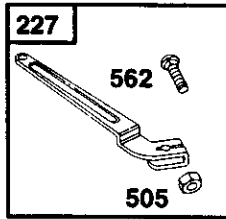
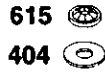
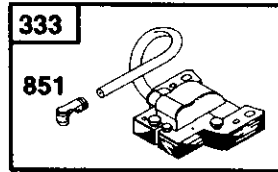
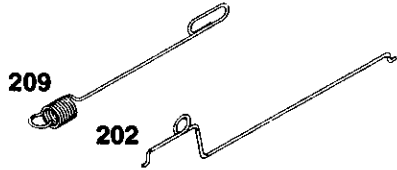
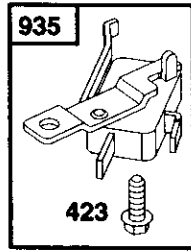

KEY NO.	PART NO.	DESCRIPTION	KEY NO.	PART NO.	DESCRIPTION
1	493260	Cylinder Assembly	81	223664	Muffler Screw Lock
2	293708	Bushing/Seal Kit	95	94098	Screw (Throttle Valve)
3	299819	★ Oil Seal	97	493267	Throttle Shaft
4	493279	Engine Sump	104	231371	● Float Hinge Pin
5	691160	Cylinder Head	110	— — —	●◆ Washer (Sold in Kit Only)
7	272916	★+ Cylinder Head Gasket	117	494870	Main Jet
8	495786	Breather Assembly	121	498260	Carburetor Kit
9	272481	★+ Breather Gasket	125	498170	Carburetor
10	94650	Screw (Breather Assembly)	127	— — —	● Welch Plug
11	231933	Breather Tube			(Sold in Kit Only)
12	272198	★ Crankcase Gasket	130	224908	Throttle Valve
13	94547	Screw (Cylinder Head)	133	398187	Carburetor Float
15	691680	Oil Drain Plug	134	398188	● Needle Valve
16	498565	Crankshaft			(Includes Seat)
20	399781	★ Oil Seal	137	— — —	●◆ Float Bowl Gasket
22	691092	Screw (Engine Sump)			(Sold in Kit Only)
23	492177	Flywheel	146	94388	Timing Key
24	222698	Flywheel Key	159	224815	Support Bracket
25	499429	Piston Assembly (Standard)	163	272653	★● Air Cleaner Gasket
	499430	Piston Assy. (.010" O.S.)	177	280393	★ O-Ring Seal
	499431	Piston Assy. (.020" O.S.)	187	492790	Fuel Line
	499432	Piston Assy. (.030" O.S.)	188	693399	Screw (Control Bracket)
26	499425	Ring Set (Standard)	190	94511	Screw (Fuel Tank)
	499426	Ring Set (.010" O.S.)	202	262579	Mechanical Governor Link
	499427	Ring Set (.020" O.S.)	209	263044	Governor Spring
	499428	Ring Set (.030" O.S.)	222	497203	Control Bracket
27	263190	Piston Pin Lock	227	690783	Governor Lever
28	499423	Piston Pin	258	94512	Screw (Brake)
29	499424	Connecting Rod	287	94511	Screw (Oil Fill Tube)
32	94699	Screw (Connecting Rod)	300	497838	Exhaust Muffler
33	262651	Exhaust Valve	304	493293	Blower Housing
34	262652	Intake Valve	305	691108	Screw (Blower Housing)
35	691270	Valve Spring	306	690450	Cylinder Shield
40	93312	Valve Retainer			
43	493737	Governor/Oil Slinger			
45	690548	Valve Tappet			
46	691449	Cam Gear			
50	497465	Intake Manifold			
51	272199	★ Intake Gasket			
53	692524	Screw (Carburetor)			
54	94526	Screw (Intake Manifold)			
55	691421	Rewind Starter Housing			
56	498144	Starter Pulley			
57	498144	Rewind Starter Spring			
58	281464	Starter Rope			
		(Cut to Required Length)			
60	281434	Starter Rope Grip			
65A	94904	Screw			
		(Rewind Starter Housing)			

RPM Settings:

Low Speed: 1900-2100
High Speed: 3000-3200

- ★ Included in Gasket Set, Ref Number 358.
- Included in Carburetor Kit, Ref Number 121.
- ◆ Included in Carburetor Gasket Set, Ref Number 977.
- + Included in Valve Overhaul Kit, Ref Number 1095.

NOTE: All component dimensions given in U.S. inches 1 inch = 25.4 mm



KEY NO.	PART NO.	DESCRIPTION	KEY NO.	PART NO.	DESCRIPTION
307	690345	Screw (Cylinder Shield)	670	280512	Fuel Tank Spacer
332	94877	Nut (Flywheel)	687	94515	Screw
333	802574	Magneto Armature			(Breather Passage Cover)
334	94731	Screw (Magneto Armature)	689A	263073	Friction Spring
337	802592	Spark Plug	708	691321	● Throttle Shaft Seal
356	497833	Stop Wire	741	262598	Timing Gear
358	497316	Gasket Set	789	493380	Wiring Harness
363	19069	Flywheel Puller	847	495263	Dipstick/Tube Assembly
383	89838	Spark Plug Wrench	851	493880	Cable Terminal
404	690272	Washer (Governor Crank)	869	691155	Valve Seat (Intake)
423	93758	Screw (Interlock Switch)	870	690380	Valve Seat (Exhaust)
425	94872	Screw (Air Cleaner Cover)	871	63709	Guide Bushing
443	94873	Screw (A/C Primer Base)			(Intake Valve)
445	491588	A/C Cartridge Filter		262001	Guide Bushing
455	225121	Flywheel Cup			(Exhaust Valve)
456	281503	Pawl Friction Plate	910	94510	Stud (Alternator)
459	281505	Ratchet Pawl	921	497233	Blower Housing Cover
474	492841	Alternator	922	262640	Brake Spring
505	231082	Nut (Governor Lever)	923	691994	Brake
523	495264	Dipstick	935	398758	Interlock Switch
525	495265	Oil Fill Tube	957	397974	Fuel Tank Cap
529	281299	Grommet	966	496116	A/C Primer Base
556	94512	Screw (Alternator)	967	493537	Pre Cleaner Filter
562	92613	Bolt (Governor Lever)	968	281340	Air Cleaner Cover
584	692342	Breather Passage Cover	969	94696	Screw
585	272238	★ Breather Passage Gasket			(Blower Housing Cover)
592	94908	Nut	970	94749	Screw (Support Bracket)
		(Rewind Starter Housing)	972	495224	Fuel Tank
597	94943	Screw (Pawl Friction Plate)	975	493640	Float Bowl
601	93053	Fuel Line Clamp	976	496115	Carburetor Primer
608	497680	Rewind Starter	977	498261	Carburetor Gasket Set
613	94231	Screw (Exhaust Muffler)	1019	494256	Label Kit
615	690340	Retainer	1036	695111	Label Kit-Emission
616	691306	Governor Crank	1058	273693	Owner's Manual
617	270344	● Intake Manifold Seal	1059	398540	Screw/Washer Kit
618	262749	Spring	1087	280966	★ O-Ring Seal
621	396847	Stop Switch	1095	498528	Valve Overhaul Gasket Set
635	66538	Spark Plug Boot	1102	232153	Guide Pilot
668	493823	★ Spacer (Includes 2)	— —	12J802-1915-E1	Replacement Engine

RPM Settings: Low Speed: 1900-2100
High Speed: 3000-3200

- ★ Included in Gasket Set, Ref Number 358.
- Included in Carburetor Kit, Ref Number 121.
- ◆ Included in Carburetor Gasket Set, Ref Number 977.
- + Included in Valve Overhaul Kit, Ref Number 1095.

NOTE: All component dimensions given in U.S. inches
1 inch = 25.4 mm



Get it fixed, at your home or ours!

For repair of major brand appliances **in your own home...**
no matter who made it, no matter who sold it!

1-800-4-MY-HOME SM Anytime, day or night
(1-800-469-4663)

www.sears.com

To bring in products such as vacuums,
lawn equipment and electronics for repair, call for
the location of your nearest **Sears Parts & Repair Center.**

1-800-488-1222 Anytime, day or night

www.sears.com

For the replacement parts, accessories and owner's manuals
that you need to do-it-yourself, call **Sears PartsDirect** SM!

1-800-366-PART 6 a.m. – 11 p.m. CST,
(1-800-366-7278) 7 days a week

www.sears.com/partsdirect

To purchase or inquire about a Sears Service Agreement:

1-800-827-6655

7 a.m. – 5 p.m. CST, Mon. – Sat.

Para pedir servicio de reparación a domicilio,
y para ordenar piezas con entrega a domicilio:

1-888-SU-HOGAR SM
(1-888-784-6427)

Au Canada pour service en français:

1-877-LE-FOYER SM
(1-877-533-6937)



© Sears, Roebuck and Co.

® Registered Trademark / TM Trademark of Sears, Roebuck and Co.
® Marca Registrada / TM Marca de Fábrica de Sears, Roebuck and Co.