

# Built-in Oven

## User & installation manual

NV75J7570RS



**SAMSUNG**

# Contents

---

<b>Using this manual</b>	<b>4</b>
The following symbols are used in this User Manual:	4
<b>Safety instructions</b>	<b>5</b>
Important safety precautions	5
Auto energy saving function	9
<b>Installation</b>	<b>10</b>
What's included	10
Power connection	12
Cabinet mount	13
<b>Before you start</b>	<b>16</b>
Initial settings	16
New oven smell	17
Smart safety mechanism	17
Soft Closing Door (Gentle, Safe, and Silent)	17
Accessories	18
Dual cook mode	20
<b>Operations</b>	<b>21</b>
Control panel	21
Common settings	22
Cooking modes (except for Grill)	28
Cooking modes (Grill)	31
Dual cook mode temperature setting range	33
To stop cooking	35
Special function	36
Auto cook	37
Cleaning	39
Timer	42
Sound On/Off	42

---

<b>Cooking Smart</b>	<b>43</b>
Manual cooking	43
Auto cook programmes	50
Test Dishes	58
Collection of frequent Auto cook recipes	60
<b>Maintenance</b>	<b>64</b>
Cleaning	64
Replacement	70
<b>Troubleshooting</b>	<b>71</b>
Checkpoints	71
Information codes	74

# Using this manual

---

Thank you for choosing SAMSUNG Built-In Oven.

This User Manual contains important information on safety and instructions intended to assist you in the operation and maintenance of your appliance.

Please take the time to read this User Manual before using your oven and keep this book for future reference.

## The following symbols are used in this User Manual:

---

### WARNING

Hazards or unsafe practices that may result in **severe personal injury, death and/or property damage**.

### CAUTION

Hazards or unsafe practices that may result in **personal injury and/or property damage**.

### NOTE

Useful tips, recommendations, or information that helps users manipulate the product.

# Safety instructions

---

Installation of this oven must be performed only by a licensed electrician. The installer is responsible for connecting the appliance to the mains power supply in observance of the relevant safety recommendations.

## Important safety precautions

---

### WARNING

This appliance is not intended for use by persons (including children) with reduced physical, sensory or mental capabilities, or lack of experience and knowledge, unless they have been given supervision or instruction concerning use of the appliance by a person responsible for their safety.

Children should be supervised to ensure that they do not play with the appliance.

If the supply cord is defective, it must be replaced by a special cord or assembly available from the manufacturer or an authorized service agent. (Fixed wiring type model only)

If the supply cord is damaged, it must be replaced by the manufacturer, its service agent or similarly qualified persons in order to avoid a hazard. (Power cord type model only)

This Appliance should be allowed to disconnection from the supply after installation. The disconnection may be achieved by having the plug accessible or by incorporating a switch in the fixed wiring in accordance with the wiring rules.

The method of fixing is not to depend on the use of adhesives since they are not considered to be a reliable fixing means.

During use the appliance becomes hot. Care should be taken to avoid touching heating elements inside the oven.



# Safety instructions

---

Accessible parts may become hot during use. Young children should be kept away.

If this appliance has steam or self cleaning function, excess spillage must be removed before cleaning and all utensils should not be left in the oven during steam cleaning or self cleaning. The cleaning function depends on the model.

If this appliance has self cleaning functions, during self cleaning the surfaces may get hotter than usual and children should be kept away. The cleaning function depends on the model.

Only use the temperature probe recommended for this oven. (Meat probe model only)

A steam cleaner is not to be used.

**Ensure that the appliance is switched off before replacing the lamp to avoid the possibility of electric shock.**

Do not use harsh abrasive cleaners or sharp metal scrapers to clean the oven door glass since they can scratch the surface, which may result in the glass shattering.

**The appliance and its accessible parts become hot during use. Care should be taken to avoid touching heating elements. Children less than 8 years of age shall be kept away unless continuously supervised.**

This appliance can be used by children aged from 8 years and above and persons with reduced physical, sensory or mental capabilities or lack of experience and knowledge if they have been given supervision or instruction concerning use of the appliance in a safe way and understand the hazards involved. Children should not play with the appliance. Cleaning and user maintenance should not be made by children without supervision.



The temperature of external surfaces may be high when the appliance is operating.

The door or the outer surface may get hot when the appliance is operating.

Keep the appliance and its cord out of reach of children less than 8 years.

Appliances are not intended to be operated by means of an external timer or separate remote-control system.

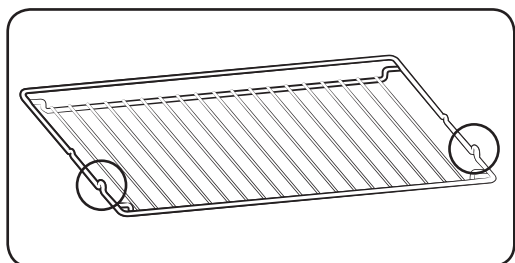

Insert the wire rack into position with the protruding parts (stoppers on both sides) towards the front so that the wire rack supports the rest position for large loads.

### CAUTION

If the oven has been damaged in transport, do not connect it.

This appliance must be connected to the mains power supply only by a specially licensed electrician.

In the event of a fault or damage to the appliance, do not attempt to operate it.

Repairs should be performed by a licensed technician only. Improper repair may result in considerable danger to you and others. If your oven needs repair, contact a SAMSUNG Service center or your dealer.

Electrical leads and cables should not be allowed to touch the oven.

The oven should be connected to the mains power supply by means of an approved circuit breaker or fuse. Never use multiple plug adapters or extension leads.

The power supply of the appliance should be turned off when it is being repaired or cleaned.

Take care when connecting electrical appliances to sockets near the oven.

If this appliance has a vapour or steam cooking function, do not operate this appliance when the water supply cartridge is damaged. (Vapour or steam function model only)



# Safety instructions

---

When the cartridge is cracked or broken, do not use it and contact your nearest service center. (Vapour or steam function model only)

This oven has been designed only for the cooking of household foods.

During use, the oven interior surfaces become hot enough to cause burns. Do not touch heating elements or interior surfaces of the oven until they have had time to cool.

Never store flammable materials in the oven.

The oven surfaces become hot when the appliance is operated at a high temperature for an extended period of time.

When cooking, take care when opening the oven door as hot air and steam can escape rapidly.

When cooking dishes that contain alcohol, the alcohol may evaporate due to the high temperatures and the Vapour can catch fire if it comes into contact with a hot part of the oven.

For your safety, do not use high-pressure water cleaners or steam jet cleaners.

Children should be kept at a safe distance when the oven is in use.

Frozen foods such as pizzas should be cooked on the big grid. If the baking tray is used, it may become deformed due to the great variation in temperatures.

Do not pour water into the bottom of the oven when it is hot. This could cause damage to the enamel surface.

The oven door must be closed during cooking.

Do not line the bottom of the oven with aluminum foil and do not place any baking trays or tins on it. The aluminum foil blocks the heat, which may result in damage to the enamel surfaces and cause poor cooking results.

Fruit juices will leave stains, which can become permanent on the enamel surfaces of the oven.

When cooking very moist cakes, use the deep pan.

Do not rest bakeware on the open oven door.

Keep children away from the door when opening or closing it as they may bump themselves on the door or catch their fingers in the door.

Do not step, lean, sit or place heavy items on the door.

Do not open the door with unnecessarily strong force.



---

**WARNING:** Do not disconnect the appliance from the main power supply even after the cooking process is completed.

**WARNING:** Do not leave the door open while oven is cooking.

## Auto energy saving function

---

- If no user input is made for a certain time while the appliance is operating, the appliance stops operation and goes to Standby state.
- Light : During cooking process, you can switch off Oven lamp by pressing 'Oven light' button. For energy saving, the oven lighting is switched off a few minutes after cooking program has started.

# Installation

## **⚠ WARNING**

This oven must be installed by a qualified technician. The installer is responsible for connecting the oven to the main power, while observing the relevant safety regulations of your area.

## What's included

Make sure all parts and accessories are included in the product package. If you have a problem with the oven or accessories, contact a local Samsung customer centre or the retailer.

Oven at a glance

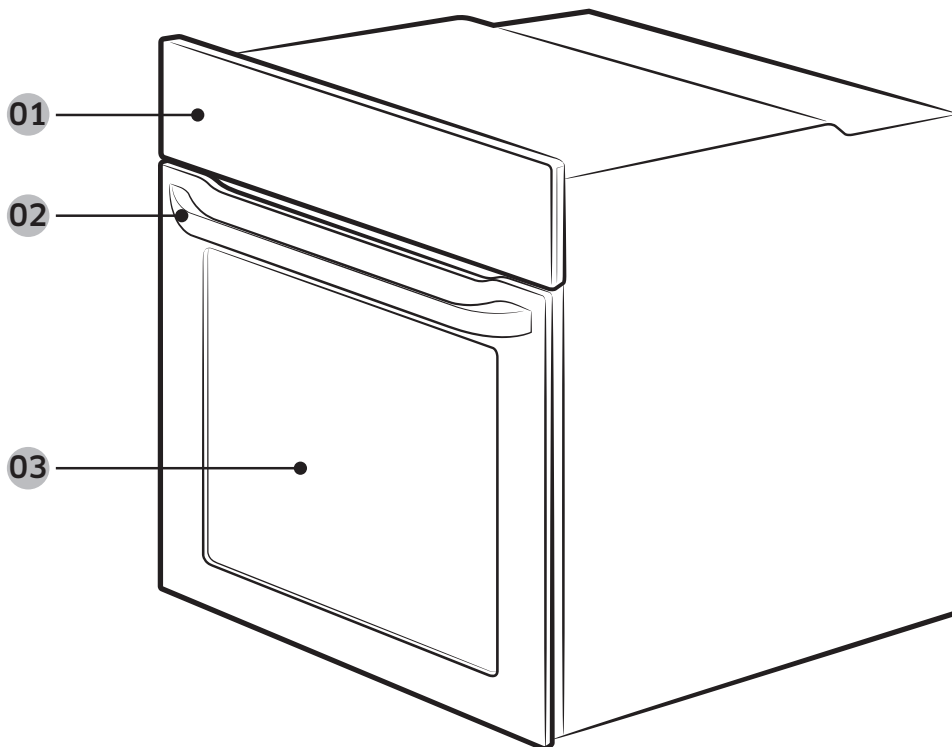

**01** Control panel

**02** Door handle

**03** Door

---

## Accessories

The oven comes with different accessories that help you prepare different types of food.

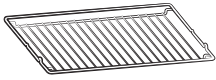

Wire rack



Wire rack insert \*

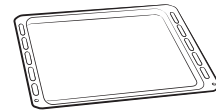

Baking tray \*

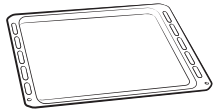

Universal tray \*

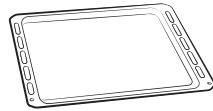

Extra-deep tray \*

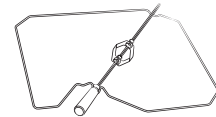

Rotisserie spit \*

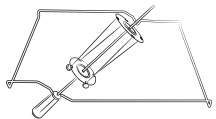

Rotisserie spit and Shashlik \*

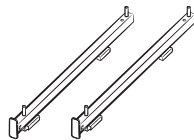

Telescopic rail \*

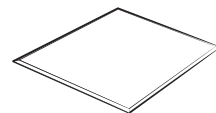

Divider

### NOTE

Availability of accessories with an asterisk (\*) depends on the oven model.

# Installation

## Power connection

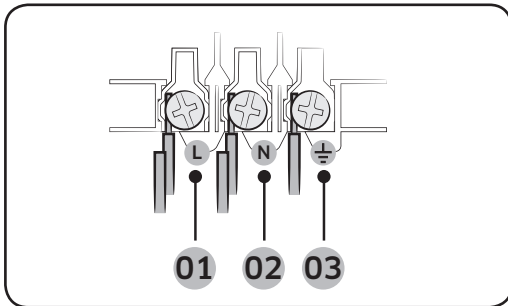

- 01** BROWN or BLACK
- 02** BLUE or WHITE
- 03** YELLOW and GREEN

Plug the oven into an electrical socket. If a plug-type socket is not available due to allowable current limitations, use a multi-pole isolator switch (with at least 3 mm spacing in-between) in order to meet safety regulations. Use a power cord of sufficient length that supports the specification H05 RR-F or H05 VV-F, min. 1.5 ~ 2.5 mm<sup>2</sup>.

Rated current(A)	Minimum cross-sectional area
10 < A ≤ 16	1.5 mm <sup>2</sup>
16 < A ≤ 25	2.5 mm <sup>2</sup>

Check the output specifications on the label attached to the oven.

Open the rear cover of the oven using a screwdriver, and remove the screws on the cord clamp. Then, connect the power lines to the relevant connection terminals.

The (⏏)-terminal is designed for earthing. First connect the yellow and green lines (earthing), which must be longer than the others. If you use a plug-type socket, the plug must remain accessible after the oven is installed.

Samsung is not responsible for accidents caused by missing or faulty earthing.

### **⚠ WARNING**

Do not step on or twist the wires during installation, and keep them away from heat-emitting parts of the oven.

## Cabinet mount

If installing the oven in a built-in cabinet, the cabinet must have its plastic surfaces and adhesive parts resistant up to 90 °C, and adjacent furniture must be resistant up to 75 °C. Samsung is not responsible for damage to furniture from the oven's heat emission. The oven must be properly ventilated. For ventilation, leave a gap of about 50 mm between the lower shelf of the cabinet and the supporting wall. If you install the oven under a cooktop, follow the cooktop's installation instructions.

### Required Dimensions for Installation

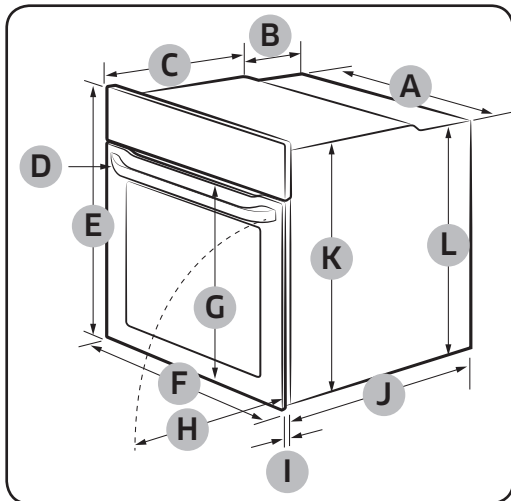

Oven (mm)

<b>A</b>	560	<b>G</b>	Max. 506
<b>B</b>	175	<b>H</b>	Max. 494
<b>C</b>	370	<b>I</b>	21
<b>D</b>	Max. 50	<b>J</b>	545
<b>E</b>	595	<b>K</b>	572
<b>F</b>	595	<b>L</b>	550

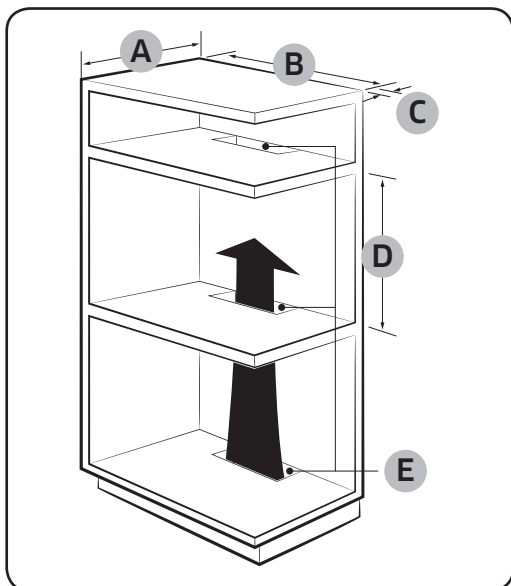

Built-in cabinet (mm)

<b>A</b>	Min. 550
<b>B</b>	Min. 560
<b>C</b>	Min. 50
<b>D</b>	Min. 590 - Max. 600
<b>E</b>	Min 460 x Min. 50

#### NOTE

The built-in cabinet must have vents (E) to ventilate heat and circulate the air.

# Installation

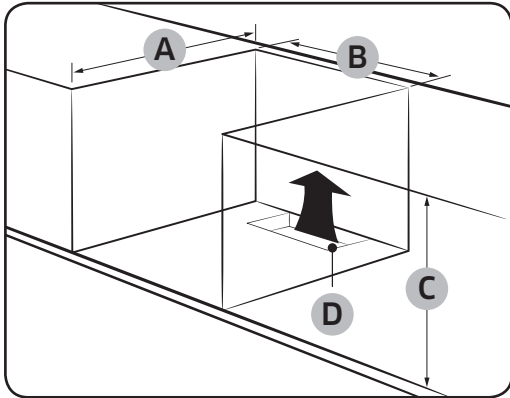

Under-sink cabinet (mm)

<b>A</b>	Min. 550
<b>B</b>	Min. 560
<b>C</b>	Min. 600
<b>D</b>	Min 460 x Min. 50

## NOTE

The built-in cabinet must have vents (D) to ventilate heat and circulate the air.

## Mounting the oven

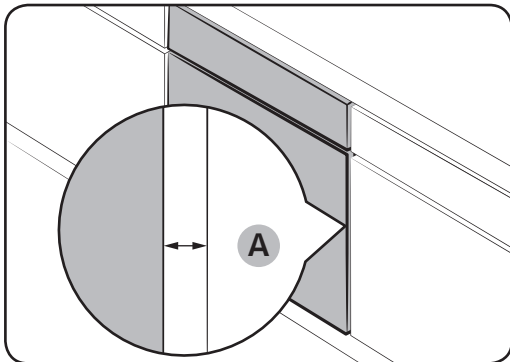

Make sure to leave a gap (**A**) of at least 5 mm between the oven and each side of the cabinet.

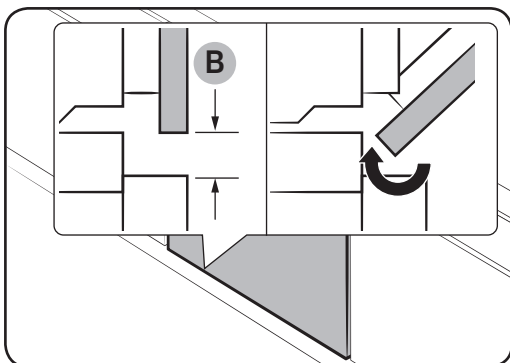

Secure at least 3 mm of gap (**B**) so that the door opens and closes smoothly.

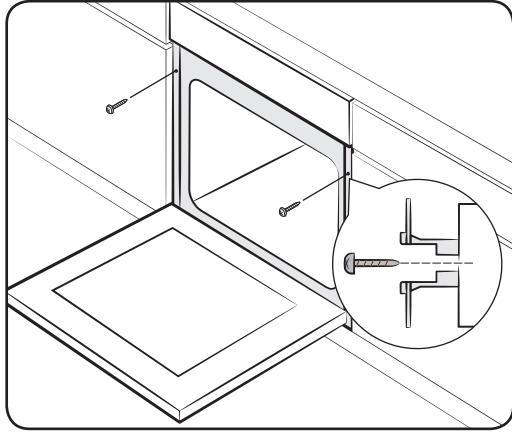

Fit the oven into the cabinet and fix the oven firmly on both sides using 2 screws.

After installation is complete, remove the protective film, tape, and other packing material, and take out the provided accessories from inside the oven. To remove the oven from the cabinet, first disconnect power to the oven and remove 2 screws on both sides of the oven.

**⚠ WARNING**

The oven requires ventilation for normal operation. Do not block the vents under any circumstance.

**📄 NOTE**

The actual appearance of the oven may differ with the model.

# Before you start

## Initial settings

When you power on the oven for the first time, the default time of “12:00” appears on the display where the hour element (“12”) blinks. Follow the steps below to set the current time.

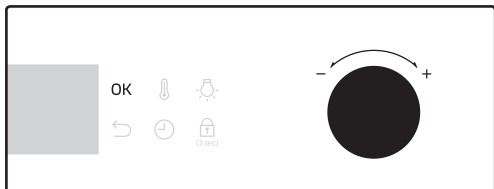

1. With the hour element blinking, turn the value dial (right-sided dial) to set the hour, and then press **OK** to move to the minute element.

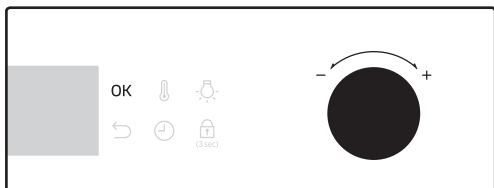

2. With the minute element blinking, turn the value dial to set the minute, and then press **OK**.

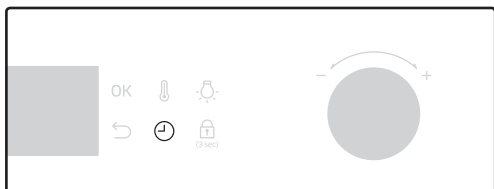

To change the current time after this initial setting, hold down the  button for 3 seconds and follow the above steps.



---

## New oven smell

---

Before using the oven for the first time, clean inside the oven to remove the new oven smell.

1. Remove all accessories from inside the oven.
2. Run the oven with Convection 200 °C or Conventional 200 °C for an hour. This will burn any remaining production substances in the oven.
3. When complete, turn off the oven.

---

## Smart safety mechanism

---

If you open the door while the oven is operating, the oven light turns on and both the fan and the heating elements stop operation. This is to prevent physical injuries such as burns as well as to prevent unnecessary energy loss. When this happens, simply close the door and the oven continues to operate normally because this is not a system failure.

---

## Soft Closing Door (Gentle, Safe, and Silent)

---

The Samsung Built-in Oven features a soft closing door that gently, safely, and silently closes. When closing the door, the specially designed hinges catch the door a few centimetres before the final position. This is the perfect touch for added comfort, allowing the door to be closed silently and gently. (Availability of this feature depends on the oven model.)

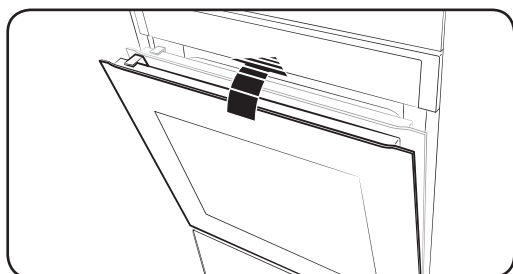

The door starts to be closed softly at about 15 degrees and completely closed within approx. 5 seconds.



# Before you start

## Accessories

For first time use, clean the accessories thoroughly with warm water, detergent and a soft clean cloth.

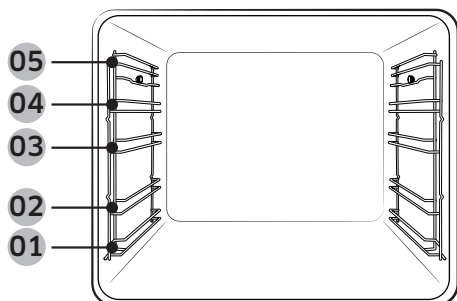

**01** Level 1

**02** Level 2

**03** Level 3

**04** Level 4

**05** Level 5

- Insert the accessory to the correct position inside of the oven.
- Allow at least a 1 cm space from the accessory and the bottom of the oven, and from any other accessory.
- Take caution in removing cookware and/or accessories out of the oven. Hot meals or accessories can cause burns.
- The accessories may be deformed while they are gaining heat. Once they have cooled down, they will recover their original appearance and performance.

### Basic use

For better cooking experience, familiarise yourself with how to use each accessory.

Wire rack	The wire rack is designed for grilling and roasting. Insert the wire rack into position with the protruding parts (stoppers on both sides) towards the front
Wire rack insert *	The wire rack insert is used with the tray, and prevents liquid from dropping onto the bottom of the oven.
Baking tray *	The baking tray (depth: 20 mm) is used to bake cakes, cookies, and other pastries. Put the slanted side to the front.
Universal tray *	The universal tray (depth : 30 mm) is used for cooking and roasting. Use the wire-tray insert to prevent liquid from dropping onto the bottom of the oven. Put the slanted side to the front.
Extra-deep tray *	The extra-deep tray (depth: 50 mm) is used for roasting with or without the wire-tray insert. Put the slanted side to the front.
Rotisserie spit *	The rotisserie spit is used for grilling food such as chicken. Use the rotisserie spit only in Single mode at level 4 where the spit adapter is available. Unscrew the spit handle to remove while grilling.

<b>Rotisserie spit and Shashlik *</b>	<p>Put the tray at rack position 1 to collect cooking juices, or on the bottom of the oven for a large serving of meat. It is recommended to use the spit accessories for meat under 1.5 kg.</p> <ol style="list-style-type: none"> <li><b>1.</b> Insert the spit into the meat. To help insert the spit, screw the spit handle toward the blunt end.</li> <li><b>2.</b> Put parboiled potatoes and vegetables around the meat.</li> <li><b>3.</b> Put the cradle at the middle tray position with the “V” shape to the front. Rest the spit onto the cradle with the pointed end backward and gently push until the tip of the spit enters the turning mechanism at the back of the oven. The blunt end of the spit must rest on the “V” shape. (The spit has two lugs which should be nearest to the oven door so to stop the spit going forward, the lugs also act as a grip for the handle.)</li> <li><b>4.</b> Unscrew the handle before cooking.</li> <li><b>5.</b> After cooking, screw the handle back to help remove the spit from the cradle.</li> </ol>
<b>Telescopic rails *</b>	<p>Use the telescopic rail plate to insert the tray as follows:</p> <ol style="list-style-type: none"> <li><b>1.</b> Stretch the rail plate out from the oven.</li> <li><b>2.</b> Put the tray on the rail plate and slide the rail plate into the oven.</li> <li><b>3.</b> Close the oven door.</li> </ol>
<b>Divider</b>	<p>The divider is designed to separate the oven in two compartments. Use the divider with Dual cook mode.</p>

Before you start

 **NOTE**

Availability of accessories with an asterisk (\*) depends on the oven model.

# Before you start

---

## Dual cook mode

---

You can use both the upper and lower compartments to cook two different recipes, or simply choose one compartment to cook with.

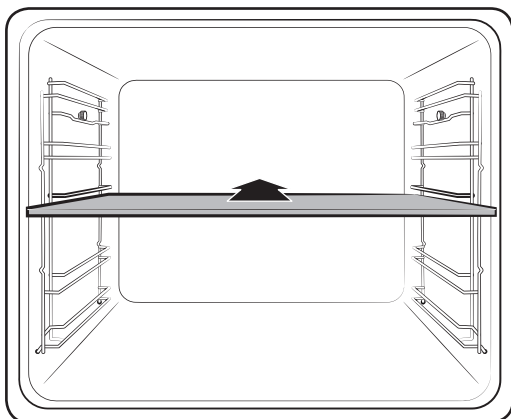

Insert the divider in level 3 to separate the cooking chamber in two compartments. The oven senses the divider and activates the upper compartment by default.

### **NOTE**

Availability of Dual cook mode depends on the recipe. For more information, see the Cooking Guide section in this manual.

# Operations

## Control panel

The front panel comes in a wide range of materials and colours. For improved quality, the actual appearance of the oven is subject to change without notice.

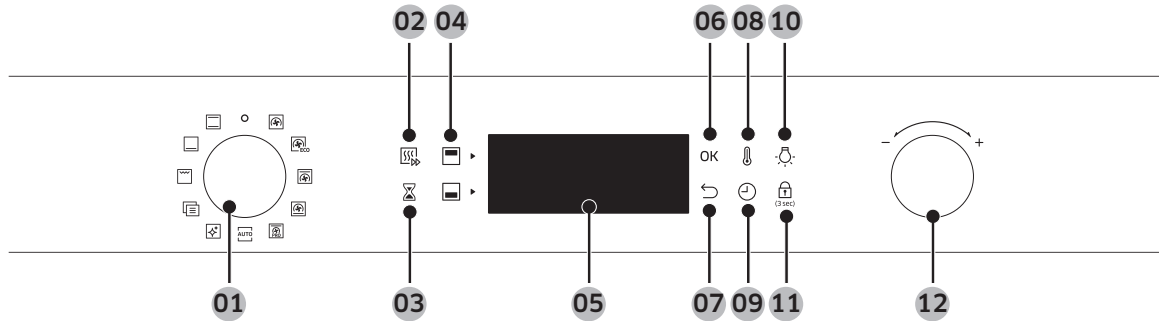

<b>01</b> Mode selector	Turn to select a cooking mode or function.
<b>02</b> Fast preheat	Fast Preheat heats the oven fast to a set temperature. <ul style="list-style-type: none"> <li>Press to toggle on or off the Fast Preheat option.</li> <li>Available only with Single mode.</li> <li>Disabled for temperatures set at less than 100 °C.</li> </ul>
<b>03</b> Timer	Timer helps you check the time or operating duration while cooking.
<b>04</b> Upper/Lower Compartment	The indicators turn on when the divider is inserted. You can choose Upper or Lower for your recipe.
<b>05</b> Display	Shows necessary information of selected modes or settings.
<b>06</b> OK	Press to confirm your settings.
<b>07</b> Back	Cancel current settings, and return to the main screen.
<b>08</b> Temperature	Use to set the temperature.
<b>09</b> Cooking time	Press to set the cooking time.
<b>10</b> Oven light	Press to turn the internal light on or off. The oven light turns on automatically when the door is open or when the oven operation starts. And it turns off automatically after a certain period of inactivity in order to save power.
<b>11</b> Child lock	To prevent accidents, Child lock disables all controls. But you can switch off by turning the mode selector to off. Hold down for 3 seconds to activate, or hold down for 3 seconds again to deactivate the lock on the control panel.

# Operations

## 12 Value dial

Use the value dial to:

- Set the cooking time or temperature.
- Choose a sub item of top-level menus: Cleaning, Auto cook, Special function, or Grill.
- Choose a serving size for Auto Cook programmes.

### NOTE

Tapping on the display while wearing plastic or oven gloves may not operate properly.

## Common settings

It is common to change the default temperature and/or cooking time across all cooking modes. Follow the steps below to adjust the temperature and/or cooking time for the selected cooking mode.

### Temperature

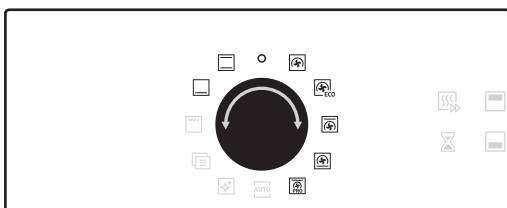

1. Turn the mode selector to choose a mode or function. The default temperature of each selection appears.

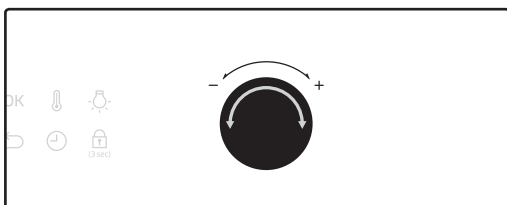

2. Turn the value dial to set a desired temperature.

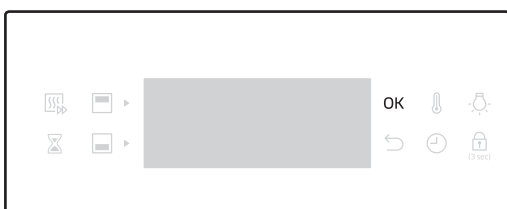



3. Press **OK** to confirm your changes.

### NOTE

- If you do not make any further settings within a few seconds, the oven starts cooking automatically with the default settings.
- To change the set temperature, press the  button and follow the above steps.
- The exact temperature inside the oven can be measured with authorized thermometer and method defined by an authorized institution. Using other thermometers may cause a measuring error.

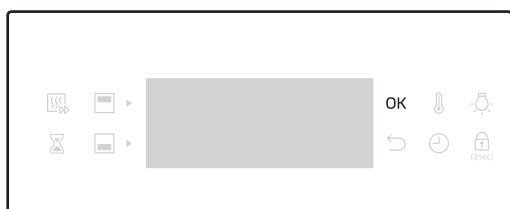
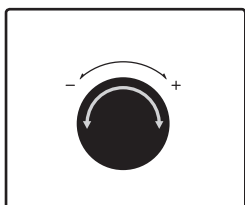
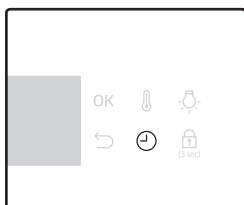
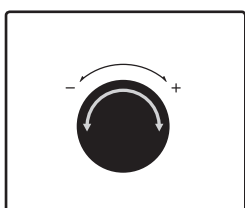
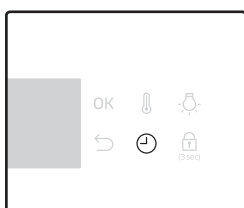
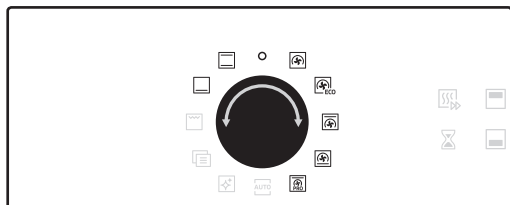
## Cooking time



1. Turn the mode selector to choose a mode or function.
2. Press the  button, and then turn the value dial to set a desired time up to 23 hours 59 minutes.
3. Optionally, you can delay the end time of your cooking to a desired point. Press the  button, and use the value dial to set an end point. See **Delay End** for more information.
4. Press **OK** to confirm your changes.

### NOTE

- You can cook without setting the cooking time if you want to. In this case, the oven starts cooking at set temperatures without time information, and you must stop the oven manually when cooking is complete.
- To change the set cooking time, press  button and follow the above steps.

# Operations

## End time

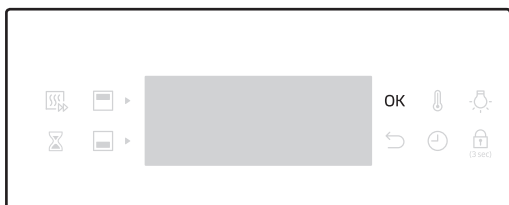
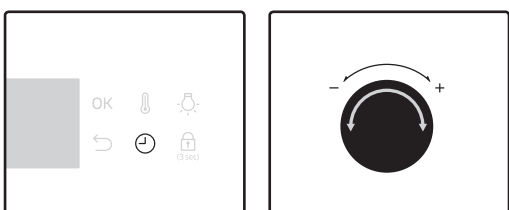

1. Turn the mode selector to choose a mode or function.
2. Press  twice, and turn the value dial to set a desired end time.
3. Press **OK** to confirm your changes.

### NOTE

- You can cook without setting the end time if you want to. In this case, the oven starts cooking at set temperatures without time information, and you must stop the oven manually when cooking is complete.
- To change the end time, press  twice, and follow the above steps.



## Delay End

Delay End is designed to make cooking more convenient.

### Case 1

Suppose you select a one-hour recipe at 2:00 PM and you want the oven to finish cooking at 6:00 PM. To set the end time, change the Ready At time to 6:00 PM. The oven will start cooking at 5:00 PM and end at 6:00 PM as you set.

Current time: 2 pm                      Set cooking time: 1 hour                      Set Delay End time: 6 pm

The oven will start cooking at 5:00 PM and end at 6:00 PM automatically.

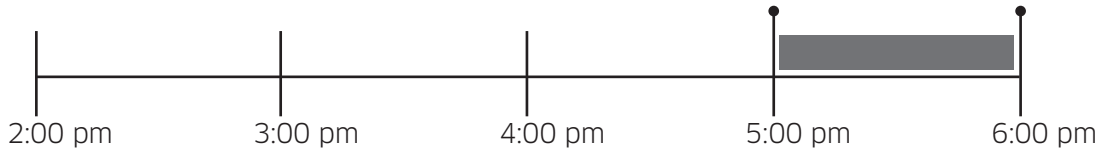

### Case 2

Current time: 2 pm                      Set cooking time: 2 hour                      Set Delay End time: 5 pm

The oven will start cooking at 3:00 PM and end at 5:00 PM automatically.

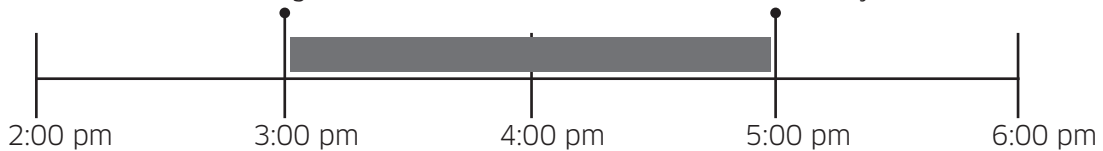

### ⚠ CAUTION

- Delay End is not available in Dual cook mode.
- Do not keep cooked food in the oven too long. The food may spoil.



# Operations

## To clear the cooking time

You can clear the cooking time. This is useful if you want to stop the oven manually at any time during the process.

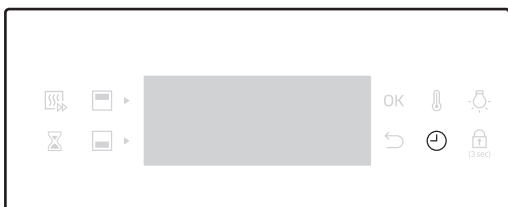

1. While the oven is cooking, press the  button to display the default cooking time.

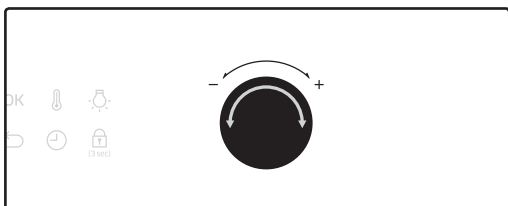

2. Turn the value dial to set the cooking time to "00:00". Alternatively, simply press .

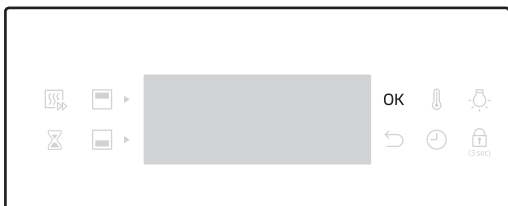

3. Press **OK**.

### NOTE

In Dual cook mode, you must first select the upper or lower compartment that you want to clear the cooking time for.

## To clear the end time

You can clear the end time. This is useful if you want to stop the oven manually at any time during the process.

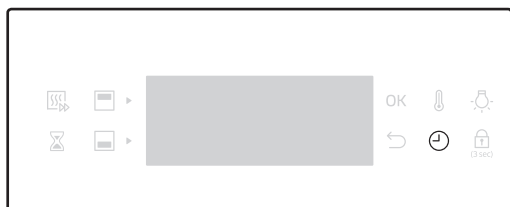

1. While the oven is cooking, press  $\ominus$  twice to display the set end time.

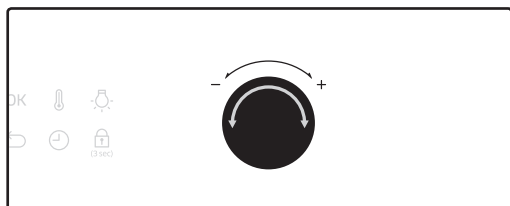

2. Turn the value dial to set the end time to the current time. Alternatively, simply press  $\leftarrow$ .

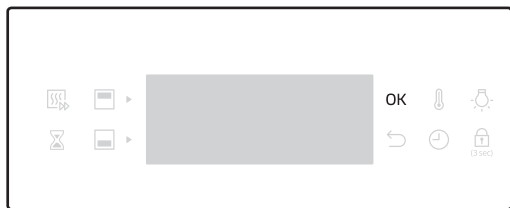

3. Press **OK**.



### NOTE

In Dual cook mode, you must first select the upper or lower compartment that you want to clear the end time for.

# Operations

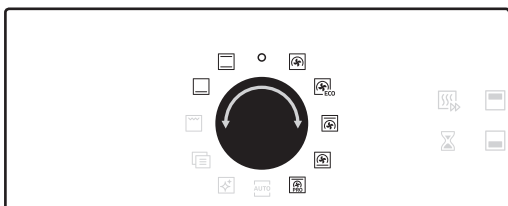
## Cooking modes (except for Grill)



1. Turn the mode selector to select an cooking mode.
2. Set the cooking time and/or temperature if necessary. See the **Common Settings** section for details.
3. Optionally, you can fast preheat the oven. To do this, press the  button, and set the target temperature. The corresponding indicator  appears on the display.

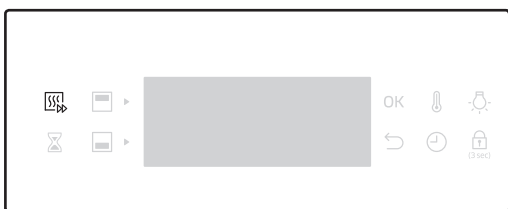

The oven starts preheating until the internal temperature reaches the target temperature. When preheating is complete, the indicator disappears with a beep. Preheating is recommended for all cooking modes unless otherwise specified in the cooking guide.



### NOTE

You can change the cooking time and/or temperature during cooking.

## Dual cook mode

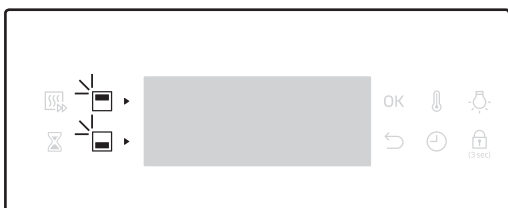
You can use the provided divider to separate the cooking chamber in the upper and lower compartments. This allows users to enable two different cooking modes simultaneously, or to simply choose one compartment to cook with.



1. Insert the Divider in level 3 to separate the cooking chamber in two compartments. The oven senses the divider, and by default, activates the upper compartment with the / buttons lit.

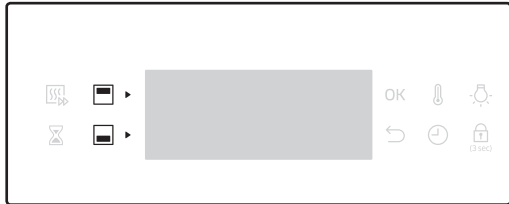

2. Press to select the upper compartment, or press to select the lower compartment.

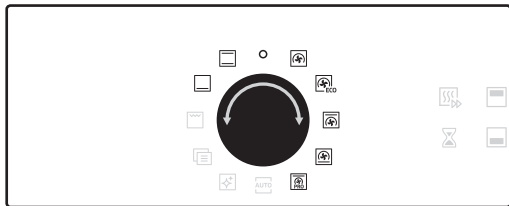

3. Turn the mode selector to select an cooking mode.  
 4. Set the cooking time and/or temperature if necessary. See the **Common Settings** section for details.

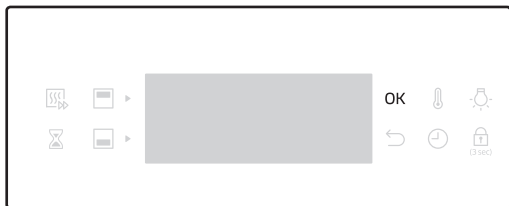

5. When done, press **OK**.

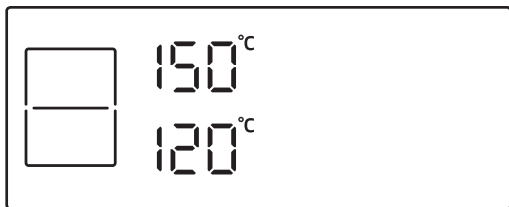

The oven starts preheating until the internal temperature reaches the target temperature. Preheating is recommended for all cooking modes unless otherwise specified in the cooking guide.

**NOTE**

Availability of Dual cook mode depends on the cooking mode. For more information, see the **Cooking Guide** section in this manual.

**Cooking modes (except for Grill)**

Fast preheat is available only with applicable cooking modes and temperature ranges.

Mode		Temperature range (°C)			Suggested temperature (°C)
		Single	Dual		
			Upper	Lower	
	Convection	30-275	40-250	40-250	170
		The rear heating element generates heat, which is evenly distributed by the convection fan. Use this mode for baking and roasting on different levels at the same time.			

# Operations

Mode		Temperature range (°C)			Suggested temperature (°C)
		Single	Dual		
			Upper	Lower	
	Conventional	30-275	-	-	200
		The heat is generated from the top and bottom heating elements. This function should be used for standard baking and roasting for most types of dishes.			
	Top heat + Convection	40-275	40-250	-	190
		The top heating element generates heat, which is evenly distributed by the convection fan. Use this mode for roasting that requires a crispy top (for example, meat or lasagne).			
	Bottom heat + convection	40-275	-	40-250	190
		The bottom heating element generates heat, which is evenly distributed by the convection fan. Use this mode for pizza, bread, or cake.			
	Bottom heat	100-230	-	40-250	190
		The bottom heating element generates heat. Use this mode at the end of baking or cooking to brown the bottoms of a quiche or pizza.			
	Pro-Roasting	80-200	-	-	160
		Pro-Roasting runs an automatic pre-heating cycle until the oven temperature reaches 220 °C. Then, the top heating element and the convection fan start operating to sear food such as meat. After searing, the meat will be cooked at low temperatures. Use this mode for beef, poultry, or fish.			
	Eco Convection	30-275	-	-	170
		Eco Convection uses the optimized heating system to save energy while cooking. The cooking times slightly increases, but the cooking results remain the same. Note that this mode does not require preheating.			
		<p> <b>NOTE</b></p> <p>ECO Convection mode of heating used to determine the energy efficiency class is in accordance with EN60350-1</p>			

## Cooking modes (Grill)



1. Turn the mode selector to select .

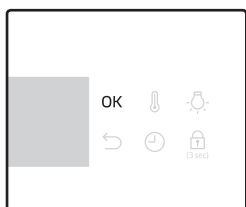
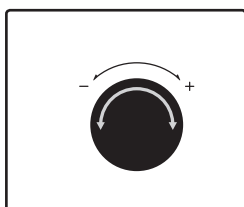

2. Use the value dial to select a **Large grill (G 1)** or **Eco grill (G 2)**, and then press **OK**.

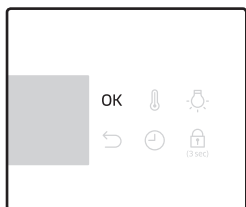
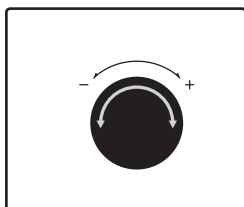

3. Use the value dial to set the temperature, and then press **OK**.

### Dual cook mode

Grilling with Dual cook mode is useful for small serving sizes to save power. By default, only the Large grill option in the upper compartment is available because the oven uses only the top heating element.

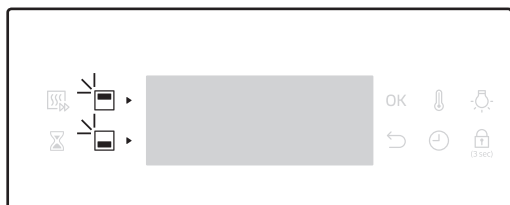

1. Insert the divider in level 3 to activate Dual cook mode.



2. Turn the mode selector to select . By default, only **Large grill (G 1)** is selected automatically.

# Operations

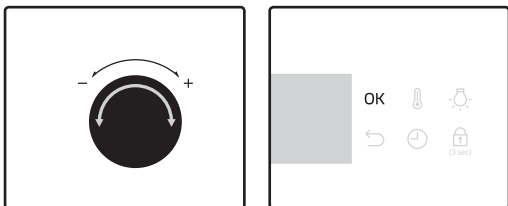

- Use the value dial to set the temperature, and then press **OK**.

## Cooking modes (Grill)

Mode		Temperature range (°C)			Suggested temperature (°C)
		Single	Dual		
			Upper	Lower	
G 1	Large grill	100-300	40-250	-	240
		The large-area grill emits heat. Use this mode for browning the tops of food (for example, meat, lasagne, or gratin).			
G 2	Eco grill	100-300	-	-	240
		The small-area grill emits heat. Use this mode for food that requires less heat, such as fish and filled baguettes.			

---

## Dual cook mode temperature setting range

---

You can use both the upper and lower compartments simultaneously for different cooking operations.

In Dual Cook mode, the temperature range of one compartment is affected by the temperature settings of the other compartment. For instance, broiling in the upper compartment will be limited by the operation in the lower compartment in terms of cooking temperatures. However, either compartment limits its temperature settings between minimum 40 and maximum 250.

If Upper is set to (°C)	Lower compartment is limited to (°C)	
	Minimum	Maximum
40	40	45
60	50	75
80	65	105
100	80	135
120	90	160
140	105	190
160	120	220
180	135	250
200	145	250
220	160	250
250	170	250

# Operations

---

If Lower is set to (°C)	Upper compartment is limited to (°C)	
	Minimum	Maximum
40	40	45
60	50	75
80	65	105
100	80	135
120	90	160
140	105	190
160	120	220
180	135	250
200	145	250
220	160	250
250	170	250

## To stop cooking





While cooking is in process, turn the mode selector to “○”. The oven turns off in a few seconds. This is because, to avoid accepting incorrect commands by users, the oven waits a few seconds so that they can correct their selection.

## To stop cooking for an individual compartment

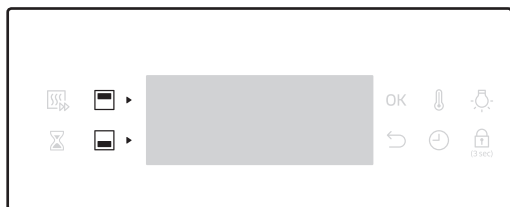
Follow these instructions to stop cooking in Dual cook mode.



1. Press  to select the upper compartment, or press  to select the lower compartment.

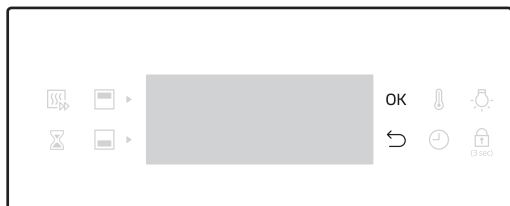



2. Press , and then press **OK**. The oven stops cooking with the selected compartment.

# Operations

## Special function

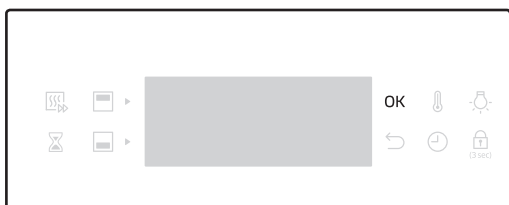
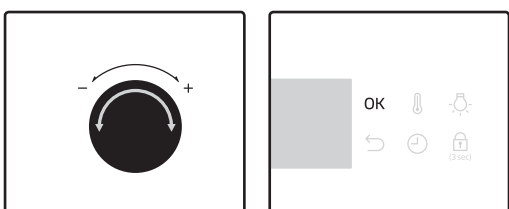
Add special or additional functions to improve your cooking experience. Special functions are not enabled in Dual cook mode.



1. Turn the mode selector to select .
2. Turn the value dial to select a function, and then press **OK**. The default temperature appears.
3. Set the cooking time and/or temperature if necessary. See the **Common Settings** section for details.
4. Press **OK** to start the function.

	Mode	Temperature range (°C)	Suggested temperature (°C)	Instructions
F 1	Keep warm	40-100	80	Use this only for keeping foods warm that have just been cooked.
F 2	Plate warm	30-80	60	Use this for warming dishes or ovenware.

## Auto cook

For inexperienced cooks, the oven offers a total of 50 auto cooking recipes. Take advantage of this feature to save you time or shorten your learning curve. The cooking time and temperature will be adjusted according to the selected recipe.

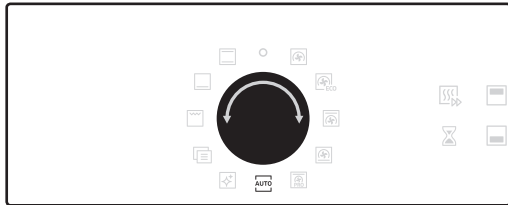

1. Turn the mode selector to select **AUTO**.

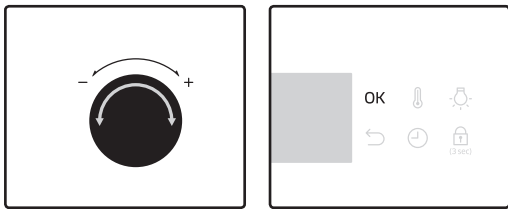

2. Turn the value dial to select a programme, and then press **OK**.

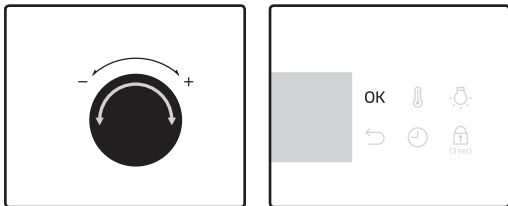

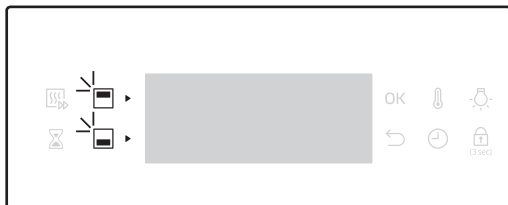

3. Turn the value dial to select a serving size. The weight range depends on the programme.
4. Press **OK** to start cooking.

## Dual cook mode

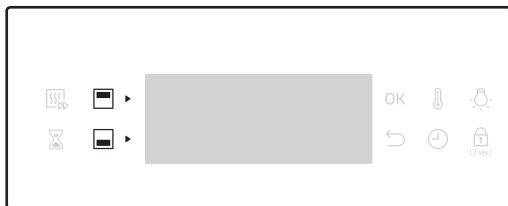

1. Insert the divider in level 3 to activate Dual cook mode. The upper compartment defaults to be active.



2. Press  to select the upper compartment, or press  to select the lower compartment.



## Cleaning

Two cleaning modes are available for you. This function saves you time by removing the need for regular manual cleaning.

Function		Instructions
C 1	Steam cleaning	This is useful for cleaning light soiling with steaming.
C 2	Pyro cleaning	Pyrolytic features high temperature thermal cleaning. It burns off oily leftovers to facilitate manual cleaning.

### Steam cleaning

This is useful for cleaning light soiling with steaming.

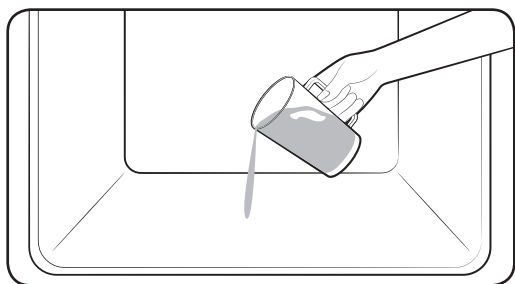

1. Pour 400 ml ( $\frac{3}{4}$  pint) of water onto the bottom of the oven and close the oven door.

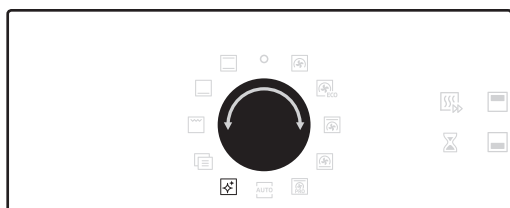

2. Turn the mode selector to select .

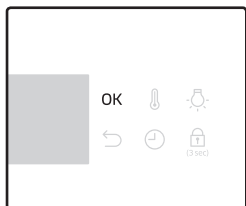
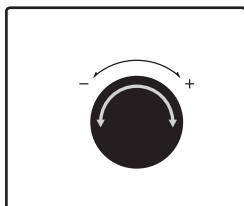

3. Turn the value dial to select Steam cleaning (C 1), and then press **OK** to start cleaning.

# Operations

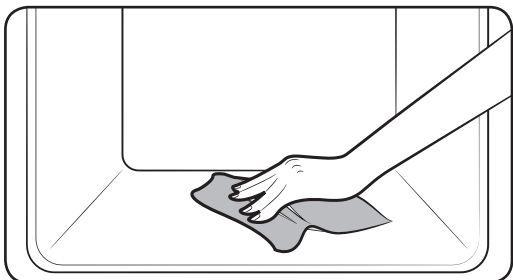

4. Use a dry cloth to clean inside the oven.

## **⚠ WARNING**

- Do not open the door before the cycle is complete. The water inside the oven is very hot, and it can cause a burn.

## **📄 NOTE**

- If the oven is heavily soiled with grease, for example, after roasting or grilling, it is recommended to remove stubborn soils manually using a cleaning agent before activating Steam cleaning.
- Leave the oven door ajar when the cycle is complete. This is to allow the interior enamel surface to dry thoroughly.
- If the oven is hot inside, cleaning is not activated. Wait until the oven cools down, and try again.
- Do not pour water onto the bottom by force. Do it gently. Otherwise, the water overflows to the front.

## Pyro cleaning

Pyrolytic features high temperature thermal cleaning. It burns off oily leftovers to facilitate manual cleaning.

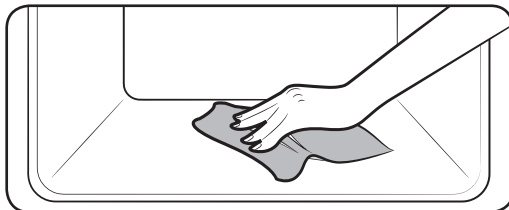
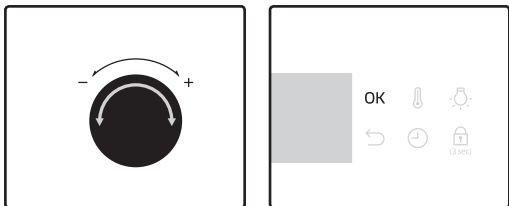
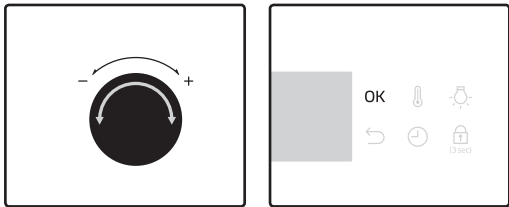
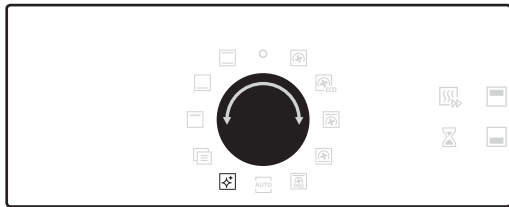

1. Remove all accessories including the side runners, and wipe out large pieces of impurities manually from inside the oven. Otherwise, they may cause flames during the cleaning cycle, resulting in fire.
2. Turn the mode selector to select .
3. Turn the value dial to select Pyro cleaning (C 2), and then press **OK**.
4. Turn the value dial to select a cleaning time from 3 levels: 1 hr 50 min, 2 hr 10 min, and 2 hr 30 min.
5. Press **OK** to start cleaning.
6. When complete, wait until the oven cools down, and then wipe the door along its edges using a wet cloth.

### CAUTION

- Do not touch the oven because the oven becomes very hot during the cycle.
- To avoid accidents, keep children away from the oven.
- After the cycle is complete, do not power off while the cooling fan is operating to cool the oven down.

### NOTE

- Once the cycle starts, the oven becomes hot inside. Then, the door will be locked for safety. When the cycle is complete and the oven cools down, the door will be unlocked.
- Make sure you empty the oven before cleaning. Accessories can be deformed due to high temperatures inside the oven.

# Operations

## Timer

Timer helps you check the time or operating duration while cooking.

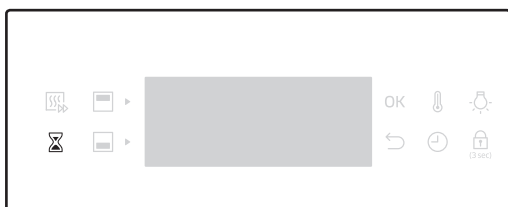

1. Press .

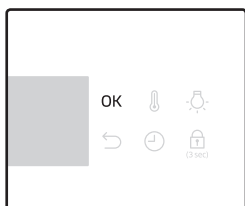
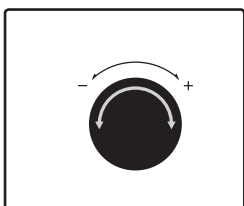

2. Turn the value dial to set the time, and then press **OK**.

### NOTE

- When the time has elapsed, the oven beeps with a blinking message of "00:00" on the display.
- You can change the timer settings at any time.

## Sound On/Off

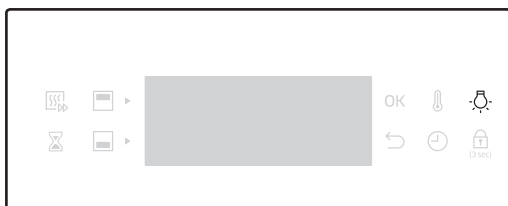

- To mute the sound, tap and hold down Oven Light for 3 seconds.
- To unmute the sound, tap and hold down again for 3 seconds.

# Cooking Smart

## Manual cooking

### WARNING on acrylamide

Acrylamide produced while baking starch-contained food such as potato chips, French fries, and bread may cause health problems. It is recommended to cook these foods at low temperatures and avoid overcooking, heavy crisping, or burning.

### Accessory tips





Your oven comes with a different number or kind of accessories. You may find that some accessories are missing from the table below. However, even if you are not provided with the exact accessories specified in this cooking guide, you can follow along with what you already have, and achieve the same results.

### NOTE

- Pre-heating is recommended for all cooking modes unless otherwise specified in the cooking guide.
- When using Eco Grill, put food in the centre of the accessory tray.
- The Baking tray and the Universal tray are interchangeable.
- When cooking oily foods, it is recommended to put a tray under the Wire rack to collect oil residue. If you are provided with the Wire rack insert, you can use it together with the tray.
- If you are provided with the Universal tray or Extra deep tray, or both, it is better to use whichever is deeper for cooking oily foods.

### Baking

We recommend to preheat the oven for best results.

Food	Accessory	Level	Type of heating	Temp. (°C)	Time (min.)
Sponge cake	Wire rack, Ø 25-26 cm tin	2		160-170	35-40
Marble cake	Wire rack, Gugelhopf tin	3		175-185	50-60
Tart	Wire rack, Ø 20 cm tart tin	3		190-200	50-60
Yeast cake on tray with fruits and crumbles	Universal tray	2		160-180	40-50

# Cooking Smart

Food	Accessory	Level	Type of heating	Temp. (°C)	Time (min.)
Fruit crumble	Wire rack, 22-24 cm oven dish	3		170-180	25-30
Scones	Universal tray	3		180-190	30-35
Lasagne	Wire rack, 22-24 cm oven dish	3		190-200	25-30
Meringues	Universal tray	3		80-100	100-150
Soufflé	Wire rack, soufflé cups	3		170-180	20-25
Apple yeast tray cake	Universal tray	3		150-170	60-70
Homemade pizza, 1-1.2kg	Universal tray	2		190-210	10-15
Frozen puff pastry, filled	Universal tray	2		180-200	20-25
Quiche	Wire rack, 22-24 cm oven dish	2		180-190	25-35
Apple pie	Wire rack, Ø 20 cm tin	2		160-170	65-75
Chilled pizza	Universal tray	3		180-200	5-10

## Roasting

Food	Accessory	Level	Type of heating	Temp. (°C)	Time (min.)
<b>Meat(Beef/Pork/Lamb)</b>					
Sirloin of beef, 1 kg	Wire rack + Universal tray	3 1		160-180	50-70
Boned loin of veal, 1.5 kg	Wire rack + Universal tray	3 1		160-180	90-120









Food	Accessory	Level	Type of heating	Temp. (°C)	Time (min.)
Pork roast, 1 kg	Wire rack + Universal tray	3 1		200-210	50-60
Joint of pork, 1 kg	Wire rack + Universal tray	3 1		160-180	100-120
Leg of lamb on the bone, 1 kg	Wire rack + Universal tray	3 1		170-180	100-120
<b>Poultry(Chicken/Duck/Turkey)</b>					
Chicken, Whole, 1.2 kg*	Wire rack + Universal tray (to catch drippings)	3 1		205	80-100*
Chicken pieces	Wire rack + Universal tray	3 1		200-220	25-35
Duck breast	Wire rack + Universal tray	3 1		180-200	20-30
Small turkey, whole, 5 kg	Wire rack + Universal tray	3 1		180-200	120-150
<b>Vegetables</b>					
Vegetables, 0.5 kg	Universal tray	3		220-230	15-20
Baked potato halves, 0.5 kg	Universal tray	3		200	45-50
<b>Fish</b>					
Fish fillet, baked	Wire rack + Universal tray	3 1		200-230	10-15
Roast fish	Wire rack + Universal tray	3 1		180-200	30-40

\* Turnover after half of time.

# Cooking Smart



## Grilling







We recommend preheat the oven using large grill mode. Turn over after half of time.

Food	Accessory	Level	Type of heating	Temp. (°C)	Time (min.)
<b>Bread</b>					
Toast	Wire rack	5		270-300	2-4
Cheese toast	Universal tray	4		200	4-8
<b>Beef</b>					
Steak*	Wire rack + Universal tray	4 1		240-250	15-20
Burgers*	Wire rack + Universal tray	4 1		250-270	13-18
<b>Pork</b>					
Pork chops	Wire rack + Universal tray	4 1		250-270	15-20
Sausages	Wire rack + Universal tray	4 1		260-270	10-15
<b>Poultry</b>					
Chicken, breast	Wire rack + Universal tray	4 1		230-240	30-35
Chicken, drumstick	Wire rack + Universal tray	4 1		230-240	25-30

\* Turnover after  $\frac{2}{3}$  of the cooking time.

## Frozen ready-meal

Food	Accessory	Level	Type of heating	Temp. (°C)	Time (min.)
Frozen pizza, 0.4-0.6 kg	Wire rack	3		200-220	15-25
Frozen lasagne	Wire rack	3		180-200	45-50

Food	Accessory	Level	Type of heating	Temp. (°C)	Time (min.)
Frozen oven chips	Universal tray	3		220-225	20-25
Frozen Croquettes	Universal tray	3		220-230	25-30
Frozen oven camembert	Wire rack	3		190-200	10-15
Frozen baguettes with topping	Wire rack + Universal tray	3 1		190-200	10-15
Frozen fish fingers	Wire rack + Universal tray	3 1		190-200	15-25
Frozen fish burger	Wire rack	3		180-200	20-35

### Pro-Roasting

This mode includes an automatic heating-up cycle up to 220 °C. The top heater and the convection fan are operating during the process of searing the meat. After this stage the food is cooked gently by the low temperature of pre-selection. This process is done while the top and the bottom heaters are operating. This mode is suitable for meat roasts and poultry.

Food	Accessory	Level	Temp. (°C)	Time (hrs.)
Roast beef	Wire rack + Universal tray	3 1	80-100	3-4
Pork roast	Wire rack + Universal tray	3 1	80-100	4-5
Lamb roast	Wire rack + Universal tray	3 1	80-100	3-4
Duck breast	Wire rack + Universal tray	3 1	70-90	2-3

# Cooking Smart

## ECO convection

This mode uses the optimized heating system so that you save the energy during cooking your dishes. The times of this category are suggested to not be preheated before cooking for saving more energy.

Food	Accessory	Level	Temp. (°C)	Time (min.)
Meringues, 0.2-0.3 kg	Universal tray	2	90-100	100-140
Fruit crumble, 0.8-1.2kg	Wire rack	2	160-180	60-80
Jacket potatoes, 0.4-0.8 kg	Universal tray	2	190-200	70-80
Sausages, 0.3-0.5 kg	Wire rack + Universal tray	3 1	160-180	20-30
Frozen oven chips, 0.3-0.5 kg	Universal tray	3	180-200	25-35
Frozen potato wedges, 0.3-0.5 kg	Universal tray	3	190-210	25-35
Fish fillets, baked, 0.4-0.8 kg	Wire rack + Universal tray	3 1	200-220	30-40
Crispy fish fillets, breaded, 0.4-0.8 kg	Wire rack + Universal tray	3 1	200-220	30-45
Roast sirloin of beef, 0.8-1.2 kg	Wire rack + Universal tray	2 1	180-200	65-75
Roast vegetables, 0.4-0.6 kg	Universal tray	3	200-220	25-35

## Dual cook

Before using dual cook function insert the divider into the oven. We recommend preheat the oven for best results.

The following table presents 5 dual cook guides we recommended for cooking, roasting and baking. Using dual cook function, you will be able to cook your main dish & side dish or main dish & dessert simultaneously.

- Using dual cook function, preheating time can be extended.

No	Cavity	Food	Accessory	Level	Type of heating	Temp. (°C)	Time (min.)
1	Upper	Sponge cake	Wire rack, Ø 25-26 cm tin	4		160-170	40-45
	Lower	Homemade pizza, 1.0-1.2 kg	Universal tray	1		190-210	13-18
2	Upper	Roast vegetables, 0.4-0.8 kg	Universal tray	4		220-230	13-18
	Lower	Apple pie	Wire rack, Ø 20 cm tin	1		160-170	70-80
3	Upper	Pita bread	Universal tray	4		230-240	13-18
	Lower	Potato gratin, 1.0-1.5 kg	Wire rack, 22-24cm oven dish	1		180-190	45-50
4	Upper	Chicken, drumstick	Wire rack + universal tray	4 4		230-250	30-35
	Lower	Lasagne, 1.0-1.5 kg	Wire rack, 22-24cm oven dish	1		190-200	30-35
5	Upper	Fish fillet, baked	Wire rack + Universal tray	4 4		210-230	15-20
	Lower	Apple puff pastry	Universal tray	1		170-180	25-30

# Cooking Smart

## Auto cook programmes

### Single cook

The following table presents 40 auto programmes for cooking, roasting and baking. It contains its quantities, weight ranges and appropriate recommendations. Cooking modes and times have been pre-programmed for your convenience. You will find some recipes for the auto programmes in your instruction book.

Auto cook programmes 1 to 19, 38 and 39 include preheating and display the preheating progress. Please put the food in the oven after preheating beep.

### WARNING

Always use oven gloves while taking out food.

Code	Food	Weight (kg)	Accessory	Level
A 1	Potato gratin	1.0-1.5	Wire rack	3
		Prepare fresh potato gratin using an ovenproof dish, 22-24 cm. Start programme, after preheating beep sounds, put dish in the centre of rack.		
A 2	Vegetable gratin	0.8-1.2	Wire rack	3
		Prepare fresh vegetable gratin using an ovenproof dish, 22-24 cm. Start programme, after preheating beep sounds, put dish in the centre of rack.		
A 3	Pasta bake	1.2-1.5	Wire rack	3
		Prepare pasta gratin using 22-24 cm ovenproof dish. Start programme, after preheating beep sounds, put dish in the centre of rack.		
A 4	Lasagne	1.0-1.5	Wire rack	3
		Prepare homemade lasagne using 22-24 cm ovenproof dish. Start programme, after preheating beep sounds, put dish in the centre of rack.		
A 5	Ratatouille	1.2-1.5	Wire rack	3
		Put ingredients for Ratatouille in casserole dish with lid. Start programme, after preheating beep sounds, put dish in the centre of rack. Bake covered. Stir before serving.		

Code	Food	Weight (kg)	Accessory	Level
A 6	Apple pie	1.2-1.4	Wire rack	2
		Prepare apple pie using a 24-26 cm round metal baking tin. Start programme, after preheating beep sounds, put tin in the centre of rack.		
A 7	Croissants	0.3-0.4	Universal tray	3
		Prepare croissants (chilled ready dough). Put on baking paper on Universal tray. Start programme, after preheating beep sounds, insert tray.		
A 8	Apple puff pastry	0.3-0.4	Universal tray	3
		Put Apple Puff Pastries on baking paper on Universal tray. Start programme, after preheating beep sounds, insert tray.		
A 9	Quiche Lorraine	1.2-1.5	Wire rack	2
		Prepare quiche dough, put in a round quiche dish with 25 cm diameter. Start programme, after preheating beep sounds add filling and put dish in the centre of rack.		
A 10	White loaf bread	0.6-0.7	Wire rack	3
		Prepare dough and put into a black metal rectangular baking dish (length 25cm). Start programme, after preheating beep sounds put dish in the centre of rack.		
A 11	Mixed grain loaf bread	0.8-0.9	Wire rack	3
		Prepare dough and put into a black metal rectangular baking dish (length 25cm). Start programme, after preheating beep sounds put dish in the centre of rack		
A 12	Bread rolls	0.3-0.5	Universal tray	3
		Prepare rolls (chilled ready dough). Put on baking paper on Universal tray. Start programme, after preheating beep insert tray.		
A 13	Fruit crumble	0.8-1.2	Wire rack	3
		Put fresh fruits (raspberries, blackberries, apple slices, or pear slices) into oven dish 22-24 cm. Distribute crumbles on top. Start programme, after preheating beep sounds, put dish in the centre of rack.		

# Cooking Smart

Code	Food	Weight (kg)	Accessory	Level
A 14	Scones	0.5-0.6	Universal tray	3
		Put scones (5-6 cm diameter) on baking paper on tray. Start programme, after preheating beep sounds, insert tray.		
A 15	Sponge cake	0.5-0.6	Wire rack	3
		Prepare dough and put into a black metal round baking tin with 26 cm diameter. Start programme, after preheating beep sounds, put tin in the centre of rack.		
A 16	Marble cake	0.7-0.8	Wire rack	2
		Prepare dough and put into a metal round gugelhupf or bundt tin. Start programme, after preheating beep sounds, put tin in the centre of rack.		
A 17	Dutch loaf cake	0.7-0.8	Wire rack	2
		Prepare dough and put into a black metal rectangular baking dish (length 25cm). Start programme, after preheating beep sounds, put tin in the centre of rack.		
A 18	Fruit flan base	0.4-0.5	Wire rack	3
		Put the dough into a black metal buttered baking dish for cake base. Start programme, after preheating beep sounds, put tin in the centre of rack.		
A 19	Brownies	0.7-0.8	Wire rack	3
		Prepare dough using a 20-24cm ovenproof dish. Start programme, after preheating beep sounds, put dish in the centre of rack.		
A 20	Roast sirloin of beef	0.9-1.1	Wire rack + Universal tray	2
		1.1-1.3		1
		Season the beef and leave in refrigerator for 1 hour. Put on the wire rack with fat-side-up.		
A 21	Slow cooked beef roast	0.9-1.1	Wire rack + Universal tray	2
		1.1-1.3		1
		Season the beef and leave in refrigerator for 1 hour. Put on the wire rack with fat-side-up.		

Code	Food	Weight (kg)	Accessory	Level
A 22	Lamb chops	0.4-0.6	Wire rack + Universal tray	4
		0.6-0.8		1
		Marinate the lamb chops with herbs and spices and put them on wire rack.		
A 23	Leg of lamb on the bone	1.0-1.5	Wire rack + Universal tray	3
		1.5-2.0		1
		Marinate the lamb and put on wire rack.		
A 24	Pork roast with crackling	0.8-1.0	Wire rack + Universal tray	3
		1.0-1.2		1
		Put pork roast with fat side to the top on wire rack.		
A 25	Rack of pork rib	0.8-1.0	Wire rack + Universal tray	3
		1.0-1.2		1
		Put rack of pork rib on wire rack.		
A 26	Chicken, whole	0.9-1.1	Wire rack + Universal tray	2
		1.1-1.3		1
		Rinse and clean chicken. Brush chicken with oil and spices. Put it breast side down on the rack and turn over, as soon as the oven beeps.		
A 27	Chicken, breast	0.4-0.6	Wire rack + Universal tray	4
		0.6-0.8		1
		Marinate breasts and put on the rack.		
A 28	Chicken, drumsticks	0.6-0.8	Wire rack + Universal tray	4
		0.8-1.0		1
		Brush with oil and spices and put on tray.		
A 29	Duck breast	0.3-0.4	Wire rack + Universal tray	4
		0.4-0.5		1
		But duck breasts with fat-side up on the rack. The first setting is for medium, the second for medium-well done cooking level.		

# Cooking Smart

Code	Food	Weight (kg)	Accessory	Level
A 30	Trout fillet	0.3-0.5	Universal tray	4
		0.5-0.7		
		But trout fillets with the skin side up on the Universal tray.		
A 31	Trout	0.3-0.5	Wire rack + Universal tray	4
		0.5-0.7		1
		Rinse and clean the fish and put head to tail on the rack. Add lemon juice, salt and herbs inside fish. Cut skin surface with knife. Brush oil and salt.		
A 32	Sole	0.3-0.5	Universal tray	3
		0.5-0.7		
		Put Sole on baking paper on the universal tray. Cut surface with knife.		
A 33	Salmon fillet	0.4-0.6	Wire rack + Universal tray	4
		0.6-0.8		1
		Rinse and clean fillets or steaks. Put fillets skin side up on rack.		
A 34	Roast vegetables	0.4-0.6	Universal tray	4
		0.6-0.8		
		Rinse and prepare slices of courgette, egg plant, pepper, onion and cherry tomatoes. Brush with olive oil, herbs and spices. Distribute evenly on tray.		
A 35	Baked potato halves	0.6-0.8	Universal tray	3
		0.8-1.0		
		Cut large potatoes (each 200g) into halves lengthways. Put with cut side up on tray and brush with olive oil, herbs and spices.		
A 36	Frozen oven chips	0.3-0.5	Universal tray	3
		0.5-0.7		
		Distribute frozen oven chips evenly on tray.		

Code	Food	Weight (kg)	Accessory	Level
A 37	Frozen potato wedges	0.3-0.5	Universal tray	3
		0.5-0.7		
		Distribute frozen potato wedges evenly on tray.		
A 38	Frozen pizza	0.3-0.6	Wire rack	3
		0.6-0.9		
		Start programme, after preheating beep sounds, put the frozen pizza in the middle of the wire rack. The first setting is for thin Italian pizza, the second setting for thick pan pizza.		
A 39	Homemade pizza	0.8-1.0	Universal tray	2
		1.0-1.2		
		Prepare homemade pizza with the yeast dough and put it on the tray. The weight include dough and topping such as sauce, vegetables, ham and cheese. Start programme, after preheating beep sounds, insert tray.		
A 40	Fermentation yeast dough	0.5-0.6	Wire rack	2
		0.7-0.8		
		Prepare dough in bowl, cover with cling film. Put in centre of rack. The first setting is for pizza and cake dough, the second setting for bread dough.		

# Cooking Smart

## Dual cook

The following table presents 10 auto programmes for cooking, roasting and baking. You can use only upper cavity or lower cavity and use the upper and lower cavity at the same time. The programme contains its quantities, weight ranges and appropriate recommendations. Cooking modes and times have been pre-programmed for your convenience. You will find some recipes for the auto programmes in your instruction book.

All dual auto cook programmes include preheating and display the preheating progress. Please put the food in the oven after preheating beep.

### **▲ WARNING**

Always use oven gloves while taking out food.

Code	Food	Weight (kg)	Accessory	Level
Upper				
A 1	Potato gratin	1.0-1.5	Wire rack	3
		Prepare fresh potato gratin using an ovenproof dish, 22-24 cm. Start programme, after preheating beep sounds, put dish in the centre of rack.		
A 2	Lasagne	1.0-1.5	Wire rack	3
		Prepare homemade lasagne using 22-24 cm ovenproof dish. Start programme, after preheating beep sounds, put dish in the centre of rack.		
A 3	Chicken drumsticks	0.6-0.8	Wire rack + Universal tray	4
		0.8-1.0		1
		Brush with oil and spices and put on rack.		
A 4	Baked potato halves	0.6-0.8	Universal tray	3
		0.8-1.0		
		Cut large potatoes (each 200g) into halves lengthways. Put with cut side up on tray and brush with olive oil, herbs and spices.		
A 5	Frozen oven chips	0.3-0.5	Universal tray	3
		0.5-0.7		
		Distribute frozen oven chips evenly on tray.		

Code	Food	Weight (kg)	Accessory	Level
Lower				
A 1	Apple pie	1.2-1.4	Wire rack	2
		Prepare apple pie using a 24-26 cm round metal baking tin. Start programme, after preheating beep sounds, put tin in the centre of rack.		
A 2	Apple puff pastry	0.3-0.4	Universal tray	3
		Put Apple Puff Pastries on baking paper on Universal tray. Start programme, after preheating beep sounds, insert tray.		
A 3	Quiche Lorraine	1.2-1.5	Wire rack	2
		Prepare quiche dough, put in a round quiche dish with 25 cm diameter. Start programme, after preheating beep sounds add filling and put dish in the centre of rack.		
A 4	Frozen pizza	0.3-0.6	Wire rack	3
		0.6-0.9		
		Put the frozen pizza in the middle of the Wire rack. Start programme, after preheating beep sounds, insert rack. The first setting is for thin Italian pizza, the second setting for thick pan pizza.		
A 5	Homemade pizza	0.8-1.0	Universal tray	2
		1.0-1.2		
		Prepare homemade pizza with the yeast dough and put it on the tray. The weight include dough and topping such as sauce, vegetables, ham and cheese. Start programme, after preheating beep sounds, insert tray.		

# Cooking Smart

## Test Dishes

According to standard EN 60350-1

### 1. Baking

The recommendations for baking refer to a preheated oven. Do not use the fast preheat function. Always put trays the slanted side to the door front.



Type of food	Accessory	Level	Type of heating	Temp. (°C)	Time (min.)
Small cakes	Universal tray	3		165	25-30
		2		165	25-30
		1+4		155	35-40
Shortbread	Universal tray + universal tray	1+4		140	32-37
Fatless sponge cake	Wire rack + Spring form cake tin (Dark coated, ø 26 cm)	2		160	35-40
		2		160	35-40
		1+4		155	45-50
Apple pie	Wire rack + 2 Spring form cake tins *(Dark coated, ø 20 cm)	1 placed diagonally		160	70-80
	Universal tray + Wire rack + 2 Spring form cake tins **(Dark coated, ø 20 cm)	1+3		160	80-90

\* Two cakes are arranged on the grid at the back left and at the front right.

\*\* Two cakes are arranged in the center on top of each other.

## 2. Grilling

Preheat the empty oven for 5 minutes using Large Grill function.

Type of food	Accessory	Level	Type of heating	Temp. (°C)	Time (min.)
White bread toast	Wire rack	5		300 (max)	1-2
Beef burgers* (12 ea)	Wire rack + Universal tray (to catch drippings)	4 1		300 (max)	1 <sup>st</sup> 15-18 2 <sup>nd</sup> 5-8

\* Turn over after  $\frac{2}{3}$  of the cooking time.

## 3. Roasting

Type of food	Accessory	Level	Type of heating	Temp. (°C)	Time (min.)
Whole chicken	Wire rack + Universal tray (to catch drippings)	3 1		205	80-100*

\* Turnover after half of time.

# Cooking Smart

---

## Collection of frequent Auto cook recipes

---

### Potato gratin

- Ingredients** 800 g potatoes, 100 ml milk, 100 ml cream, 50 g beaten whole egg, 1 tbsp each of salt, pepper, nutmeg, 150 g grated cheese, butter, thyme
- Directions** Peel potatoes and slice them to 3 mm thickness. Rub the butter all over the surface of a gratin dish (22-24 cm). Spread the slices on a clean towel and keep them covered with the towel while you prepare the rest of the ingredients.  
Mix the rest of the ingredients except for grated cheese into a large bowl and stir well. Layer the potato slices in the dish slightly overlapping and pour the mixture over the potatoes. Spread the grated cheese over the top and bake. After cooking, serve sprinkled with a few fresh thyme leaves.

### Vegetable gratin

- Ingredients** 800 g vegetables (courgette, tomato, onion, carrot, pepper, pre-cooked potatoes), 150 ml cream, 50 g beaten whole egg, 1 tbsp each of salt, herb (pepper, parsley or rosemary), 150 g grated cheese, 3 tbsp olive oil, some thyme leaves
- Directions** Wash the vegetables and slice them to 3-5 mm thickness. Layer the slices on a gratin dish (22-24 cm) and pour the oil on the vegetables. Mix the rest of the ingredients except for grated cheese and pour on the vegetables. Spread the grated cheese over the top and bake. Then serve sprinkled with a few fresh thyme leaves.

---

## Lasagne

**Ingredients** 2 tbsp olive oil, 500 g minced beef, 500 ml tomato sauce, 100 ml beef stock, 150 g dried lasagne sheets, 1 onion (chopped), 200 g grated cheese, 1 tsp each of dried parsley flakes, oregano, basil

**Directions** Prepare tomato meat sauce. Heat the oil in a frying pan, then cook the minced beef and chopped onion for about 10 min until browned all over. Pour over the tomato sauce and beef stock, add the dried herbs. Bring up to the boil, then simmer for 30 min.  
Cook lasagne noodles according to package directions. Layer the lasagne noodle, meat sauce, and cheese then repeat. Then sprinkle evenly with remaining cheese on the top of layer of noodles and bake.

## Apple pie

**Ingredients**

- **Pastry:** 275 g flour,  $\frac{1}{2}$  tbsp salt, 125 g white castor sugar, 8 g vanilla sugar, 175 g cold butter, 1 egg(beat)
- **Filling:** 750 g firm whole apples, 1 tbsp lemon juice, 40 g sugar,  $\frac{1}{2}$  tbsp cinnamon, 50 g seedless raisins, 2 tbsp bread crumbs

**Directions** Sift the flour with the salt above a big bowl. Sift the castor sugar and vanilla sugar with it. Cut with 2 knives the butter through the flour in small cubes. Add  $\frac{3}{4}$  of the beaten egg. Knead all the ingredients in the food processor until a crumbly mass appears. Form the dough into a ball with your hands. Wrap it in plastic foil and leave it chilled for about 30 min.  
Grease the spring tin (24-26 cm diameter) and dust the surface with flour. Roll out  $\frac{3}{4}$  of the dough till 5 mm thickness. Put it in the tin (bottom and sides).  
Peel and core the apples. Cut them in cubes of about  $\frac{3}{4} \times \frac{3}{4}$  cm. Sprinkle the apples with lemon juice and mix well. Wash and dry the currants and raisins. Add sugar, cinnamon, raisins and currants. Mix well and sprinkle the bottom of dough with bread crumbs. Press slightly. Roll out the rest of the dough. Cut the dough in small strips and put them cross wise on the filling. Brush the pie evenly with the rest of the beaten egg.

# Cooking Smart

---

## Quiche Lorraine

- Ingredients**
- **Pastry:** 200 g plain flour, 80 g butter, 1 egg
  - **Filling:** 75 g cubed fatless bacon, 125 ml cream, 125 g crème fraiche, 2 eggs, beaten, 100 g grated cheese from Switzerland, salt and pepper

**Directions** To make the pastry, put the flour, butter and egg in a bowl and mix to a soft dough. Roll out the dough and place it in the greased ceramic dish for quiche (25 cm diameter). Prick the bottom with a fork. Mix the egg, cream, crème fraiche, cheese, salt and pepper. Pour it on the pastry just before baking.

## Fruit crumbles

- Ingredients**
- **Topping:** 200 g flour, 100 g butter, 100 g sugar, 2 g salt, 2 g cinnamon powder
  - **Fruit:** 600 g mixed fruits

**Directions** Mix all ingredients until to be crumble for making topping. Spread the mixed fruits into an oven dish and sprinkle the crumble.

## Homemade pizza

- Ingredients**
- **Pizza dough:** 300 g flour, 7 g dried yeast, 1 tbsp olive oil, 200 ml warm water, 1 tbsp sugar and salt
  - **Topping:** 400 g sliced vegetable (aubergine, courgette, onion, tomato), 100 g ham or bacon(chopped), 100 g grated cheese

**Directions** Put the flour, yeast, oil, salt, sugar and warm water in a bowl and mix to a wet dough. Knead in a mixer or by hand about 5-10 min. Cover with lid and place in oven for 30 min at 35 °C to prove. Roll out the dough on a floured surface into a rectangle shape and put on the tray or pizza pan. Spread the tomato puree on the dough and place ham, mushroom, olive and tomato. Sprinkle evenly with cheese on the top and bake.

---

## Roast sirloin of beef

**Ingredients** 1 kg sirloin of beef joint, 5 g salt, 1 g pepper, 3 g each of rosemary, thyme

**Directions** Season the beef with salt, pepper and rosemary and leave in refrigerator for 1 hour. Put on the Wire rack. Put it in the oven and cook.

## Herb roasted lamb chops

**Ingredients** 1 kg lamb chops (6 pieces), 4 large garlic cloves (pressed), 1 tbsp fresh thyme (crushed), 1 tbsp fresh rosemary(crushed), 2 tbsp salt, 2 tbsp olive oil

**Directions** Mix the salt, garlic, herbs and oil and add the lamb. Turn to coat and leave at a room temperature at least 30 min to 1 hour.

## Rack of Pork rib

**Ingredients** 2 racks pork spare ribs, 1 tbsp black peppercorns, 3 bay leaves, 1 onion (chopped), 3 garlic cloves (chopped), 85 g brown sugar, 3 tbsp Worcestershire sauce, 2 tbsp Tomato puree, 2 tbsp olive oil

**Directions** Make a barbecue sauce. Heat oil in a sauce pan and add the onion. Cook until softened and add remaining ingredients. Broil and reduce heat and simmer for 30 min until thickened. Marinate the rib with the barbecue sauce at least 30 min to 1 hour.

# Maintenance

---

## Cleaning

---

### **▲ WARNING**

- Make sure the oven and accessories are cool before cleaning.
- Do not use abrasive cleaning agents, hard brushes, scouring pads or cloths, steel wool, knives or any other abrasive materials.

### Oven interior

- For cleaning the interior of the oven, use a clean cloth and a mild cleaning agent or warm soapy water.
- Do not hand-clean the door seal.
- To avoid damaging the enamelled oven surfaces, only use standard oven cleaners.
- To remove stubborn soils, use a special oven cleaner.

### Oven exterior

For cleaning the exterior of the oven such as the oven door, handle, and display, use a clean cloth and a mild cleaning detergent or warm soapy water, and dry with a kitchen roll or dry towel.

Grease and dirt can remain, especially around the handle because of the hot air coming from inside. It is recommended to clean the handle after each use.

### Accessories

Wash the accessories after every use, and dry it with a tea towel. To remove stubborn impurities, soak the used accessories in warm soapy water for about 30 minutes before washing.

### Catalytic enamel surface (applicable models only)

The removable parts are coated with dark grey catalytic enamel. They can be soiled with oil and fat spattered by the circulating air during convection heating. However, these impurities burn off at oven temperatures of 200 °C or above.

- 1.** Remove all accessories from the oven.
- 2.** Clean the interior of the oven.
- 3.** Select Convection mode with max temperature, and run the cycle for an hour.

## Door

Do not remove the oven door unless for cleaning purposes. To remove the door for cleaning, follow these instructions.

### **⚠ WARNING**

The oven door is heavy.

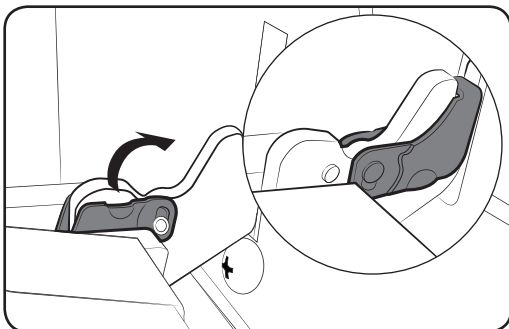
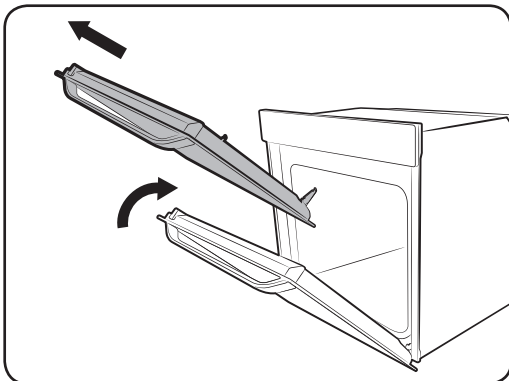
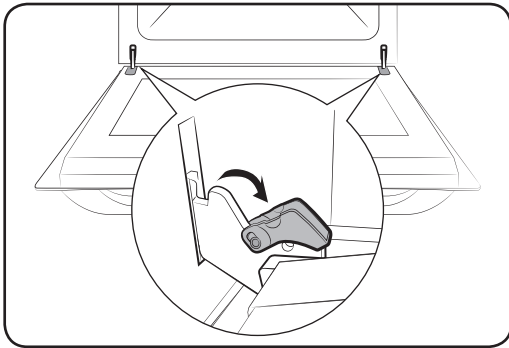

1. Open the door and flip open the clips at both hinges.
2. Close the door approximately 70°. Hold the oven door by the sides using both hands, and lift and pull upwards until the hinges are removed.
3. Clean the door with soapy water and a clean cloth.
4. When done, follow steps 1 to 2 above in the reverse order to reinstall the door. Make sure the clips are hinged on both sides.

# Maintenance

## Door glass

Depending on the model, the oven door is equipped with 3-4 sheets of glass placed against each other. Do not remove the door glass unless for cleaning purposes. To remove the door glass for cleaning, follow these instructions.

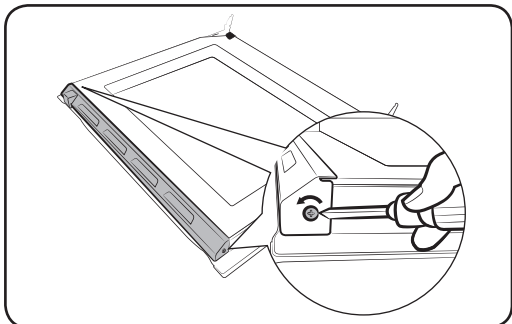

1. Use a screwdriver to remove the screws on the left and right sides.

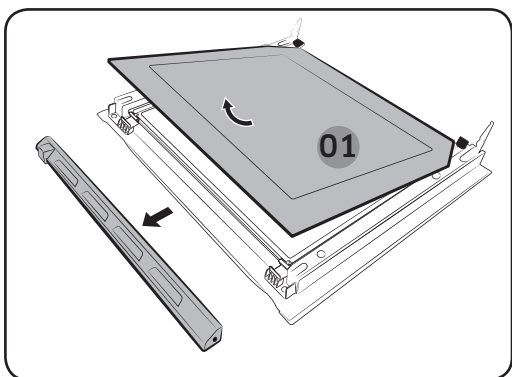

2. Detach the coverings in the arrow directions
3. Remove the first sheet from the door.

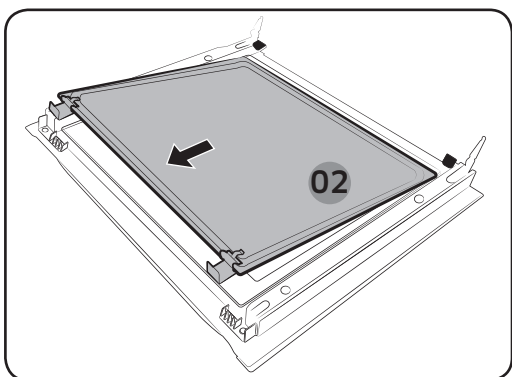

4. Remove the second sheet from the door in the arrow direction.

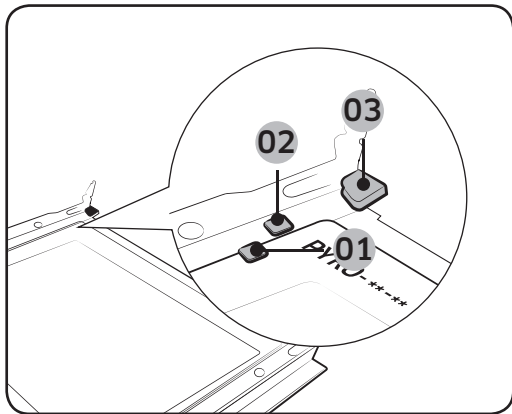
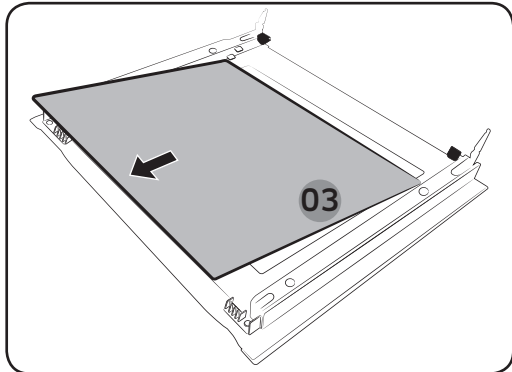

- 01** Support clip 1
- 02** Support clip 2
- 03** Support clip 3

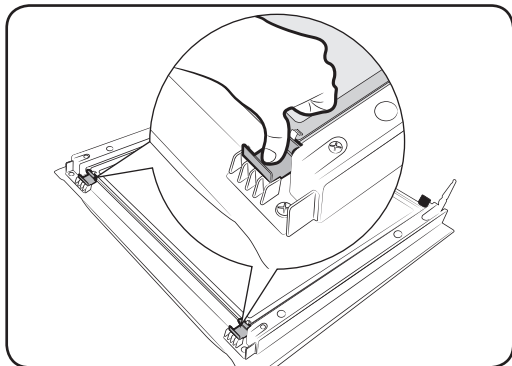

- 5.** Remove the third sheet from the door in the arrow direction.
- 6.** Clean the glass with soapy water and a clean cloth.

- 7.** When done, reinsert the sheets as follows:
  - See the picture and locate the hinges. Insert sheet 3 below support clip 1, sheet 2 between support clip 1 and 2, and sheet 1 into support clip 3 in this order. Make sure the printed side of sheets is inserted inward.

**⚠ CAUTION**

To identify the correct side of the sheet, locate the "PYRO" mark on the corner of every sheet.

Correct direction: PYRO-\*\*-\*\*

Wrong direction: \*\*-\*\*-ORYQ

- 8.** After insert the sheet 2, press down the glass clips and check if they secure the glass sheet properly.
- 9.** Follow steps 1-2 above in the reverse order to reinstall the coverings.

**⚠ WARNING**

To prevent heat leaks, make sure you properly reinsert the glass sheets.

# Maintenance

## Water collector

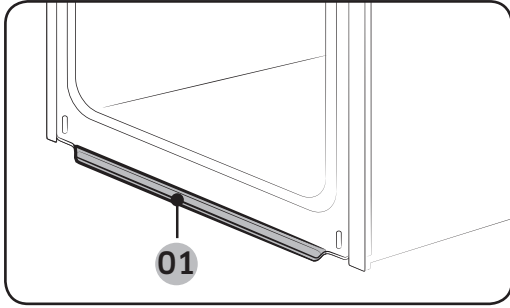

01 Water collector

The water collector collects not only excess moisture from cooking but also food residue. Regularly empty and clean the water collector.

### ⚠ WARNING

If you encounter a water leak from the water collector, contact us at a local Samsung service center.

## Side runners (applicable models only)

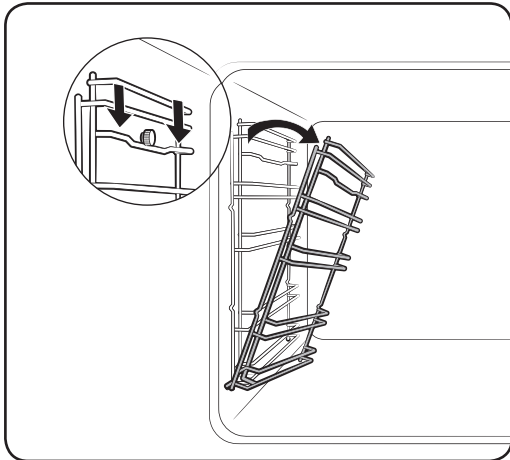

1. Press the top line of the left side runner, and lower by approximately 45°.

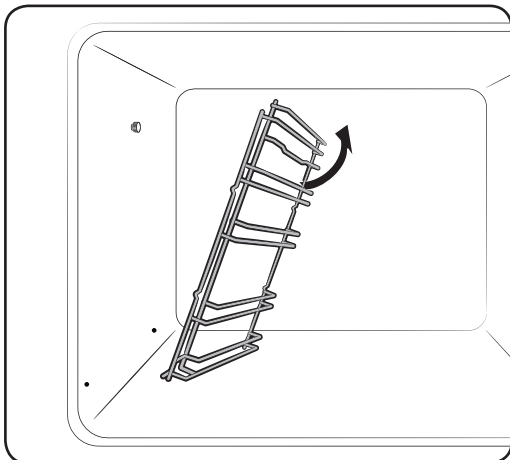

2. Pull and remove the bottom line of the left side runner.
3. Remove the right side runner in the same way.
4. Clean both side runners.
5. When done, follow steps 1 to 2 above in the reverse order to reinsert the side runners.

### 📄 NOTE

The oven operates without the side runners and racks in position.

## Telescopic rails (applicable models only)

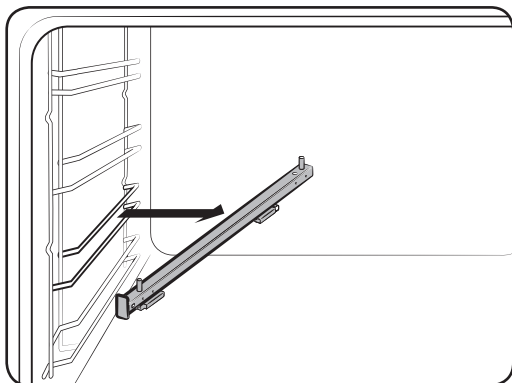

1. On the left Side runner, gently press the upper side of the rail to remove in the arrow direction.
2. Repeat the above step on the right Side runner to remove the right rail.
3. Clean the left and right Telescopic rails with soapy water and a cloth.

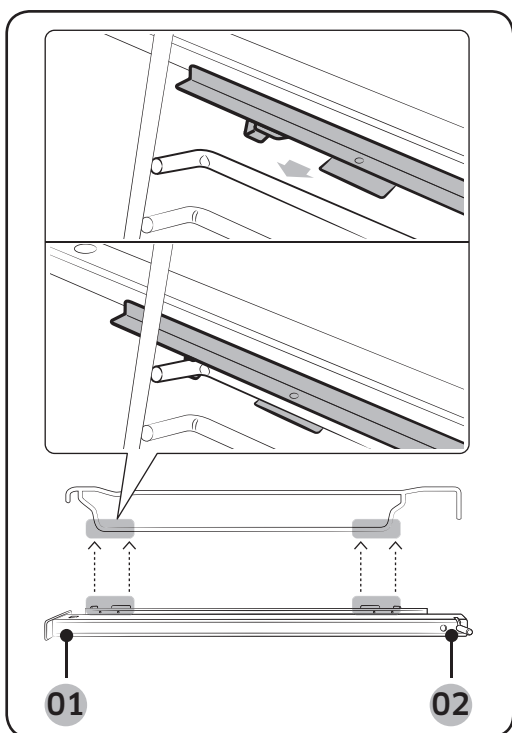

4. When cleaning is complete, reinsert both Telescopic rails by repeating steps 1-2 above in the reverse order. Make sure the front and rear clips of the rail fit into the Side runner.

### NOTE

It is recommended to insert the Telescopic rail into level 2 on the Side runner.

- 01** Front  
**02** Rear

# Maintenance

## Replacement

### Bulbs

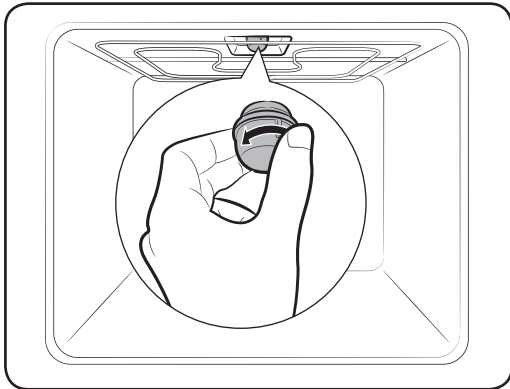

1. Remove the glass cap by turning anti-clockwise.
2. Replace the oven light.
3. Clean the glass cap.
4. When done, follow step 1 above in the reverse order to reinsert the glass cap.

### **▲ WARNING**

- Before replacing a bulb, turn off the oven and unplug the power cord.
- Use only 25-40 W/220-240 V, 300 °C heat-resistant bulbs. You can purchase approved bulbs at a local Samsung service center.

- Always use a dry cloth when handling a halogen bulb. This is to prevent the bulb from being tampered with fingerprints or sweat, resulting in a shortened lifecycle.

### Side oven light

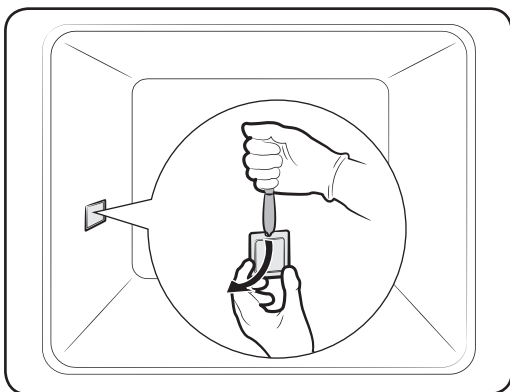

1. Hold the lower end of the cover of the side oven light with one hand, and use a flat-sharp tool such as a table knife to remove the cover as shown.
2. Replace the side oven light.
3. Reinsert the light cover.

# Troubleshooting

## Checkpoints

If you encounter a problem with the oven, first check the table below and try the suggestions. If the problem continues, contact a local Samsung service centre.

Problem	Cause	Action
The buttons cannot be pressed properly.	<ul style="list-style-type: none"><li>• If there is foreign matter caught between the buttons</li><li>• Touch model: if there is moisture on the exterior</li><li>• If the lock function is set</li></ul>	<ul style="list-style-type: none"><li>• Remove the foreign matter and try again.</li><li>• Remove the moisture and try again.</li><li>• Check whether the lock function is set.</li></ul>
The time is not displayed.	<ul style="list-style-type: none"><li>• If there is no power supplied</li></ul>	<ul style="list-style-type: none"><li>• Check whether there is power supplied.</li></ul>
The oven does not work.	<ul style="list-style-type: none"><li>• If there is no power supplied</li></ul>	<ul style="list-style-type: none"><li>• Check whether there is power supplied.</li></ul>
The oven stops while in operation.	<ul style="list-style-type: none"><li>• If it is unplugged from the power socket</li></ul>	<ul style="list-style-type: none"><li>• Reconnect the power.</li></ul>
The power turns off during operation.	<ul style="list-style-type: none"><li>• If continuous cooking takes a long time</li><li>• If the cooling fan does not work</li><li>• If the oven is installed in a place without good ventilation</li><li>• When using several power plugs in the same socket</li></ul>	<ul style="list-style-type: none"><li>• After cooking for a long time, let the oven cool.</li><li>• Listen for the sound of the cooling fan.</li><li>• Keep the gaps specified in the product installation guide.</li><li>• Use a single plug.</li></ul>
There is no power to the oven.	<ul style="list-style-type: none"><li>• If there is no power supplied</li></ul>	<ul style="list-style-type: none"><li>• Check whether there is power supplied.</li></ul>
The oven exterior is too hot during operation.	<ul style="list-style-type: none"><li>• If the oven is installed in a place without good ventilation</li></ul>	<ul style="list-style-type: none"><li>• Keep the gaps specified in the product installation guide.</li></ul>
The door cannot be opened properly.	<ul style="list-style-type: none"><li>• If there is food residue stuck between the door and product interior</li></ul>	<ul style="list-style-type: none"><li>• Clean the oven well and then open the door again.</li></ul>

# Troubleshooting

Problem	Cause	Action
The interior light is dim or does not turn on.	<ul style="list-style-type: none"> <li>If the lamp turns on and then off</li> <li>If the lamp is covered by foreign matter during cooking</li> </ul>	<ul style="list-style-type: none"> <li>The lamp automatically turns off after a certain amount of time to save power. You can turn it on again by pressing the oven light button.</li> <li>Clean the inside of the oven and then check.</li> </ul>
Electric shock occurs on the oven.	<ul style="list-style-type: none"> <li>If the power is not properly grounded</li> <li>If you are using a socket without grounding</li> </ul>	<ul style="list-style-type: none"> <li>Check whether the power supply is properly grounded.</li> </ul>
There is water dripping.	<ul style="list-style-type: none"> <li>There may be water or steam in some cases depending on the food. This is not a product malfunction.</li> </ul>	<ul style="list-style-type: none"> <li>Let the oven cool and then wipe with a dry dish towel.</li> </ul>
There is steam through a crack in the door.		
There is water remaining in the oven.		
The brightness inside the oven varies.	<ul style="list-style-type: none"> <li>The brightness changes depending on power output changes.</li> </ul>	<ul style="list-style-type: none"> <li>Power output changes during cooking are not malfunctions, so there is no need to worry.</li> </ul>
Cooking is finished, but the cooling fan is still running.	<ul style="list-style-type: none"> <li>The fan automatically runs for a certain amount of time to ventilate inside the oven.</li> </ul>	<ul style="list-style-type: none"> <li>This is not a product malfunction, so there is no need to worry.</li> </ul>
The oven does not heat.	<ul style="list-style-type: none"> <li>If the door is open</li> <li>If oven controls are not correctly set</li> <li>If the household fuse has been blown or the circuit breaker has been tripped.</li> </ul>	<ul style="list-style-type: none"> <li>Close the door and restart.</li> <li>Refer to the chapter on oven operation and reset the oven.</li> <li>Replace the fuse or reset the circuit. If it happens repeatedly, call an electrician.</li> </ul>

<b>Problem</b>	<b>Cause</b>	<b>Action</b>
Smoke comes out during operation.	<ul style="list-style-type: none"> <li>• During initial operation</li> <li>• If there is food on the heater</li> </ul>	<ul style="list-style-type: none"> <li>• Smoke may come from the heater when you first use the oven. This is not a malfunction, and if you run the oven 2-3 times, it should stop happening.</li> <li>• Let the oven cool sufficiently and remove the food from the heater.</li> </ul>
There is a burning or plastic smell when using the oven.	<ul style="list-style-type: none"> <li>• If using plastic or other containers that are not heat-resistant</li> </ul>	<ul style="list-style-type: none"> <li>• Use glass containers suitable for hot temperatures.</li> </ul>
The oven does not cook properly.	<ul style="list-style-type: none"> <li>• If the door is often opened during cooking</li> </ul>	<ul style="list-style-type: none"> <li>• Do not frequently open the door unless you are cooking things that need to be turned. If you frequently open the door, the interior temperature will be lower and this may affect the results of your cooking.</li> </ul>
The oven is warm during pyro cleaning.	<ul style="list-style-type: none"> <li>• This is because pyro cleaning uses high temperatures.</li> </ul>	<ul style="list-style-type: none"> <li>• This is not a product malfunction, so there is no need to worry.</li> </ul>
There is a burning smell during pyro cleaning.	<ul style="list-style-type: none"> <li>• Pyro cleaning uses high temperatures, so you may smell food residue burning.</li> </ul>	<ul style="list-style-type: none"> <li>• This is not a product malfunction, so there is no need to worry.</li> </ul>
Steam cleaning does not work.	<ul style="list-style-type: none"> <li>• This is because the temperature is too high.</li> </ul>	<ul style="list-style-type: none"> <li>• Let the oven cool and then use.</li> </ul>
Dual cook mode does not work.	<ul style="list-style-type: none"> <li>• If the divider is not properly assembled</li> </ul>	<ul style="list-style-type: none"> <li>• Insert the divider correctly and use.</li> </ul>
Single cook mode does not work.	<ul style="list-style-type: none"> <li>• If the divider is inserted in the oven.</li> </ul>	<ul style="list-style-type: none"> <li>• Take out the divider and use.</li> </ul>

# Troubleshooting

## Information codes

If the oven fails to operate, you may see an information code on the display. Check the table below and try the suggestions.

Code	Meaning	Action
<b>C-d1</b>	Door lock malfunctions	Turn off the oven and then restart. If the problem continues, turn off all power for 30 seconds or more and then reconnect. If the problem is not fixed, please contact a service centre.
<b>C-20</b>	Sensor malfunctions	
<b>C-21</b>		
<b>C-22</b>		
<b>C-F1</b>	Only occurs during EEPROM Read/ Write	
<b>C-F0</b>	If there is no communication between the main PCB and sub PCB	Turn off the oven and then restart. If the problem continues, turn off all power for 30 seconds or more and then reconnect. If the problem is not fixed, please contact a service centre.
<b>C-F2</b>	Occurs when a communication problem is maintained between the Touch IC <-> Main or Sub micom	
<b>C-d0</b>	<b>Button problem</b> Occurs when a button is pressed and held for a period of time.	Clean the buttons and make sure there is no water on/around them. Turn off the oven and try again. If the problem continues, contact a local Samsung service centre.
<b>-dC-</b>	If the divider is removed during cooking in Dual cook mode. If the divider is inserted during cooking in Single cook mode.	The divider must not be removed during cooking in Dual cook mode. Turn off the oven and then restart. If the problem continues, turn off all power for 30 seconds or more and then reconnect. If the problem is not fixed, please contact a service centre.

---

Code	Meaning	Action
<b>S-01</b>	<p><b>Safety shutoff</b> Oven has continued operating at a set temperature for an extended time.</p> <ul style="list-style-type: none"> <li>• Under 105 °C - 16 hours</li> <li>• From 105 °C to 240 °C - 8 hours</li> <li>• From 245 °C to Max - 4 hours</li> </ul>	<p>This is not system failure. Turn off the oven and remove food. Thenm try again normally.</p>



### QUESTIONS OR COMMENTS?

COUNTRY	CALL	OR VISIT US ONLINE AT
AUSTRALIA	1300 362 603	<a href="http://www.samsung.com/au/support">www.samsung.com/au/support</a>
NEW ZEALAND	0800 726 786	<a href="http://www.samsung.com/nz/support">www.samsung.com/nz/support</a>
CHINA	400-810-5858	<a href="http://www.samsung.com/cn/support">www.samsung.com/cn/support</a>
HONG KONG	(852) 3698 4698	<a href="http://www.samsung.com/hk/support">www.samsung.com/hk/support</a> (Chinese) <a href="http://www.samsung.com/hk_en/support">www.samsung.com/hk_en/support</a> (English)
INDIA	1800 3000 8282 - Toll Free 1800 266 8282 - Toll Free	<a href="http://www.samsung.com/in/support">www.samsung.com/in/support</a>
BANGLADESH	9612300300	
INDONESIA	021-56997777 08001128888	<a href="http://www.samsung.com/id/support">www.samsung.com/id/support</a>
JAPAN	0120-363-905	<a href="http://www.samsung.com/jp/support">www.samsung.com/jp/support</a>
MALAYSIA	1800-88-9999 603-77137477 (Overseas contact)	<a href="http://www.samsung.com/my/support">www.samsung.com/my/support</a>
PHILIPPINES	1-800-10-7267864 [PLDT] 1-800-8-7267864 [Globe landline and Mobile] 02-4222111 [Other landline]	<a href="http://www.samsung.com/ph/support">www.samsung.com/ph/support</a>
SINGAPORE	1800-SAMSUNG(726-7864)	<a href="http://www.samsung.com/sg/support">www.samsung.com/sg/support</a>
THAILAND	0-2689-3232, 1800-29-3232	<a href="http://www.samsung.com/th/support">www.samsung.com/th/support</a>
TAIWAN	0800-329999	<a href="http://www.samsung.com/tw/support">www.samsung.com/tw/support</a>
VIETNAM	1800 588 889	<a href="http://www.samsung.com/vn/support">www.samsung.com/vn/support</a>
MACAU	0800 333	<a href="http://www.samsung.com/support">www.samsung.com/support</a>
MYANMAR	+95-01-2399-888	
SRI LANKA	94117540540	

DG68-00615F-02