

Use & Care Guide

Cooktop

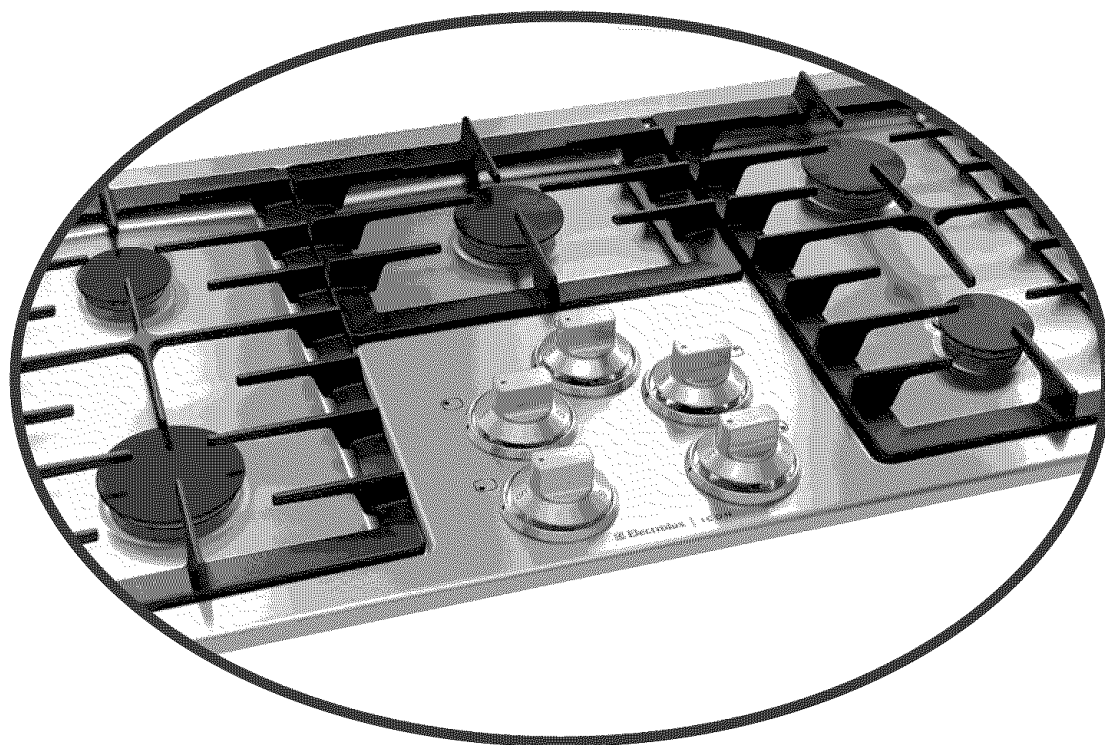

 **Electrolux**

E30GC64ESS

E36GC65ESS

E46GC66ESS

E46GC67ESS

5995426235

2 Finding Information

PLEASE READ AND SAVE THIS GUIDE

Attach your sales receipt to this page for future reference.

Thank you for choosing **Electrolux**, the new premium brand in home appliances. This *Use & Care Guide* is part of our commitment to customer satisfaction and product quality throughout the service life of your new cooktop.

We view your purchase as the beginning of a relationship. To ensure our ability to continue serving you, please use this page to record key product information.

IMPORTANT

PLEASE READ all instructions completely before attempting to install or operate the unit.

Once you have your unit installed, we suggest you keep this manual in a safe place for future reference. Should any problems occur, refer to the **Troubleshooting** section of this manual. This information will help you quickly identify a problem and get it remedied. In the event you require assistance, please contact the dealer where you purchased your unit.

MAKE A RECORD FOR QUICK REFERENCE

Whenever you call to request information or service, you will need to know your model number and serial number. You can find this information on the serial plate located on the inside wall of your unit and on the product registration card.



PRODUCT REGISTRATION CARD

The package containing this manual also includes your product registration information. Warranty coverage begins at the time your Electrolux cooktop was purchased.

If you received a damaged product, immediately contact your dealer or builder. Do not install or use a damaged appliance.

NOTE

Registering your product with Electrolux enhances our ability to serve you. You can register online (at the Internet address below) or by dropping your Product Registration Card in the mail. Complete and mail the Product Registration Card as soon as possible to validate the registration date.

Please record the purchase date of your Electrolux unit and your dealer's name, address and telephone number.

Purchase Date

Electrolux Model Number

Electrolux Serial Number

Dealer Name

Dealer Address

Dealer Telephone

Keep this manual and the sales receipt together in a safe place for further reference.

QUESTIONS?

For toll-free telephone support in the U.S. and Canada:
1-877- 4ELECTROLUX (1-877-435-3287)

For online support and Internet product information:
www.electroluxusa.com

TABLE OF CONTENTS

Finding Information	2	Care and Cleaning	15
Please Read And Save This Guide	2	Cleaning Tips	15
Make A Record For Quick Reference	2	Cleaning Stainless Steel Surfaces	18
Questions	3	Cleaning Porcelain Grates	18
Table Of Contents	4	Cleaning Knobs and Knob Bezels	19
Safety	5	Cleaning Burner Bases	19
Important Safety Instructions	5	Cleaning Burner Rings	20
General Precautions	6	Cleaning Burner Igniters	21
Cooktop Features	9	Cleaning the Gas Grill	21
Sealed Burners	9	Troubleshooting	22
Brass Burner Rings	10	If Service is Required	22
Burner Igniters	10	Troubleshooting Guide	23
Sealed Burner Configurations	10	Warranty Information	24
Knobs and Spill Protector Rings	11		
Selecting the Proper Cookware	11		
Operation	12		
Before Cooking	12		
Operating the Control Valves	12		
Setting the Burner Flame Height	14		
Energy Saving Tips	14		

IMPORTANT SAFETY INSTRUCTIONS

Safety Precautions

Do not attempt to install or operate your unit until you have read the safety precautions in this manual. Safety items throughout this manual are labeled with a Warning or Caution based on the risk type.

Definitions

 This is the safety alert symbol. It is used to alert you to potential personal injury hazards. Obey all safety messages that follow this symbol to avoid possible injury or death.

WARNING

WARNING indicates a potentially hazardous situation which, if not avoided, could result in death or serious injury.

CAUTION

CAUTION indicates a potentially hazardous situation which, if not avoided, may result in minor or moderate injury.

CAUTION

CAUTION used without the safety alert symbol indicates a potentially hazardous situation which, if not avoided, may result in property damage.

IMPORTANT

Indicates installation, operation or maintenance information which is important but not hazard related.

6 Safety

General Precautions

IMPORTANT

- Begin by ensuring proper installation and grounding of the appliance by a qualified technician according to the accompanying Installation Instructions. Have the installer show you where the fuse or junction box is located so that you know how and where to turn off power. Also, have the installer show you the location of the gas supply. If you smell gas, do not use the cooktop. Immediately turn off the gas supply at the shut off valve, disconnect electrical power to the unit at the fuse or junction box and contact the gas supplier or qualified appliance technician.
- Ensure that the cooktop is used only by those individuals who are able to operate it properly.
- Use the cooktop only for cooking tasks expected of a home appliance as outlined in this manual.
- Properly clean and maintain as recommended in this manual, cleaning only the parts listed.
- Use only dry potholders to avoid steam burns when removing hot cookware.
- In the event that a burner flame goes out and gas escapes, open a window or door. Wait at least 5 minutes before attempting to use the cooktop.
- Select utensils of the proper size, material and construction for the particular type of cooking being done. Select utensils that are large enough to contain food without boil-overs or spillovers. Choose pans with easily grasped handles that will stay cool while cooking. Do not use utensils with loose handles. Avoid using pans that are too heavy to lift safely. Use cookware only for its intended purpose. Certain types of glass, ceramic, and earthenware utensils are suitable for use only in an oven and not in cooktop applications.
- When cooking, set the burner controls so that the flame heats only the bottom of the utensil and does not lick at the sides of the utensil.
- When deep fat frying, be certain that the pan is large enough to contain the desired volume of food without overflow caused by bubbling of the fat. Never leave a deep fat fryer unattended. Avoid deep fat frying of moist or frost-covered foods. Foods with high water content may cause spattering or spilling of the hot fat. Heat fat slowly and stir together any combinations of oils and fats prior to applying heat. Utilize a deep fat frying thermometer to avoid heating the fat to temperatures above the flash point.
- Always turn pan handles to the side or back of the cooktop. Do not turn handles towards the room where they are easily hit. Handles should not extend over adjacent burners.

IMPORTANT

- Always check the positions of the control knobs to make sure the cooktop is off when you are finished cooking.
- Before performing any service, turn off the gas supply by closing the gas shut-off valve and turning off the electrical power supply.
- Always light each burner prior to placing a utensil on the burner grate. Also, turn the control knob to the “off” position before removing a utensil from the burner grate.
- Always clean the cooktop cautiously. If using a damp sponge or cloth, wait until the cooktop has cooled sufficiently to prevent steam burns. Also, some cleaners can produce harmful or unpleasant fumes if applied to hot surfaces.
- Keep any ventilation filters clean to avoid grease fires.
- Always set utensils gently onto the grates and center them so that they are well-balanced.
- Always keep the cooktop surface clean and dry.

CAUTION

- Do not use the cooktop for warming or heating the room.
- Do not leave children alone or unattended in the area where the cooktop is in use. Never allow children to sit or stand on any part of the cooktop. Do not let children play with the cooktop.
- Do not store items of interest to children above the cooktop. Children could be burned or injured while climbing on the appliance.
- Do not wear loose or hanging apparel while using the cooktop.
- Do not repair or replace any part of the cooktop unless specifically recommended in literature accompanying this appliance. All other service should be referred to a qualified technician.
- Do not use water on grease fires. A violent steam explosion may result. Smother any flames with a lid, cookie sheet or flat tray. Flaming grease can be extinguished with baking soda or a multipurpose chemical or foam extinguisher.
- Do not allow potholders to touch gas burners. Do not use a towel or bulky cloth as a potholder.
- Do not block or obstruct the holes beneath the control knobs. Blocking these holes may affect burner operation and may result in a hazard.
- When using the cooktop, do not touch the grates, burner caps, burner bases, or any other parts in proximity to the flame. These components may be hot enough to cause burns.
- If the cooktop is near a window, do not use long curtains as a window treatment. They can blow over the cooktop and create a fire hazard.
- Do not cover the burners and grates with anything except properly selected utensils. Decorative covers should not be used.
- Do not heat unopened food containers such as baby food jars and cans. Pressure buildup may cause the container to burst and cause injury.
- Do not use abrasive or caustic cleaners or detergents on this appliance, as these may cause permanent damage. Do not use aerosol cleaners, as these may be flammable or cause corrosion of metal parts.
- Do not use or attempt to use this appliance in the event of a power failure.

SEALED BURNERS

All Electrolux Icon Cooktops (E30GC64ESS, E36GC65ESS, E46GC66ESS, E46GC67ESS) are equipped with sealed burners. Burner configurations vary by cooktop size. See **Figure 1** for a detailed burner layout for your model.

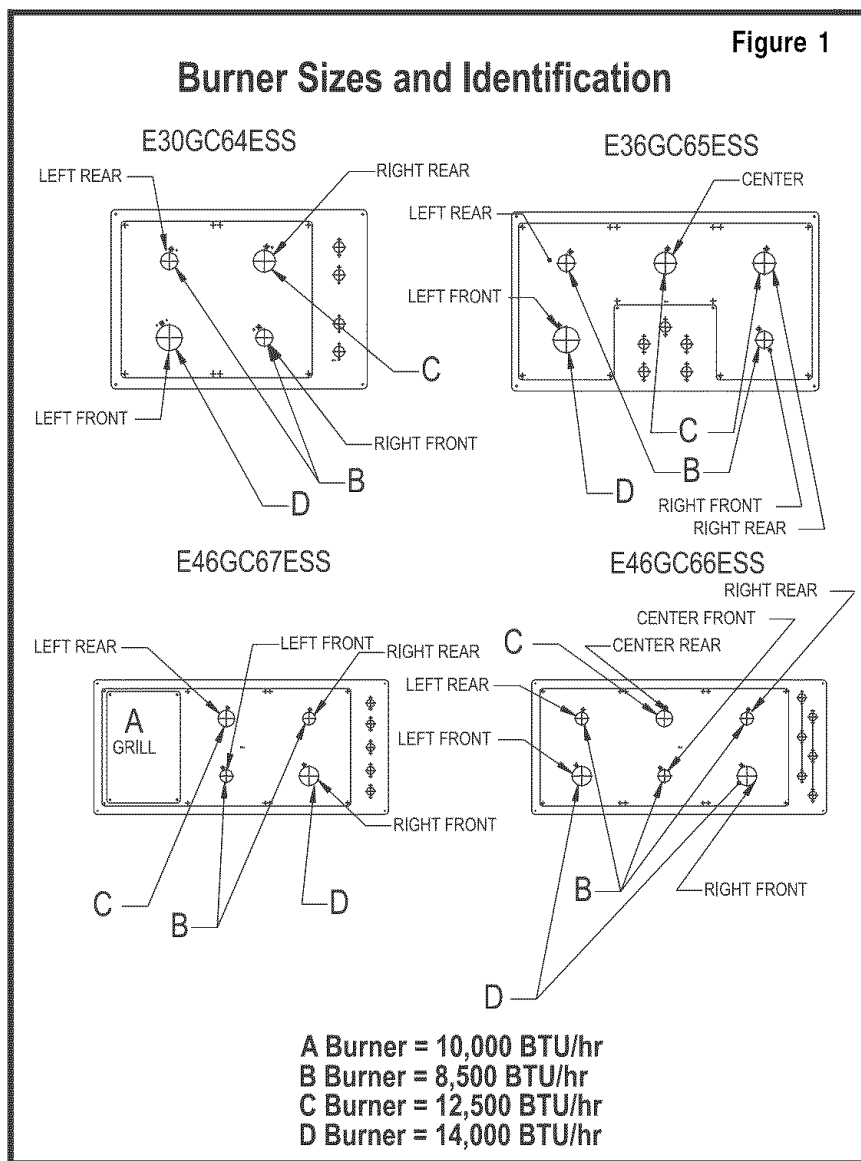

BRASS BURNER RINGS

All burners are attached to the cooktop by retaining nuts. Gaskets around the undersides of the burner cross rings and burner bases ensure that the burners are sealed, thereby preventing any liquid spills from entering the cooktop chassis. All spills remain on the surface of the cooktop.

The brass burner heads spread the flame evenly around the burner perimeters. The burner heads must seat properly in the burner cross rings or burner bases to enable proper cooktop operation. To ensure proper seating, positioning tabs have been placed on the bottom of each burner cross ring or burner head to slide into corresponding notches in the fixed burner base.

BURNER IGNITORS

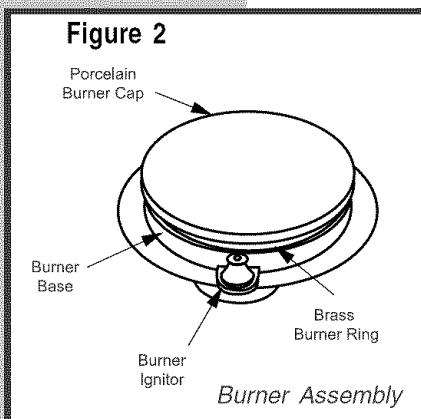

A burner igniter is located on each gas burner base. When a control knob is rotated more than 90 degrees counterclockwise, all igniters will spark simultaneously, but only the selected burner will ignite. Additionally, due to Vantage Flame™, the automatic reignition feature, the igniters will spark automatically if a flame should blow out or be severely distorted by a draft or by a ventilation system. Burner igniters must always be kept clean and dry to function properly. Dirty or wet igniters will result in constant sparking, even if there is a flame present. See **Figure 2**.

SEALED BURNER CONFIGURATIONS

On E30GC64ESS Cooktop, there are a total of four burners, including one burner rated at a maximum output of 14,000 BTU/HR, one burner rated at a maximum of 12,500 BTU/HR and two burners rated at a maximum output of 8,500 BTU/HR. The knobs are grouped in twos. The front two knobs operate the front two burners, and the rear two knobs control the two rear burners.

On the E36GC65ESS Cooktop, there are a total of five burners, including one burner rated at a maximum output of 14,000 BTU/HR, two burners rated at a maximum of 12,500 BTU/HR and two burners rated at a maximum output of 8,500 BTU/HR. The knobs are positioned to correspond with the burner layout.

On the E46GC66ESS Cooktop, there are a total of six burners, including two burners rated at a maximum output of 14,000 BTU/HR, one burner rated at a maximum of 12,500 BTU/HR and three burners rated at a maximum output of 8,500 BTU/HR. The knobs are grouped in threes. The front three knobs operate the front three burners, and the rear three knobs control the three rear burners.

On the E46GC67ESS Cooktop, there are a total of five burners, including one burner rated at a maximum output of 14,000 BTU/HR, one burner rated at a maximum of 12,500 BTU/HR, two burners rated at a maximum output of 8,500 BTU/HR and one burner rated at a maximum of 9,300 BTU/HR (gas grill burner). The front two knobs operate the front two burners, and the center knob controls the gas grill.

KNOBS AND SPILL PROTECTOR RINGS

The control knobs provided with this cooktop are designed for ease of use and longevity. The “D” shaped design of the knob shaft ensures proper orientation when reinstalling the knob. Located beneath each knob is a bezel ring that mounts to the cooktop. The umbrella shaped spill protector ring sits on the valve spindle underneath the cooktop. The spill protector is made of a silicone rubber material that is resistant to staining.

SELECTING THE PROPER COOKWARE

Utensils will affect the overall safety and performance of cooktop cooking, so it is important to select them carefully. An improperly selected utensil will not cook efficiently or evenly. For best results, follow these guidelines:

1. Use medium to heavy gauge metal cookware with flat and smooth bottoms for greatest efficiency.
2. Use utensils with tight fitting lids to retain heat, odors, and steam.

12 Operation

BEFORE COOKING

Ensure that the cooktop has been installed by a qualified individual who has tested the operation of the cooktop in accordance with the Installation Instructions. The brass burner rings, burner caps, grates, knobs and spill protectors must be in place for the cooktop to operate properly. All cooktop components must be clean. Be certain that the gas and electrical power supplies to the cooktop are operational. Read this **Use and Care Manual** in its entirety prior to operating the cooktop.

OPERATING THE CONTROL VALVES

To light a particular burner, press down on the corresponding control knob, then immediately rotate the knob counterclockwise from the “OFF” position to the “HI/LITE” position. **Only the selected burner will spark continuously until the gas ignites on that burner. The igniters will stop sparking as soon as the burner ignites.**

Once the burner is lit, reduce the flame height if desired by rotating the control knob further counterclockwise, then place the utensil on the grate. See **Figure 3**.

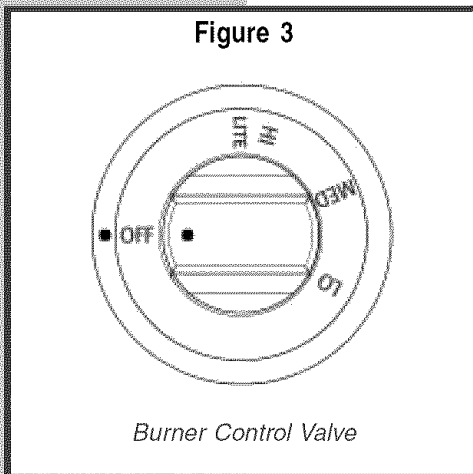

WARNING

Do not touch any burner cap, burner base, or ignitor while the ignitors are sparking, as an electrical shock could result.

IMPORTANT

- If the gas does not ignite within four seconds, turn off the valve. Allow at least two minutes for any gas to dissipate, then repeat the lighting procedure.
- Burner ignitors must always be kept clean and dry to function properly. Due to the Vantage-Flame™ reignition feature, dirty or wet ignitors will result in constant sparking, even if there is a flame present. Additionally, ignitors will spark automatically if the flame is distorted by a draft or by a cooktop ventilation system. Eliminate the draft or reduce the ventilation blower speed in this case.
- When the cooktop is cool and/or more than two burners are in use, the ignitors may continue to spark if the control knob is set to the “LOW” position. This is normal until the burner warms up. The tendency to spark under these conditions can be reduced by operating the burner at a higher flame setting for a short period of time (normally 60 seconds or less), then adjusting the control knob down to the “LOW” setting. The burner will also warm up faster if a utensil is placed on the grate.
- The flame should be steady and blue in color. Foreign material in the gas line, especially in new construction, may cause an orange flame during initial operation. This will disappear with further use.
- The flame should burn evenly around the perimeter of the burner. If the flame is uneven, ensure that the brass burner ring and porcelain burner cap are properly positioned, then check for any foreign material in the burner ring or on the burner cap. Remove any foreign material with a straightened paper clip, wire, or needle. Do not use a toothpick to remove clogs, as it could break off. Do not damage the brass or distort the shape of the burner ring ports.
- Never light the burners with a match or other open flame. If a burner does not ignite, refer to the Troubleshooting Guide.

14 Operation

SETTING THE BURNER FLAME HEIGHT

Setting the proper burner flame height for the desired cooking process and selected utensil will result in superior cooking performance, while also saving time and energy. Follow these recommendations for best results:

1. Use low or medium flame heights when cooking in utensils that are poor conductors of heat, such as glass, ceramic, and cast iron cooking vessels. Reduce the flame height until it covers approximately 1/3 of the utensil diameter. This will ensure even heating within the utensil and reduce the likelihood of burning or scorching of food.
2. Reduce the flame if it is extending beyond the bottom of the utensil. A flame that licks along the sides of the utensil is potentially dangerous, heats the utensil handle and kitchen instead of the food, and wastes energy.
3. Reduce the flame height to the minimum level necessary to perform the desired cooking process. Remember that food cooks just as quickly at a gentle boil as it does at a vigorous, rolling boil. Maintaining a higher boil than is necessary wastes energy, cooks away moisture, and causes a loss in food flavor and nutrient level.

ENERGY SAVING TIPS

- Always use utensils with flat, smooth bottoms and tight-fitting lids to retain heat and moisture.
- Minimize the amount of liquid or fat to reduce cooking times.
- Select cookware of the proper size, material and construction for the cooking process being performed.
- Adjust the flame height to fit the utensil size.
- After liquid reaches a boil, reduce the heat to maintain a simmer rather than a rolling boil.
- Use a timer rather than repeatedly removing the lid to check food.
- Thaw foods prior to cooking to reduce cooking time.

CLEANING TIPS

No maintenance, other than the **Care and Cleaning** identified in this **Use & Care Manual**, should be attempted by the owner/operator. All other maintenance and service must be performed by a qualified appliance technician.

WARNING

To avoid electrical shock or burns, turn off all controls and ensure the cooktop is cool before cleaning.

IMPORTANT

Do not use harsh or abrasive cleaning agents, waxes, polishes, or commercial cooktop cleaners to clean the cooktop.

Read and follow the **Care and Cleaning** instructions to ensure that proper cooktop operation and appearance will be maintained throughout the lifetime of the product. Several materials and finishes are used in the cooktop. Each material and finish must be properly cleaned according to the following recommendations. Failure to follow these recommendations may result in permanent damage to the cooktop.

WARNING

- Before cleaning the cooktop, ensure that all burners are turned off and that all components are cool enough to safely touch.
- After cleaning, reassemble all components before attempting to operate the cooktop.

Proper cleaning is necessary to maintain cooktop performance and appearance, while also ensuring safe operation. The cleaning effort necessary to maintain the cooktop varies according to the type and amount of cooking. For example, more frequent cleaning is required if the cooktop is used often for frying or other high temperature operations.

Clean the cooktop thoroughly prior to operating it the first time. For initial and everyday cleaning, use a soft cloth or sponge lightly dampened with a solution of warm water and hand dishwashing liquid to clean all components.

16 Care and Cleaning

IMPORTANT

- To keep the cooktop looking its best, clean it after every use as soon as all components are cool enough to safely touch. Also, quickly wipe up spills that occur while cooking, being careful not to touch any hot areas. Spills that remain on hot burner components will be very difficult to clean, especially if allowed to burn on. Spills of certain foods, such as tomatoes, citrus juices, vinegar, alcohol, and milk, are very harmful if allowed to stand for any length of time. Therefore, save time while also maintaining a new appearance by cleaning regularly and shortly after spills occur.
- Use the mildest cleaner or procedure available to perform the cleaning operation.
- Use only a sponge, soft cloth, fibrous or plastic brush, and nylon pad for cleaning. Avoid the use of abrasive cleaners and steel wool.
- Always dry components completely before using the cooktop.

Recommendations for cleaning specific cooktop components are summarized below:

IMPORTANT

The grates and burner caps, unlike other porcelain enamel appliances in your home, are exposed to extremely high temperatures in a matter of seconds. In addition to this extreme thermal shock, the grates are subjected to mechanical shock when utensils are placed on or slid across them. Finally, spillovers introduce foods with high acidity to all of the porcelain components. *Due to these severe operating conditions, all porcelain enamel components on the cooktop will undergo an inevitable change in appearance with use.* Meticulous care and cleaning will slow but not eliminate this natural and expected aging process.

Treating the porcelain components with care will slow the natural deterioration that takes place with cooktop use. Please follow these guidelines to keep the porcelain parts looking their best:

1. Do not use utensils having rough bottoms, as this can result in permanent damage to the top surfaces of the porcelainized grates.
2. Do not drop utensils onto the grates or drag heavy pots across the tops of the grates.
3. Set the grates into the locating dimples gently. Do not drop the grates into place.
4. Use caution when cooking to avoid spills as much as possible. Porcelain is acid-resistant but not acid-proof, so some foods can cause permanent damage if allowed to remain on porcelain surfaces.

Daily cleaning of the grates, burner heads, and burner caps is best accomplished with a soft cloth or sponge dampened in a solution of warm water and hand dishwashing liquid. Grates are dishwasher safe. Burner caps should not be cleaned in the dishwasher.

Stubborn stains may be removed by applying full-strength, all purpose cleaning sprays. (If you are unable to locate these cleaning compounds, please phone the Electrolux Customer Service Department for a referral.)

Mildly abrasive cleaners or applicators, such as soap-filled steel wool pads, may be used with extreme care on occasion to remove the most serious stains. **Exercise caution – extensive use of abrasives will eventually damage the porcelain enamel surface.**

18 Care and Cleaning

CLEANING STAINLESS STEEL SURFACES

Clean these surfaces with the provided Stainless Steel Cleaner. Rinse and dry with a soft lint-free cloth.

IMPORTANT

If commercially available stainless steel cleaners are used, it is important to read the labels for chlorine compounds. Chlorine is a corrosive substance. If these compounds are present, rinse thoroughly and dry with a soft lint-free cloth.

Always wipe stainless steel surfaces with the grain.

CLEANING PORCELAIN GRATES

Clean the porcelain grates with a solution of mild detergent and hot water. Rinse with a soft cloth. Do not use abrasives or commercial oven cleaners.

Stubborn stains may be removed by washing the grates in a dishwasher, using normal dishwashing detergent.

IMPORTANT

Never use the cooktop surface as a cutting board.

Do not use abrasive cleaners or applicators on the cooktop.

Do not try to remove heavy spills with a sharp object such as a knife or metal spatula. Sharp objects may scratch the cooktop.

A small amount of baby oil may be applied to stainless steel tops to restore the lustre.

CLEANING KNOBS AND KNOB BEZELS

The control knobs provided with this cooktop are designed for ease of use and longevity. The “D” shaped design of the knob shaft ensures proper orientation when reinstalling the knob.

IMPORTANT

Never block the holes in the control panel beneath the knobs, because this will impair the flow of combustion air and adversely affect burner operation, possibly creating a hazardous condition.

The knobs are made of a composite plastic. These components should be washed regularly in warm, soapy water. Hand dishwashing liquid is excellent for this task. Knobs should be removed by gently pulling them straight out and off of the valve shafts. The spill protectors should be cleaned in place. Use caution to avoid introduction of moisture into the control panel behind the bezels. To replace knobs, align the “D-shaped” opening at the bottom of the knob with the “D-shaped” valve shaft, then carefully press the knob onto the valve.

IMPORTANT

- Turn the knobs to the “OFF” position prior to removing them from the valve stems.
- The cooktop should never be operated without the knobs in place.
- Do not soak the knobs in water or place them in the dishwasher.
- Do not expose the knobs to direct flame, hot utensils, or other sources of heat.
- Do not use abrasive or corrosive cleaners or applicators, as these could cause permanent damage.

CLEANING BURNER BASES

The burner base is permanently attached to the cooktop. The base should be wiped clean using a soft cloth or sponge that has been lightly dampened with warm water and hand dishwashing liquid. Thoroughly clean and dry the igniters to prevent constant sparking of the reignition system. Refer to the **Cleaning the Burner Igniters** section for cleaning tips.

20 Care and Cleaning

CLEANING BURNER RINGS

The brass burner rings spread the flame evenly around the burner perimeters. The burner rings must seat properly in the burner bases to enable proper cooktop operation. To ensure proper seating, positioning tabs have been placed on the bottom of each burner ring to slide into corresponding notches in the fixed burner base.

To remove the burner ring, first remove the grate, then lift off the porcelain burner cap. The burner ring may then be removed from the burner base. Soak the burner ring in a warm solution of hand dishwashing liquid and water, then rinse well with clean water. Dry the burner thoroughly

Stubborn stains may be removed by applying a metal polishing compound. (If you are unable to locate this type of polishing compound, please phone the Electrolux Customer Service Department for a referral.)

CLEANING THE BURNER IGNITORS

Under certain cooking or cleaning conditions, your cooktop igniters may become coated with or corroded by food deposits, splattered grease or cleaning agents. This condition can cause erratic or continuous sparking. Keeping the igniters clean and dry will help to reduce this problem. To avoid unnecessary and costly service calls, the homeowner should perform periodic cleaning of the igniters.

To clean the igniters:

1. Be sure burners are cool to the touch. Remove the grate, burner cap and burner heads.
2. Brush completely around the igniter, including over and under the edge of the metal cap and base. Use care while cleaning here. Parts of the igniter are porcelain and can be fragile.
3. **DO NOT USE WATER** when cleaning the igniters. If a liquid must be used to clean the igniter effectively, use only a small amount of rubbing alcohol.
4. After cleaning, reinstall the burner ring, burner cap and grate. Make sure the brass burner ring is properly seated into the burner base.
5. Test the burners. If erratic clicking is still present, make sure the igniter is completely dry.

If the unit still exhibits problems after drying, please phone the Electrolux Customer Service Department for further assistance.

CLEANING THE GAS GRILL (E36GC67ESS)

Your gas grill will develop greasy areas as a normal result of use. Clean all greasy surfaces, including the heat control channel, with mild soap and a cloth.

Do not wash the U-shaped burner in a dishwasher. Clean the surface of the U-shaped burner with soapy water and a soft bristle brush. Do not submerge the burner in water. Rinse under water and dry thoroughly.

During cleaning, some material may get clogged in the holes of the gas tubing. Use a paper clip or needle to free all plugged holes of loose material. Dump out all cleaning materials from inside the U-shaped burner before reassembling the appliance.

22 Troubleshooting

IF SERVICE IS REQUIRED

First, review the recommended checks listed in the **Troubleshooting Guide**. Then, be certain that the appliance has been installed properly and is being operated correctly. Familiarize yourself with the warranty terms and conditions listed in the **Warranty** section.

If the above checks have been completed and the problem has not yet been remedied, contact the dealer where you purchased the unit. State the Model and Serial number and explain the problem. The Model and Serial number plate is located on the bottom of the chassis box.

If you do not know the name of the selling dealer or local service company, you can check online at www.electroluxusa.com or call **1-877-4Electrolux**.

TROUBLESHOOTING GUIDE

IMPORTANT

Unnecessary service calls may be expensive, frustrating and time consuming. Before you call for service, please review the potential problems, possible causes and remedies shown in the table below.

Troubleshooting – What to check when problems occur

Problem	Possible Cause	Remedy
Nothing works.	<ul style="list-style-type: none"> • Cooktop is not connected to electrical power. • Power supply is not energized. 	<ul style="list-style-type: none"> • Have cooktop connected to a properly sized electrical power supply by a qualified technician. • Have an electrician check power supply, including the house circuit breaker, wiring and fuses.
Igniters do not spark.	<ul style="list-style-type: none"> • Circuit breaker is tripped. • House fuse is blown. • Power outage in local area. 	<ul style="list-style-type: none"> • Reset circuit breaker. • Replace house fuse. • Contact power company.
Sparking, but no flame ignition.	<ul style="list-style-type: none"> • Gas shut-off valve is on "off" position. • Gas supply is interrupted. 	<ul style="list-style-type: none"> • Turn shut-off valve to "on" position. • Contact gas company.
Burners ignite but flame is extremely large, distorted or yellow.	<ul style="list-style-type: none"> • Burner ring ports are clogged. • Burner ports or burner caps are not positioned properly. • Cooktop is being operated on the wrong type of gas. • Regulator is not installed, is faulty, or is set for the wrong type of gas. 	<ul style="list-style-type: none"> • Clean burner ring ports with straightened paper clip, needle or wire. • Remove and carefully re-install burner rings and caps. • Ensure that the type of cooktop matches the gas supply (natural gas or L.P. gas). • Check installation, replace regulator, or set regulator for correct gas type.
Burner flame goes out at low setting.	<ul style="list-style-type: none"> • Low gas supply pressure. • Air intake holes around knobs are obstructed. 	<ul style="list-style-type: none"> • Contact gas company. • Remove obstruction.
Igniters spark continuously after flame ignition.	<ul style="list-style-type: none"> • Power supply is not grounded. • Power supply polarity is reversed. • Igniters are wet or dirty. 	<ul style="list-style-type: none"> • Have power supply properly grounded. • Have polarity corrected. • Clean or dry igniters.

COOKTOP WARRANTY *Your cooktop is protected by this warranty*

	WARRANTY PERIOD	THROUGH OUR AUTHORIZED SERVICERS, WE WILL:	THE CONSUMER WILL BE RESPONSIBLE FOR:
FULL ONE-YEAR WARRANTY	One year from original purchase date.	Pay all costs for repairing or replacing any parts of this product which prove to be defective in materials or workmanship.	Costs of service calls that are listed under NORMAL RESPONSIBILITIES OF THE CONSUMER.*
LIMITED WARRANTY (Applicable to the State of Alaska)	Time periods listed above.	All of the provisions of the full warranties above and the exclusions listed below apply.	Costs of the technician's travel to the home and any costs for pick up and delivery of the appliance required because of service.

In the U.S.A., your appliance is warranted by Electrolux Home Products, Inc. We authorize no person to change or add to any of our obligations under this warranty. Our obligations for service and parts under this warranty must be performed by us or an authorized Electrolux Home Products, Inc. servicer. In Canada, your appliance is warranted by Electrolux Canada Corp.

***NORMAL RESPONSIBILITIES OF THE CUSTOMER**

This warranty applies only to products in ordinary household use, and the consumer is responsible for the items listed below:

1. Proper use of the appliance in accordance with instructions provided with the product.
2. Proper installation by an authorized servicer in accordance with instructions provided with the appliance and in accordance with all local plumbing, electrical and/or gas codes.
3. Proper connection to a grounded power supply of sufficient voltage, replacement of blown fuses, repair of loose connections or defects in house wiring.
4. Expenses for making the appliance accessible for servicing, such as removal of trim, cupboards, shelves, etc., which are not a part of the appliance when it was shipped from the factory.
5. Damages to finish after installation.
6. Replacement of light bulbs and/or fluorescent tubes (on models with these features).

EXCLUSIONS

This warranty does not cover the following:

1. CONSEQUENTIAL OR INCIDENTAL DAMAGES SUCH AS PROPERTY DAMAGE AND INCIDENTAL EXPENSES RESULTING FROM ANY BREACH OF THIS WRITTEN OR ANY IMPLIED WARRANTY.

Note: Some states do not allow the exclusion or limitation of incidental or consequential damages, so this limitation or exclusion may not apply to you.

2. Service calls which do not involve malfunction or defects in workmanship or material, or for appliances not in ordinary household use. The consumer shall pay for such service calls.
3. Damages caused by services performed by servicers other than Electrolux Home Products, Inc., Electrolux Canada Corp., or its authorized servicers; use of parts other than genuine Electrolux Home Products parts; obtained from persons other than such servicers; or external causes such as abuse, misuse, inadequate power supply or acts of God.
4. Products with original serial numbers that have been removed or altered and cannot be readily determined.

IF YOU NEED SERVICE

Keep your bill of sale, delivery slip, or some other appropriate payment record. The date on the bill establishes the warranty period should service be required. If service is performed, it is in your best interest to obtain and keep all receipts. This written warranty gives you specific legal rights. You may also have other rights that vary from state to state. Service under this warranty must be obtained by contacting Electrolux Home Products, Inc. or Electrolux Canada Corp.

This warranty only applies in the 50 States of the U.S.A. and Puerto Rico, and Canada. Product features or specifications as described or illustrated are subject to change without notice. All warranties are made by Electrolux Home Products, Inc. In Canada, your appliance is warranted by Electrolux Canada Corp.

USA

1-877-4ELECTROLUX

Electrolux Home Products, Inc.
P.O. Box 212378
Augusta, GA 30917

Canada

1-866-294-9911

Electrolux Canada Corp.
6150 McLaughlin Road
Mississauga, Ontario
L5R 4C2