

This gas grill must be used only outdoors in a well-ventilated space and must not be used inside a building, garage, screened-in porch, gazebo or any other enclosed area.

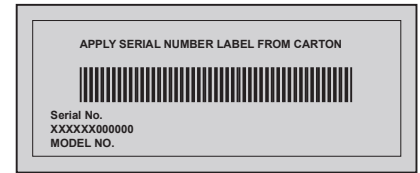

ROGUE
RXT425SB
RXT525SB
RXT625SB

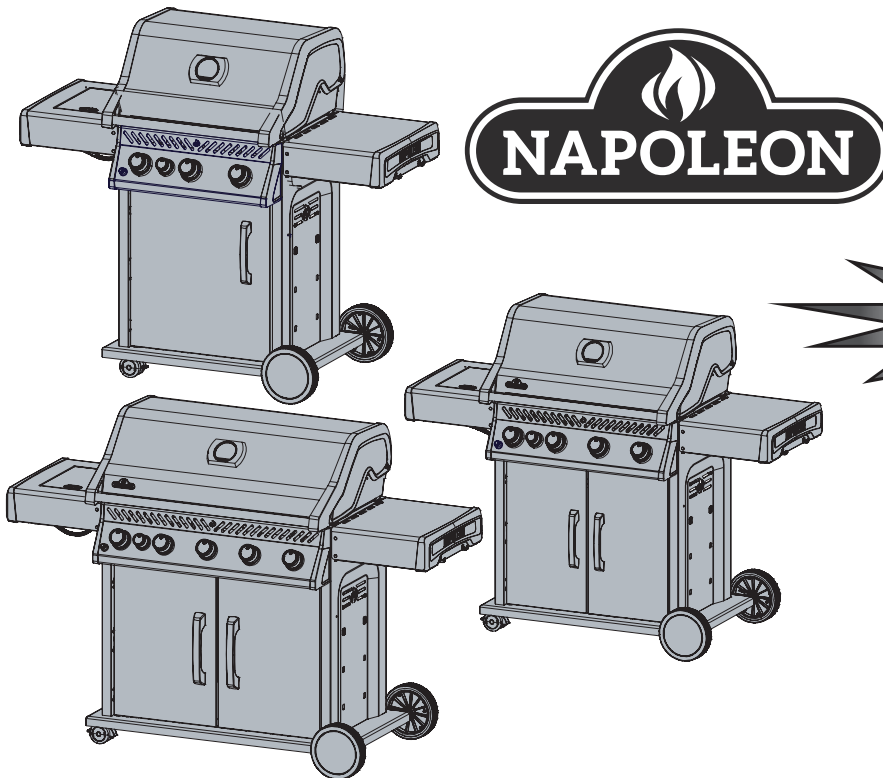

DANGER

IF YOU SMELL GAS:

- Shut off gas to the appliance.
- Extinguish any open flame.
- Open lid.
- If odor continues, keep away from the appliance and immediately call your gas supplier or fire department.



WARNING

Do not try to light this appliance without reading the “lighting” instructions section of this manual.

Do not use or store gasoline or other flammable liquids or vapors near this appliance.

A ULPG cylinder not connected for use must not be stored near this or any other appliance. If the information in these instructions is not followed exactly, a fire or explosion may result, causing property damage, personal injury or death.

Adults and especially children should be alerted to the hazards of high surface temperatures. Young children should be supervised near the gas grill.

Notice to Installer: Leave these instructions with the grill owner for future reference.



N415-0705-AU SEP 30.20

Wolf Steel Ltd.
214 Bayview Drive,
Barrie, Ontario, CANADA L4N 4Y8
grills@napoleon.com



IAPMO GMK10539
AS/NZS 5263.1.7
www.napoleon.com





Napoleon President's 15 Year Limited Warranty

NAPOLEON products are designed with superior components and materials, and are assembled by trained craftsmen who take great pride in their work. The burner and valve assembly are leak tested and test-fired at a quality test station. This grill has been thoroughly inspected by a qualified technician before packaging and shipping to ensure that you, the customer, receive the quality product you expect from NAPOLEON.

NAPOLEON warrants that components in your new NAPOLEON product will be free from defects in material and workmanship from the date of purchase, for the following period:

Aluminum castings / stainless steel base	15 years
Stainless steel lid	15 years
Porcelain enamel lid	15 years
Stainless steel cooking grids	15 years
Stainless steel tube burners	10 years full coverage, plus 50% off until the 15th year
Stainless steel sear plates	5 years full coverage, plus 50% off until the 15th year
Porcelain-enameled cast iron cooking grids	5 years full coverage, plus 50% off until the 15th year
Ceramic infrared burners (excluding screen)	5 years full coverage, plus 50% off until the 15th year
All other parts	2 years

*Conditions and Limitations

This Limited Warranty creates a warranty period as specified in the aforementioned table, for any product purchased through an authorized NAPOLEON dealer, and entitles the original purchaser to the specified coverage in respect of any component replaced within the warranty period, either by NAPOLEON or an authorized NAPOLEON dealer, to replace a component of such product that has failed in normal private use as a result of a manufacturing defect. The "50% off" indicated in the table means the component is made available to the purchaser at a 50% discount off the regular retail price of the component for the period indicated. This Limited Warranty does not cover accessories or bonus items.

For greater certainty, "normal private use" of a product means that the product: has been installed by a licensed, authorized service technician or contractor, in accordance with the installation instructions included with the product and all local and national building and fire codes; has been properly maintained; and has not been used as a communal amenity or in a commercial application.

Similarly, "failure" does not include: over-firing, blow outs caused by environmental conditions such as strong winds or inadequate ventilation, scratches, dents, corrosion, deterioration of painted and plated finishes, discoloration caused by heat, abrasive or chemical cleaners or UV exposure, chipping of porcelain enameled parts, or damages caused by misuse, accident, hail, grease fires, lack of maintenance, hostile environments such as salt or chlorine, alterations, abuse, neglect or parts installed from other manufacturers.

Should deterioration of parts occur to the degree of non-performance (rusted through or burnt through) within the duration of the warranted coverage, a replacement part will be provided. The replacement component is the sole responsibility of NAPOLEON defined by this Limited Warranty; in no event will NAPOLEON be responsible for installation, labor or any other costs or expenses related to the re-installation of a warranted part, for any incidental, consequential, or indirect damages or for any transportation charges, labor costs or export duties.

This Limited Warranty is provided in addition to any rights afforded to you by local laws. Accordingly, this Limited Warranty imposes no obligation upon NAPOLEON to keep parts in stock. Based on the availability of parts, NAPOLEON may at its discretion discharge all obligations by providing a customer a prorated credit towards a new product. After the first year, with respect to this Limited Warranty NAPOLEON may, at its discretion, fully discharge all obligations with respect to this warranty by refunding to the original warranted purchaser the wholesale price of any warranted but defective part(s).

The bill of sale or copy will be required together with a serial number and a model number when making any warranty claims from NAPOLEON. NAPOLEON reserves the right to have its representative inspect any product or part prior to honoring any warranty claim. You must contact NAPOLEON Customer Service or an authorized NAPOLEON dealer to obtain the benefit of the warranty coverage.



www.napoleon.com



WARNING! Failure to follow these instructions could result in property damage, personal injury or death. Read and follow all warnings and instructions in this manual prior to operating grill.

Safe Operating Practices

- This gas grill must be assembled exactly according to the instructions in the manual. If the grill was store assembled, you must review the assembly instructions to confirm correct assembly and perform the required leak tests before operating the grill.
- Read the entire instruction manual before operating the gas grill.
- Do not modify this appliance.
- Follow lighting instructions carefully when operating grill.
- Gas must be turned off at the Universal Liquefied Petroleum Gas cylinder when the gas grill is not in use.
- Keep children and pets away from hot grill, DO NOT allow children to climb inside cabinet.
- Do not leave the grill unattended while in use.
- Do not move grill when hot or operating.
- This gas grill must not be installed in or on recreational vehicles and/or boats.
- This gas grill must only be stored outdoors in a well-ventilated area and must not be used inside a building, garage, screened -in porch or any other enclosed area.
- Maintain proper clearance to combustibles: 26" (660mm) to rear of unit and 10" (254mm) to the sides and 47" (1200mm) above. Additional clearance is recommended near vinyl siding or panes of glass.
- It is not recommended to operate the unit under any combustible construction in case of grease fires.
- At all times keep the ventilation openings of the cylinder enclosure free and clear from debris.
- Do not locate in windy settings. High winds adversely affect the cooking performance of the gas grill.
- When the gas grill is stored indoors, the Universal Liquefied Petroleum Gas cylinder must be disconnected from the grill and stored outdoors in a well-ventilated area, disconnected cylinders must not be stored in a building, garage or other enclosed area.
- Do not use or store flammable materials in or near this appliance.
- Inspect the gas line hose before each use. If there is evidence of excessive abrasion or wear, it must be replaced before using the gas grill, with a replacement hose assembly specified by the grill manufacturer.
- Never store a spare ULPG gas cylinder under or near this grill.
- Never fill the cylinder beyond 80 % full.
- Do not attempt to use a cylinder, which is not equipped with a POL type connection.
- Periodically check the test date on the ULPG gas cylinder to ensure it is within its service life specification. If required, contact an approved testing facility or ULPG supplier for re-certification or replacement.
- Leak test all connections before initial use, even if the grill was purchased fully assembled, annually or whenever any gas component has been replaced.
- Never use natural gas in a unit designed for Universal Liquefied Petroleum Gas.
- Never use lighter fluid in a gas grill.
- Use charcoal briquettes only with a Napoleon charcoal tray designed for this unit.
- Burner controls must be off when turning supply cylinder on.
- Do not light burners with lid closed.
- Do not operate rear burner with main burners operating.
- Do not place articles on or against this appliance.
- The lid is to be closed during the pre-heat period.
- Do not route hose underneath drip pan-proper hose clearance to bottom of unit must be maintained.
- Clean grease tray and sear plates regularly to avoid build-up, which may lead to grease fires.
- Remove warming rack before lighting rear burner. The extreme heat will damage the warming rack.
- Ensure sear plates are positioned properly according to sear plate installation instructions.
- Do not spray aerosols near this appliance while it is in operation.
- Keep gas line away from heated surfaces
- Keep any electrical supply cord away from water or heated surfaces.
- Inspect infrared burner venturi tube for spider webs and other obstructions periodically. Clean the tubes completely if you find any such obstructions.

Location

Locating Your Outdoor Gas Grill

It is important when selecting a location for your gas grill to ensure clearances to adjacent combustibles are met. This appliance is intended for installation on an outdoor patio or in your yard.

'This appliance shall only be used in an above ground open-air situation with natural ventilation, without stagnant areas, where gas leakage and products of combustion are rapidly dispersed by wind and natural convection.'

Any enclosure in which the appliance is used shall comply with one of the following:

An enclosure with walls on all sides, but at least one permanent opening at ground level and no overhead cover.

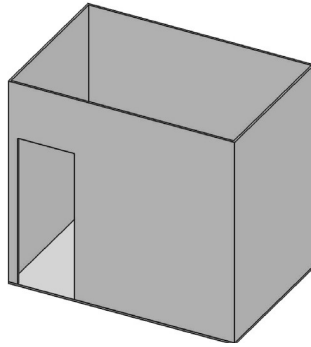

Within a partial enclosure that includes an overhead cover and no more than two sidewalls. These sidewalls may be parallel, as in a breezeway, or at right angles to each other.

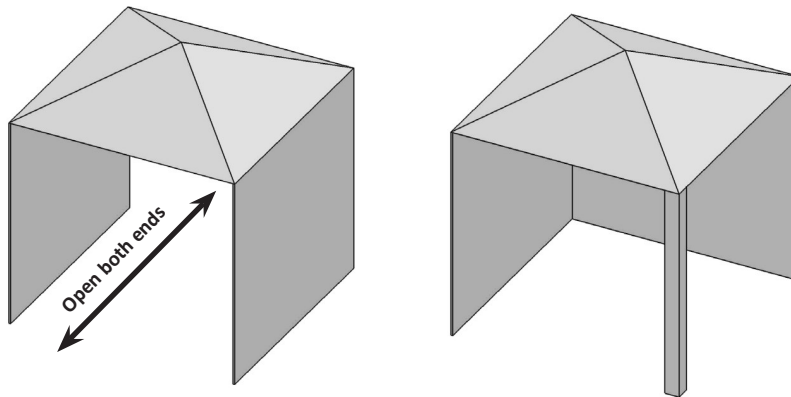

Within a partial enclosure which includes an overhead cover and more than two walls, the following shall apply:

- a) at least 25% of the total wall area is completely open; and.
- b) at least 30% of the remaining wall area is open and unrestricted.

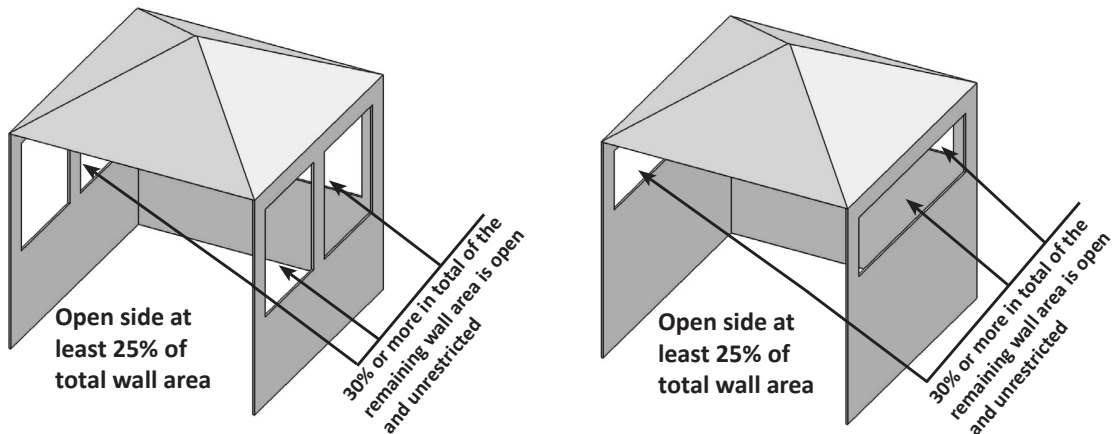

In the case of balconies, at least 20% of the total of the side, back and front wall areas shall be and remain open and unrestricted.

DIMENSIONS

RXT425SB-1 AU GRILL

3 x 14.8 MJ/h MAIN BURNER
 1 x 9.5 MJ/h SIDE BURNER (IF EQUIPPED)

GRILL SIZE: 18" X 23 3/4" = 425 in²
 WARMING RACK SIZE: 6 1/2" X 23 1/2" = 146 in²
 SIDE BURNER SIZE: 9.5" X 11.25" = 107 in²

ALL DIMENSIONS ARE APPROXIMATE

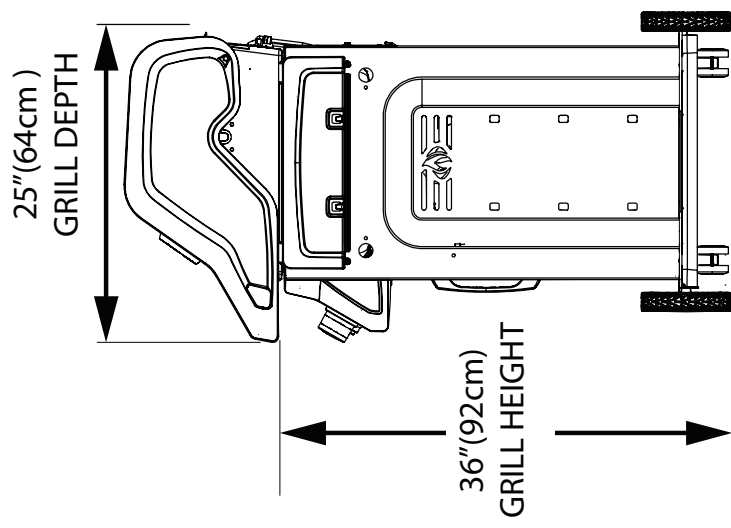
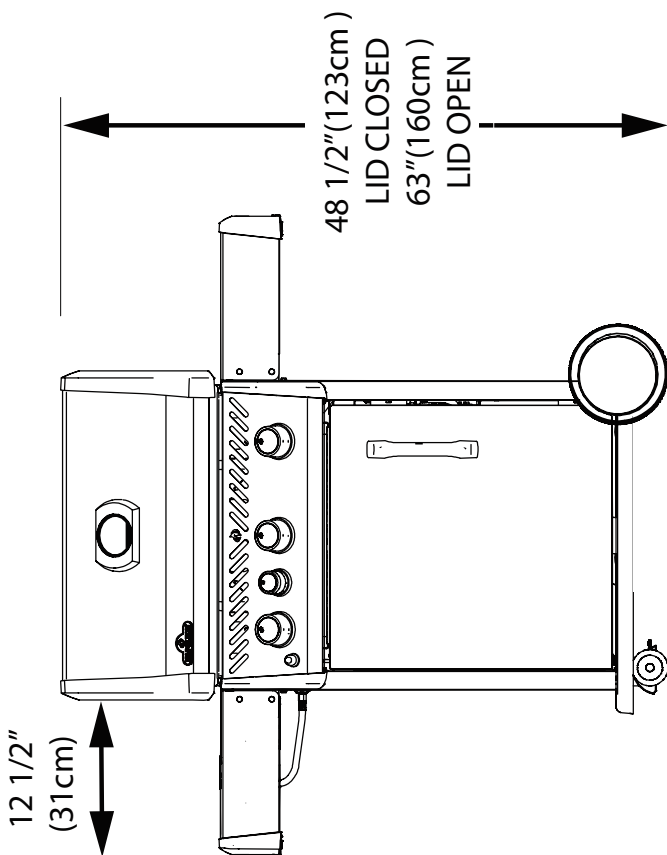
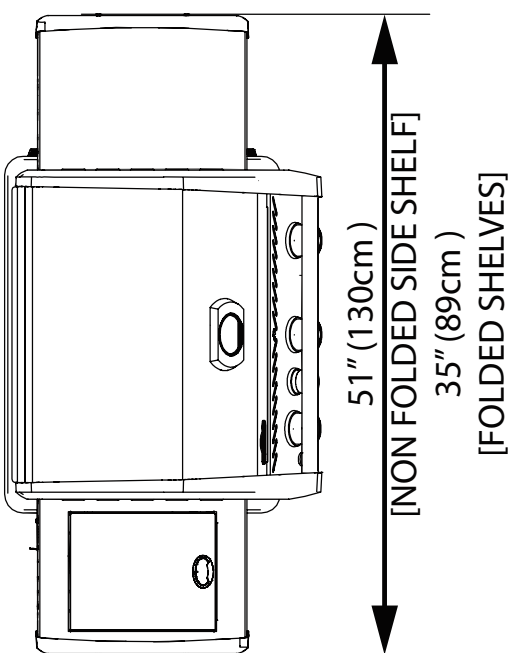

ORIFICE SIZES	
	ULPG
MAIN BURNER	#58
REAR BURNER	1.15 mm
SIDE BURNER	#65



DIMENSIONS

RXT525SB-1 AU GRILL

- 4 x 12.7 MJ/h MAIN BURNER
- 1 x 9.5 MJ/h SIDE BURNER (IF EQUIPPED)

GRILL SIZE: 18" X 28.75" = 525 in²
 WARMING RACK SIZE: 6.5" X 28.5" = 186 in²
 SIDE BURNER SIZE: 9.5" X 11.25" = 107 in²

ALL DIMENSIONS ARE APPROXIMATE

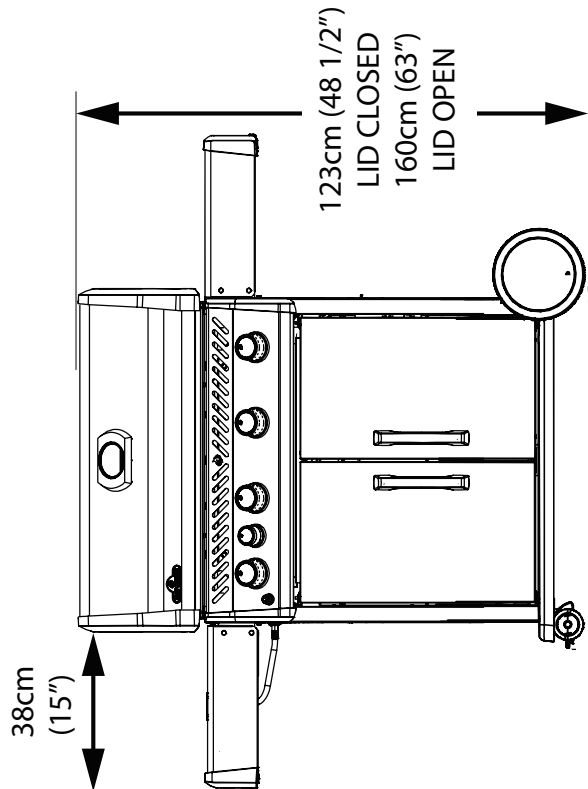
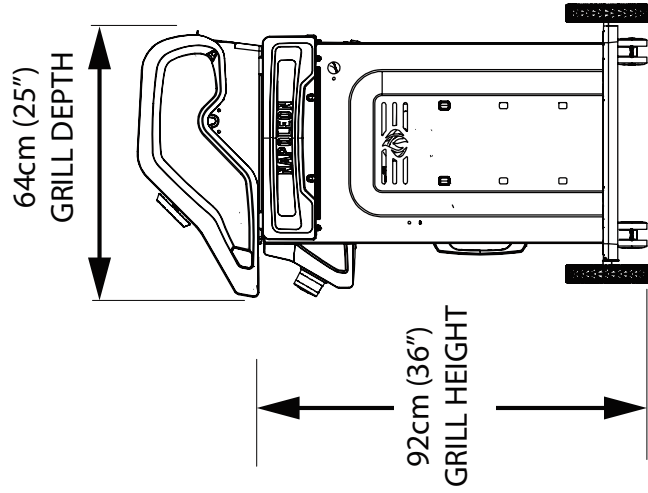
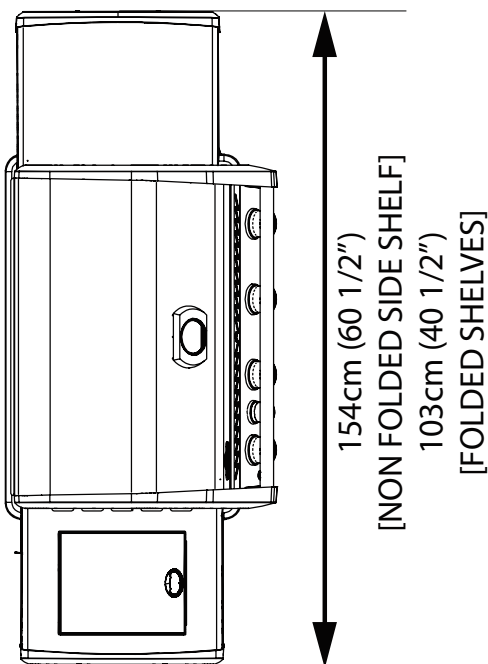

ORIFICE SIZES	
	ULPG
MAIN BURNER	#60
REAR BURNER	1.15 mm
SIDE BURNER	#65



DIMENSIONS

RXT625SB-1 AU GRILL

5 x 12.7 MJ/h MAIN BURNER
1 x 9.5 MJ/h SIDE BURNER (IF EQUIPPED)

GRILL SIZE: 18" X 34.75" = 625 in²
WARMING RACK SIZE: 6.5" X 34.25" = 223 in²
SIDE BURNER SIZE: 9.5" X 11.25" = 107 in²

ALL DIMENSIONS ARE APPROXIMATE

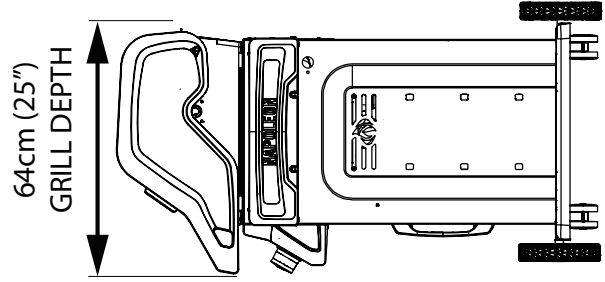
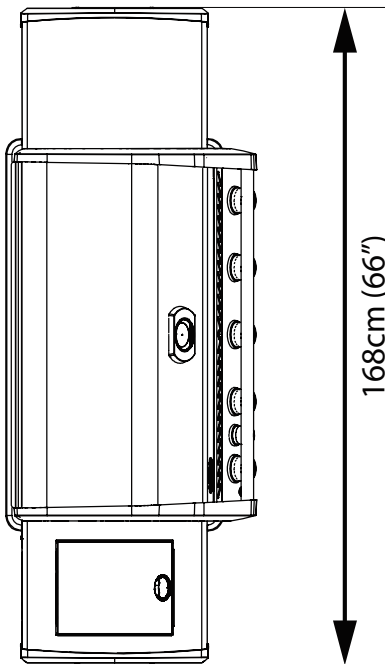

ORIFICE SIZES	
	ULPG
MAIN BURNER	#60
REAR BURNER	1.15 mm
SIDE BURNER	#65

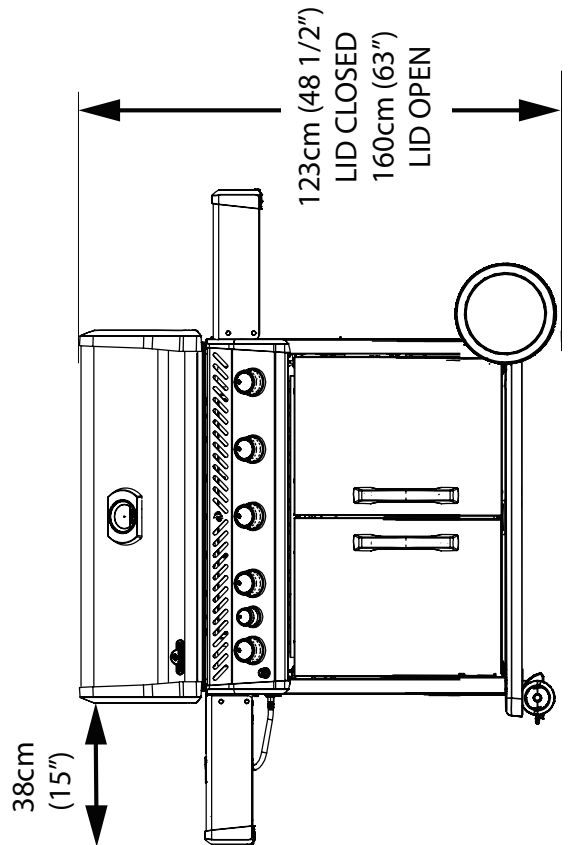

General Information

This gas grill is certified for outdoor use and should be installed in conformity with AS/NZS 5601 and local codes. Check gas type and specifications located on the rating plate located on the back panel of the grill.

Universal Liquefied Petroleum Gas Cylinder Specifications



WARNING! If these instructions are not followed exactly, a fire causing death or serious injury may occur.
WARNING! Do not store a spare ULPG cylinder on the shelf beneath the barbecue.

This gas grill has been designed for use with an approved 9 kg size Universal Liquefied Petroleum Gas cylinder (not supplied). The Universal Liquefied Petroleum Gas cylinder must be equipped with a POL tank valve connection. A dented or rusty cylinder may be hazardous and should be checked by your Universal Liquefied Petroleum Gas supplier. Never use a cylinder with a damaged valve. The cylinder supply system must be arranged for vapor withdrawal and the cylinder shall include a dust cap to protect the cylinder valve. The cylinder shall incorporate a listed OPD (overfill protection device). Do not store a spare Universal Liquefied Petroleum Gas cylinder under or near this appliance. Never fill the cylinder beyond 80 percent full.

Gas Hook-Up Instructions



WARNING! A fire will result if the gas supply hose makes contact with the underside of the grill or drip pan.

Cylinder Installation: Check that the cylinder valve is closed by turning the knob clockwise. Check that the grill's burner knobs are in the off position. Open cabinet doors. Set cylinder into hole in bottom shelf. Place the cylinder so that the valve faces toward the front of the grill. Other cylinders may be acceptable provided they fit properly into the tank retaining ring.

Cylinder Connection: Ensure the gas regulator hose is kink free. Remove the cap or plug from the cylinder fuel valve. Insert the POL regulator nipple onto the fuel valve. Hand tighten counter clockwise. Do not use tools. Leak test all joints prior to using the grill. A leak test must be performed annually and each time a cylinder is hooked up or if a part of the gas system is replaced.

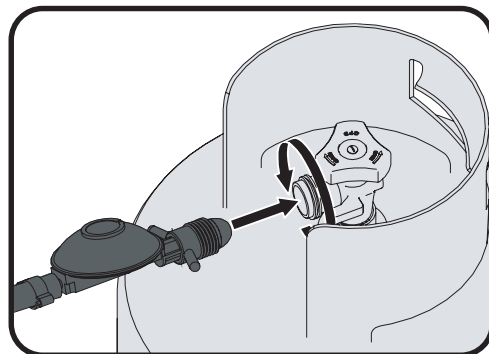
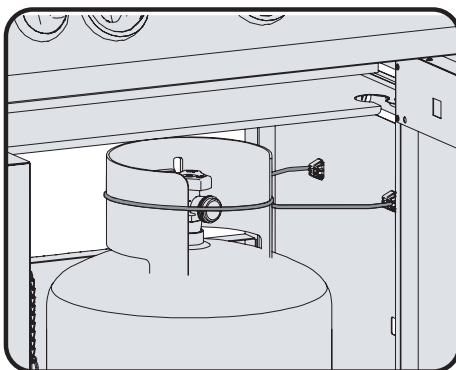
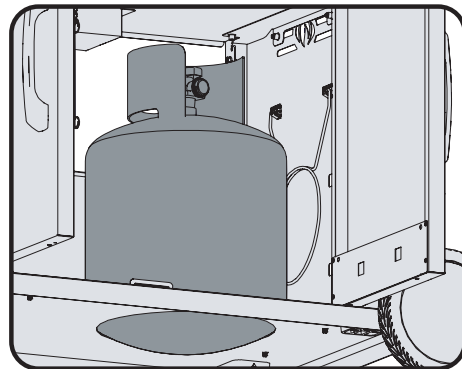
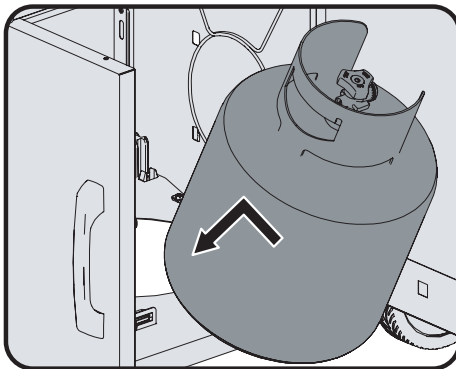

Leak Testing Instructions



WARNING! A leak test must be performed annually and each time a cylinder is hooked up or if a part of the gas system is replaced.



WARNING! Never use an open flame to check for gas leaks. Be certain no sparks or open flames are in the area while you check for leaks. Sparks or open flames will result in a fire or explosion, damage to property, serious bodily injury, or death.



Leak testing: This must be done before initial use, annually, and whenever any gas components are replaced or serviced. Do not smoke while performing this test, and remove all sources of ignition. See Leak Testing Diagram for areas to check. Turn all burner controls to the off position. Turn gas supply valve on.



Brush a half-and-half solution of liquid soap and water onto all joints and connections of the regulator, hose, manifolds and valves.



Bubbles will indicate a gas leak. Either tighten the loose joint or have the part replaced with one recommended by the Napoleon Customer Solutions department and have the grill inspected by a certified gas installer.

If the leak cannot be stopped, **immediately shut off the gas supply**, disconnect it, and have the grill inspected by a certified gas installer or dealer. Do not use the grill until the leak has been corrected.

Lighting Instructions

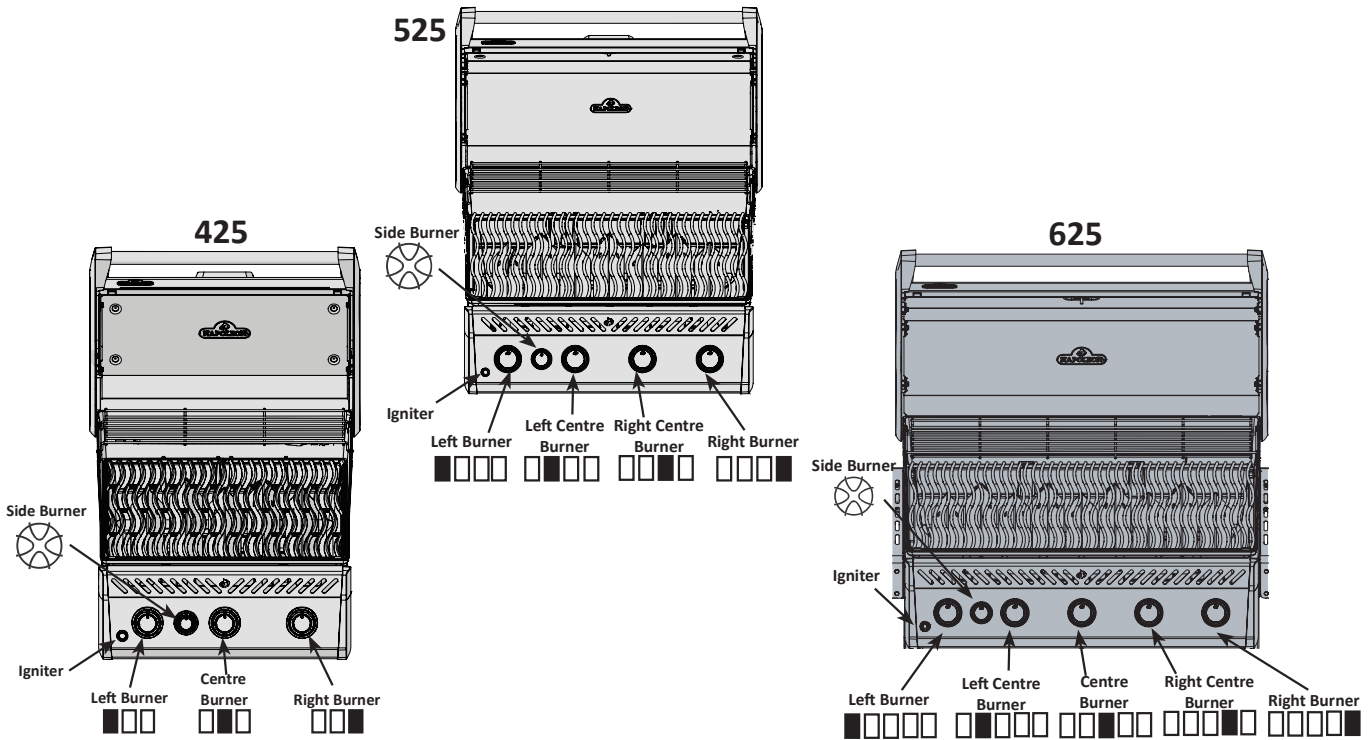

WARNING! Open lid

WARNING! Ensure all burner controls are in the off position. Slowly turn on the gas supply valve.

Off Position

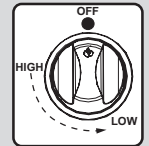

Main Burner Lighting	Side Burner Lighting (if equipped)
1. Open grill lid	1. Open burner cover.
2. Push and turn any main burner knob slowly to the high position. If the pilot lights, continue to push down on the control knob until the burner lights and then release.	2. Turn side burner control to high position.
3. If the pilot does not ignite, then immediately turn the control knob back to the 'off' position and repeat step 2 several times.	3. Press and hold igniter button until burner lights, or light by match.
4. If the pilot and burner will not ignite within 5 seconds, turn the control knob to the 'off' position and wait 5 minutes for any excess gas to dissipate. Either repeat steps 2 and 3 or light with a match.	4. If ignition is not immediate, turn burner control off. Wait 5 minutes. Repeat.
5. If lighting the unit with a match, clip the match into the supplied lighting rod. Hold the lit match down through the grill and sear plate while turning the corresponding burner valve to high.	



NOTE! Do not use rear burner while operating main burner.

Cooking Instructions

Initial Lighting: When lit for the first time, the gas grill emits a slight odor. This is a normal temporary condition caused by the “burn-in” of internal paints and lubricants used in the manufacturing process and does not occur again. Simply run the main burners on high for approximately one-half hour.

Main Burner Use: When searing foods, the lid must be kept open and the burners can be set to high. If cooking with the lid closed, preheat grill on high for 10 minutes with the lid closed, and then turn the main burners to low. Food cooked for short periods of time (fish, vegetables) can be grilled with the lid open. Cooking with the lid closed will ensure higher, more even temperatures that can reduce cooking time and cook meat more evenly. Food that has a cooking time longer than 30 minutes, such as roasts, can be cooked indirectly (with the burner lit opposite to the food placement). When cooking very lean meats, such as chicken breasts or lean pork, the grids can be oiled before pre-heating to reduce sticking. Cooking meat with a high degree of fat content can create flare-ups. Either trim the fat or reduce temperatures to inhibit this. Should a flare-up occur, move food away from the flames and reduce the heat. Leave the lid open. See *Your All Season Grill* cookbook by Napoleon for more detailed instructions.

Direct Cooking: Place food to be cooked on the grill directly over the heat. This method is generally used for searing or for foods that do not require prolonged cooking times such as hamburgers, steaks, chicken pieces, or vegetables. The food is first seared to trap-in the juices and flavor, and then the temperature is lowered to finish cooking the food to your preference.

Indirect Cooking: With one or more burners operating, place food to be cooked on the grill over a burner that is not operating. The heat circulates around the food, cooking slowly and evenly. Cooking with this method is much the same as cooking in your oven and is generally used for larger cuts of meats such as roasts, chickens or turkeys, but can also be used for cooking foods that are prone to flare-ups or for smoking foods. Lower temperatures and slower cooking times result in tender foods.

Flame Side Burner Use (if equipped): The side burner can be used like any stove top burner, for gravies, soups etc. For best performance, the gas grill should be located with the side burner protected from the wind. Select cookware that is between 16cm (6.3”) and 24cm (9.4”) in diameter. The cookware should be placed over the centre of the burner, unless this positioning causes the handle to extend directly over the flames. Always turn the handle to the side or back of the grill to reduce the risk of knocking the cookware off the side shelf.



WARNING! Never grill food directly on the side burner grate. It is designed for use with pots and pans only.

WARNING! Do not close the side burner lid while it is operating or hot.

WARNING! Do not use side burner to deep fry foods as cooking with oil can create a dangerous situation.

Cleaning Instructions



WARNING! Always wear protective gloves and safety glasses when servicing your grill.

WARNING! To avoid the possibility of burns, maintenance should be done only when the grill is cool. Avoid unprotected contact with hot surfaces. Ensure all burners are turned off. Clean grill in an area where cleaning solutions will not harm decks, lawns, or patios. Do not use oven cleaner to clean any part of this gas grill. Do not use a self-cleaning oven to clean cooking grids or any other parts of the gas grill. Barbecue sauce and salt can be corrosive and will cause rapid deterioration of the gas grill components unless cleaned regularly.

Note: Stainless steel tends to oxidize or stain in the presence of chlorides and sulfides, particularly in coastal areas and other harsh environments, such as the warm, highly humid atmosphere around pools and hot tubs. These stains could be perceived as rust, but can be easily removed or prevented. To provide stain prevention and removal, wash all stainless steel and chrome surfaces every 3-4 weeks or as often as required with fresh water and/or stainless steel cleaner.

Grids And Warming Rack: The grids and warming rack are best cleaned with a brass wire brush during the pre-heating period. Steel wool can be used for stubborn stains. It is normal that stainless grids (if equipped) will discolor permanently from regular usage due to the high temperature of the cooking surface.

Cast Iron Cooking Grids: The cast iron cooking grids supplied with your new grill offer superior heat retention and distribution. By regularly seasoning your grids you are adding a protective coating, which will aid in resisting corrosion and increase your grids non-stick capabilities.

First Time Use: Wash the cooking grids by hand with mild dish soap and water to remove any residue from the manufacturing process (never wash in a dishwasher). Rinse thoroughly with hot water and dry completely with a soft cloth. This is important to avoid moisture from entering the cast iron.

Seasoning: Using a soft cloth, spread VEGETABLE SHORTENING over the entire grid surface ensuring all grooves and corners are covered. Do not use salted fats such as butter or margarine. Pre-heat your grill for 15 minutes, then place the seasoned cooking grids in the grill. Turn the burner control knobs to medium with the lid closed. Allow the cooking grids to heat for approximately one-half hour. Turn all the burners to the "OFF" position and turn the gas off at the source. Let the cooking grids stand until cool. This procedure should be repeated several times throughout the season, although it is not required for daily use (follow daily usage procedure below).

Daily Usage: Before pre-heating, and cleaning with a brass wire grill brush, coat the entire top surface of the cooking grids with VEGETABLE SHORTENING. Pre-heat the grill and then brush away any unwanted residue with a brass wire brush.

Stainless Steel Cooking Grids: (upgrade kit available - see replacement parts list). Stainless steel cooking grids are durable and corrosion resistant. They require less seasoning and maintenance than cast iron cooking grids. It is recommended that you follow the daily usage procedure listed above although you may find pre-heating and cleaning your grids with a wire brush is sufficient for your grilling needs.

Control Panel: The control panel text is printed directly on the stainless steel and with proper maintenance will remain dark and legible. To clean the panel, use only warm soapy water. Never apply abrasive cleaners on any stainless surfaces, especially the printed portion of the control panel or the printing will gradually rub off.

Cleaning Inside The Gas Grill: Remove the cooking grids. Use a brass wire brush to clean loose debris from the casting sides and underneath the lid. Scrape the sear plates with a putty knife or scraper, and use a wire brush to remove the ash. Remove the sear plates and brush debris from the burners with the brass wire brush. Sweep all debris from inside the gas grill into the drip pan.



WARNING! Accumulated grease is a fire hazard.

Drip Pan: Clean the drip pan frequently (every 4 – 5 uses or as often as required) to avoid grease buildup. Grease and excess drippings pass through to the drip pan, located beneath the gas grill and accumulate in the disposable grease tray below the drip pan. To access the disposable grease tray or to clean the drip pan, slide the drip pan free of the grill. Never line the drip pan with aluminum foil, sand or any other material as this could prevent the grease from flowing properly. The pan should be scraped out with a putty knife or scraper. Replace the disposable grease tray every 2 – 4 weeks, depending on gas grill usage. For supplies, see your Napoleon Grill dealer.

Cleaning The Outer Grill Surface: Do not use abrasive cleaners or steel wool on any painted, porcelain or stainless steel parts of your Napoleon Grill. Doing so will scratch the finish. Exterior grill surfaces should be cleaned with warm soapy water while the metal is still warm to the touch. To clean stainless surfaces, use a stainless steel or a non-abrasive cleaner. Always wipe in the direction of the grain. Over time, stainless steel parts discolor when heated, usually to a golden or brown hue. This discoloration is normal and does not affect the performance of the grill. Porcelain enamel components must be handled with additional care. The baked-on enamel finish is glass-like, and will chip if struck. Touch-up enamel is available from your Napoleon Grill dealer.

Maintenance Instructions

We recommend this gas grill be thoroughly inspected and serviced annually by a qualified service person.

At all times keep the gas grill area free from combustible materials, gasoline and other flammable vapors and liquids. Do not obstruct the flow of ventilation and combustion air. Keep the cylinder enclosure ventilation openings (located on the cart sides and at the front and back of the bottom shelf) free and clear from debris.



WARNING! Always wear protective gloves and safety glasses when cleaning your grill.



WARNING! Turn off the gas at the source and disconnect the unit before servicing. To avoid the possibility of burns, maintenance should be done only when the grill is cool. A leak test must be performed annually and whenever any component of the gas train is replaced or gas smell is present.



Combustion Air Adjustment: (This must be done by a qualified gas installer.) The air shutter is factory set and should not need adjusting under normal conditions. Under extreme field conditions, adjustments might be required. When the air shutter is adjusted correctly the flames will be dark blue, tipped with light blue and occasionally yellow.

With too little air flow to the burner, the flames are lazy yellow and can produce soot.

With too much air flow, the flames lift erratically and can cause difficulties when lighting.

Adjusting the air shutter:

1. Remove cooking grids and sear plates and leave lid open. You may have to open the door or remove the top drawer (if equipped) to access the air-shutter screw located at the mouth of the burner. The back cover must be removed for rear tube burner air shutter adjustment.
2. Loosen air-shutter lock screw and open or close air shutter as required. The normal opening settings are:

Main Tube Burner

ULPG 9/16" (14.3mm)

3. Light the burners and set to high. Visually inspect burner flames. When the shutters are set correctly, turn burners off, tighten locking screws, and replace removed parts. Ensure that the insect screens are installed.

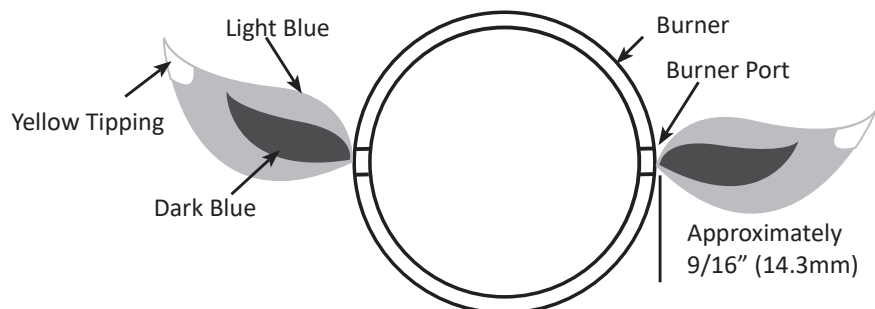



Burner: The burner is made from heavy wall 304 stainless steel, but extreme heat and a corrosive environment can cause surface corrosion to occur. This can be removed with a brass wire brush.

CAUTION! Beware of Spiders.

Spiders and insects are attracted to the smell of Universal Liquefied Petroleum Gas (ULPG). The burner is equipped with an insect screen on the air shutter, which reduces the likelihood of insects building nests inside the burner but does not entirely eliminate the problem. A nest or web can cause the burner to burn with a soft yellow or orange flame or cause a fire (flashback) at the air shutter underneath the control panel. To clean the inside of the burner, it must be removed from the gas grill: Remove the screw (s) that attaches the burner to the back wall. Slide the burner back and up wards to remove. Cleaning: Use a flexible venturi tube brush to clean the inside of the burner. Shake any loose debris from the burner through the gas inlet. Check the burner ports and valve orifices for blockages. Burner ports can close over time due to cooking debris and corrosion, use an opened paperclip or the supplied port maintenance bit to clean them. Drill out blocked ports using this drill bit in a small cordless drill. The ports are easier to clean if the burner is removed from the grill, but it can also be done with the burner installed. Do not flex the drill bit when drilling the ports, as this will cause the drill bit to break. This drill is for burner ports only, not for the brass orifices (jets) which regulate the flow into the burner. Take care not to enlarge the holes. Ensure the insect screen is clean, tight, and free of any lint or other debris.

Reinstallation: Reverse the procedure to reinstall the burner. Check that the valve enters the burner when installing. Replace sear plate mount and / or tighten screws to complete reinstallation.



WARNING! When reinstalling the burner after cleaning it is very important that the valve/orifice enters the burner tube before lighting your gas grill. If the valve is not inside the burner tube a fire or explosion could occur.

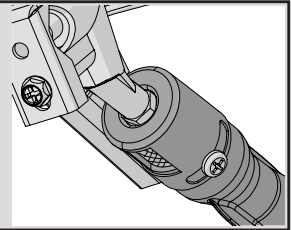

CAUTION! Check for abrasions, melting, cuts, and cracks in the hose. If any of these conditions exist, do not use the gas grill. Have the part replaced by your Napoleon Grill dealer or qualified gas installer.

Aluminum Castings: Clean castings periodically with warm soapy water. Aluminum will not rust, but high temperatures and weathering can cause oxidation to occur on aluminum surfaces. This appears as white spots on the castings. To refinish these areas, clean first and sand lightly with fine sandpaper. Wipe the surface to remove any residue and paint with high temperature barbecue paint. Protect surrounding areas from over-spray. Follow the manufacture’s directions for curing.

Troubleshooting

Problem	Possible Causes	Solution
Low heat / Low flame when valve turned to high.	Improper lighting procedure.	Ensure lighting procedure is followed carefully. All gas grill valves must be in the off position when the tank valve is turned on. Turn tank on slowly to allow pressure to equalize. See lighting instructions.
	Improper preheating.	Pipe must be sized according to installation code. Preheat grill with main burners on high for 10 minutes.



Problem	Possible Causes	Solution
Excessive flare-ups/ uneven heat.	Sear plates installed incorrectly. Improper preheating. Excessive grease and ash build on sear plates and in drip pan.	Ensure sear plates are installed with the holes towards the front and the slots on the bottom. See assembly instructions. Preheat grill with main burners on high for 10 minutes. Clean sear plates and drip pan regularly. Do not line pan with aluminum foil. Refer to cleaning instructions.
Burners burn with yellow flame, accompanied by the smell of gas.	Possible spider web or other debris, or improper air shutter adjustment.	Thoroughly clean burner by removing. See general maintenance instructions. Open air shutter slightly according to combustion air adjustment instructions. (This must be done by a qualified gas installer.)
Flames lift away from burner, accompanied by the smell of gas, and possibly difficulties in lighting.	Improper air shutter adjustment.	Close air shutter slightly according to combustion air adjustment instructions. (This must be done by a qualified gas installer.)
Main burner will not light with the igniter but will light with a match.	Jet-fire outlet is dirty or clogged.	Clean jet-fire outlet with a soft bristle brush.
Humming regulator.	Normal occurrence on hot days.	This is not a defect. It is caused by internal vibrations in the regulator and does not affect the performance or safety of the gas grill. Humming regulators will not be replaced.
Burners will not cross light each other.	Dirty or corroded cross light brackets.	Clean or replace as required.
"Paint" appears to be peeling inside lid or hood.	Grease build-up on inside surfaces.	This is not a defect. The finish on the lid and hood is porcelain and will not peel. The peeling is caused by hardened grease, which dries into paint-like shards, that flake off. Regular cleaning will prevent this. See cleaning instructions.
Burner output on "high" setting is too low. (Rumbling noise and fluttering blue flame at burner surface.)	Lack of gas. Supply hose is pinched. Dirty or clogged orifice. Spider webs or other matter in venturi tube. ULPG regulator in "low flow" state.	Check gas level in ULPG cylinder. Reposition supply hose as necessary. Clean burner orifice. Clean out venturi tube. Ensure lighting procedure is followed carefully. All gas grill valves must be in the off position when the tank valve is turned on. Turn tank on slowly to allow pressure to equalize. See lighting instructions.

KEEP YOUR RECEIPT AS PROOF OF PURCHASE TO VALIDATE YOUR WARRANTY.

Ordering Replacement Parts

Warranty Information

MODEL: _____

DATE OF PURCHASE: _____

SERIAL NUMBER: _____

(Record information here for easy reference)

For replacement parts and warranty claims, contact the Napoleon dealer where the product was purchased.

Before contacting the dealer, check the Napoleon Grills Website for more extensive cleaning, maintenance, troubleshooting and parts replacement instructions at www.napoleon.com.

To process a claim, the following information is required:

1. Model and serial number of the unit.
2. Part number and description.
3. A concise description of the problem ('broken' is not sufficient).
4. Proof of purchase (photocopy of the invoice).

In some cases, Napoleon could request to have the parts returned to the factory for inspection before providing replacement parts.

Before contacting Napoleon dealer, please note that the following items are not covered by the warranty:

- Costs for transportation, brokerage or export duties.
- Labour costs for removal and reinstallation.
- Costs for service calls to diagnose problems.
- Discolouration of stainless steel parts.
- Part failure due to lack of cleaning and maintenance, or use of improper cleaners (oven cleaner or other harsh chemicals).



CAUTION! During unpacking and assembly we recommended you wear work gloves and safety glasses for your protection. Although we make every effort to make the assembly process as problem free and safe as possible, it is characteristic of fabricated steel parts that the edges and corners might be sharp and could cause cuts if handled incorrectly.

Getting Started

1. Remove all cart panels, hardware, and grill head from carton. Raise lid and remove any components packed inside. Use the parts list to ensure all necessary parts are included.
2. Do not destroy packaging until the grill has been fully assembled and operates to your satisfaction.
3. Assemble the grill where it is to be used, lay down cardboard or a towel to protect parts from being lost or damaged while assembling.
4. **Most stainless steel parts are supplied with a protective plastic coating that must be removed prior to using the grill. The protective coating has been removed from some of the parts during the manufacturing process and may have left behind a residue that can be perceived as scratches or blemishes. To remove the residue, vigorously wipe the stainless steel in the same direction as the grain.**
5. Follow all instructions in the order that they are laid out in this manual.
6. Two people are required to lift the grill head onto the assembled cart.



If you have any questions about assembly or grill operation, or if there are damaged or missing parts please call our Customer Solutions Department at 1-866-820-8686 between 9 AM and 5 PM (Eastern Standard Time).

TOOLS REQUIRED FOR ASSEMBLY (tools not included)

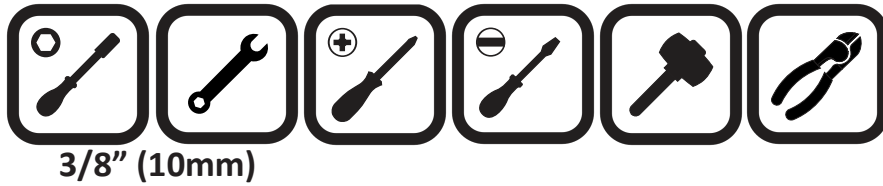

ULPG – Proper Hose Connection



WARNING! Ensure the hose does not contact any high temperature surfaces, or it may melt and leak causing a fire.



WARNING! Clip hose to cart heat shield using bushing supplied. Failure to follow these instructions could result in property damage, personal injury or death.

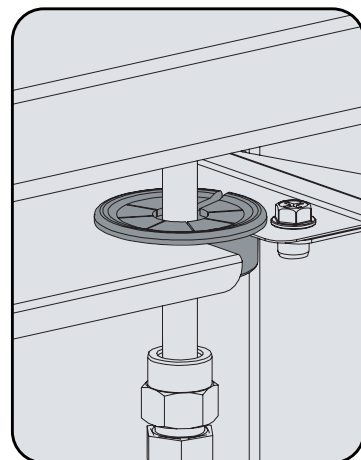



WARNING – FIRE HAZARD



WARNING! Do not route hose underneath drip pan.

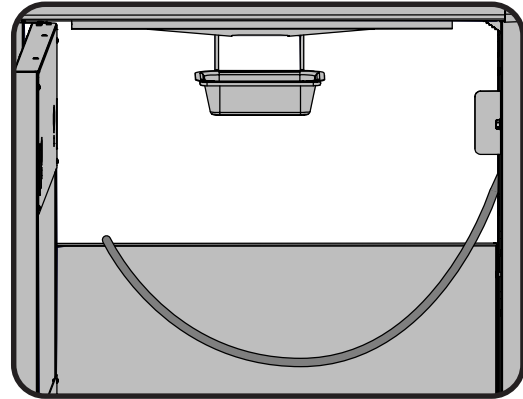
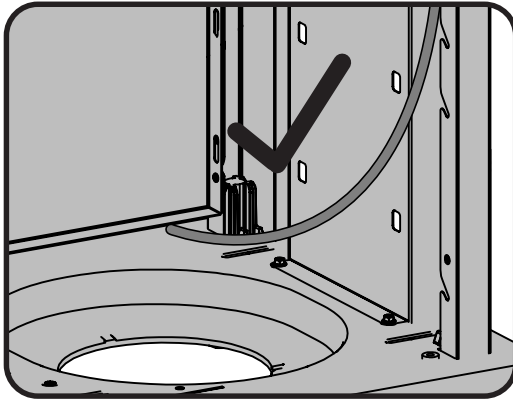

WARNING! Ensure the hose does not contact any high temperature surfaces, or it may melt and leak causing a fire.



Leak Testing Instructions



WARNING! A leak test must be performed annually and each time a cylinder is hooked up or if a part of the gas system is replaced.



WARNING! Never use an open flame to check for gas leaks. Be certain no sparks or open flames are in the area while you check for leaks. Sparks or open flames will result in a fire or explosion, damage to property, serious bodily injury, or death.



Leak testing: This must be done before initial use, annually, and whenever any gas components are replaced or serviced. Do not smoke while performing this test, and remove all sources of ignition. See Leak Testing Diagram for areas to check. Turn all burner controls to the off position. Turn gas supply valve on.



Brush a half-and-half solution of liquid soap and water onto all joints and connections of the regulator, hose, manifolds and valves.



Bubbles will indicate a gas leak. Either tighten the loose joint or have the part replaced with one recommended by the Napoleon Customer Solutions department and have the grill inspected by a certified gas installer.

If the leak cannot be stopped, **immediately shut off the gas supply**, disconnect it, and have the grill inspected by a certified gas installer or dealer. Do not use the grill until the leak has been corrected.

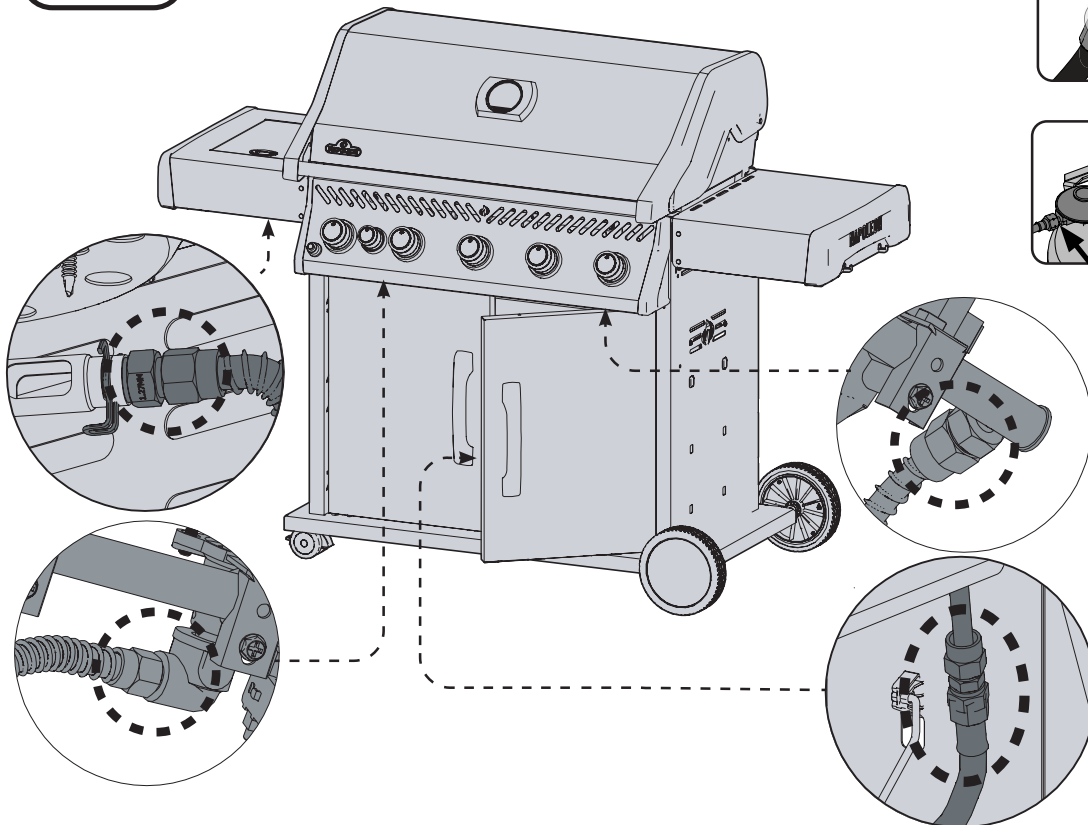
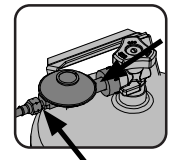
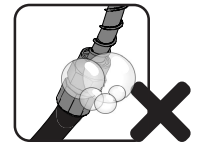
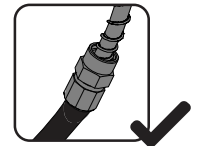

PARTS LIST

	Part Number	Description	RXT425	RXT525	RXT625
1	N010-1031-BK	lid assembly	x		
	N010-1034-BK	lid assembly		x	
	N010-1233-BK	lid assembly			x
2	S91003	temperature gauge	x	x	x
3	N385-0307-SER	logo	x	x	x
4	N510-0013	lid bumper	x	x	x
5	S87014	lid pivot hardware	x	x	x
6	S87010	crosslight bracket	x		
	S87013	crosslight bracket		x	
	S87017	crosslight bracket			x
7	S87001	burner and sear plate	x	x	x
8	N010-1523-SER	control panel assembly	p		
	N010-1524-SER	control panel assembly		p	
	N010-1525-SER	control panel assembly			p
9	N475-0572-BK1GL	control panel	x		
	N475-0585-BK1GL	control panel		x	
	N475-0586-BK1GL	control panel			x
10	S86002	1-spark igniter	x	x	x
11	N380-0044	small knob	x	x	x
12	N380-0043	large knob	x	x	x
13	N010-1184	manifold assembly	x		
	N010-0982	manifold assembly		x	
	N010-1215	manifold assembly			x
14	N520-0050	warming rack	x		
	N520-0049	warming rack		x	
	N520-0048	warming rack			x
15	N010-1041-SER	base assembly	x		
	N010-0999-SER	base assembly		x	
	N010-1280-SER	base assembly			x
16	N305-0096	stainless steel main cooking grid	x	x	x
	N305-0113	stainless steel 525 center cooking grid		x	
17	N200-0118-GY1SG	base back cover	x		
	N200-0127-GY1SG	base back cover		x	
	N200-0135-GY1SG	base back cover			x
18	N475-0363-GY1SG	rear cart panel	x		
	N475-0449-GY1SG	rear cart panel		x	
	N475-0499-GY1SG	rear cart panel			x
19	N585-0138-GY1SG	heat shield	x		
	N585-0139-GY1SG	heat shield		x	
	N585-0140-GY1SG	heat shield			x
20	N080-0437-GY1SG	heat shield bracket left/right	x	x	x
21	N570-0126	1/4-20 x 1/2" screw	x	x	x
22	N080-0364	folding bracket "A"	x	x	x

PARTS LIST

	Part Number	Description	RXT425	RXT525	RXT625
23	N010-1526-SER	side shelf assembly	x	x	x
24	N710-0062	grease tray	x	x	x
	62007	grease tray liners (5pc)	ac	ac	ac
25	N200-0134-GY1SG	grease tray cover	x	x	x
26	N080-0365	folding bracket "B"	x	x	x
27	N370-0928-SER	side shelf pivot hardware	x	x	x
28	N475-0356-GY1SG	side panel left/right	x	x	x
29	N590-0318-GY1SG	bottom shelf	x		
	N590-0319-GY1SG	bottom shelf		x	
	N590-0320-GY1SG	bottom shelf			x
30	N160-0034-GY1SG	propane tank retainer	p	p	p
31	N160-0035	retainer ring clip	p	p	p
32	N015-0012	axle	x	x	x
33	N450-0023	plastic cap nut	x	x	x
34	N120-0037	wheel hub cap	x	x	x
35	N745-0009	wheel	x	x	x
36	N430-0002	magnet	x	x	x
37	N080-0387-GY1SG	magnet bracket		x	x
38	N570-0118	1/4-20 x 3/8" screw	x	x	x
39	N735-0027	washer 1/2"	x	x	x
40	S82001	caster	x	x	x
41	N510-0015	caster plug	x	x	x
42	N555-0097	lighting rod	x	x	x
43	N010-0869-BK-SER	black door assembly	x		
	N010-0984-BK-SER	black door assembly		x	
	N010-1221-BK-SER	black door assembly			x
44	N105-0011	door bushing	x	x	x
45	N325-0094-SER	door handle	x	x	x
46	N080-0380-GY1SG	door magnet bracket	x		
47	N080-0254G	tank inhibitor bracket		p	
48	N590-0327-GY1SG	tank inhibitor shelf			x
49	N080-0378-GY1SG	door pivot bracket	x	x	x
50	N105-0020	flex line bushing	x	x	x
51	N450-0053	shelf lock nut	x	x	x
52	N750-0016	side burner electrode	x	x	x
53	N105-0017	side burner hose bushing	x	x	x
54	Z255-0002-1	side burner fitting	x	x	x
55	N720-0079	flex hose	x	x	x
56	N160-0023	side burner orifice clip	x	x	x
57	N345-0021	side burner supply hose	x	x	x
58	N455-0085	side burner orifice	p	p	p
59	N010-1527-SER	flame side burner shelf assembly	x	x	x
60	Z580-0003	lid pivot rod	x	x	x

PARTS LIST

	Part Number	Description	RXT425	RXT525	RXT625
61	Z485-0001	clevis pin	x	x	x
62	N335-0099-BK1HR	side burner lid	x	x	x
63	Z325-0013	side burner lid handle	x	x	x
64	Z305-0008	side burner grate	x	x	x
65	Z100-0002	side burner	x	x	x
66	N010-1516-BK1HR	side shelf	x	x	x
67	Z710-0004	side burner plate	x	x	x
68	N530-0048	regulator	p	p	p
69	N710-0094	drip pan	x		
	N710-0108	drip pan		x	
	N710-0120	drip pan			x
70	56425	cast iron griddle	x	x	x
	62050	jetfire and burner maintenance kit	x	x	x
	69914	roisserie kit	ac	ac	ac
	61427	425 cover	ac		
	61527	525 cover		ac	
	61627	625 cover			ac
	S82002	premium caster kit	ac	ac	ac
	67732	charcoal tray	ac	ac	ac
	62007	grease tray liners (5pc)	ac	ac	ac
	S83013	stainless steel cooking grids	ac		
	S83008	cast iron cooking grids	ac		
	S83023	stainless steel cooking grids		ac	
	S83024	cast iron cooking grids		ac	
	S83022	stainless steel cooking grids			ac
	S83021	cast iron cooking grids			ac

x - standard
ac - accessory

p - propane units only
sp -special edition

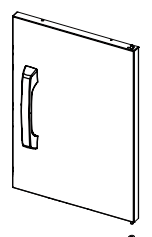
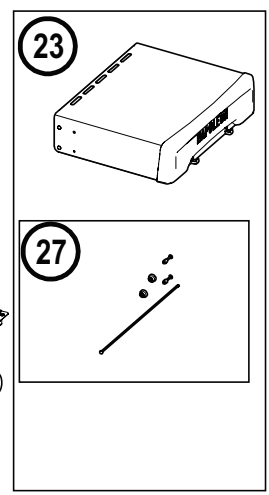
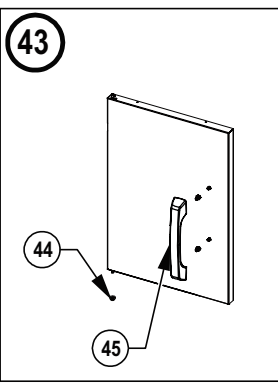
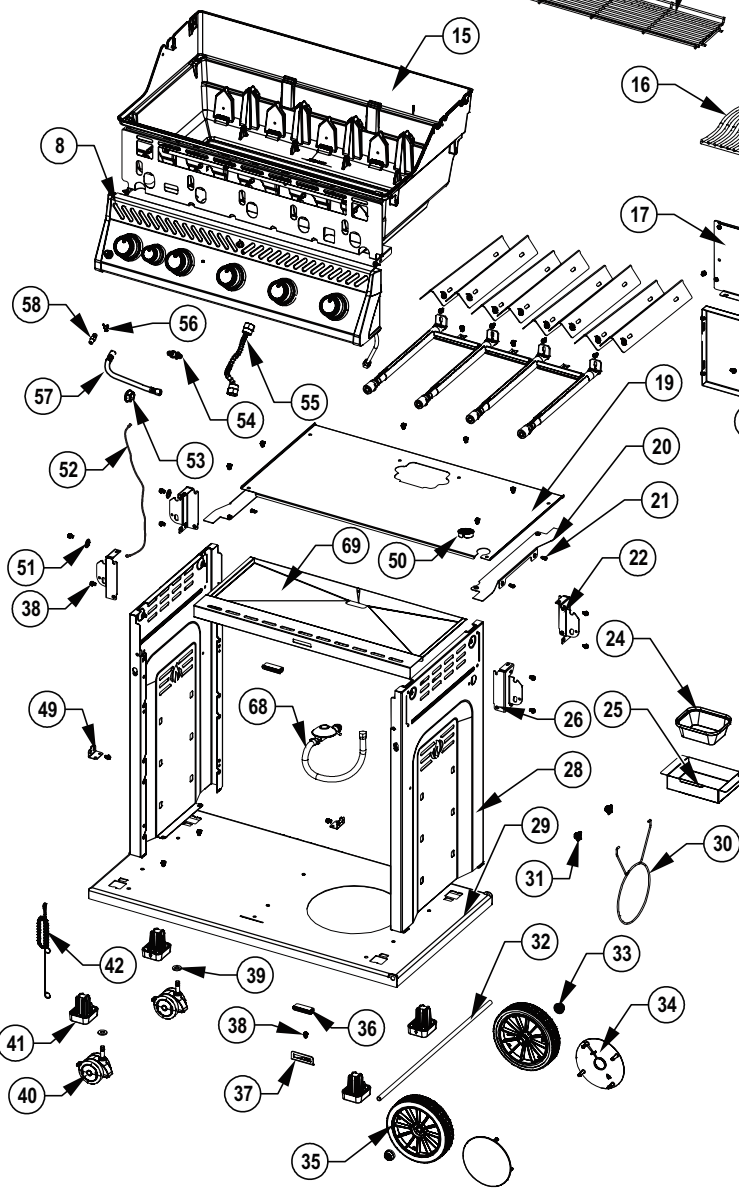
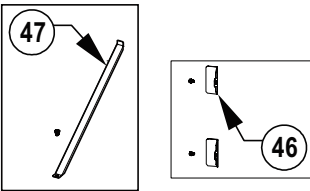
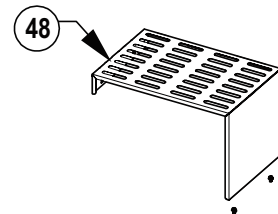
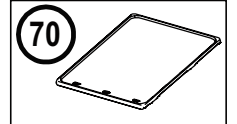
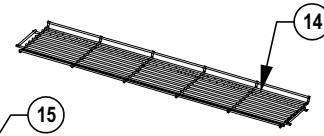
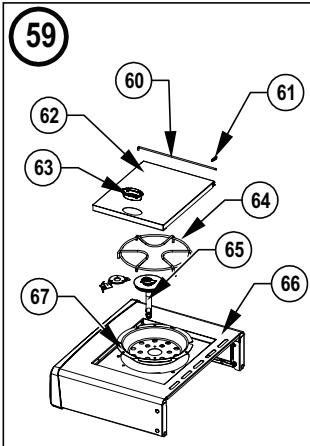
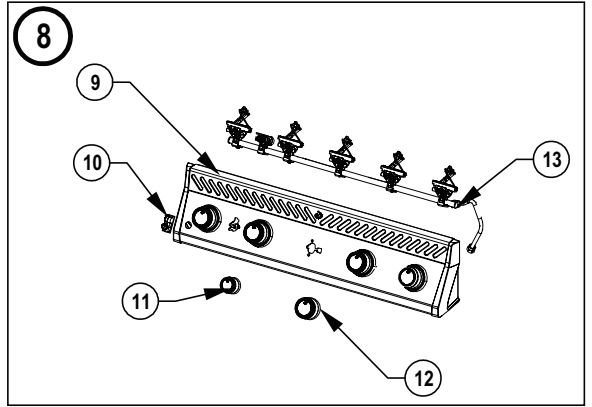
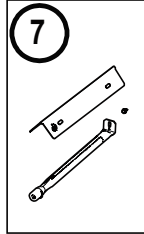
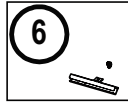
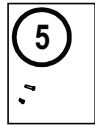
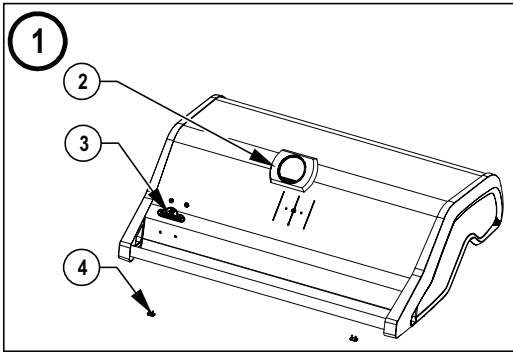



Napoleon products are protected by one or more U.S. and Canadian and/or foreign patents or patents pending.

www.napoleon.com

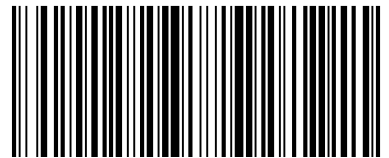

N415-0705-AU