

RUSH[®] MH 11 Beam

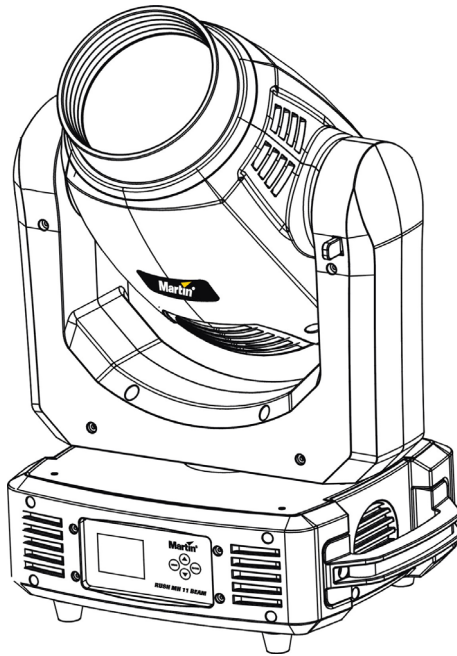

User Manual

Martin[®]
by HARMAN

Information subject to change without notice. HARMAN Professional Denmark ApS disclaims liability for any injury, damage, direct or indirect loss, consequential or economic loss or any other loss occasioned by the use of, inability to use or reliance on the information contained in this document.

©2017 HARMAN Professional Denmark ApS. All rights reserved. Martin® and RUSH® are registered trademarks of HARMAN Professional Denmark ApS registered in the United States and/or other countries. Features, specifications, and appearance are subject to change without notice.

Martin Professional • Olof Palmes Allé 18 • 8200 Aarhus N • Denmark • www.martin.com

RUSH® MH 11 Beam User Manual: Revision C

Table of contents

Safety information.....	5
Introduction.....	11
Before using the product for the first time.....	11
Maximizing lamp life.....	11
Physical installation.....	12
Fastening the fixture to a flat surface.....	12
Mounting the fixture on a truss.....	12
AC power.....	14
Linking fixtures to power in a chain.....	14
Fixture overview.....	16
Control data link.....	17
Tips for reliable data transmission.....	17
Connecting the data link.....	18
Fixture setup.....	19
Using the control menus.....	19
Setting DMX address.....	19
Lamp control settings.....	20
Fixture settings.....	21
Fixture information.....	23
Position calibration.....	24
Setting options by RDM.....	24
Scanning for RDM devices on the data link.....	24
Getting status and setting options by RDM.....	25
RDM functions.....	25
Effects.....	27
Dimming.....	27
Strobe effects.....	27
Pan and tilt.....	27
Colors.....	27
Gobos.....	28
Prism.....	28
Focus.....	28
Frost.....	28
Maintenance.....	29
Cleaning.....	29
Replacing gobos.....	30
Lamp replacement.....	32
Lamp temperature control.....	34
Replacing the primary fuse.....	34

Updating firmware.....	34
Service and repairs.....	34
DMX protocol	35
Control menus	39
Troubleshooting.....	41
Specifications.....	42

Safety information



WARNING!

Read the safety precautions in this manual before installing, operating or servicing this product.

The following symbols are used to identify important safety information on the product and in this manual:



Warning!

Safety hazard. Risk of severe injury or death.



Warning!

Powerful light emission. Risk of eye injury.



Warning!

See user manual for important safety information.



Warning!

Hazardous voltage. Risk of lethal or severe electric shock.



Warning!

Hot surfaces.



Warning!

Fire hazard.



Warning! Risk Group 3 (high risk) product according to EN 62471. Possibly hazardous radiation emitted from this product. May be harmful to the eyes. Do not stare at operating lamp and do not view the light output with optical instruments or any device that may concentrate the beam.

This lighting fixture is for professional use only and must be installed by a qualified technician. It is not for household use. It presents risks of severe injury or death due to fire hazards, electric shock and falls. It produces a powerful, concentrated beam of light that can create a fire hazard or a risk of eye injury if the safety precautions below are not followed.



Install, operate and service Martin® products only as directed in their user manuals, or you may create a safety hazard or cause damage that is not covered by product warranties.

Follow the safety precautions listed below and observe all warnings in this manual and printed on the product. Keep this user manual for future use.

For the latest user documentation and other information for this and all Martin® products, please visit the Martin website at <http://www.martin.com>

If you have any questions about how to install, operate or service the fixture safely, please contact your Martin® distributor (see www.martin.com/where-to for details) or call the Martin® 24-hour service hotline on +45 8740 0000, or in the USA on 1-888-tech-180.

Respect all locally applicable laws, codes and regulations when installing, operating or servicing the fixture.



Protection from electric shock

Do not expose the fixture to rain or moisture.

Disconnect the fixture from AC power before carrying out any installation or maintenance work and when the fixture is not in use.

Ensure that the fixture is electrically connected to ground (earth).

Use only a source of AC power that complies with local building and electrical codes and has both overload and ground-fault (earth-fault) protection.

Socket outlets or external power switches used to supply the fixture with power must be located near the fixture and easily accessible so that the fixture can easily be disconnected from power.

Replace defective fuses with ones of the specified type and rating only.

Isolate the fixture from power immediately if the power plug or any seal, cover, cable, or other component is damaged, defective, deformed, wet or showing signs of overheating. Do not reapply power until repairs have been completed

Before using the fixture, check that all power distribution equipment and cables are in perfect condition and rated for the electrical requirements of all connected devices.

The mains power input cable supplied with the fixture can safely supply only one fixture with mains power. Do not connect any device to the fixture's MAINS OUT socket when using this input cable. If you want to connect other fixtures to

the MAINS OUT socket, see 'Linking fixtures to power in a chain' on page 14.



Protection from burns and fire

Do not operate the fixture if the ambient temperature (T_a) exceeds 40° C (104° F).



The surface of the product casing can reach up to 100° C (212° F) during operation. Avoid contact by persons and materials. Allow the fixture to cool for at least 10 minutes before handling.

Keep flammable materials well away from the fixture. Keep all combustible materials (e.g. fabric, wood, paper) at least 200 mm (8 in.) away from the fixture head.

Ensure that there is free and unobstructed airflow around the fixture. Provide a minimum clearance of 0.5 m (20 in.) around fans and air vents.

Do not illuminate surfaces within 10 m (33 ft.) of the fixture.

Do not attempt to bypass thermostatic switches or fuses.

Do not stick filters, masks or other materials onto any optical component.

The fixture's lenses can focus the sun's rays inside the fixture, creating a risk of fire and damage. Do not expose the front of the fixture to sunlight or any other bright light source.



Protection from injury

Fasten the fixture securely to a fixed surface or structure when in use. The fixture is not portable when installed.

Ensure that any supporting structure and/or hardware used can hold at least 10 times the weight of all the devices they support.

If suspending from a rigging structure, fasten two (2) suitable rigging clamps to the fixture. Do not use safety cables as the primary means of support.

If the fixture is installed in a location where it may cause injury or damage if it falls, install as directed in this manual a secondary attachment such as a safety cable that will hold the fixture if a primary attachment fails. The secondary attachment must be approved by an official body such as TÜV as a safety attachment for the weight that it secures,

must comply with EN 60598-2-17 Section 17.6.6 and must be capable of bearing a static suspended load that is ten times the weight of the fixture and all installed accessories.

Allow enough clearance around the head to ensure that it cannot collide with an object or another fixture when it moves.

Check that all external covers and rigging hardware are securely fastened.

Block access below the work area and work from a stable platform whenever installing, servicing or moving the fixture.

Do not operate the fixture with missing or damaged covers, shields or any optical component.

Do not lift or carry the fixture by its head. Support the fixture by its base only.

In the event of an operating problem, stop using the fixture immediately and disconnect it from power. Do not attempt to use a fixture that is obviously damaged.

Do not modify the fixture in any way not described in this manual or install other than genuine Martin® parts.

Refer any service operation not described in this manual to a qualified technician.



Lamp safety

Install only a lamp that is approved by Martin® for use in the product.



Prolonged exposure to an unshielded discharge lamp can cause eye and skin burns. Do not look at an exposed lamp while it is lit. Do not operate the fixture with missing or damaged covers, shields, lenses, ultraviolet screens or any optical component.



A hot discharge lamp is under pressure and can explode without warning. Allow the fixture to cool for at least 2 hours and protect yourself with safety glasses and gloves before handling a lamp.

Replace the lamp immediately if it becomes visually deformed, damaged or in any way defective.

Monitor hours of lamp use. Replace the lamp before or when it reaches its average lifetime as specified in this manual or by the lamp manufacturer or if you notice a fall in light output.

If you exceed the average lamp lifetime, the lamp may explode and damage the fixture.

If the quartz envelope of a discharge lamp is broken, the lamp releases a small quantity of mercury and other toxic gases. If a discharge lamp explodes in a confined area, evacuate the area and ventilate it thoroughly for 30 minutes. Wear nitrile gloves when handling a broken discharge lamp. Do not use a vacuum cleaner to remove pieces of a broken lamp. Treat broken or used discharge lamps as hazardous waste: put them in a plastic bag and send to a specialist for disposal.



Protection from eye injury

Warning! Risk Group 3 (high risk) product according to EN 62471.

Do not look directly into the product's light output.

Do not look at operating lamp. Eye injury may result.

Do not expose persons to the product's light output from a distance of less than 30 m (98 ft.).

The fixture falls into the following Risk Groups according to EN62471 for blue light at the distances indicated below:

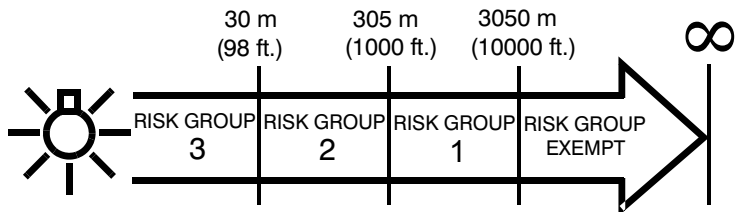

Avoid eye or skin exposure to unshielded product. UV emitted from this product. Possibly hazardous optical radiation emitted from this product.

Do not look at the light output with magnifiers, telescopes, binoculars or similar optical instruments that may concentrate the light output.

Ensure that persons are not looking directly into the front of the fixture when the product lights up suddenly. This can happen when power is applied, when the product receives a DMX signal, or when certain control menu items are selected.

To minimize the risk of eye irritation or injury, disconnect the fixture from power at all times when the fixture is not in use and provide well-lit conditions to reduce the pupil diameter of anyone working on or near the fixture.

Introduction

The RUSH® MH 11 Beam is a powerful profile fixture with a Philips MSD Platinum 11R 250W short-arc discharge lamp that produces a high intensity beam. The fixture provides 540° of pan movement, 260° of tilt movement, motorized focus lens, smooth full-range dimming, strobing shutter and pulse effects, 8 user-replaceable rotating gobos, 13 color filters, a rotating prism, and a frost filter. The short-arc source and rugged, lightweight construction make it ideal for live shows, TV events, stage, concerts, and nightclubs.

The RUSH® MH 11 Beam can be controlled using any DMX-compliant controller and may be remotely configured by RDM. It is supplied with this user manual, a 1.5 m (4.9 ft.) power cable ready for a local power plug (not included), and two mounting brackets for attachment of suitable, user-supplied rigging clamps.

Before using the product for the first time

1. Read 'Safety information' on page 5 before installing, operating or servicing the fixture.
2. Unpack and ensure that there is no transportation damage before using the fixture. Do not attempt to operate a damaged fixture.
3. If the fixture is not going to be hard-wired to a mains supply, install a local power plug (not supplied) on the end of the supplied power cable.
4. Ensure that the voltage and frequency of the power supply match the power requirements of the fixture.
5. Check the support pages on the Martin Professional website at www.martin.com for the most recent user documentation and technical information about the fixture. Martin® user manual revisions are identified by the revision letter at the bottom of the inside cover.

Note that whenever AC power is applied to the fixture, it will reset all effects and functions to their home positions. Be prepared for the fixture head to move. A reset usually takes around 20 seconds.

Maximizing lamp life

To obtain maximum output over the lifetime of the fixture's lamp:

- Each time you power the lamp on, allow it to warm up for at least 5 minutes before you power it off.
- Before shutting down power completely, power the lamp off but leave power applied to the fixture for a few minutes so that cooling fans can prevent any momentary lamp temperature increase caused by heat from surrounding components.

Physical installation



Warning! Read ‘Safety information’ on page 5 before installing the fixture.

The fixture is designed for indoor use only and must be used in a dry location with adequate ventilation. Ensure that none of the fixture’s ventilation slots are blocked.

Fasten the fixture to a secure structure or surface. Do not stand it on a surface or leave it where it can be moved or fall over. If you install the fixture in a location where it may cause injury or damage if it falls, secure it as directed in this user manual using a securely anchored safety cable that will hold the fixture if the primary fastening method fails.

Do not use the fixture to illuminate surfaces within 10 m (33 ft.) of the fixture.

Martin® can supply safety cables and rigging clamps that are suitable for use with the fixture (see ‘Accessories’ on page 44).

Fastening the fixture to a flat surface

The fixture can be fastened to a hard, fixed, flat surface. Ensure that the surface and all fasteners used can support at least 10 times the weight of all fixtures and equipment they will support.

Fasten the fixture securely. Do not stand it on a surface or leave it where it can be moved or fall over. If you install the fixture in a location where it may cause injury or damage if it falls, secure it as directed below with a securely anchored safety cable that will hold the fixture if the primary fastening method fails.

Mounting the fixture on a truss

The fixture can be clamped to a truss or similar rigging structure in any orientation. When installing the fixture hanging vertically down, you can use an open-type clamp such as a G-clamp. When installing in any other orientation, you must use a closed-type rigging clamp such as half-coupler clamp (see illustration on right) that completely encircles the truss chord.



To clamp the fixture to a truss:

1. Check that the rigging structure can support at least 10 times the weight of all fixtures and equipment to be installed on it.

2. Block access under the work area.
3. The fixture is supplied with two omega-type brackets to which rigging clamps can be attached. Check that the rigging clamps are undamaged and approved for the fixture's weight. Bolt a rigging clamp securely to each bracket. The bolts used must be M12, grade 8.8 steel minimum, and fastened with self-locking nuts.
4. Fasten the omega brackets to the base of the fixture using the brackets' quarter-turn fasteners. Turn quarter-turn fasteners a full 90° to lock them (see illustration on right).
5. Working from a stable platform, hang the fixture on the truss and fasten the rigging clamps onto the truss.
6. Secure the fixture with a safety cable as directed below.
7. Check that the head will not collide with other fixtures or objects.

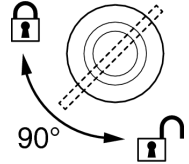

Securing with a safety cable

Secure the fixture with a safety cable (or other secondary attachment) that is approved for the weight of the fixture so that the safety cable will hold the fixture if a primary attachment fails.

Loop the safety cable through the eye bracket in the fixture's baseplate between the clamps (arrowed in illustration below) and around a secure anchoring point.

If a safety cable attachment point becomes damaged or deformed, do not use the fixture. Return it to a Martin Service Centre for repair.

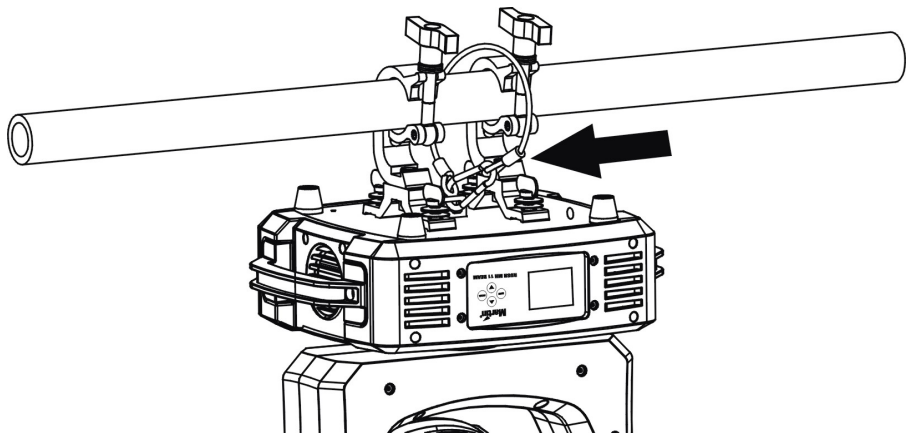

AC power



Read ‘Safety information’ on page 5 before connecting the fixture to AC mains power.



Warning! The mains power input cable supplied with the fixture is rated 9 A and can safely supply only one fixture with mains power. Do not connect any device to the fixture’s MAINS OUT socket when using this input cable. If you want to connect other fixtures to the MAINS OUT socket, see ‘Linking fixtures to power in a chain’ below.

For protection from electric shock, the fixture must be grounded (earthed). The power distribution circuit must be equipped with a fuse or circuit breaker and ground-fault (earth-fault) protection.

Socket outlets or external power switches used to supply the fixture with power must be located near the fixture and easily accessible so that the fixtures can easily be disconnected from power.

Do not use an external dimming system to supply power to the fixture, as this may cause damage to the fixture that is not covered by the product warranty.

The fixture can be hard-wired to a building electrical installation if you want to install it permanently, or a power plug (not supplied) that is suitable for the local power outlets can be installed on the power cable.

If you install a power plug on the power cable, install a grounding type (earthed) plug with integral cable grip that is rated minimum 8 A at a suitable voltage for your local power system. Follow the plug manufacturer’s instructions and connect the wires in the power cable as shown in this table:

	Live or L	Neutral or N	Earth, Ground or 
US system	Black	White	Green
EU system	Brown	Blue	Yellow/green

The fixture has an auto-ranging power supply that accepts AC mains power at 100-240 V at 50/60 Hz. Do not apply AC mains power at any other voltage or frequency to the fixture.

Linking fixtures to power in a chain

The mains power input cable supplied with the fixture is rated 9 A and can safely supply power to one fixture only. If you want to use the MAINS OUT socket on the fixture to link power to the next fixture in a daisy-chain, you

must obtain a 16 A-rated power input cable and 16-A rated power relay cables available as accessories from Martin® (see 'Accessories' on page 44). Using these 16 A-rated cables, you can link:

- Maximum two (2) RUSH® MH 11 Beam fixtures in total at 100-120 V,
or
- Maximum four (4) RUSH® MH 11 Beam fixtures in total at 200-240 V.

If you install a power plug (cord cap) on the 16 A-rated power input cable, install a grounding type (earthed) plug with integral cable grip that is rated minimum 16 A at the correct voltage rating for your local power supply.

Fixture overview

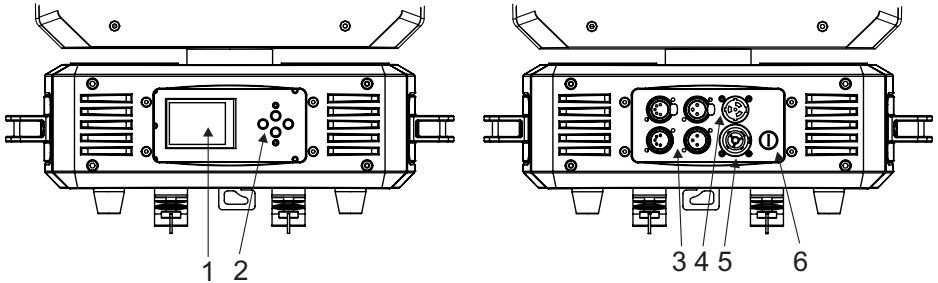

1 – Display

The display is used to configure the fixture and show status.

2 – Control buttons

- MENU: Press to activate the menu. Within the menu, press to escape and return to the previous level. Press and hold to exit the menu.
- DOWN: Press to scroll down through menu options.
- UP: Press to scroll up through menu options.
- ENTER: Press to confirm and save the menu selection. Press and hold to exit the menu.

3 –XLR DMX input/output sockets

For your convenience, 3 and 5-pin XLR sockets are provided for DMX input and output (through to next fixture). Do not connect output cables to both the 3-pin and 5-pin output sockets at the same time as this may cause data errors (in other words, you cannot use the two outputs on the fixture to split the DMX line).

4 – AC mains power input

A yellow Neutrik True1 PowerCon inlet connector is provided to connect the fixture to mains power.

5 – AC mains power link output

A yellow Neutrik True1 PowerCon outlet connector is provided to allow mains power to be linked to the next fixture. Refer to the section above “Linking fixtures to power in a chain” for safe use of this connector.

6 – Mains fuse

The fixture’s 5T 250 V, 8 A fuse is located in a fuse holder next to the power input/output connectors.

Control data link

A DMX 512 data link is required in order to control the fixture via DMX. The fixture has 3-pin and 5-pin XLR connectors for DMX data input and output.

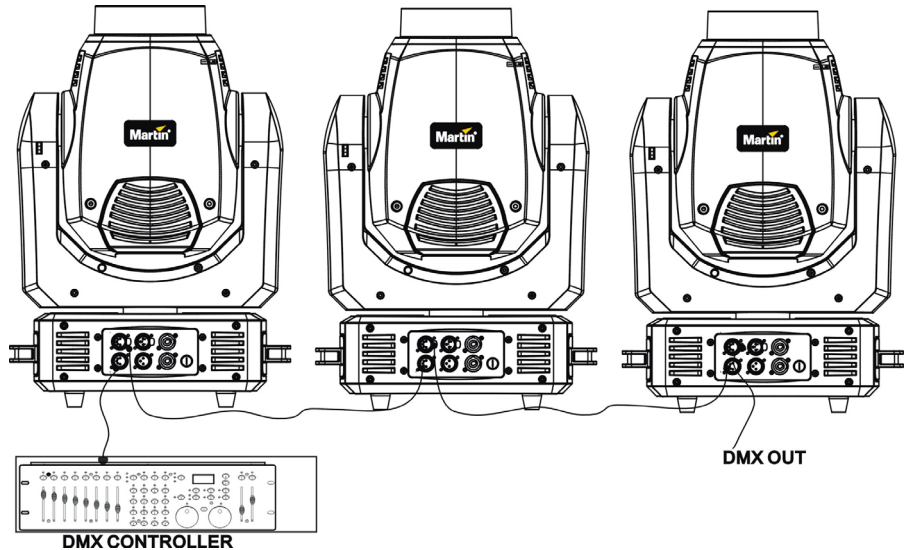

Up to 32 devices can be linked together on a single daisy chain. The total number of fixtures in one 512-channel DMX universe is limited by the number of DMX channels required by the fixtures. Note that if independent control of a fixture is required, it must have its own DMX channels. Fixtures that are required to behave identically can share the same DMX address and channels. To add more fixtures or groups of fixtures when the above limits are reached, add a DMX universe and/or split the daisy-chained link into branches using a powered DMX splitter.

Tips for reliable data transmission

Use shielded twisted-pair cable designed for RS-485 devices: standard microphone cable cannot transmit control data reliably over long runs. 24 AWG cable is suitable for runs up to 300 meters (1000 ft.). Heavier gauge cable and/or an amplifier is recommended for longer runs.

- pin 1 = shield
- pin 2 = cold (-)
- pin 3 = hot (+).

Pins 4 and 5 in the 5-pin XLR connectors are not used in the fixture but are available for possible additional data signals as required by the DMX512-A standard. Standard pin-out is pin 4 = data 2 cold (-) and pin 5 = data 2 hot (+).

To split the link into branches, use an opto-isolated splitter such as the Martin® DMX 5.3 Splitter. Terminate the link by installing a termination plug in the output socket of the last fixture. The termination plug, which is a male XLR plug with a 120 Ohm, 0.25 watt resistor soldered between pins 2 and 3, “soaks up” the control signal so it does not reflect and cause interference. If a splitter is used, terminate each branch of the link.

Connecting the data link

To connect the fixture to data:

1. Connect the DMX data output from the controller to the closest fixture’s male XLR DMX input connector.
2. Connect the first fixture’s DMX output to the DMX input of the next fixture and continue connecting fixtures output to input.
3. Terminate the last fixture on the link with a DMX termination plug.

Fixture setup

This section explains the fixture characteristics you can set that determine how it can be controlled and will behave. You choose the settings using the menus available from the control panel, and they are retained even when the fixture is powered off.

Options can also be set over the DMX line using RDM from a suitable controller, see “Setting options by RDM” on page 24.

A complete map of the control menu structure and brief explanations of their purposes can be found on page 39. Only the most-used functions are described in this section.

Using the control menus

To access the control menus, press the MENU button.

Navigate the menu structure using the ENTER, DOWN and UP buttons.

To select a menu option or to confirm a selection, press the ENTER button.

To return to a higher level in the menu structure without making a change, press the MENU button.

To exit the control menus completely, press and hold the MENU button.

Setting DMX address

Each fixture must be assigned a DMX address. The DMX address, also known as the start channel, is the first channel used to receive instructions from a DMX controller. The fixture is controlled using 18 DMX channels. If a fixture has a DMX address of 1, then it uses channels 1 to 18 inclusive. The following fixture in the DMX chain can then be set to a DMX address of 19.

For independent control, each fixture must be assigned its own control channels. Two fixtures of the same type may share the same address if identical behavior is desired. Address sharing can be useful for diagnostic purposes and symmetric control, particularly when combined with the inverse pan and tilt options.

To set the fixture’s DMX address:

1. Enter the control menu and select DMX FUNCTION. Press ENTER.
2. Select DMX ADDRESS and press ENTER.
3. Use the UP and DOWN buttons to select the desired address setting.
4. Press ENTER to confirm your selection.

Lamp control settings

The fixture's lamp may be controlled automatically or manually using these settings. If the lamp is hot from having been previously lit, it will not restrike until the temperature falls below the MAX ON AT TEMPERATURE, which is fixed at 45° C (113° F). If the temperature rises above the LAMP OFF TEMPERATURE, which is 130° C (266° F), then the lamp will shut down.

Switching lamp on or off manually

The lamp can be turned on or off from the control panel:

1. In the LAMP SETTING menu select ON/OFF option and press ENTER.
2. Select ON or OFF and press ENTER.
3. Press ENTER to confirm or press MENU to exit.

Switching on lamp automatically at power-on

Normally the lamp will strike automatically when power is applied to the fixture. You can disable this feature if you want to:

1. In the LAMP SETTING menu select STATE AT POWER option and press ENTER.
2. Select ON to enable automatic lamp strike at power up (default), or OFF to disable it.
3. Press ENTER to confirm or press MENU to exit.

Switching on lamp automatically when DMX is received

The fixture will normally strike its lamp if it receives a DMX signal and the lamp is off. You can disable this feature:

1. In the LAMP SETTING menu select ON VIA DMX ON and press ENTER.
2. Select ON to enable automatic lamp on when DMX is received (default) or OFF to disable it.
3. Press ENTER to confirm or press MENU to exit.

Lamp control via DMX

You can remotely turn the lamp off and on using a DMX controller. This feature can be disabled if you want:

1. In the LAMP SETTING menu select OFF VIA DMX and press ENTER.
2. Select ON to enable remote lamp control (default) or OFF to disable it.
3. Press ENTER to confirm or press MENU to exit.

Fixture settings

Hold or blackout on loss of DMX

If the fixture loses the DMX signal, it can either hold the look it's currently displaying or black out. The default is HOLD. To change the setting:

To set fixture behavior when it is not receiving DMX:

1. In the FIXTURE SET menu select LOSS OF DMX and press ENTER.
2. Select BLACK OUT or HOLD (default).
3. Press ENTER to confirm or press MENU to exit.

Inverting pan and tilt

You can reverse DMX pan or tilt control to provide mirror image movements or to correct for a fixture being rigged the wrong way round. The default setting is OFF. To reverse pan or tilt control:

1. In the FIXTURE SET menu select STATUS SETTINGS and press ENTER.
2. Select PAN INVERSE or TILT INVERSE and press ENTER.
3. Select ON to reverse control, or OFF for normal control (default).
4. Press ENTER to confirm or press MENU to exit.

Pan/tilt correction when knocked

Normally if the fixture is knocked or pushed while set to a position it will automatically return to the correct position. You can turn this feature off:

1. In the FIXTURE SET menu select STATUS SETTINGS and press ENTER.
2. Select P/T FEEDBACK and press ENTER.
3. Select OFF to disable automatic position correction or ON to enable the function (default).
4. Press ENTER to confirm or press MENU to exit.

Low power mode on loss of DMX (hibernation)

If DMX is lost, after 15 minutes the fixture turns off the lamp and goes into low power mode. The fixture automatically resets and returns to full power when DMX is restored. You can disable this feature or change the delay:

1. In the FIXTURE SET menu select STATUS SETTINGS and press ENTER.
2. Select HIBERNATION and press ENTER.
3. Select OFF (default) to disable hibernation. To enable hibernation, select a delay time of 1 to 99 minutes.
4. Press ENTER to confirm or press MENU to exit.

Blackout during pan/tilt movements

The fixture can be set to black out during pan or tilt movement. To enable this option:

1. In the FIXTURE SET menu select BI.O.P/T MOVE and press ENTER.
2. Select ON to enable automatic blackout, or OFF to disable it (default).
3. Press ENTER to confirm or press MENU to exit.

Blackout during color/gobo change

The fixture can be set to black out during pan or tilt movement. To enable this option:

1. In the FIXTURE SET menu select BI.O.OTHER MOVE and press ENTER.
2. Select ON to enable automatic blackout, or OFF to disable it (default).
3. Press ENTER to confirm or press MENU to exit.

Display backlight auto-dim

The LCD control display automatically dims 5 minutes after the last key press, but you can change the delay time:

1. In the FIXTURE SET menu select DISPLAY SETTING and press ENTER.
2. Select BACKLIGHT AUTO and press ENTER.
3. Select a delay from 2 to 60 minutes (default 5 minutes).
4. Press ENTER to confirm or press MENU to exit.

Clear error messages from display

If the fixture detects a fault it will display an error message on the display. You can clear these messages but you must first enter a password which is "050". To enter the password and clear the messages:

1. In the FIXTURE SET menu, select SERVICE SETTING and press ENTER.
2. Select PASSWORD and press ENTER.
3. Use the UP and DOWN buttons to select PASSWORD=050 and press ENTER.
4. Select CLEAR ERR. INFO and press ENTER.
5. Select YES to clear the error codes, or NO to keep them.
6. Press ENTER to confirm or press MENU to exit.

Restore to factory settings

To restore all settings to factory defaults:

1. In the FIXTURE SET menu select FACTORY SETTINGS and press ENTER

2. Select YES to restore factory settings.
3. Press ENTER to confirm or MENU to exit without restoring.

Fixture information

Total operating hours

To display the fixture's total operating hours:

1. In the INFORMATION menu, select TIME INFORMATION and press ENTER.
2. Select TOTAL USE TIME and press ENTER.
3. The total operating time of the fixture is displayed in hours.
4. Press MENU to exit.

Viewing and resetting Lamp on hours

To display the number of hours the lamp has run:

1. In the INFORMATION menu, select TIME INFORMATION and press ENTER.
2. Select LAMP ON HOURS and press ENTER.
3. The total on time of the lamp is displayed in hours.

To reset lamp hours after installing a new lamp:

1. In the INFORMATION menu, select TIME INFORMATION and press ENTER.
2. Select RESET LAMP TIME and press ENTER.
3. At the PASSWORD prompt, scroll to "038" using the UP/DOWN buttons and press ENTER.
4. Select YES (or NO to abandon reset).
5. Press ENTER to confirm or press MENU to exit.

Head Temperature

To display the temperature inside the head:

1. In the INFORMATION menu, select HEAD TEMPERATURE and press ENTER.
2. The temperature is displayed. You can select Celsius or Fahrenheit in the FIXTURE SET / DISPLAY SETTING / TEMPERATURE UNIT option.
3. Press MENU to exit.

Displaying software version

To display the version of firmware installed on each circuit board:

1. In the INFORMATION menu, select SOFTWARE VERSION and press ENTER.
2. The firmware for each board is displayed.
3. Press MENU to exit.

Position calibration

If an effect does not reset to its home position, you can recalibrate it using a position offset. To enter an offset:

1. Enter the control menu and select OFFSETTING. Press ENTER.
2. At the CALIBRATION PASSWORD prompt, scroll to 050 using the UP/DOWN buttons and press ENTER.
3. Select an effect to adjust and press ENTER.
4. Use the UP/DOWN buttons to increase or decrease the offset value. When the effect reaches the correct position, press ENTER.
5. Press MENU to exit.

Setting options by RDM

You can remotely configure the fixture over the DMX line using RDM. Martin® offers a range of suitable RDM-compatible controllers.

Martin® M-PC is a Windows-based application available from Martin® that lets you set up, manage and control a lighting installation from a PC that is connected to the installation via a DMX data link. To use Martin® M-PC, connect a PC running the application to the data link via a USB-to-DMX interface box such as the Martin® M-DMX.

A full list of the RDM functions that the MH 11 fixture supports is given at the end of this chapter. These functions are generally referred to using the more specific term 'PIDs' or 'Parameter IDs'.

Scanning for RDM devices on the data link

Before you can communicate with fixtures using RDM, you must send a scan command (also called a device discovery command) to all the devices on the data link so that the RDM controller can identify them. It does this by retrieving each device's factory-set unique identifier (UID). This process can take some time depending on the number of devices on the link.

To identify the fixtures on the link:

1. Check that the fixtures are correctly connected to the RDM controller on the data link and that power is applied to all fixtures.
2. In Martin® M-PC, go to RDM CONTROLLER → DISCOVER DEVICES.

3. Give the controller time to identify the devices on the link and prepare for communication with the devices.

Getting status and setting options by RDM

The status and options listed in the table below can be read and set by RDM.

You can set an option on one fixture by sending a unicast RDM command to that one fixture only, or you can set the same option on all the fixtures on the data link by sending a broadcast RDM command to all the devices on the link.

For status reading, you can only use unicast RDM to read information from an individual fixture.

RDM functions

As a minimum, MH 11 supports the following RDM functions:

Device discovery

DISC_UNIQUE_BRANCH
DISC_MUTE
DISC_UN_MUTE

Device management

	GET	SET
DEVICE_INFO	✓	
IDENTIFY_DEVICE	✓	✓
DMX_START_ADDRESS	✓	✓
SOFTWARE_VERSION_LABEL	✓	
SUPPORTED_PARAMETERS	✓	
PARAMETER_DESCRIPTION	✓	
COMMS_STATUS	✓	
QUEUED_MESSAGE	✓	
STATUS_MESSAGES	✓	

STATUS_ID_DESCRIPTION	✓	
CLEAR_STATUS_ID		✓
DEVICE_MODEL_DESCRIPTION	✓	
MANUFACTURER_LABEL	✓	
DEVICE_LABEL	✓	✓
FACTORY_DEFAULTS		✓
DMX_PERSONALITY	✓	✓
DMX_PERSONALITY_DESCRIPTION	✓	
SENSOR_DEFINITION	✓	
SENSOR_VALUE	✓	
DEVICE_HOURS	✓	
LAMP_HOURS	✓	✓
BOOT_SOFTWARE_VERSION_ID	✓	
BOOT_SOFTWARE_VERSION_LABEL	✓	
LAST_STATE		✓
DIMMER_CURVE		✓
LAMP_STRIKE	✓	✓
LAMP_STATE	✓	
DEVICE_POWER_CYCLES	✓	
DISPLAY_INVERT	✓	✓
SLOT_DESCRIPTION	✓	✓
PAN_INVERT	✓	✓
TILT_INVERT	✓	✓
RESET_DEVICE		✓

Effects

This section describes the effects provided by the RUSH® MH 11 Beam. See 'DMX protocol' on page 35 for a full list of the DMX channels and values required to control the different effects.

Dimming

Overall intensity can be precisely adjusted from 0 to 100% using 16-bit coarse and fine control.

Strobe effects

A mechanical shutter provides instant open and blackout, random and variable speed flash from 1 to 12 flashes per second, and pulse effects.

Pan and tilt

The fixture's head can be panned through 540° and tilted through 260° with 16-bit coarse and fine control. Using the control menus it is possible to invert pan or tilt movement. A position feedback circuit provides automatic position correction if the fixture is knocked out of position.

Light output can be set to black out when the head moves using either the Auto-blackout = ON command on DMX channel 18, or the B.I.O.P/T Move personality setting in the control menu.

Colors

The color wheel provides the 13 colors listed below plus an open position. Colors can be selected in full position steps or continuously scrolled to give split colors. The wheel can be rotated at varying speeds, both clockwise and counter-clockwise, or display random colors at slow, medium and fast speeds.

Slot 1: red	Slot 6: cyan	Slot 11: CTO
Slot 2: blue	Slot 7: pink	Slot 12: CTB
Slot 3: green	Slot 8: orange	Slot 13: UV
Slot 4: Rose	Slot 9: aqua	
Slot 5: yellow	Slot 10: purple	

Gobos

The fixture contains one gobo wheel with gobo positions as shown below:

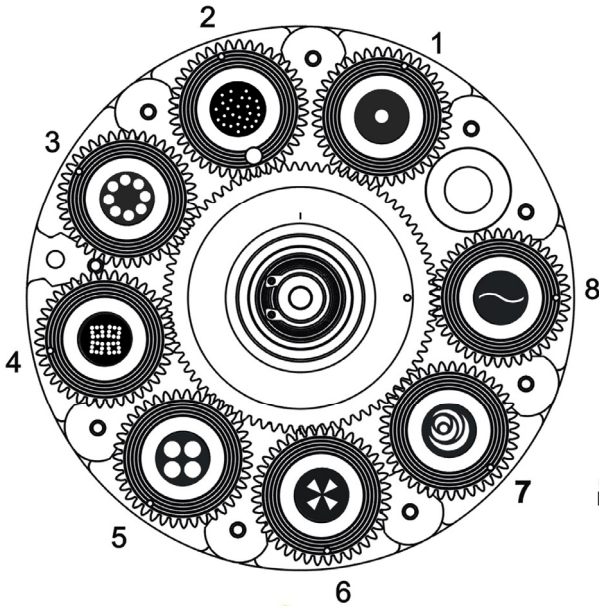

Gobo wheel (rotating gobos)

Individual gobos can be set to indexed positions, and rotated clockwise and counter-clockwise. Gobo shake is also available.

When option “BI.O. Other Move” is ON, the fixture blacks out during color and gobo changes.

Focus

A motorized focus lens provides 16-bit coarse and fine adjustment of gobo image sharpness.

Prism

The fixture incorporates an eight-facet circular prism which can be inserted into the beam for split effects. The prism can be set to an indexed position or rotated clockwise or counter-clockwise.

Frost

A frost filter can be inserted into the beam for a soft, diffuse wash effect. Note: you cannot use both Frost and Prism at the same time.

Maintenance



Warning! Read ‘Safety information’ on page 5 before servicing the fixture.

Disconnect the fixture from mains power before cleaning or servicing.

Service fixtures in an area where there is no risk of injury from failing parts, tools or other materials.

The user may carry out the service operations described in this manual. All other service operations must be carried out by an authorized Martin® service technician. Do not try to repair the fixture yourself, as you may create a safety risk or cause damage that is not covered by the product warranty.

Installation, on-site service and maintenance can be provided worldwide by the Martin Professional™ Global Service organization and its approved agents, giving owners access to Martin’s expertise and product knowledge in a partnership that will ensure the highest level of performance throughout the product’s lifetime. Please contact Martin® for details.

Cleaning

Excessive dust, smoke fluid, and particle buildup degrades performance, causes overheating and will damage the fixture. Damage caused by inadequate cleaning or maintenance is not covered by the product warranty.

The cleaning of external optical lenses must be carried out periodically to optimize light output. Cleaning schedules for lighting fixtures vary greatly depending on the operating environment. It is therefore impossible to specify precise cleaning intervals for the fixture. Environmental factors that may result in a need for frequent cleaning include:

- Use of smoke or fog machines.
- High airflow rates (near air conditioning vents, for example).
- Presence of cigarette smoke.
- Airborne dust (from stage effects, building structures and fittings or the natural environment at outdoor events, for example).

If one or more of these factors is present, inspect fixtures within their first 100 hours of operation to see whether cleaning is necessary. Check again at frequent intervals. This procedure will allow you to assess cleaning requirements in your particular situation. If in doubt, consult your Martin dealer about a suitable maintenance schedule.

Use gentle pressure only when cleaning, and work in a clean, well-lit area. Do not use any product that contains solvents or abrasives, as these can cause surface damage.

To clean the fixture:

1. Disconnect the fixture from power and allow it to cool for at least 10 minutes.
2. Vacuum or gently blow away dust and loose particles from the outside of the fixture and the air vents at the back and sides of the head and in the base with low-pressure compressed air.
3. Clean surfaces by wiping gently with a soft, clean lint-free cloth moistened with a weak detergent solution. Do not rub glass surfaces hard: lift particles off with a soft repeated press. Dry with a soft, clean, lint-free cloth or low-pressure compressed air. Remove stuck particles with an unscented tissue or cotton swab moistened with glass cleaner or distilled water.
4. Check that the fixture is dry before reapplying power.

Replacing gobos

The rotating gobos can be replaced with custom gobos that match the quality and specifications of the gobos supplied with the fixture (see 'Interchangeable Gobos' on page 43).

Optical components have fragile coatings and are exposed to very high temperatures. Handle and store components with care. Wear cotton gloves while handling them. Keep them perfectly clean and free of oil and grease to reduce the risk of heat damage.

To replace a rotating gobo:

1. Disconnect the fixture from power and allow it to cool for at least 10 minutes.
2. See illustration to right. Loosen the screws indicated with a TX20 TORX screwdriver and remove the head shell.



3. The rotating gobos sit in goboholders that slot into clips in the rotating gobo wheel. Find the gobo you want to replace. See below. Pull its goboholder away from the gobo wheel slightly, then lift the goboholder out of its clip in the wheel.

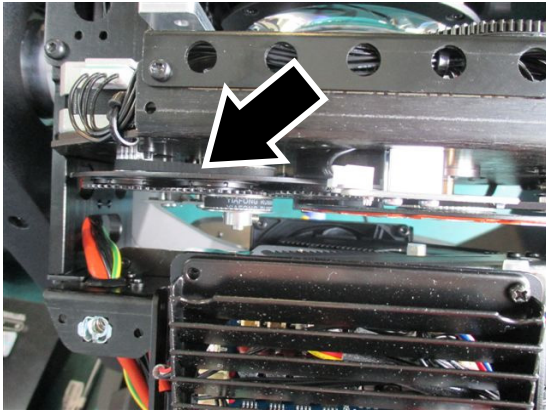

4. The gobo is held by a retaining spring. Use a flat-bladed screwdriver or tweezers to lever the end of the spring out of its slot, then lift out the spring.



5. Remove spring, retaining ring and gobo.



6. Insert the new gobo in the holder. Insert the retaining ring, making sure the tab fits in the goboholder slot.
7. Replace the retaining spring with the narrow end in, against the ring. Make sure the outside end of the spring is held firmly in place in its slot in the goboholder.
8. Slide the tab on the goboholder under the clip on the gobowheel and make sure that the teeth on the goboholder engage the gobo wheel correctly.
9. Replace the head cover and be ready for the head to move when you reapply power.

Lamp replacement



Warning! Wear safety glasses and gloves when handling lamps.

Allow the fixture to cool for at least 2 hours before handling a lamp.

To avoid the risk of a discharge lamp exploding in the fixture, replace the lamp when it reaches its specified lifetime (see Lamp on page 42).

Install only lamps that are approved by Martin® for this fixture (see Lamp on page 42).

If a lamp breaks, ventilate the room for 30 minutes, put on nitrile gloves and remove the pieces. Put the pieces in a sealed plastic bag and take them to your local waste facilities for specialist recycling. Do not use a vacuum cleaner to clean up pieces of a broken lamp.

The lamp must be perfectly clean and totally free of oil and grease. Never touch the lamp with bare hands. If you contaminate the lamp, clean it with an alcohol wipe and then dry it with a lint-free cloth.

To replace the lamp:

1. Disconnect the fixture from power and allow it to cool for one hour.
2. Remove the lamp cover using a TX10 TORX screwdriver.

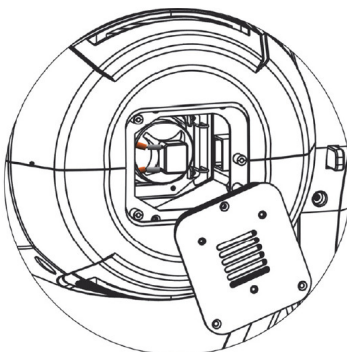
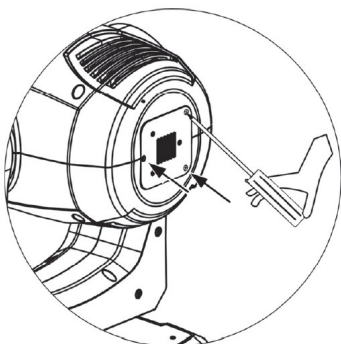

3. Squeeze and unhook the ends of the lamp retaining spring. Pivot the spring away from the lamp.

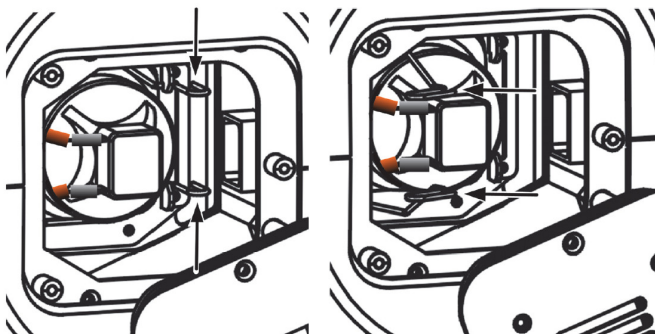

4. Carefully pull the lamp wires off the connection pins. Remove the lamp.

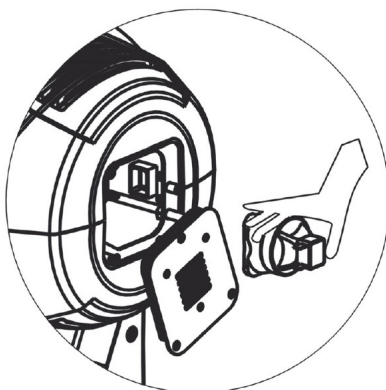

5. Avoid direct contact with the new lamp. Either wear clean lint-free cotton gloves or hold the lamp with the included cloth. Remove the new lamp from its packaging and attach the wires to the connection pins.

6. With the connection pins pointing to the left, away from the retaining spring, seat the new lamp in the fixture. Secure the lamp with the retaining spring.
7. Reinstall the lamp cover before applying power.
8. Reset the lamp hours counter as described on page 23.

Lamp temperature control

The lamp temperature is monitored to check for high temperatures caused by fan failure or blockage. If the lamp sensor reaches the LAMP OFF TEMPERATURE, which is fixed at 130° C (266° F), for more than 5 minutes then the lamp shuts down automatically. The lamp will restrike automatically when the temperature cools to the MAX ON AT TEMPERATURE, which is fixed at 45° C (113° F).

Replacing the primary fuse

If the fixture is completely dead, the fixture's primary fuse may have blown and it may be necessary to install a new fuse. Replace with a fuse of the same size and specified rating only.

If you need to replace the fuse:

1. Disconnect the fixture from power and allow it to cool.
2. Unscrew the cap of the fuse holder (shown on page 16) and remove the fuse.
3. Replace with a fuse of the same size and rating only.
4. Screw the fuse holder cap back on before reapplying power.

Updating firmware

If Martin releases an updated version of firmware for this fixture, you can update it using the Martin Companion Software using M-DMX. See www.martin.com.

Service and repairs

Never try to repair the fixture by yourself as this may result in damage or malfunction and it may potentially void your product warranty. The equipment must only be serviced or repaired by an authorized Martin service technician.

DMX protocol

Channel	Value	Function	Fade type	Default value
1		Dimmer, coarse	Fade	0
	0-255	Intensity 0 → 100%		
2		Dimmer, fine	Fade	0
	0-255	Dimmer intensity fine		
3		Shutter	Snap	50
	0-31	Shutter closed		
	32-63	Shutter open		
	64-95	Strobe effect slow → fast		
	96-127	Pulse, fast close & slow open		
	128-159	Pulse, fast open & slow close		
	160-191	Sequential pulse effects		
	192-223	Random strobe effect slow → fast		
224-255	Shutter open			
4		Color Wheel	Snap	0
		<i>Continuous Scroll</i>		
	0	Open		
	1-11	Open → Red		
	12	Red (Color 1)		
	13-22	Red → Blue		
	23	Blue (Color 2)		
	24-32	Blue → Green		
	33	Green (Color 3)		
	34-42	Green → Magenta		
	43	Magenta (Color 4)		
	44-52	Magenta → Yellow		
	53	Yellow (Color 5)		
	54-62	Yellow → Light blue		
	63	Light blue (Color 6)		
	64-73	Light blue → Pink		
	74	Pink (Color 7)		
	75-84	Pink → Orange		
	85	Orange (Color 8)		
	86-95	Orange → Aqua		
	96	Aqua (Color 9)		
	97-105	Aqua → Purple		
	106	Purple (Color 10)		
	107-114	Purple → CTO		
	115	CTO (Color 11)		
	116-124	CTO → CTB		
	125	CTB (Color 12)		
126-136	CTB → UV			
137	UV (Color 13)			
138-146	UV → Open			

Channel	Value	Function	Fade type	Default value
	147	Open		
		<i>Stepped Scroll</i>		
	148-151	Red		
	152-155	Blue		
	156-159	Green		
	160-163	Magenta		
	164-167	Yellow		
	168-171	Light blue		
	172-175	Pink		
	176-179	Orange		
	180-183	Aqua		
	184-187	Purple		
	188-191	CTO		
	192-195	CTB		
	196-199	UV		
		<i>Continuous rotation</i>		
	200-220	Clockwise, fast → slow		
	221-222	No rotation		
	223-243	Counterclockwise, slow → fast		
		<i>Random colors</i>		
244 - 247	Fast			
248 - 251	Medium			
252 - 255	Slow			
5		Rotating Gobos: Function and Selection	Snap	0
		<i>Gobo indexing, set position on ch. 6</i>		
	0-23	Open		
	24-29	Gobo 1, indexed		
	30-35	Gobo 2, indexed		
	36-41	Gobo 3, indexed		
	42-47	Gobo 4, indexed		
	48-53	Gobo 5, indexed		
	54-59	Gobo 6, indexed		
	60-65	Gobo 7, indexed		
	66-71	Gobo 8, indexed		
		<i>Gobo rotation, set speed and direction on ch. 6</i>		
	72-76	Gobo 1, rotating		
	77-81	Gobo 2, rotating		
	82-86	Gobo 3, rotating		
	87-91	Gobo 4, rotating		
	92-96	Gobo 5, rotating		
97-101	Gobo 6, rotating			

Channel	Value	Function	Fade type	Default value
	102-106	Gobo 7, rotating		
	107-111	Gobo 8, rotating		
		<i>Rotating gobo shake</i>		
	112-121	Gobo 1, shake		
	122-131	Gobo 2, shake		
	132-141	Gobo 3, shake		
	142-151	Gobo 4, shake		
	152-161	Gobo 5, shake		
	162-171	Gobo 6, shake		
	172-181	Gobo 7, shake		
	182-191	Gobo 8, shake		
		<i>Gobo wheel 1 rotation</i>		
	192-223	Clockwise rotation, fast → slow		
	224-255	Counterclockwise rotation, slow → fast		
6		Rotating Gobos: Indexing and Speed	Fade	128
		<i>If indexed gobo selected on ch. 5</i>		
	0-255	Gobo angle, coarse, 0°-360°		
		<i>If rotating gobo selected on ch. 5</i>		
	0-31	No rotation (0°)		
	32-93	Clockwise gobo rotation, fast → slow		
	94-127	No rotation		
	128-189	Counterclockwise gobo rotation, slow → fast		
190-255	No rotation (90°)			
7		Rotating Gobos: Fine Indexing	Fade	0
	0-255	Gobo angle, fine		
8		Rotating Prisms: Function and Selection *see note 1	Snap	0
	0-31	Open (no prism)		
		<i>Prism indexing, set angle on ch. 9</i>		
	32-127	4-facet prism, indexed		
		<i>Prism rotation, set speed and direction on ch. 9</i>		
128-255	4-facet prism, rotating			
9		Rotating Prisms: Indexing and Speed	Fade	128
		<i>When indexed prism selected on ch. 9</i>		
	0-255	Prism angle, coarse, 0° → 360°		
		<i>When rotating prism selected on ch. 9</i>		
	0-31	No rotation (0°)		
	32-93	Clockwise rotation, fast → slow		
	94-127	No rotation		
128-189	Counterclockwise rotation, slow → fast			
190-255	No rotation (90°)			
10		Rotating Prism: Fine Indexing	Fade	0
	0-255	Indexed prism, fine control		

Channel	Value	Function	Fade type	Default value
11		Frost (Wash Mode) *see note 1	Snap	0
	0-127	No frost		
	128-255	Enable frost		
12		Focus, Coarse	Fade	128
	0-255	Focus, near → far		
13		Focus, Fine	Fade	0
	0-255	Fine focus adjustment		
14		Pan, Coarse	Fade	128
	0-255	Pan, 0° → 540°		
15		Pan, Fine	Fade	0
	0-255	Pan, fine control		
16		Tilt, Coarse	Fade	128
	0-255	Tilt, 0° → 270°		
17		Tilt, Fine	Fade	0
	0-255	Tilt, fine control		
18		Lamp On/Off, Reset, Personality Settings	Snap	0
	0-19	Reserved (no function)		
	20-29	Auto-Blackout ON		
	30-39	Auto-Blackout OFF (default)		
	40-59	Lamp ON (hold for 8s)		
	60-79	Lamp OFF (hold for 8s)		
	80-84	Reset all (hold for 3s)		
	85-87	Pan/tilt reset (hold for 3s)		
	88-90	Reset color wheel (hold for 3s)		
	91-93	Reset gobos (hold for 3s)		
	94-96	Reset shutter (hold for 3s)		
	97-99	Reset other effects (hold for 3s)		
	100-104	Control panel display ON (hold for 3s)		
	105-109	Control panel display OFF (hold for 3s)		
	110-115	Parameter shortcuts ON (default)		
116-121	Parameter shortcuts OFF			
122-255	Reserved (no function)			

*Note 1: You cannot use Frost and Prism at the same time due to mechanical restrictions inside the fixture. If you select Frost while Prism is in use, the prism will be removed. If you select Prism while Frost is in use, the frost will be removed.

Control menus

To access the control menus, press the MENU button. Use the UP and DOWN buttons to navigate the menus. Select a menu option with the ENTER button. For more information, see 'Using the control menus' on page 19.

Default fixture settings are shown in **bold**.

Menu	Sub-menu	Setting/Value		Explanation
DMX Function	DMX Address	001-492		Fixture DMX address setting
	DMX Value	PAN...		Displays DMX level of each channel
Information	Time Information	Total Use Time	XXXX(Hours)	Fixture running time in hours
		Lamp On Hours	XXXX(Hours)	Lamp hours (resettable)
		LampTime Password	XXX	Enter password 038 to reset lamp hours
		Reset Lamp Time	YES/NO	Reset lamp hours counter
	Head Temperature	XXX °C/°F		Displays head temperature in °C or °F
	Fan Info	2U_FAN1 : XXX RPM 2U_FAN2 : XXX RPM		Displays speed of each fan.
	Encode Feedback	PAN ENCODE: TILT ENCODE:		Feedback encoder level
Software Version	1U01.....V1.4.0 2U01.....V1.4.0		Displays software version of each PCB	
Lamp Setting	On/Off	ON/OFF		Manually switch lamp on/off
	State at Power	ON/OFF		Enable lamp on at power on
	On via DMX On	ON/OFF		Enable lamp on via DMX
	Off via DMX	ON/OFF		Enable lamp off via DMX
	Max On at Temp.	45° C (113° F)		Automatic lamp restart temperature (fixed setting)
	Lamp Off Temp.	130° C (266° F)		Automatic lamp off temperature (fixed setting)
Fixture Set	Loss of DMX	Black out /Hold		Black out/Hold @ DMX loss
	Status Settings	Pan inverse	ON/OFF	Reverse pan control
		Tilt inverse	ON/OFF	Reverse tilt control
		P/T Feedback	ON/OFF	Toggle pan/tilt correction
		Hibernation	OFF, 01M~99M	Set timing for standby mode
	Bl.O.P/T Move	ON/OFF		Blackout during pan or tilt
Bl.O.Other Move	ON/OFF		Blackout during color/gobo change	



Menu	Sub-menu	Setting/Value	Explanation	
Fixture Set	Display Setting	Display inverse	AUTO/ON/OFF	Flip display
		Backlight auto	02~60m 05m	Set delay time for display off
		Temperature Unit	Celsius/ Fahrenheit	Select unit for temp. display
		Display Warning	Error Record 1 Error Record 2	Toggle error code display
	Service Setting	Password	Password=XXX	Enter password to clear error codes
		RDM UID	XXXXXX	RDM UID
		Clear Err. Info	YES/NO	Clear Err. Info
	Factory settings	YES/NO		Reset fixture personalities to factory default values
Reset Function	Reset All		Perform a reset of selected effect(s)	
	Reset Pan&Tilt			
	Reset Colors			
	Reset Gobos			
	Reset Shutter			
	Reset Others			
Fixture Test	Auto Test		Perform automatic test of all functions	
	Manual Control	PAN =XXX :	Manually test each function	
Offsetting	Calibration Password Pan=-128..127 Tilt=-128..127 Color1=-128..127 :	0..255 0..255 0..255 :	Enter password to access offset menu Enter offset value to achieve home / open position	

Troubleshooting

This section describes a few common problems that may occur during operation and provides some suggestions for easy troubleshooting:

Symptom	Potential Causes	Remedies
No light from fixture, or fans not working.	Power supply issue such as blown fuse, faulty connector or damaged cable.	<p>Ensure that the mains supply is connected and supplying power to the fixture.</p> <p>Check all power connections and cables.</p> <p>Check and if necessary replace the fixture fuse.</p>
One of the control channels is unresponsive or only responds intermittently.	<p>DMX setup or DMX link fault.</p> <p>Damaged step motor or cable connection between head and body.</p>	<p>See next section.</p> <p>Contact your Martin authorized distributor or service center for assistance.</p>
Fixture does not respond to DMX control.	Fault in the DMX network due to connector or cable damage, incorrect DMX addressing, or potential interference from proximity to a high voltage installation.	<p>Ensure that fixture's DMX address matches address set on DMX control device.</p> <p>Check that fixture DMX LED is on, and if not, check all DMX cables and connections.</p> <p>Ensure that DMX link is terminated.</p> <p>Check that all components on DMX link use standard DMX polarity.</p> <p>Attempt to control the fixture with another DMX control device.</p> <p>Move or shield link if it is close to an unshielded high-voltage installation.</p>

Specifications

Physical

Dimensions (LxWxH).....301 x 408 x 560 mm (11.9 x 16.1 x 22.1 in.)

Weight 19.3 kg (42.5 lbs.)

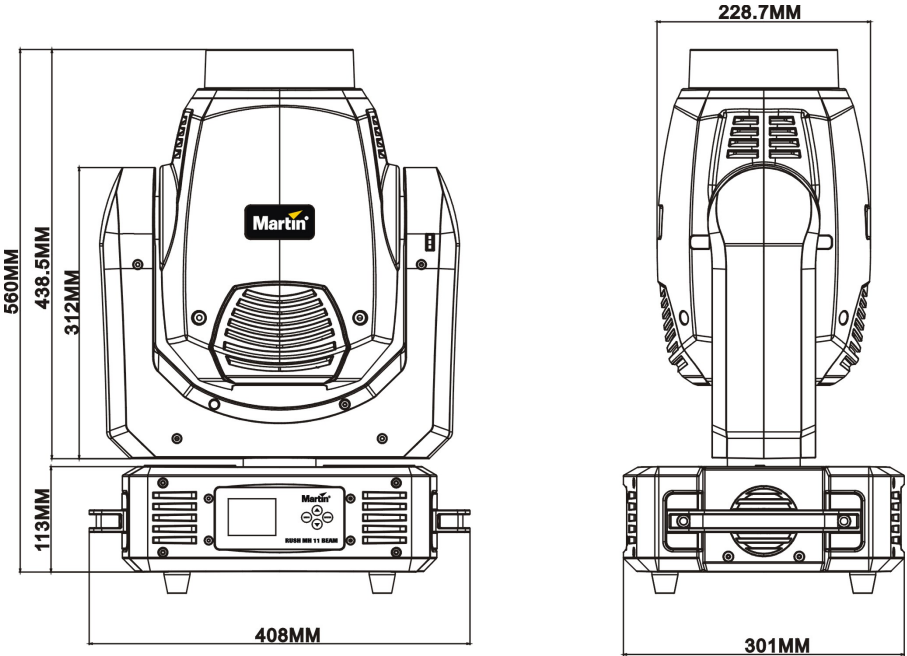

Lamp

Approved lamp Philips MSD Platinum 11R 250 W

Color temperature 7800 K

Average lifetime* 2000 hours

**Preliminary figure obtained under manufacturer’s test conditions*

Dynamic Effects

Dimming 0 – 100%, coarse & fine control

Shutter Strobe & pulse effects, instant open and blackout

Color wheel 10 colors plus CTO, CTB, UV & open

Rotating gobo wheel..... 8 gobos plus open, 16-bit indexing, continuous rotation and shake

Prism 8 facet, 16-bit indexing, variable rotation

Frost motorized, on/off

Focus..... Motorized, 16-bit coarse & fine control

Pan 540°, 16-bit coarse & fine control, position correction

Tilt 260°, 16-bit coarse & fine control, position correction

Optics

Beam angle 2.6°

Interchangeable Gobos

Acceptable materials Stainless steel or aluminum
Diameter 14 mm, +0/-0.2 mm (0.55 in., +0/-0.008 in.)
Max. image diameter, metal 9.5 mm (0.37 in.)
Thickness, metal 0.2mm (0.008 in.) nominal

Control and Programming

Control systems DMX, RDM
DMX channels 18
Integrated user interface Control panel with backlit LCD display
DMX compliance USITT DMX512/1990
RDM compliance ANSI/ESTA E.120

Construction

Color Black
Housing High impact flame retardant thermoplastic
IP rating IP 20

Installation

Mounting points Two quarter-turn brackets for rigging clamps
Location Dry location only, must be fastened to surface or structure
Orientation Any
Minimum distance to illuminated surfaces 10 m (33 ft.)
Minimum distance to combustible materials 20 cm (8 in.)
Minimum clearance around fans and vents 50 cm (20 in.)

Connections

AC power input/output Neutrik PowerCon TRUE1
DMX & RDM data in/out 3-pin & 5-pin locking XLR

Electrical

AC power 100-240 V nominal, 50/60 Hz
Typical half-cycle RMS inrush current 16A
Power supply unit Auto-ranging electronic switch mode
Fuse 5T 250 V 8.0 A

Typical power and current

90 V, 60 Hz 350 W, 3.9 A, PF 0.99
120 V, 60 Hz 345 W, 2.9 A, PF 0.98
230 V, 50 Hz 342 W, 1.5 A, PF 0.97
264 V, 50 Hz 340 W, 1.3 A, PF 0.97

Measurements made at nominal voltage. Figures are typical, not maximum, allow for a deviation of +/- 10%.

Thermal

Cooling	Forced air, temperature-regulated
Maximum ambient temperature (T_a max.).....	40° C (104° F)
Minimum ambient temperature (T_a min).....	0° C (32° F)
Total heat dissipation*	1430 BTU/hr.

*Calculated, +/- 10%, at full intensity, full white

Approvals



EU safety	EN 60598-2-17 (EN 60598-1), EN 62471, EN 62493
EU EMC.....	EN 55015; EN 55032; EN 55103-1,-2; EN 61000-3-2,-3; EN 61000-4-2, -4, -5; EN 61547
US safety	UL 1573
US EMC.....	CFR Title 47 Part 15 Class A
Canadian safety	CSA C22.2 No. 166
Canadian EMC	ICES-003 Class A
Australia/NZ.....	RCM (Pending)

Included Items

- Power cable, 1.5 m (4.9 ft.) without mains plug
- Two omega-type clamp attachment brackets with quarter-turn fasteners

Accessories

Installation hardware

Half-coupler clamp	P/N 91602005
G-clamp*	P/N 91602003
Quick-trigger clamp*	P/N 91602007
Safety cable, safe working load 60 kg, black	P/N 91604006
Safety cable, safe working load 60 kg, silver	P/N 91604007

*Use with fixture hanging vertically downwards only

Input cables, 16 A, for connection to power

Power Input Cable, H07RN-F, 2.5 mm ² , 14 AWG, Neutrik TRUE1 NAC3FX-W to bare ends, 1.5 m (4.9 ft.)	P/N 91611797
Power Input Cable, H07RN-F, 2.5 mm ² , 14 AWG, Neutrik TRUE1 NAC3FX-W to bare ends, 5 m (16.4 ft.)	P/N 91611786
Power Input Cable, SJOOW, AWG 12, Neutrik TRUE1 NAC3FX-W to bare ends, 1.5 m (4.9 ft.)	P/N 91610173
Power Input Cable, SJOOW, AWG 12, Neutrik TRUE1 NAC3FX-W to bare ends, 5 m (16.4 ft.)	P/N 91610174

Relay cables, 16 A, for relaying power in chains

- Power Relay Cable, H07RN-F, 2.5 mm²,
Neutrik TRUE1 to TRUE1, 0.45 m (1.5 ft.).....P/N 91611784
- Power Relay Cable, H07RN-F, 2.5 mm²,
Neutrik TRUE1 to TRUE1 1.2 m (3.9 ft.).....P/N 91611785
- Power Relay Cable, H07RN-F, 2.5 mm²,
Neutrik TRUE1 to TRUE1 2.5 m (8.2 ft.).....P/N 91611796
- Power Relay Cable, SJOOW, AWG 12,
Neutrik TRUE1 to TRUE1, 0.45 m (1.5 ft.).....P/N 91610170
- Power Relay Cable, SJOOW, AWG 12,
Neutrik TRUE1 to TRUE1, 1.2 m (3.9 ft.).....P/N 91610171
- Power Relay Cable, SJOOW, AWG 12,
Neutrik TRUE1 to TRUE1, 2.5 m (8.2 ft.).....P/N 91610172

Power connectors, cable mount

- Neutrik PowerCON TRUE1 NAC3MX-W (male).....P/N 91611788
- Neutrik PowerCON TRUE1 NAC3FX-W (female).....P/N 91611789



Related Items

RUSH® Software Uploader 2 M-DMX with MartinCompanion uploader software (see www.martin.com)

Ordering Information

RUSH® MH 11 Beam in cardboard boxP/N 90280110

Specifications subject to change without notice. For latest product specifications, see www.martin.com

	Disposing of this product
	Martin® products are supplied in compliance with Directive 2012/19/EC of the European Parliament and of the Council of the European Union on WEEE (Waste Electrical and Electronic Equipment), where applicable. Help preserve the environment! Ensure that this product is recycled at the end of its life. Your supplier can give details of local arrangements for the disposal of Martin products

Photobiological Safety Warning

The label shown below is displayed on this product. If it becomes difficult or impossible to read, it must be replaced using the illustration below to reproduce a new label sized 88 x 43, in black on a yellow background.

