

EN Operating and installation instructions PKFI11, PKFI11AB

BORA Pro surface induction glass ceramic cooktop
with 2 cooking zones

BORA Pro surface induction glass ceramic cooktop
with 2 cooking zones All Black

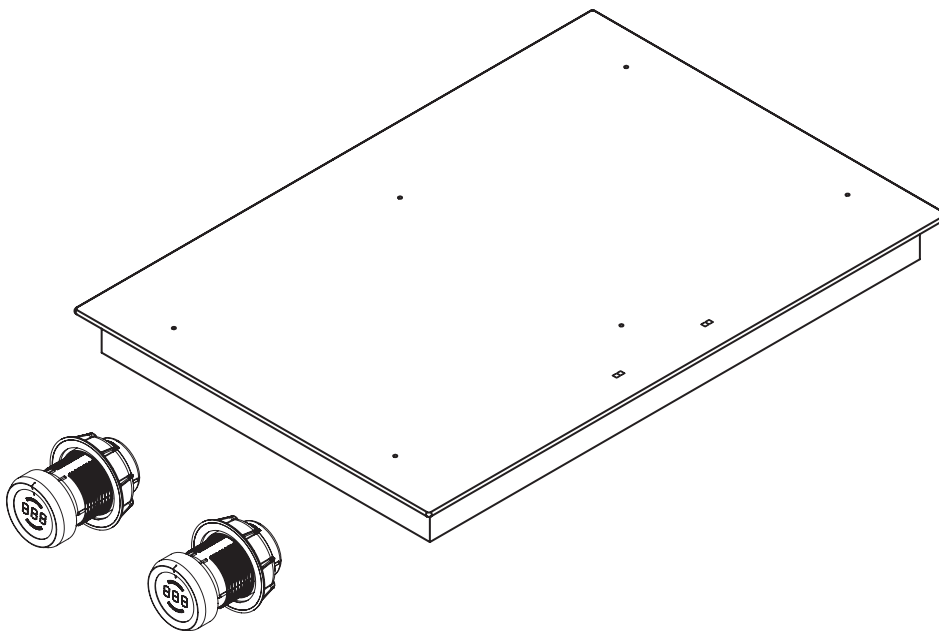

PKFI11UMEN-007

Operating and installation instructions:

Original

Translation

Manufacturer

BORA Vertriebs GmbH & Co KG

Innstraße 1
6342 Niederndorf
Austria

Contact

T +43 (0) 5373 / 62250-0
mail@bora.com
www.bora.com

The distribution and duplication of this document, as well as the use and disclosure of its contents are prohibited unless expressly authorised.

These operating and installation instructions have been drawn up with the greatest of care. But it cannot be ruled out that subsequent technical modifications have not yet been incorporated or the relevant content has not yet been adapted. Please accept our apologies in this eventuality. An updated version can be requested from the BORA Service Team. Subject to printing errors and mistakes.

© BORA Vertriebs GmbH & Co KG

All rights reserved.

Table of Contents

1	General information	4	6	Operation	25
1.1	Target group.....	4	6.1	General operating instructions.....	25
1.2	Validity of the operating and installation instructions.....	4	6.2	Operating the cooktop.....	25
1.3	Other applicable documents.....	4	6.2.1	Switching on the cooking zone.....	25
1.4	Presentation of information.....	5	6.2.2	Power setting.....	25
2	Safety	6	6.2.3	Bridging function.....	26
2.1	General safety instructions.....	6	6.2.4	Automatic heat up function.....	26
2.2	Safety instructions – Cooktop operation.....	7	6.2.5	Switching off the automatic heat up function... ..	26
2.3	Safety Instructions – Installation.....	9	6.2.6	Heat retention level.....	26
2.4	Safety instructions – Cleaning and Maintenance.....	9	6.2.7	Childproofing feature.....	27
2.5	Safety instructions – disassembly and disposal.....	10	6.2.8	Using the timer function.....	27
2.6	Safety instructions – spare parts.....	10	6.2.9	Pause function.....	28
2.7	Use as intended.....	10	6.2.10	Switching off the cooking zone.....	28
3	Technical data	11	7	Cleaning and Maintenance	29
4	Device description	12	7.1	Cleaning agents.....	29
4.1	Structure.....	12	7.2	Looking after the cooktop.....	29
4.2	Operating principle.....	12	7.3	Cleaning the cooktop.....	29
4.3	Functional principle.....	13	7.4	Cleaning the control knobs.....	30
4.3.1	Power levels.....	13	7.4.1	Cleaning the knob ring.....	30
4.3.2	Power setting.....	13	7.4.2	Cleaning the touch surface and the knob housing.....	30
4.3.3	Automatic heat up function.....	14	8	Troubleshooting	31
4.3.4	Heat retention levels.....	14	9	Decommissioning, disassembly and disposal	32
4.3.5	Bridging function.....	14	9.1	Decommissioning.....	32
4.3.6	Suitable cookware.....	14	9.2	Disassembly.....	32
4.3.7	Pan size recognition.....	14	9.3	Environmentally-friendly disposal.....	32
4.3.8	Timer functions.....	15	10	Warranty, technical service, spare parts, accessories	33
4.3.9	Pause function.....	15	10.1	BORA manufacturer's warranty.....	33
4.4	Safety devices.....	15	10.2	Service.....	33
4.4.1	Residual heat display.....	15	10.3	Spare parts.....	33
4.4.2	Safety shut-down.....	15	10.4	Accessories.....	33
4.4.3	Overheating protection.....	15	11	Notes	34
4.4.4	Childproofing feature.....	15			
5	Installation	16			
5.1	Checking the delivery.....	16			
5.2	Tools and aids.....	16			
5.3	Assembly instructions.....	16			
5.3.1	Safety clearances.....	16			
5.3.2	Worktop and kitchen units.....	16			
5.3.3	Recirculation when using the cooktop extractor as a recirculation system.....	17			
5.4	Cut-out dimensions.....	17			
5.4.1	Flush installation.....	17			
5.4.2	Surface mounting.....	18			
5.5	Installing the cooktop.....	18			
5.5.1	Installing the control knob in the floor unit front panel.....	18			
5.5.2	Installing the cooktop.....	20			
5.5.3	Installation rotated by 180°.....	20			
5.5.4	Establishing communication.....	21			
5.5.5	Establishing the power connection.....	22			
5.6	Configuration menu.....	23			
5.6.1	Accessing the configuration menu.....	23			
5.6.2	Select menu option.....	23			
5.6.3	Changing the set value.....	24			
5.6.4	Exiting the configuration menu.....	24			
5.7	Sealing the devices.....	24			
5.8	Handover to user.....	24			

1 General information

1.1 Target group

These operating and installation instructions apply for the following target groups:

Target group	Requirements
User	The appliance can be used by children aged 8 and above as well as people with reduced physical, sensory or mental capacities or a lack of experience and/or knowledge if they are supervised or have been instructed how to safely use the appliance and understand the resultant risks. Children must be supervised. All safety and warning information and the handling instructions in the installation instructions must be complied with.
Ambitious DIYers	Ambitious DIYers can independently conduct all joinery and installation work providing they possess the necessary skills and expertise. They must never independently establish electricity and gas connections.
Installation specialists	Installation specialists are authorised to conduct all joinery and installation work in line with existing regulations. The electricity and gas connections must be certified by a certified engineer for the applicable trade prior to commissioning.
Electricians	The electrical connection may only be established by a certified engineer. He/she also assumes responsibility for the proper electrical installation and commissioning.
Gas specialists	The gas connection may only be established by certified engineers. They also assume responsibility for proper installation and commissioning of the gas system.

Tab. 1.1 Target groups

INFO BORA Holding GmbH, BORA Vertriebs GmbH & Co KG, BORA APAC Pty Ltd and BORA Lüftungstechnik GmbH - hereinafter referred to as BORA - do not assume any liability for damage arising from non-adherence to these documents and from improper assembly! The electricity and gas connections must be made by a qualified specialist. Installation must comply with the valid standards, regulations and laws. All safety and warning information and the operating and installation instructions must be complied with.

1.2 Validity of the operating and installation instructions

These instructions apply to several device versions. It is therefore possible that some of the features described do not apply to your appliance.

1.3 Other applicable documents

These operating and installation instructions are valid in conjunction with other documents, which must be adhered to.

Please be sure to adhere to all documents that form part of the scope of delivery.

INFO BORA accepts no liability for damage caused by failure to comply with these documents!

Directives

This device meets the following EU/EC directives:

2014/30/EU EMC Directive
 2014/35/EU Low Voltage Directive
 2009/125/EC Ecodesign Directive
 2011/65/EU RoHS Directive

1.4 Presentation of information

To make working with these instructions quick and easy, consistent formatting, numbering, symbols, safety instructions, terms and abbreviations are used throughout.

Handling instructions are marked with an arrow.

- ▶ Always carry out handling instructions in the sequence shown.

Bullet points are indicated by a square bullet point at the edge of the line.

- Bullet point 1
- Bullet point 2

INFO Information points out specific points you must always comply with.

Safety and warning information

The safety and warning information in these instructions are highlighted with symbols and signal words.



Safety and warning information is structured as follows:

WARNING SYMBOL AND SIGNAL WORD!

- Type and source of the danger
 - Consequences of non-compliance
 - ▶ Measures to minimise risk
-

The following applies:

- The warning symbol draws attention to the danger.
- The signal word indicates the severity of the risk.

Warning sign	Signal word	Hazard
	Danger	Indicates an imminent hazardous situation which could lead to death or serious injury if ignored.
	Warning	Indicates an imminent hazardous situation which could lead to death or serious injury if ignored.
	Caution	Indicates a potentially hazardous situation which could lead to slight or minor injuries if ignored.
–	Caution	Indicates a situation which could result in material damage if ignored.

Tab. 1.2 Meaning of warning symbols and signal words

2 Safety

2.1 General safety instructions

INFO The appliance complies with the stipulated safety requirements. The user is responsible for appliance cleaning and maintenance as well as its safe use. Improper use can lead to personal injury and damage to property.

- The operating and installation instructions contain important information about installation and operation. These enable you to protect yourself against injuries and prevent damage to the appliance. Contact details for further information as well as application and usage questions can be found on the back of these operating and installation instructions.
- The term “appliance” is used to refer to cooktops, cooktop extractors or cooktops with integrated cooktop extractor.
 - ▶ Read the operating and installation instructions fully before using the appliance for the first time.
 - ▶ Always store the operating and installation instructions within easy reach so that they can be accessed if required.
 - ▶ Pass the operating and installation instructions to the next owner if you sell the appliance.
 - ▶ Conduct all work extremely attentively and conscientiously.
 - ▶ Check the appliance for visible damage when unpacking it.
 - ▶ Do not connect a damaged appliance.
 - ▶ Do not connect the appliance to the mains until the duct system has been installed or the recirculation filter has been fitted.
 - ▶ Only use the connection cables supplied in the scope of delivery.
 - ▶ Do not use the appliance until installation is complete. This is the only way to ensure safe operation.
 - ▶ Make sure contact with hot cooking surfaces is not possible.
 - ▶ Do not place any objects on the operating panel or the cooktop extractor air inlet nozzle.
 - ▶ Switch off the appliance after use.
 - ▶ Keep pets away from the appliance.

CAUTION!

Appliance components can cause injury if dropped!

Appliance components such as pan supports, operating controls, covers, grease filters, etc. can cause injury if dropped.

- ▶ Place any appliance components that have been removed in a safe place near the appliances.
- ▶ Ensure that no components removed from the appliance can fall on the floor.

Unauthorised modifications

Unauthorised modifications can cause the appliance to pose risks.

- ▶ Do not make any changes to the appliance.

Households with children and people with special needs

- ▶ The appliance can be used by children aged 8 and above as well as people with reduced physical, sensory or mental capacities or a lack of experience and/or knowledge if they are supervised or have been instructed how to use the appliance safely and understand the resultant risks.
- ▶ Supervise children in the vicinity of the appliance.
- ▶ Children must not play with the appliance.
- ▶ Use the childproofing feature in order to prevent children from switching on the cooktop or changing the settings when they are unattended.
- ▶ Do not store any items that could be of interest to children in storage spaces above or behind the appliance. Otherwise, they will be tempted to climb onto the appliance.
- ▶ Keep children and other persons away from the cooking surfaces when hot.

Recirculation mode

INFO When cooking, additional moisture is released into the ambient air.

INFO In recirculation mode, only a slight amount of moisture is removed from the cooking vapour.

- ▶ When using recirculation mode, ensure a sufficient supply of fresh air, e.g. by opening a window.
- ▶ Ensure a normal and comfortable room climate (humidity of 45–60%), e.g. by opening natural ventilation openings or using domestic ventilation systems.
- ▶ After every use in recirculation mode, switch the cooktop extractor to a low level for about 20 minutes or activate the automatic after-run function.

Faults and errors

- ▶ Observe the information in the Troubleshooting chapter.
- ▶ In the event of any faults or errors that are not covered, switch the appliance off.

2.2 Safety instructions – Cooktop operation

- ▶ Avoid over-cooking.
- ▶ Pay attention to the residual heat display.
- ▶ Do not place any hot cookware in the area of the cooktop display so as not to damage the underlying electronics.
- ▶ Make sure that the base of the cookware as well as the cooking zones are clean and dry.
- ▶ Always lift (do not drag!) the cookware to prevent scratching and abrasion on the surface.



DANGER!

Danger of fire caused by leaving the cooktop unattended!

Oil or fat in the pot can quickly heat up and ignite.

- ▶ Never leave oil or fat to heat up unattended.
- ▶ Never extinguish oil and fat fires with water.
- ▶ Suffocate the fire, for example by using a lid.



DANGER!

Risk of explosion caused by flammable liquids!

Flammable liquids in the vicinity of the cooktop can explode and cause serious injury.

- ▶ Do not spray aerosols in the vicinity of this appliance while it is in operation.
- ▶ Do not place any flammable liquids in the vicinity of the cooktop.



DANGER!

Risk of electric shock!

Cracks, fissures or fractures in the glass ceramic panel can damage the underlying electronics. This can cause an electrical shock.

- ▶ If there are any cracks, fissures or fractures in the glass ceramic, switch the appliance off immediately.
- ▶ Securely disconnect the appliance from the mains using the LS switch, fuses, automatic circuit breakers or contactor.



WARNING!

Risk of burns from hot cooktop!

The cooktop and its exposed areas get hot during use. Once the cooking zone is switched off, it takes a little while to cool down to below 60 °C. Touching hot surfaces can cause serious burns.

- ▶ Never touch the cooktop when it is hot.
- ▶ Keep children away from the cooktop when it is hot or ensure they are supervised at all times.



WARNING!

During or after a power cut, cooktops may still be hot!

In the event of a power cut, a cooktop that was previously in operation may still be hot even though there is no indication of residual heat.

- ▶ Do not touch the cooktop while it is still hot.
- ▶ Keep children away from the hot cooktop.



WARNING!

Risk of fire from objects on the cooking surfaces!

The cooktop and its exposed parts are hot when the cooking zone is switched on and during the cooling phase. Objects on the cooktop can heat up and catch fire.

- ▶ Do not place any items on the cooktop.

**WARNING!****Risk of burns from hot objects!**

The cooktop and its exposed parts are hot when the cooktop is in use and during the cooling phase. Objects on the cooktop heat up very quickly and can cause serious burns. This particularly applies to metal objects (e.g. knives, forks, spoons, lids or cooktop extractor covers).

- ▶ Do not place any items on the cooktop.
- ▶ Please use suitable tools (pot holders, oven gloves).

**WARNING!****Risk of burns from hot cookware!**

Handles projecting over the edge are enticing for children to grab.

- ▶ Do not turn pot and pan handles so they stick out beyond the work surface.
- ▶ Make sure that children cannot pull hot pots and pans over.
- ▶ Use suitable stove guards.
- ▶ Do not use unsuitable stove guards (accident risk).
- ▶ To choose a suitable stove guard, contact your specialist supplier or the BORA Service Team.

**WARNING!****Risk of burns!**

Liquid between the cooking zone and the pan base can evaporate and cause burns.

- ▶ Make sure that the cooking zone and the pan base are always dry.

CAUTION!**Damage from hard and pointed objects!**

Hard and pointed objects can damage the glass ceramic panel of the cooktop.

- ▶ Do not use the surface of the cooktop as a worktop.
- ▶ Do not use hard and pointed objects when working on the cooktop.

CAUTION!**Damage from sugary and salty foods!**

Sugary and salty foods and juices can damage the hot cooking zone.

- ▶ Make sure sugary and salty foods or juices do not get onto the cooking zone while it is hot.
- ▶ Remove sugary and salty foods and juices from the hot cooking zone immediately.

CAUTION!**Escaping hot liquids!**

Unattended pans can boil over allowing hot liquids to escape.

- ▶ Always keep an eye on pans while cooking.
- ▶ Short cooking sessions must be constantly monitored.

CAUTION!**Damage caused by objects on the cooktop!**

Objects such as cookware lids on the cooktop can damage the glass ceramic panel.

- ▶ Do not place any objects on the cooktop while it is hot.

2.2.1 Safety instructions – cooktop installation

- ▶ Do not rely on the pan size recognition.

Effect on pace makers, hearing aids and metal implants

INFO

Induction cooktops generate a high-frequency electromagnetic field in the area of the cooking zones. The cooking zones may affect pacemakers, hearing aids or metal implants negatively or disturb their function when in close proximity. A reduced function of the pacemaker is unlikely.

- ▶ If in doubt, contact the manufacturer of your medical device or your doctor.

2.3 Safety Instructions – Installation

The appliance must only be installed and assembled by trained specialists who are familiar with and comply with the standard national regulations and supplementary regulations of the local utility companies.

Work on electrical components must be conducted by trained electrical personnel.

The electrical safety of the appliance is only guaranteed if it is connected to a protective conductor system that has been installed in line with regulations. Ensure that this basic safety precaution is met.

- ▶ Check the appliance for visible damage prior to installation.
- ▶ Do not install any damaged appliance.
- A damaged appliance may put your safety at risk.

Repair and maintenance work may only be carried out by specialists authorised by the manufacturer.



DANGER!

Risk of asphyxiation!

Packaging components (e.g. film, polystyrene) can be life-threatening for children.

- ▶ Store all packaging components out of reach of children.
- ▶ Dispose of the packaging properly and immediately.

2.3.1 Safety Instructions – Cooktop installation



DANGER!

Risk of electric shock!

Connecting the appliance to the mains incorrectly poses a risk of electric shock.

- ▶ Make sure that the appliance has a fixed connection to the mains voltage.
- ▶ Make sure that the appliance is connected to a properly installed protective conductor system.
- ▶ Make sure that technical equipment is provided to enable all of the appliance's poles to be disconnected from the mains with a contact opening width of at least 3 mm (LS switch and automatic circuit breakers, fuses, contactor).



DANGER!

Risk of electric shock!

The connection cable can be damaged if it comes into contact with hot cooking zones. A damaged connection cable can cause a (fatal) electrical shock.

- ▶ Make sure that the connection cable does not come into contact with hot cooking surfaces.
- ▶ Make sure that the connection cable does not become trapped or damaged.



CAUTION!

Lifting heavy loads can cause back injuries!

If not handled correctly, removing and installing the appliance can cause injuries to the limbs or torso.

- ▶ Removing the cooktop from the packaging is a two-person job.
- ▶ Placing the cooktop into the worktop cut-out is a two-person job.
- ▶ Use appropriate aids to prevent damage or injuries to limbs or torso.

2.4 Safety instructions – Cleaning and Maintenance

The appliance must be cleaned at regular intervals. Dirt can lead to damage or bothersome odours. Remove dirt immediately.

- Any work involving cleaning and maintenance must not be carried out by children unless they are supervised at all times while doing so.
- ▶ Do not use a steam cleaner for cleaning. Steam can cause a short circuit on live parts and thus lead to property damage (see the Cleaning and Maintenance chapter).
- ▶ When cleaning, ensure that no water penetrates the appliance. Use only a slightly damp cloth. Never spray the device with water. Water penetration can cause damage!
- ▶ Whenever possible, clean the cooktop after every use.
- ▶ Clean the cooktop only after it has cooled down.
- ▶ When cleaning, only use non-abrasive detergents to prevent scratching and abrasion on the surface.

2.5 Safety instructions – disassembly and disposal

The appliance must only be disassembled by trained specialists who are familiar with and comply with the standard national regulations and supplementary regulations of the local utility companies.

Work on electrical components must only be conducted by trained electrical personnel.



DANGER!

Risk of electric shock!

Incorrectly disconnecting the appliance from the mains results in a risk of electric shock.

- ▶ Securely disconnect the appliance from the mains using LS switches, fuses, automatic circuit breakers or contactors.
- ▶ Use an authorised measuring device to ensure that there is no power to the appliance.
- ▶ Do not touch exposed contacts on the electronic unit as they can contain residual charge.

2.6 Safety instructions – spare parts



WARNING!

Risk of injury and damage to property!

Incorrect components can lead to personal injury or damage to the appliance. Modifications, additions or alterations to the appliance can lead to safety risks.

- ▶ Only use original spare parts for repairs.

INFO

A damaged power supply cable must be replaced by a suitable power supply cable. This may only be done by an authorised member of the After Sales Service team.

2.7 Use as intended

The appliance cannot be used at altitudes above 2,000 m (metres above sea level).

The appliance is solely intended for preparing food in private households. This appliance is not intended for:

- Outdoor use
- Installation in vehicles
- Heating rooms
- Use in non-stationary installation sites (e.g. on ships)
- Use with an external timer or a separate remote control system (remote operation)

Any use other than that specified in these operating and installation instructions or any use that goes beyond that which is described here is classed as unintended. BORA does not assume any liability for damages caused by improper use or incorrect operation.

All misuse is prohibited!

INFO

BORA Holding GmbH, BORA Vertriebs GmbH & Co KG, BORA APAC Pty Ltd and BORA Lüftungstechnik GmbH do not assume any liability for damage arising from non-adherence to the safety and warning information.

3 Technical data

Parameter	Value
Supply voltage	220 - 240 V
Frequency	50/60 Hz
Power consumption	3.7 kW
Fuse protection	1 x 16 A
Dimensions (width x depth x height)	370 x 540 x 52 mm
Weight (incl. accessories/ packaging)	8.1 kg
Cooktop	Value
Power levels	1 - 9, P
Heat retention levels	3
Front cooking zone Power setting	230 x 230 mm 2100 W 3700 W
Rear cooking zone Power setting	230 x 230 mm 2100 W 3700 W
Cooktop energy consumption	Value
Front cooking zone	230 x 230 mm 182.2 (Wh/kg)
Back cooking zone	230 x 230 mm 181.1 (Wh/kg)
Cooking zones bridged	230 x 460 mm 207.0 (Wh/kg)
Total (average)	190.1 (Wh/kg)

Tab. 3.1 Technical data PKFI11

Device dimensions control knob

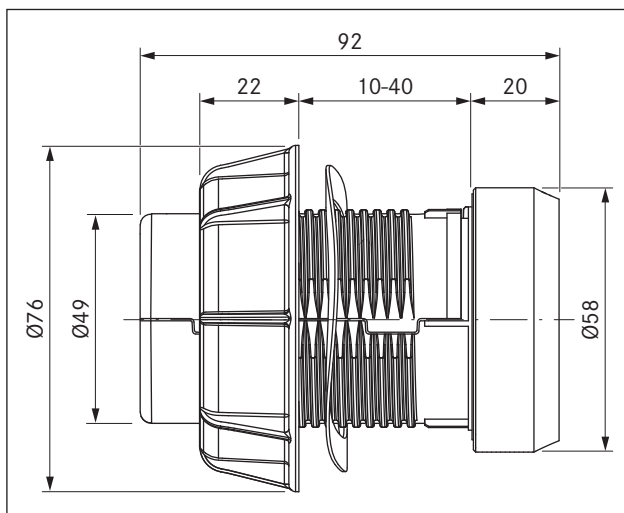

Fig. 3.1 Device dimensions control knob

Device dimensions cooktop

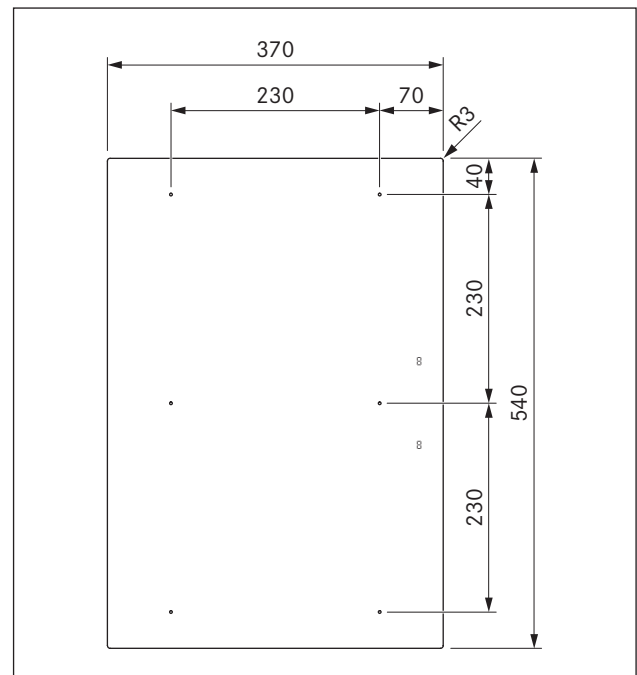

Fig. 3.2 PKFI11 Device dimensions aerial view

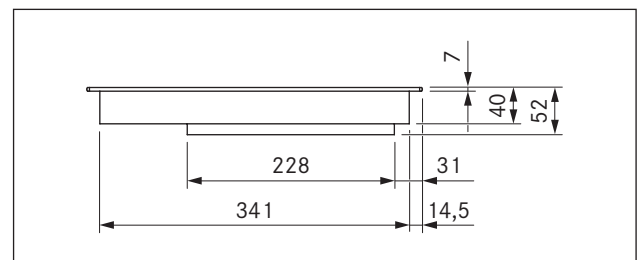

Fig. 3.3 PKFI11 Device dimensions front view

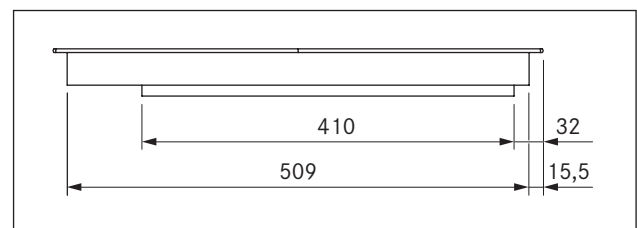

Fig. 3.4 PKFI11 Device dimensions side view

4 Device description

Observe all safety and warning information during operation (see the Safety section).

The cooktop has the following features:

- Automatic heat up function
- Safety shut-down
- Bridging function
- Electronic power control (9 levels)
- Power setting
- Childproofing feature
- Residual heat display
- Pause function
- Pan size recognition
- Heat retention levels
- Cooking zone indicator

4.1 Structure

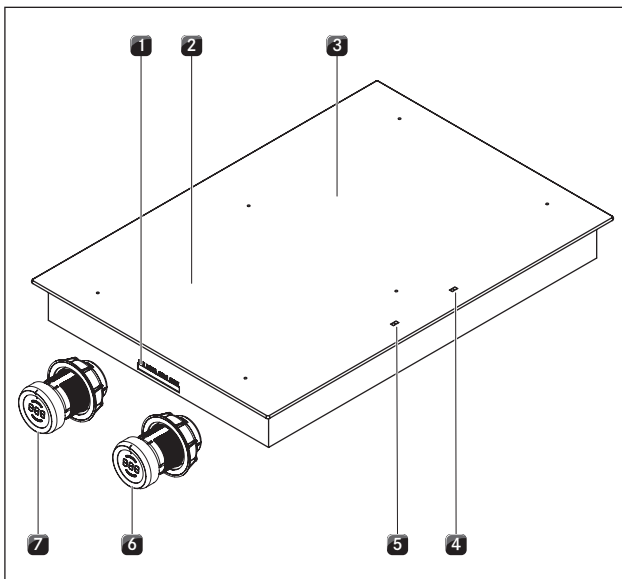

Fig. 4.1 Cooktop

- [1] Connections for control knob and extraction system
- [2] Front surface induction cooking zone (zone 1)
- [3] Back surface induction cooking zone (zone 2)
- [4] Rear cooking zone indicator (zone 2)
- [5] Front cooking zone indicator (zone 1)
- [6] Control knob for the back cooking zone (zone 2)
- [7] Control knob for the front cooking zone (zone 1)

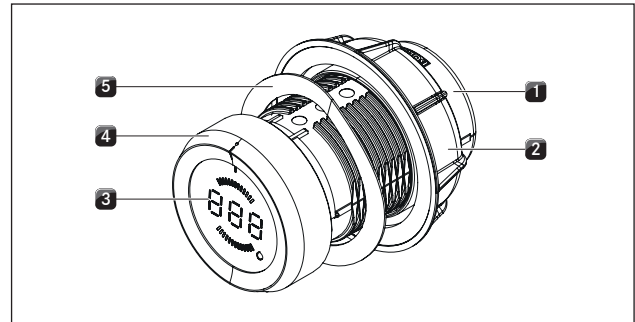

Fig. 4.2 Structure of control knob

- [1] Knob casing
- [2] Universal nut
- [3] Control knob display
- [4] knob ring
- [5] Wave spring

4.2 Operating principle

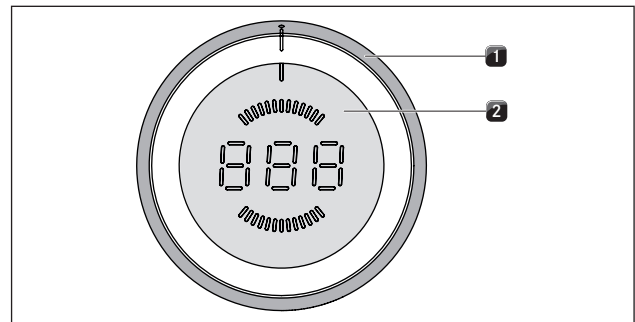

Fig. 4.3 Control elements of control knob

- [1] knob ring
- [2] Touch surface

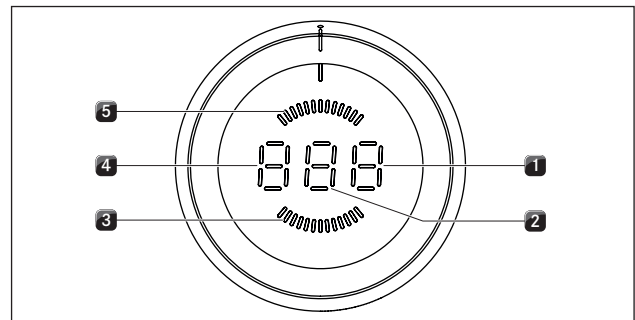

Fig. 4.4 Control knob display elements

- [1] Display of functions
- [2] Power display
- [3] Front cooking zone display
- [4] Display of mode or operating mode
- [5] Rear cooking zone display

Knob operation

All the cooking zones are controlled using a control knob. By twisting the control knob and pressing the touch surface, the power levels and functions for the relevant cooking zone are controlled (see Operation section).

7-segment display

Display	Meaning	Control knob display	Cooking zone indicator
□	Cooktop switching off	✓	✓
1 - 9	Power levels	✓	✓
P	Power setting	✓	✓
u	Heat retention level	✓	
- / = / ∞	Active heat retention levels	✓	✓
P	Automatic heat up function	✓	✓
P	Bridging function	✓	✓
H	Residual heat display: Cooking zone is switched off but still hot (temperature > 60°C)	✓	✓
L	Childproofing feature	✓	✓
	Pause function	✓	✓
u	Pan size recognition	✓	✓
E ...	Error message (see Troubleshooting section)	✓	✓
t	Short-time timer function (egg timer)	✓	
⌂	Configuration menu	✓	

Tab. 4.1 Meaning of display

4.3 Functional principle

An induction coil is located underneath an induction cooking zone. If the cooking zone is switched on, this coil creates a magnetic field that acts directly on the base of the pot thus heating it up. The cooking zone is only indirectly heated up by the heat emitted by the pot. Cooking zones with induction only work if the cookware has a magnetisable base.

The induction automatically takes into account the size of the used cookware which means that only the area in the cooking zone covered by the base of the pot is heated up.

► Observe the minimum pot base diameter.

4.3.1 Power levels

The high power output of induction cooktops results in the very quick heating up of cookware. A slight adjustment is needed in comparison to conventional cooking systems when selecting the power level in order to avoid burning food.

Activity	Power level
Melting of butter and chocolate, breaking up gelatine	1
Keeping sauces and soups warm, soaking rice	1 - 3
Cooking potatoes, pasta, soups, ragouts, steaming fruit, vegetables and fish, defrosting food	2 - 6
Frying in coated pans, moderate frying (without overheating the fat) of pork cutlets, fish	6 - 7
Heating up fat, browning fish, cooking thickened sources and soups, making omelettes	7 - 8
Cooking large quantities of liquid, browning steaks	9
Heating up water	P

Tab. 4.2 Recommendations for power levels

The specifications provided in the table are standard values.

Depending on the cookware and filling quantity, it is recommended to either decrease or increase the power level.

4.3.2 Power setting

The two cooking zones are equipped with a power-enhancing power setting.

■ P is displayed.

The power setting can be used in order to quickly heat up large quantities of water. If the power setting is activated, the cooking zone will run at extra high power. After 10 minutes, the cooking zone is automatically switched to power level 9.

If the bridging function is activated, the power setting cannot be used.

INFO Never heat up oil, fat and the like at this power setting. The bottom of the pan can overheat due to the high power output.

4.3.3 Automatic heat up function

The two cooking zones are equipped with an automatic heat up function that can be switched on and off.

■ \bar{A} is displayed.

This function enables the cooking zone to work at full power for a certain duration after switching on. After this time, the power level is automatically switched back to the power level set.

Power level	Cooking duration in min:sec
1	0:40
2	01:00
3	02:00
4	03:00
5	04:20
6	07:00
7	02:00
8	03:00

Tab. 4.3 Overview of the automatic heat up function

4.3.4 Heat retention levels

The heat retention level keeps cooked foods warm.

■ \cup appears in the control knob display.

■ The maximum duration for the warming function is limited to 8 hours.

There are three different heat retention levels.

Heat retention level	Symbol	Temperature
1	-	42° C
2	=	74° C
3	≡	94° C

Tab. 4.4 Heat retention levels

4.3.5 Bridging function

The two cooking zones can be operated as a connected cooking zone at the same power level.

■ \bar{B} is displayed.

The bridging function is suitable for heating food in a roaster.

4.3.6 Suitable cookware

INFO The heating and heat through time for the base of the cookware as well as the cooking results are significantly influenced by the structure and material of the cookware.



Cookware with this symbol is suitable for induction cooktops. The cookware used for the induction cooktop must be made of metal, feature magnetic properties and possess a sufficient bottom surface.

Suitable cookware is made of:

- stainless steel with a magnetisable base
- enamelled steel
- cast iron

Cooking zone	Minimum diameter
front back	120 mm 120 mm

Tab. 4.5 Minimum cookware diameter

- ▶ Perform a magnet test, if necessary. If a magnet sticks to the base of the utensils, they are normally induction compatible.
- ▶ Pay attention to the cookware bottom. The base of the cookware should not show any sign of curvature. Due to incorrect temperature monitoring of the hob caused by the air gap between the cookware and the temperature sensor underneath the hob, overheating may occur. The bottom of the cookware must not have any sharp grooves or sharp edges to avoid scratching the cooktop.
- ▶ Place the cookware (without a mat or similar) directly onto the glass ceramic.

Noises

The following noises may occur in the cookware when using induction cooking zones, depending on the material and the finish of the base:

- **Humming** may occur when using a high power level. It decreases or disappears if the power level is decreased.
- **Crackling or whistling** may occur due to the bases of cookware made of different materials (e.g. sandwich base).
- **Clicking sounds** may occur during electronic switching procedures especially at low power levels.
- **Whirring** may occur when the cooling fan is switched on. In order to increase the service life of the electronic system, the cooktop is equipped with a cooling fan. The cooling fan switches on automatically if the cooktop is used intensively. You will hear a whirring sound. The cooling fan may continue running after the device has been switched off.

4.3.7 Pan size recognition

The cooking zone is not working when ...

- ... \bar{C} is displayed.
- ... it is switched on without cookware or with unsuitable cookware.
- ... the base diameter of the cookware is too small;
- ... the cookware is removed from a switched on cooking zone.
- ... no pan is detected after 10 minutes. The cooking zone then switches off automatically and can only be switched back on after the control knob has been turned back to the zero position.

4.3.8 Timer functions

There are two different timer functions for each cooking zone.

■ t appears in the control knob display.

INFO You can set a time range of between 1 and 120 minutes for the timer functions.

Timer function

INFO The timer function is an automatic cut-off which automatically switches off a cooking zone which is in use.

Short-time timer (egg timer)

INFO The short-time timer requires the cooking zone to be switched off and works like a conventional egg timer.

4.3.9 Pause function

The cooking session can be temporarily interrupted (max. 10 minutes).

■ $||$ is displayed.

4.4 Safety devices

4.4.1 Residual heat display

INFO While H is displayed (residual heat display), do not touch the cooking zone or place any heat-sensitive objects on top of it.
Risk of burns and fire!

After switching it off, the cooking zone remains hot. H is displayed (residual heat display). The display goes out after a sufficient cooling time (temperature < 60 °C).

4.4.2 Safety shut-down

Each cooking zone is switched off automatically when the cooking zone in the power level or heat retention level exceeds the maximum operating duration. H is displayed (residual heat display).

Power level	Switch off after hours:minutes
1	08:24
2	06:24
3	05:12
4	04:12
5	03:18
6	02:12
7	02:12
8	01:48
9	01:18
P	00:10

Tab. 4.6 Safety shut-down for power levels

Heat retention level	Switch off after hours:minutes
1 (-)	08:00
2 (=)	08:00
3 (≡)	08:00

Tab. 4.7 Safety shut-down for heat retention levels

► Switch the cooking zone back on (see Operating section) if you want to put the cooking zone back into operation.

4.4.3 Overheating protection

INFO If the cooktop overheats, the power is reduced or the cooktop is switched off completely.

The device is fitted with overheating protection. The overheating protection can be triggered if:

- Cookware is heated up empty.
 - Oil or fat is heated on high power.
 - A hot cooking zone is switched on again after a power cut.
- Whilst the overheating protection is active, one of the following steps is taken:
- The activated power setting is switched back to the previous level.
 - The power setting P can no longer be switched on.
 - The set power level is reduced.
 - The cooktop switches off completely.

After a sufficient cooling period, the cooktop can be used again in full.

4.4.4 Childproofing feature

The childproofing feature prevents the cooktop from being switched on accidentally.

■ L is displayed.

The childproofing feature can only be activated when all the cooking zones are switched off (see the Operation section).

5 Installation

- ▶ Observe all safety and warning information (see the Safety chapter).
- ▶ Follow the enclosed manufacturer's information.

INFO The cooktop must not be installed above cooling devices, dishwashers, stoves, ovens, washing machines or driers.

INFO The contact surface of the worktops and wall sealing strips must be made of a heat-resistant material (up to approx. 100 °C).

INFO Worktop cut-outs must be moisture-sealed using suitable means or, where necessary, fitted with a thermal insulator.

INFO Control knobs must only be connected to the cooktop extractor connections provided.

5.1 Checking the delivery

Name	Quantity
Cooktop	1
Control knob	2
Operating and installation instructions	1
Cooktop mounting screws	4
Height adjustment plate set	1
Cooktop mounting straps	4
Control knob cable	2
Automatic extraction system cable	1
Glass ceramic cleaning instructions	1
Glass ceramic scraper	1

Tab. 5.1 Scope of delivery

- ▶ Check the delivery for damage and make sure it is complete.
- ▶ If there are any missing or damaged parts, please notify BORA After Sales Service immediately.
- ▶ Do not under any circumstances install parts which are damaged.
- ▶ Dispose of transport packaging in the proper manner (see the Decommissioning and Disposal chapter).

5.2 Tools and aids

The following tools are required for the correct installation of the cooktop:

- Pencil
- Measuring tool
- Drill or cordless drill with 50 mm Forstner bit
- Screwdriver/Torx screwdriver 20
- Silicone sealant for sealing cutting surfaces

5.3 Assembly instructions

5.3.1 Safety clearances

- ▶ Maintain the following safety clearances:

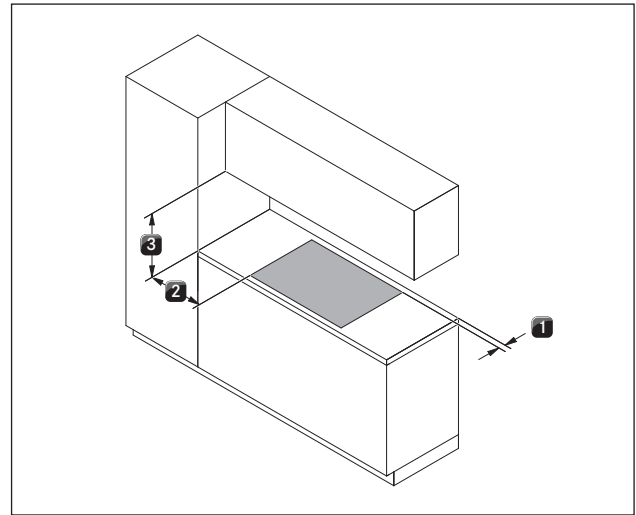

Fig. 5.1 Minimum distance

- [1] Minimum clearance of 50 mm at the back from the worktop cut-out to the rear edge of the worktop.
- [2] Minimum clearance of 300 mm from the left and right of the worktop cut-out to the adjacent cabinet or wall.
- [3] Minimum clearance of 600 mm between the worktop and the wall unit.

5.3.2 Worktop and kitchen units

- ▶ Create the worktop cut-out taking into account the specified cut-out dimensions.
- ▶ Make sure that the cutting surfaces of the worktops are properly sealed.
- ▶ Comply with the instructions of the worktop manufacturer.
- Cross bars on the kitchen unit in the area of the worktop cut-out may need to be removed.
- No false floor is necessary below the cooktop. If cable protection (false floor) is planned, the following must be taken into account:
 - It must be fitted in such a way that it can be removed for maintenance work.
 - To ensure sufficient cooktop ventilation, a minimum distance of 15 mm to the bottom edge of the cooktop is to be observed.
- The drawers and/or shelves in the floor unit must be removable.
- For correct installation, the slide-in units of the base cabinet must be shortened depending on the installation situation.

5.3.3 Recirculation when using the cooktop extractor as a recirculation system

In the case of recirculation systems there must be a return flow aperture in the kitchen units:

- > 500 cm² (per air cleaning box) in combination with cooktops PKFI11, PKI11, PKIW1, PKC32, PKC3B, PKCH2 and PKT11

INFO If several extractor systems are operated in recirculation mode, the return flow aperture for each air cleaning box must be calculated correspondingly.

Example:

2 recirculation systems = 2 x (> 500 cm²)

For recirculation, the necessary return flow aperture can be created using a shortened plinth. A slatted plinth with at least the minimum opening cross-section can also be used.

- Ensure that the return flow aperture is large enough.

5.4 Cut-out dimensions

INFO All dimensions are shown from the front edge of the front cover.

Worktop overhang

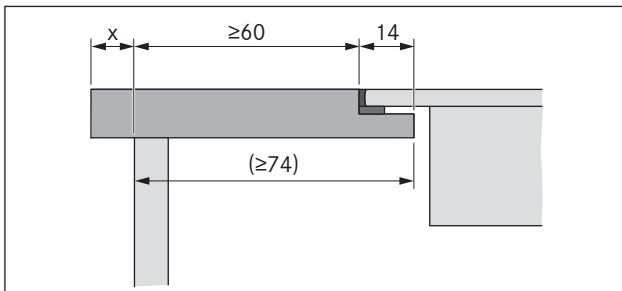

Fig. 5.2 Worktop overhang

- Please note the worktop overhang x when creating the worktop cut-out. Applicable to flush installation and surface mounting.

5.4.1 Flush installation

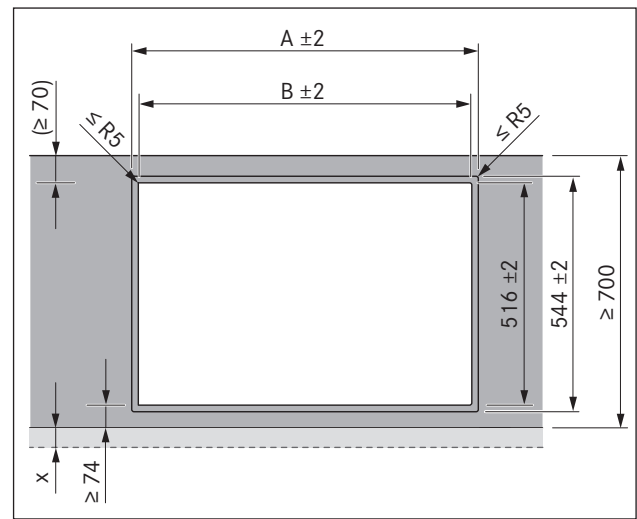

Fig. 5.3 Cut-out dimensions for flush installation

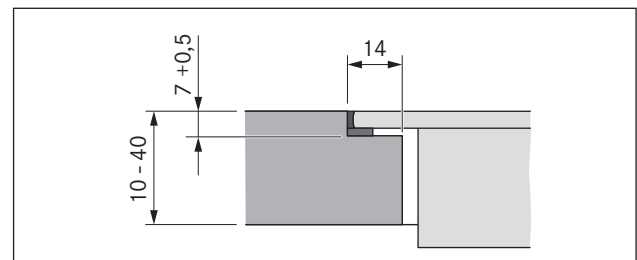







Fig. 5.4 Groove dimensions for flush installation

Cut-out dimensions when installing cooktops or cooktops and the cooktop extractor next to each other:

Cooktops/cooktop extractor	A in mm	B in mm	
	1/0	374	346
	1/1	485	457
	2/1	856	828
	3/2	1338	1310
	4/2	1709	1681

Tab. 5.2 Cut-out dimensions for flush installation of appliance combinations

5.4.2 Surface mounting

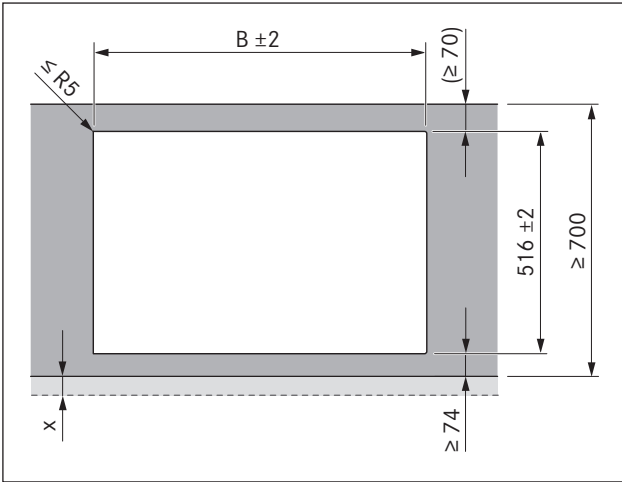

Fig. 5.5 Cut-out dimensions for surface mounting

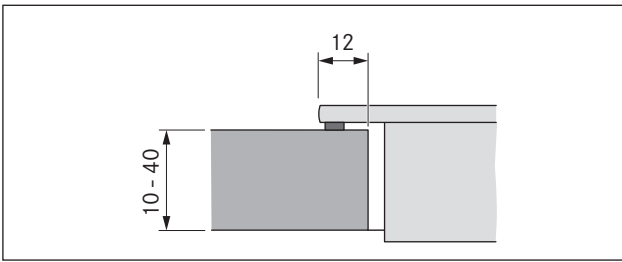

Fig. 5.6 Surface mounting cut-out

Cut-out dimensions when installing cooktops or cooktops and the cooktop extractor next to each other:

Cooktops/cooktop extractor		B in mm
	1/0	346
	1/1	457
	2/1	828
	3/2	1310
	4/2	1681

Tab. 5.3 Cut-out dimensions for surface mounting of appliance combinations

5.5 Installing the cooktop

INFO Clearance of one millimetre should be planned between the built-in appliances.

INFO A clearance of two millimetres should be planned around the built-in appliances.

INFO It is recommended to install a mounting rail between adjacent cooktops (mounting rail PZMS available as an accessory).

INFO Alternatively, the cooktop can be fitted rotated by 180°.

5.5.1 Installing the control knob in the floor unit front panel

INFO Pre-drill the bore holes to prevent tearing out the fixed front panel.

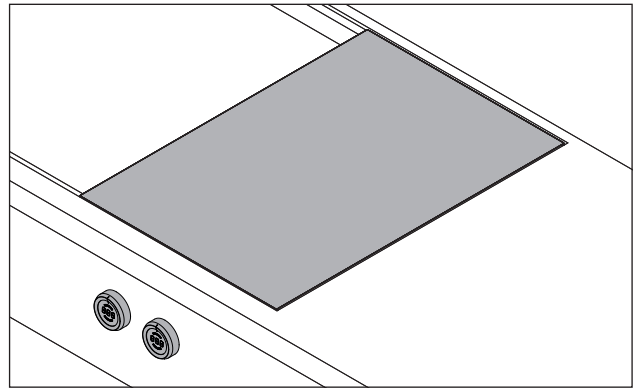

Fig. 5.7 Installed control knob and cooktop

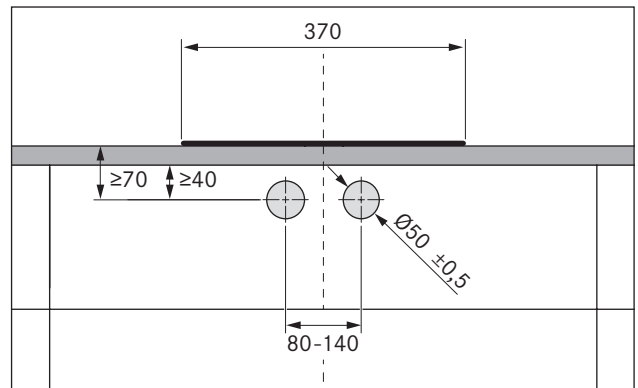

Fig. 5.8 Drill template

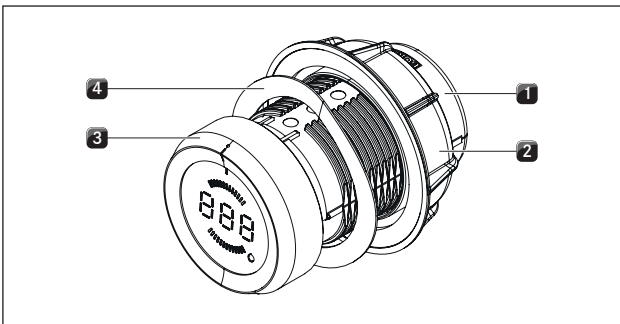

Fig. 5.9 Structure of control knob

- [1] Knob casing
- [2] Universal nut
- [3] knob ring
- [4] Wave spring

INFO The wave spring must not be used with steel fronts. The relevant assembly steps should simply be skipped.

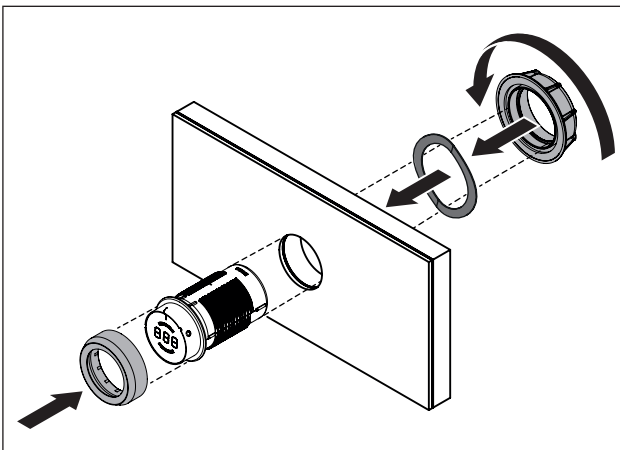

Fig. 5.10 Fitting the control knob

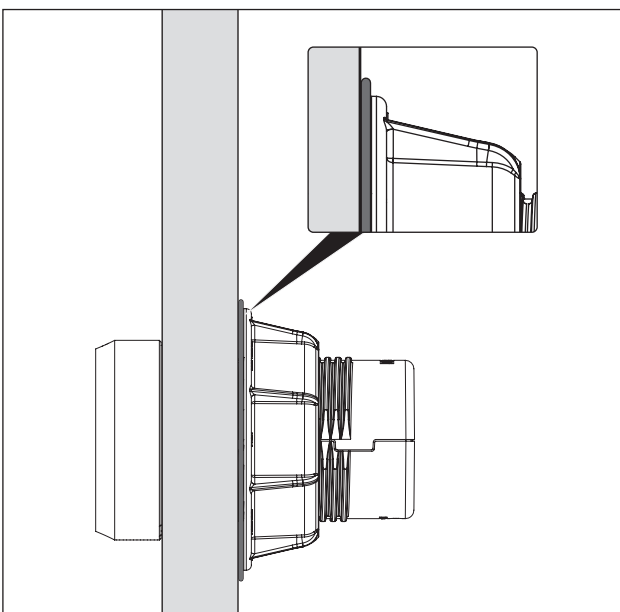

Fig. 5.11 Wave spring once assembly is complete

- ▶ Pull off the knob ring [3].
- ▶ Unscrew the universal nut [2].
- ▶ Pull off the wave spring [4].
- ▶ Push the knob casing [1] through the hole in the panel from the front.
- ▶ Push the wave spring [4] onto the knob casing [1] from the rear (not with steel fronts).
- ▶ Screw the universal nut [2] onto the knob casing [1] from the rear and tighten a little.
- ▶ Use the marking to align the knob casing [1] vertically in the 12 o'clock position.
- ▶ Tighten the universal nut [2].
- ▶ The wave spring (if used) must be pressed flat.
- ▶ Slot the knob ring [3] onto the knob casing [1] and align it to the 12 o'clock position.

Example bore holes

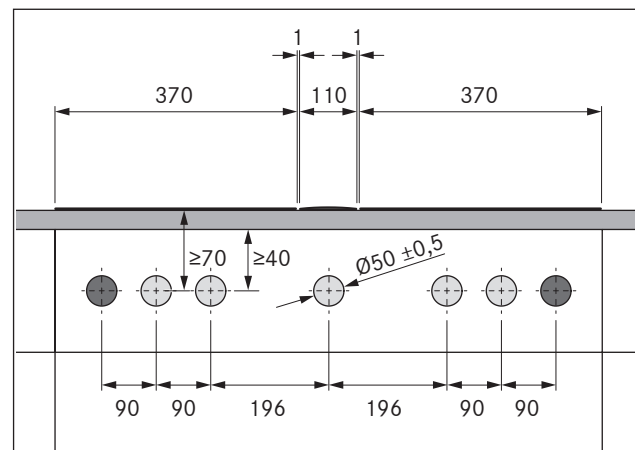

Fig. 5.12 Bore holes for 2 cooktops and 1 cooktop extractor

- [1] Boreholes for socket (2x external)
- [2] Bore holes for control knobs (5x)
- [3] Cooktop (2x)
- [4] Cooktop extractor
- [5] Worktop
- [6] Floor unit front panel

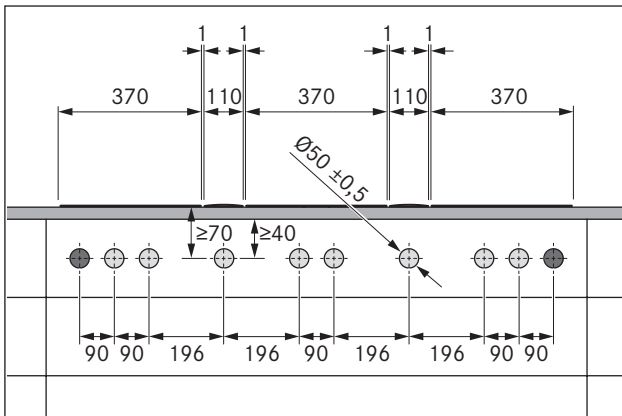

Fig. 5.13 Bore holes for 3 cooktops and 2 cooktop extractors

- [1] Boreholes for socket (2x external)
- [2] Bore holes for control knobs (8x)
- [3] Cooktop (3x)
- [4] Cooktop extractor (2x)
- [5] Worktop
- [6] Floor unit front panel

5.5.2 Installing the cooktop

- ▶ Please note the position of the cooktop display. Alternatively, the cooktop can be fitted rotated by 180° (see Installation rotated by 180°).

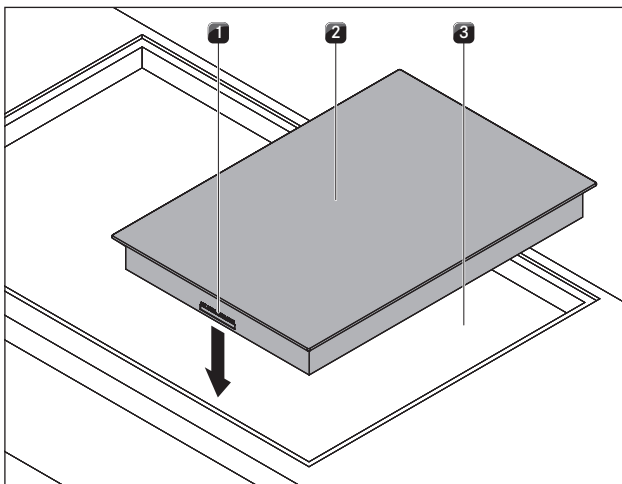

Fig. 5.14 Insert cooktop

- [1] Connections for control knob and automatic extractor function (front)
- [2] Cooktop
- [3] Worktop cut-out

- ▶ Insert the cooktop [2] into the worktop cut-out [3].
- ▶ Align the cooktop [2] exactly.
- ▶ For a normal installation, please note that the connections for the control knobs and the extraction system [1] are at the front.

INFO The device connection should be at the rear. Use the cable holders provided.

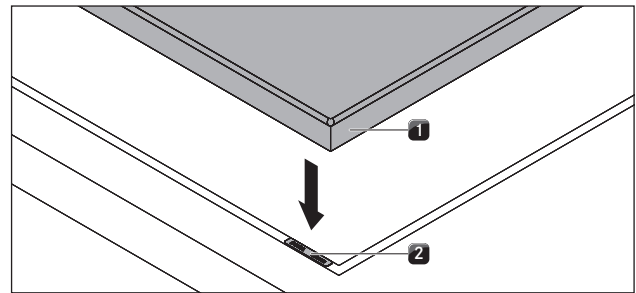

Fig. 5.15 Cooktop and height adjustment plates

- [1] Cooktop
- [2] Height adjustment plates

- ▶ If applicable, insert the height adjustment plates [2].

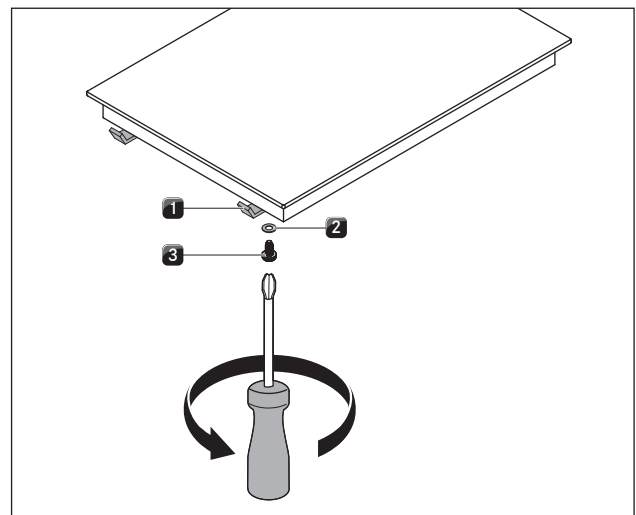

Fig. 5.16 Mounting brackets

- [1] Mounting bracket
- [2] Washer
- [3] Screw

- ▶ Fasten the cooktop using the mounting brackets [1].
- ▶ Tighten the mounting brackets with the screw [3] using the washer [2] with max. 2 Nm.
- ▶ Verify that the alignment is correct..

5.5.3 Installation rotated by 180°

- ▶ Rotate the cooktop 180°.
- ▶ For the installation, proceed as described above.
- ▶ Change the installation direction in the configuration menu (see Configuration menu).

INFO If installation is rotated by 180°, then the connections for the control knobs and the extraction system are at the rear.

INFO If installation is rotated by 180°, the cooktop display is automatically shown as rotated by 180°.

INFO Cables of sufficient length are provided.

5.5.4 Establishing communication

The appliance components are linked by the ribbon cable provided.

- ▶ Create the connection between the cooktop and the control knobs.
- ▶ Create the connection between the cooktop and the cooktop extractor.

Cooking zone connection

INFO According to the default settings, the left control knob operates the front cooking zone and the right control knob operates the rear cooking zone.

Connection on the control knob

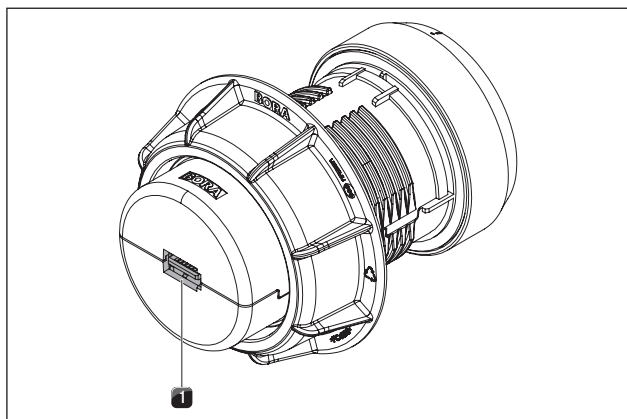

Fig. 5.17 Connection on the rear of the control knob

- [1] Connection on the rear of the control knob

Connections on the cooktop

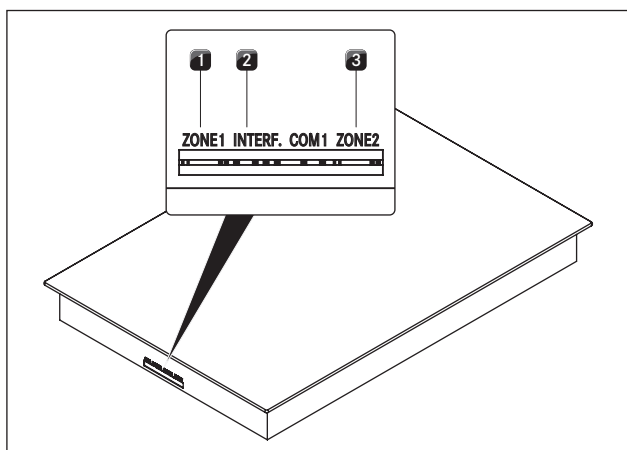

Fig. 5.18 Connections on the cooktop

- [1] Connection of the front cooking zone control knob (zone 1)
- [2] Connection of the automatic extraction system
- [3] Connection of the rear cooking zone control knob (zone 2)

Standard cooking zone connection

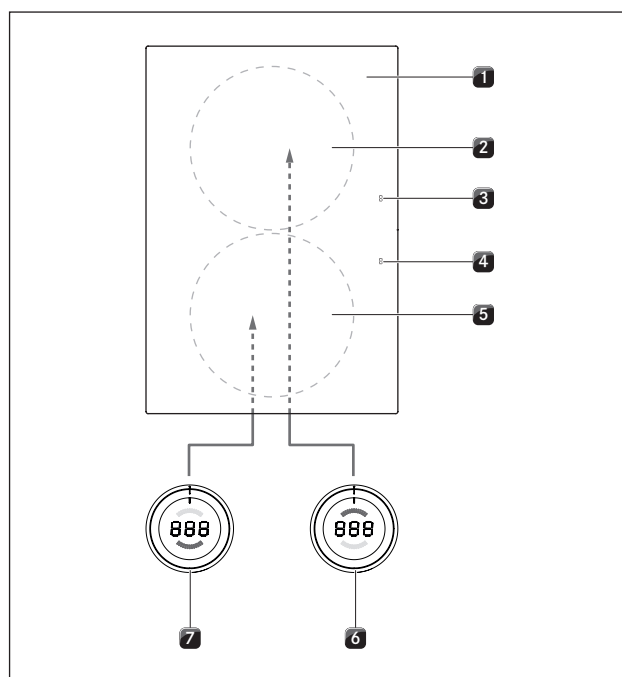

Fig. 5.19 Standard cooking zone connection

- [1] Cooktop
- [2] Rear cooking zone (zone 2)
- [3] Rear cooktop display (zone 2)
- [4] Front cooktop display (zone 1)
- [5] Front cooking zone (zone 1)
- [6] Rear cooking zone control knob (zone 2)
- [7] Front cooking zone control knob (zone 1)

- ▶ Connect the connection on the back of the left control knob [5] to the “zone 1” connection on the front of the cooktop [1].
- ▶ Connect the connection on the back of the right control knob [4] to the “zone 2” connection on the front of the cooktop [1].

Connecting the cooking zones when the cooktop is installed rotated by 180°

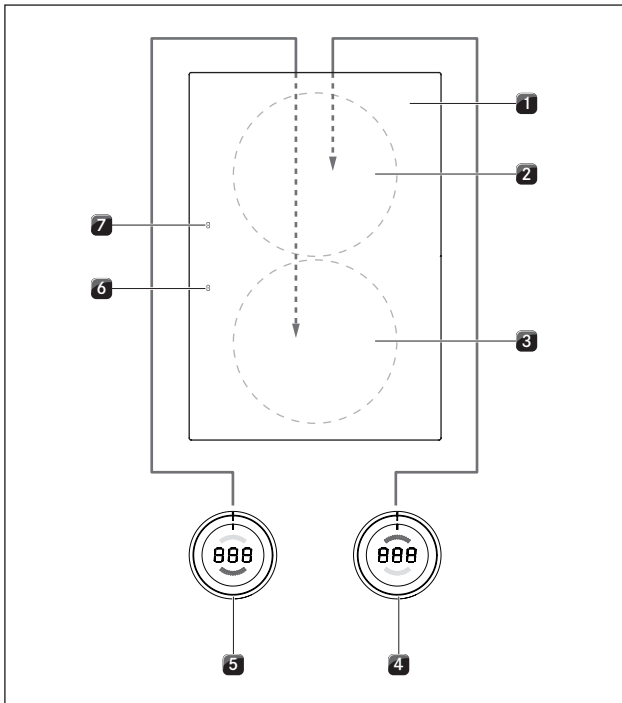

Fig. 5.20 Cooking zone connection in 180° installation

- [1] Cooktop
- [2] Rear cooking zone (zone 1)
- [3] Front cooking zone (zone 2)
- [4] Rear cooking zone control knob (zone 1)
- [5] Front cooking zone control knob (zone 2)
- [6] Front cooktop display (zone 2)
- [7] Rear cooktop display (zone 1)

- ▶ Connect the connection on the back of the left control knob [5] to the “zone 2” connection on the back of the cooktop [1].
- ▶ Connect the connection on the back of the right control knob [4] to the “zone 1” connection on the back of the cooktop [1].
- ▶ Using the configuration menu, set the correct allocation of the cooking zones in the control knob display (see Configuration menu, 0° or 180° installation).

Connecting the automatic extraction system

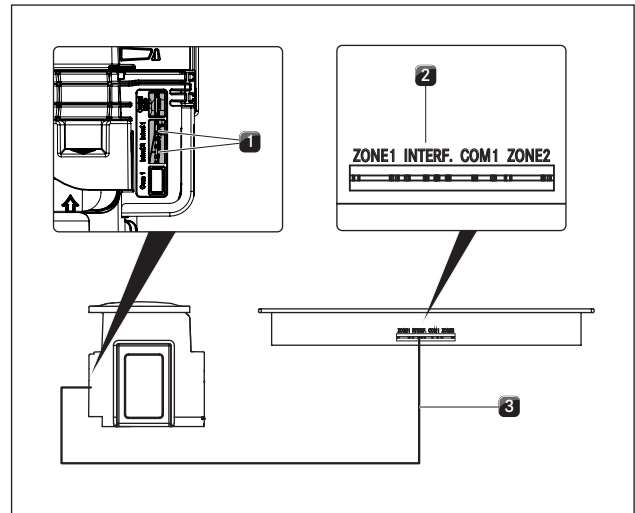

Fig. 5.21 Connection of the automatic extraction system

- [1] Connection of the automatic extraction system (cooktop extractor)
- [2] Connection of the automatic extraction system (cooktop)
- [3] Automatic extraction system cable

- ▶ Connect the cooktop extractor [1] to the cooktop using the connector provided for the automatic extraction system [2].

5.5.5 Establishing the power connection

- ▶ Observe all safety and warning information (see the Safety chapter).
- ▶ Observe all national and regional laws and regulations as well as the supplementary regulations of the local utility companies.

INFO The power connection may only be established by certified specialists. The specialist also assumes responsibility for the proper installation and commissioning.

The power supply line to be used (pre-assembled) must be at least type H05VV-F or H05VVH2-F (see table Fuse protection and minimum cross-section).

Connection	Fuse protection	Minimum cross-section
1-phase connection	1 x 16 A	1.5 mm ²
		2.5 mm ² in Australia and New Zealand (AUS/NZS)

Tab. 5.4 Fuse protection and minimum cross-section

- If the connection cable has been damaged this must be replaced. This may only be done by an authorised member of the After Sales Service team.

- ▶ Switch off the main switch/automatic circuit breaker before connecting the cooktop.
- ▶ Secure the main switch/automatic circuit breaker against being switched back on without permission.
- ▶ Make sure the power to the appliance is disconnected.
- ▶ Only connect the cooktop using a permanent connection to a power supply cable.

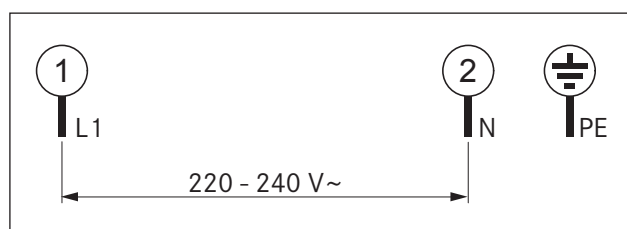

Fig. 5.22 Connection diagram 1-phase

- ▶ Check that installation has been carried out correctly.
- ▶ Switch on the main switch/automatic circuit breaker.
- ▶ Put the cooktop into operation (see the Operation chapter).
- ▶ Check that all the functions are working correctly.

5.6 Configuration menu

Once installation is complete, you can adjust the basic settings for the cooktop. These can then be changed at any time.

5.6.1 Accessing the configuration menu

- ▶ Turn the control knob to the 11 o'clock position. The control knob display shows \bar{E} .
- ▶ Press the touch surface of the control knob for one second. The display changes to 000.
- ▶ Press the touch surface again within 3 seconds and hold for 5 seconds.
- The control knob display shows \bar{C} , a beep is heard and the configuration menu is available.

5.6.2 Select menu option

- ▶ Turn the knob ring to select the menu option you want. The following menu options are available:

Menu options	
$\bar{C}0$	Warning beep volume
$\bar{C}1$	Select operating mode (normal operation or demo mode)
$\bar{C}2$	0° or 180° installation
$\bar{C}9$	Availability of the pause function

Tab. 5.5 Menu options in the configuration menu

- ▶ Touch the touch surface on the control knob again for 1 second to confirm the menu you want.
- The sub-menu is accessed and the display switches to a three-character combination (e.g. $\bar{C}23$).

INFO In the three-character combination shown, the right-hand figure shows the value saved in the system.

Setting the volume of the warning beep

Once you have confirmed menu option $\bar{C}0$, you can set the volume of the warning beep.

Setting	Warning beep volume	
$\bar{C}00$	100% (max. volume)	Factory setting
$\bar{C}01$	10% (min. volume)	
$\bar{C}02$	20%	
$\bar{C}03$	30%	
$\bar{C}04$	40%	
$\bar{C}05$	50%	
$\bar{C}06$	60%	
$\bar{C}07$	70%	
$\bar{C}08$	80%	
$\bar{C}09$	90%	

Tab. 5.6 Warning beep volume

Select operating mode

Once you have confirmed menu option $\bar{C}1$, you can select the operating mode.

Setting	Operating mode	
$\bar{C}10$	Normal operation	Factory setting
$\bar{C}11$	Demo mode	

Tab. 5.7 Operating modes

INFO All the control knob functions are available in demo mode. The heating function for the cooktop is deactivated. Demo mode is used, for example, for exhibitions.

0° or 180° installation

In menu option $\bar{C}2$, you can set whether the cooktop is installed rotated by 180°.

Setting	Display	
$\bar{C}20$	0° installation	Factory setting
$\bar{C}21$	180° installation	

Tab. 5.8 Installation direction

INFO For installation rotated by 180°, the setting $\bar{C}21$ correctly assigns the correct cooking zones inside the control knob display and the cooktop display is shown rotated by 180°.

Availability of the pause function

Once you have confirmed menu option C9 , you can permanently deactivate the pause function.

Setting	Pause function available/deactivated
C90	Pause function activated Factory setting
C91	Pause function deactivated
C92	Pause function with power level display activated

Tab. 5.9 Availability of the pause function

5.6.3 Changing the set value

- ▶ Turn the knob clockwise to increase the value.
- ▶ Turn the knob ring anti-clockwise to reduce the value.
- ▶ Press the touch surface on the control knob for 1 second to confirm the new value. The value is saved and a beep is heard. The previously selected menu option is shown in the control knob display.

5.6.4 Exiting the configuration menu

- ▶ Twist the knob ring until the display shows C .
- ▶ Now press the touch surface on the control knob again for 1 second to exit the configuration menu. The display goes out and a beep sounds.
- ▶ Turn the knob ring to the 12 o'clock position. 0 appears in the display for 10 seconds. The display then goes out with a beep.

INFO If no settings are changed in a menu or submenu option for 2 minutes, the configuration menu is closed automatically.

- ▶ Once all of the installation work and initial operation is complete, seal the devices all around with black, heat-resistant silicone sealant (also between the cooktop extractor and cooktop) [1].
- ▶ Make sure that no silicone sealant gets under the cooktop.

5.8 Handover to user

Once installation is complete:

- ▶ Explain the main functions to the user.
- ▶ Explain all safety-related aspects of operation and handling to the user.
- ▶ Adhere the supplied nameplate to the back of these operating and installation instructions.
- ▶ Provide the user with the accessories and operating and installation instructions to be kept in a safe place.

5.7 Sealing the devices

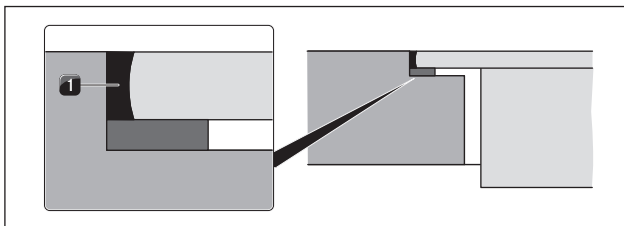

Fig. 5.23 Silicone sealant for flush installation

[1] black, heat-resistant silicone sealant

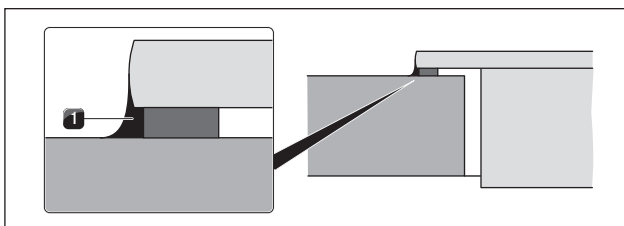

Fig. 5.24 Silicone sealant for surface mounting

[1] black, heat-resistant silicone sealant

6 Operation

- Observe all safety and warning information during operation (see the Safety section).

INFO The cooktop may only be operated when the stainless steel grease filter of the cooktop extractor is installed (see operating instructions for cooktop extractor).

INFO Clean the cooking zone before using the cooktop for the first time (see the Cleaning section).

6.1 General operating instructions

The cooktop is controlled using the control knobs. Each cooking zone has its own control knob. The front cooking zone is controlled using the left-hand knob and the back cooking zone with the right-hand knob. There are 9 power levels, one power setting and various functions available for each cooking zone.

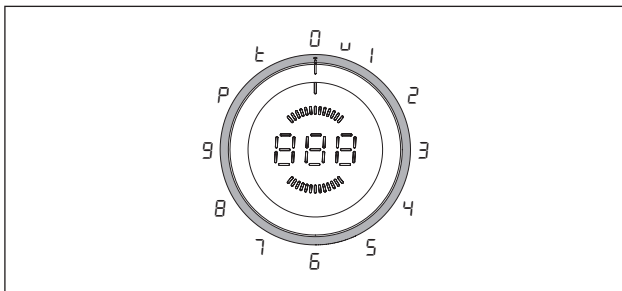

Fig. 6.1 Knob ring assignment

Knob ring position	Function
□	Switching off
u	Heat retention level
1 - 9	Power levels
P	Power setting
t	Timer function

Tab. 6.1 Knob ring positions

6.2 Operating the cooktop

6.2.1 Switching on the cooking zone

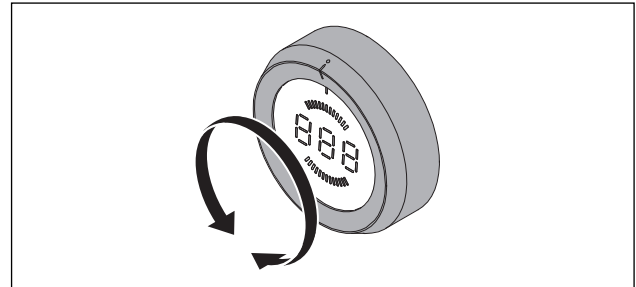

Fig. 6.2 Switching on the cooking zone

- Turn the knob ring from the 12 o'clock position to a power level.

Adjusting the power level

- Turn the knob ring to the desired power level.
- The selected power level is activated and displayed.

6.2.2 Power setting

Switching on the power setting

INFO Both cooking zones are equipped with a power-enhancing power setting.

INFO The power setting cannot be activated if the bridging function is switched on.

If a cooking zone is operated at power setting P , the other cooking zones can be operated at a maximum power level of 5.

If the power setting is increased from 5, the power level is switched down from P .

If the power level is set higher than 5 when power setting P is activated for the other cooking zone, it is automatically reduced to power level 5 after 3 seconds (the control knob display flashes for 3 seconds).

If the power setting P is deactivated again within these 3 seconds, the second cooking zone can continue to be operated at the higher power level.

- Twist the knob ring to the 10 o'clock position.
- P is displayed and the power level is activated.
- After 10 minutes, the cooking zone is automatically switched back to power level 9.

Switching the power setting off early

- Turn the knob ring to the desired power level.
- The power level set is active and is displayed.

6.2.3 Bridging function

INFO If the bridging function is active, both cooking zones will operate at the same time on the same cooking zone.

INFO If the bridging function is activated, the power setting P cannot be used.

Switching on the bridging function

Both control knobs are in the 12 o'clock position.

- ▶ Press the touch surface on both control knobs at the same time for at least 1 second.
- The left control knob display and the front cooking zone indicator show \overline{P} .
- The right control knob display and the rear cooking zone indicator show \overline{P} .
- ▶ Within 3 seconds, twist the knob ring on the right hand control knob to the power level you want.
- The right-hand control knob can now be used to control the power levels for both cooking zones.
- The power level indicator for both cooking zones can be seen in the display of the right control knob and in the rear cooking zone indicator.
- If the right-hand control knob is not twisted to a power level within 3 seconds of the bridging function being activated, the bridging function is deactivated and the cooktop is switched off.

Switching off bridging function

- ▶ Twist the right-hand control knob to the 12 o'clock position.
- The bridging function and the cooktop are now switched off.

6.2.4 Automatic heat up function

Switching on the automatic heat up function

INFO The exact values for the heat-up time can be found in the Device description section.

- ▶ Select the desired power level (= later continuous cooking level).
- ▶ Within 3 seconds of setting the power level, press the touch surface of the control knob for at least 1 second.
- The automatic heat up function is activated and the control knob shows an A in front of the continuous cooking level selected (e.g. $A3$).

INFO When the automatic heat up function is active, A is displayed.

- Once the automatic heat up period has passed, the power is reduced to the selected continuous cooking level.
- If a higher continuous cooking level is selected while the automatic heat up function is active, the new heat-up time is automatically valid.

6.2.5 Switching off the automatic heat up function

The activated automatic heat up function will end prematurely if you

- ▶ reduce the power level (continuous cooking level).
- ▶ set power level G .
- ▶ activate power setting P .
- ▶ activate heat retention level \cup .
- ▶ switch off the cooktop.

6.2.6 Heat retention level

Activating the heat retention level

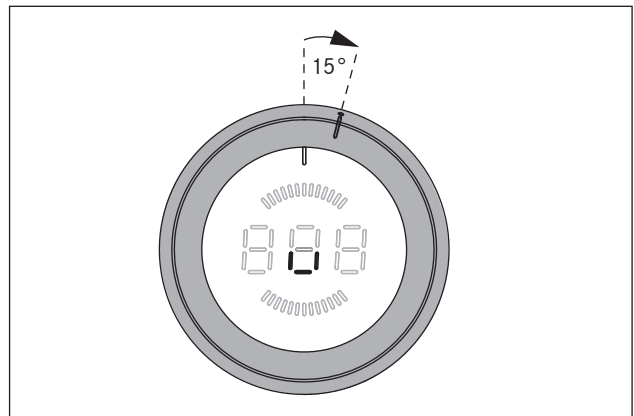

Fig. 6.3 Knob ring setting for heat retention level

INFO The knob ring position for the heat retention level is between the 12 o'clock position and the 1 o'clock position.

- ▶ Turn the selector ring approximately 15° clockwise from the 12 o'clock position until it lightly engages.
- \cup appears in the control knob display.
- ▶ Press the touch surface on the control knob for 1 second to activate the heat retention level 1.
- This is confirmed with an acoustic signal and the symbol \cup is displayed.

Heat retention level	1	2	3
Symbol	\cup	\cup	\cup
Temperature in °C	42	74	94

Tab. 6.2 Temperatures of heat retention levels

Increase heat retention level

- ▶ Press the touch surface on the control knob a second time for 1 second to activate heat retention level 2 (±).
- ▶ Press the touch surface on the control knob a third time for 1 second to activate heat retention level 3 (±).
- This is always confirmed with an acoustic signal and the corresponding symbol is displayed.

Reduce heat retention level

- After setting heat retention level 3, pressing the touch surface (1 second) again reduces the level by 1.
- This is always confirmed with an acoustic signal and the corresponding symbol is displayed.

Switching off heat retention level

The heat retention level activated switches off if you

- ▶ select another power level
- ▶ switch off the cooking zone

6.2.7 Childproofing feature

INFO The childproofing feature can only be activated or permanently deactivated if both knob rings are at the 12 o'clock position and no function is active.

Activating the childproofing feature

- ▶ Press the touch surface of one of the control knob for 5 seconds.
- An acoustic signal is heard and L is displayed. The display goes blank after 10 seconds and the childproofing feature is activated.

Permanently deactivating the childproofing feature

- ▶ Press the touch surface of one of the control knob for 5 seconds.
- An acoustic signal is heard and the display changes to □. The display goes blank after 10 seconds and the childproofing feature is permanently deactivated.

Deactivating the childproofing feature for a cooking session

- ▶ Turn the knob ring from the 12 o'clock position to a power level.
- L is displayed.
- ▶ Press the touch surface of the control knob for 5 seconds.
- An acoustic signal is heard and the selected power level is displayed.
- The childproofing feature is only deactivated for this cooking session and you can set the power level you want.
- The childproofing feature is reactivated next time you switch on.

INFO If the cooktop is switched off at the end of the cooking session (turn the selector ring to the 12 o'clock position), the childproofing feature is automatically re-activated.

6.2.8 Using the timer function

INFO You can set a time range of between 1 and 120 minutes for the timer functions.

Set time

- ▶ Twist the knob ring to the 11 o'clock position.
- L appears on the control knob display.
- ▶ Press the touch surface for one second.
- A beep can be heard and the control knob display switches to □□□.
- ▶ Within 3 seconds, twist the knob ring to set the timer time.
- Turning clockwise increases the time (starting at 0 minutes), while turning anticlockwise reduces the time (starting at 120 minutes).
- In the range from 0 to 20 minutes, the time reduces/ increases in both directions by one minute at a time, while the increments are 5 minutes for the rest of the range.
- If no time is set within 3 seconds, the timer is deactivated and the control knob display switches to L.
- ▶ Press the touch-surface within 3 seconds to confirm the time set.
- A beep sounds and the set value starts to flash on the control knob display.

Activating the timer function

- ▶ Once you have confirmed the time set, you have 3 seconds to turn the knob ring to the power level you want.
- This activates the timer function and the time starts to count down.
- The displays swaps (for 3 seconds each) between the power level and the remaining time (accurate to the minute for more than 2 minutes and accurate to the second for under 2 minutes).
- Once the remaining time is less than 2 minutes, only the time is displayed.
- At the end of the time, the cooking zone is switched off, a beep sounds for 2 minutes and the control knob display flashes □□□.
- The flashing and the beeping can be stopped by pressing the touch area or twisting the knob ring to the 12 o'clock position.

Switching the timer off early:

- ▶ Twist the knob ring to the 12 o'clock position.
- The control knob display changes to 0, a beep sounds and the cooking zone switches off.

Activating the short-time timer (egg timer)

- ▶ Once you have confirmed the time set, you have 3 seconds to turn the knob ring to the 12 o'clock position.
- This activates the short-time timer and the time starts to count down.
- The displays shows remaining time (accurate to the minute for more than 2 minutes and accurate to the second for under 2 minutes).
- At the end of the time, a beep sounds for 2 minutes and the control knob display flashes 000.
- The flashing and the beeping can be stopped by pressing the touch surface.

Switching off the short-time timer (egg timer) early:

- ▶ Press the touch surface of the knob ring.
- The short-time timer is deactivated.
- The control knob display shows 0 and a beep sounds.

- ▶ Twist the knob ring to the 12 o'clock position.
- A beep sounds and the cooking zone is deactivated.
- The cooktop is switched off when there are no longer any active cooking zones.
- ▶ Pay attention to the residual heat display (see the Device Description section).

6.2.9 Pause function

Activate pause function

- ▶ Press the touch surface of the control knob for 1 second.
- A signal tone is heard and H is displayed.
- The cooking session is interrupted.

INFO The cooking session can be paused for a maximum of 10 minutes. If the pause function is not deactivated in this time, the relevant cooking zone is switched off.

Deactivate pause function

- ▶ Press the touch surface of the control knob for 1 second.
- A signal tone is heard and the previously set power level is displayed.
- The cooking session continues.

6.2.10 Switching off the cooking zone

INFO When H is displayed, the cooking zone is still hot.

INFO Turn the cooking zone off after use. Do not rely on the pan size recognition.

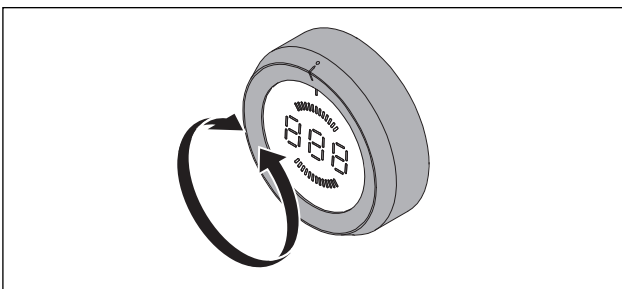

Fig. 6.4 Switching off the cooking zone

7 Cleaning and Maintenance

- ▶ Observe all safety and warning information (see the Safety chapter).
- ▶ Follow the enclosed manufacturer's information.
- ▶ When conducting scheduled cleaning and maintenance, ensure that the cooktop and cooktop extractor are fully switched off and cooled so as to prevent injury (see the Operation chapter).
- Regular cleaning and maintenance ensures long service life of the product and optimal function.
- ▶ Adhere to the following cleaning and maintenance cycles:

Component	Cleaning cycle
Control knob	immediately after soiling with conventional detergents
Cooktop	

Tab. 7.1 Cleaning cycles

7.1 Cleaning agents

INFO Due to the use of aggressive cleaning agents and abrasion caused by the pot bases the surface will become damaged and dark stains will occur.

To clean the cooktop, you need a special glass ceramic scraper and suitable cleaning agents.

- ▶ Never use steam cleaners, abrasive sponges, scouring pads or chemically aggressive cleaning agents (e.g. oven cleaner spray).
- ▶ Make sure that the cleaning agent does not contain any sand, soda, acids, lyes or chloride.

7.2 Looking after the cooktop

- ▶ Never use the cooktop as a work or storage surface.
- ▶ Do not push or pull cookware over the cooktop.
- ▶ Always lift pots and pans.
- ▶ Keep the cooktop clean.
- ▶ Remove any dirt immediately.
- ▶ Only use cookware suitable for glass ceramic cooktops (see Appliance description chapter).

7.3 Cleaning the cooktop

- ▶ Make sure that the cooktop is switched off (see the Operation chapter).
- ▶ Wait until all cooking zones are cold.
- ▶ Remove all coarse dirt and food residues from the cooktop using a glass ceramic scraper.
- ▶ Apply the cleaning agent to the cold cooktop.
- ▶ Spread the cleaning agent using kitchen roll or a clean cloth.
- ▶ Wipe the cooktop clean with a damp cloth.
- ▶ Dry the cooktop with a clean cloth.

If the cooktop is hot:

- ▶ Remove stubborn residues of plastic, aluminium foil, sugar or sweet dishes from the hot cooking zone immediately using a glass ceramic scraper to prevent burning.

Heavy soiling

- ▶ Remove heavy soiling and marks (limescale marks, mother-of-pearl-like shiny marks) using cleaning products while the cooktop is still warm.
- ▶ Wipe off food that boils over with a damp cloth.
- ▶ Remove any remaining dirt with the glass ceramic scraper.
- ▶ Always remove any seeds, crumbs or similar that fall onto the cooktop during cooking immediately to prevent the surface getting scratched.

Any changes in colour or glossy spots are not damage to the cooktops. They do not affect the functionality of the cooktop or the stability of the glass ceramic panel. Changes in the colour of the cooktop are the result of residues which have not been removed and have burnt on.

Glossy spots are the result of wear by the pan base, especially if aluminium-based cookware or unsuitable cleaning agents are used. These are difficult to remove.

7.4 Cleaning the control knobs

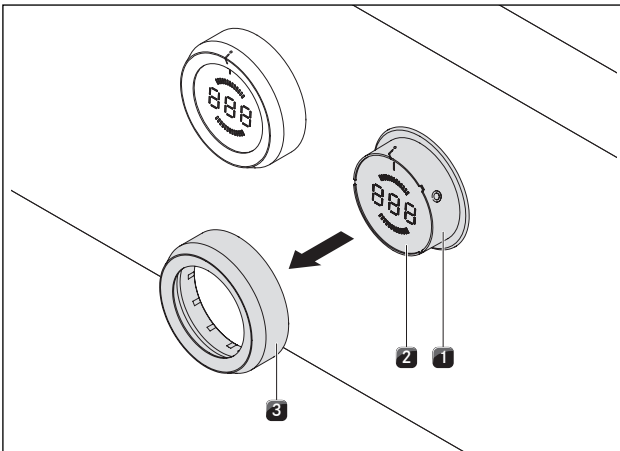

Fig. 7.5 Pull out the knob ring

- [1] Knob casing
- [2] Touch surface
- [3] Knob ring

7.4.1 Cleaning the knob ring

The knob ring can only be cleaned by hand.

- ▶ Remove the knob ring from the knob housing.
- ▶ Use a cleaner and degreaser in one.
- ▶ Rinse the knob ring with hot water.
- ▶ Clean the knob ring with a soft brush.
- ▶ Rinse the knob ring well after cleaning.
- ▶ Dry the knob ring carefully.
- ▶ Place the dry knob ring back on the knob housing.
- ▶ Make sure it is positioned correctly (0 position).
- ▶ If necessary, turn the knob ring to the 12 o'clock position (= 0 position).



7.4.2 Cleaning the touch surface and the knob housing

- ▶ Remove the knob ring.
- ▶ Clean the touch surface and the knob housing with a soft, damp cloth.
- ▶ Dry the touch surface and the knob housing carefully.
- ▶ Place the knob ring back on the knob housing.

INFO If the knob ring has not been fitted correctly, a segment rotating clockwise is displayed in the central control knob display (🌀).

8 Troubleshooting

Observe all safety and warning information (see the Safety section).

Operating situation	Cause	Remedy
The cooktop cannot be switched on.	Knob ring missing	Place the knob ring on the control knob.
	The fuse or automatic circuit breaker of the electrical wiring system in the apartment and/or house is defective.	Replace the fuse. Switch the automatic circuit breaker back on
	The fuse or the automatic circuit breaker trips multiple times	Contact BORA Service Team
	The power supply is disconnected.	Have a specialist electrician inspect the power supply
Formation of odours and vapours when operating the new cooktop	Normal for brand new devices	Wait a few hours If the odours continue to develop, contact the BORA Service Team
The cooling fan continues running after switching off	The cooling fan will continue to run until the cooktop has cooled down and will then switch off automatically.	Wait until the cooling fan switches off automatically.
A cooking zone or the entire cooktop switches off automatically.	Cooking zone operating for too long	Put the cooking zone back into operation (see the Operation section).
	The overheating protection has tripped	(see the Device Description section)
The power setting has automatically shut off too early.	The overheating protection has tripped	(see the Device Description section)
the central control knob display shows a segment turning clockwise 	Knob ring not in the 0 position after fitting	Turn the control knob to the 12 o'clock position (= 0 position),
Control knob display 	The childproofing feature is activated	Switch off the childproofing feature (see the Operation section).
Control knob display 	No or unsuitable cookware on the cooking zone	Only use suitable cookware Select the cookware size depending on the cooking zone (see the Device Description section)
Control knob display 	Continuous operation (30 s) of the control knob or control knob dirty	Release or clean the control knob
Control knob display 	Electrical connection between touch surface and knob ring (min. 3-5 seconds)	Remove the knob ring and wipe residual water from the touch surface
Control knob display 	Error evaluating the touch surface	Twist control knob to "0" position Call BORA Service Team
Control knob display 	Temperature too high	Allow cooktop to cool

Tab. 8.1 Resolving a fault

- ▶ After troubleshooting, turn the knob ring to the 12 o'clock position (0 position).
- ▶ In all other cases, contact the BORA Service Team (see section 'Warranty, technical service and spare parts) and enter the error number displayed and the device type.

9 Decommissioning, disassembly and disposal

- ▶ Observe all safety and warning information (see the Safety section).
- ▶ Follow the enclosed manufacturer's information.

9.1 Decommissioning

Decommissioning is understood as final shutdown and disassembly. Following decommissioning, the device can either be installed into other units, sold on privately or disposed of.

INFO Electricity and gas connections may only be disconnected by qualified specialists.

- ▶ To decommission, switch the device off (see Operation section)
- ▶ Disconnect the device from the power supply.

9.2 Disassembly

For removal, the device must be accessible for disassembly and disconnected from the power supply.

- ▶ Undo the mounting brackets.
- ▶ Remove the silicone joints.
- ▶ Remove the device from the worktop by lifting it upwards.
- ▶ Remove any other accessories.
- ▶ Dispose of the old device and any contaminated accessories as described under "Environmentally-friendly disposal".

9.3 Environmentally-friendly disposal

Disposal of transport packaging

INFO The packaging protects the device from damage in transport. The packaging materials have been selected from environmental and disposal perspectives and are therefore recyclable.

Returning the packaging to the materials cycle saves resources and reduces waste volumes. Your specialist supplier will take the packaging back.

- ▶ Give the packaging to your specialist supplier or
- ▶ Dispose of the packaging properly in line with local regulations.

Disposal of old appliance



Electrical devices marked with this label may not be disposed of in domestic waste at the end of their service life. They must be disposed of at a collection point for the recycling of old electrical or electronic devices. You can find information from your city or district council.

Many electrical and electronic devices still contain valuable materials. But they also contain damaging materials which were necessary for them to function properly and safely. These can damage human health or the environment if disposed of improperly or incorrectly handled.

- ▶ Never put your old appliance in domestic waste.
- ▶ Take the old appliance to a regional collection point for return and recycling electrical and electronic components and other materials.

10 Warranty, technical service, spare parts, accessories

- Observe all safety and warning information (see the Safety chapter).

10.1 BORA manufacturer's warranty

BORA provides its end customers with a 2-year manufacturer's warranty for its products. The end customer is entitled to this warranty in addition to the statutory claims for defects against the sellers of our products.

The manufacturer's warranty applies to all BORA products sold by authorised BORA dealers with the European Union, with the exception of products labelled by BORA as Universal products or accessories.

The manufacturer's warranty starts as soon as the BORA product is handed over to the end customer by an authorised BORA dealer and is valid for 2 years. By registering on www.bora.com/registration the end customer has the possibility of extending the manufacturer's warranty.

The manufacturer's warranty requires expert (in accordance with the valid BORA ventilation handbook and operating instructions at the time of installation) installation of the BORA products by an authorised BORA dealer. During use, the end customer is to adhere to the specifications and instructions in the operating manual. In order to file a warranty claim, the end customer is to notify their dealer or BORA of the fault and must present the receipt. Alternatively, the end customer can provide proof of purchase by registering on www.bora.com. BORA guarantees that all BORA products are free from material and product defects. The defect must exist prior to delivery of the product to the end customer. In the event that a warranty claim is filed, the warranty shall not commence anew.

BORA will correct defects in BORA products at its own discretion by repairing or replacing the product. All costs for the correction of defects under the manufacturer's warranty shall be assumed by BORA.

Expressly not covered by the BORA manufacturer's warranty are:

- BORA products that were not sold by authorised BORA dealers
- Damage caused by non-adherence to the operating instructions (including product care and cleaning) This represents improper use.
- Damage caused by normal use, e.g. traces of usage on the cooktop

- Damage caused by external influences (such as transport damage, ingress of condensation, damage caused by the elements such as a lightning strike)
- Damage caused by repairs or attempts to repair not made by BORA or persons authorised by BORA
- Damage to the glass ceramic
- Voltage fluctuations
- Secondary damage or claims for damages beyond the defect
- Damage to plastic parts

Legal claims, particularly statutory claims for defects or product liability are not limited by the warranty.

If a defect is not covered by the manufacturer's warranty, the end customer can employ the services of the BORA technical service, however, they must cover the costs themselves.

The laws of the Federal Republic of Germany apply to these warranty conditions.

You can contact us by:

- Telephone: +49 800 7890 0987 Monday to Thursday from 08:00-18:00 and Friday from 08:00-17:00
- Email: info@bora.com

10.2 Service

BORA Service:

see reverse side of operating and assembly instructions



- In the case of faults you cannot fix yourself, contact your BORA specialist supplier or the BORA Service Team.

The BORA Service Team will require the type designation and serial number of your device (FD number).

Both pieces of information can be found on the nameplate on the back of the instructions and on the appliance base.

10.3 Spare parts

- Only use original spare parts for repairs.
- Repairs may only be carried out by the BORA Service Team.

INFO Spare parts can be obtained from your BORA dealer, the BORA online service website at www.bora.com/service or by calling the service number provided.

10.4 Accessories

- BORA Glass ceramic scraper UGS

11 Notes

Nameplate:
(please affix)

Germany:

BORA Lüftungstechnik GmbH
Rosenheimer Str. 33
83064 Raubling
Germany
T +49 (0) 8035 / 9840-0
F +49 (0) 8035 / 9840-300
info@bora.com
www.bora.com

Austria:

BORA Vertriebs GmbH & Co KG
Innstraße 1
6342 Niederndorf
Austria
T +43 (0) 5373 / 62250-0
F +43 (0) 5373 / 62250-90
mail@bora.com
www.bora.com

Europe:

BORA Holding GmbH
Innstraße 1
6342 Niederndorf
Austria
T +43 (0) 5373 / 62250-0
F +43 (0) 5373 / 62250-90
mail@bora.com
www.bora.com

Australia - New Zealand:

BORA APAC Pty Ltd
100 Victoria Road
Drummoyne NSW 2047
Australia
T +61 2 9719 2350
F +61 2 8076 3514
info@boraapac.com.au
www.bora-australia.com.au

