

Hardwood Table with Adjustable Undershef

ASSEMBLY INSTRUCTIONS

CAUTION

INSPECT CONTENTS IMMEDIATELY AND FILE CLAIM WITH DELIVERING CARRIER FOR ANY DAMAGE.
SAVE YOUR BOX AND ALL PACKING MATERIALS.
YOU ARE RESPONSIBLE FOR DAMAGE TO YOUR UNIT IF RETURNED IMPROPERLY PACKED.

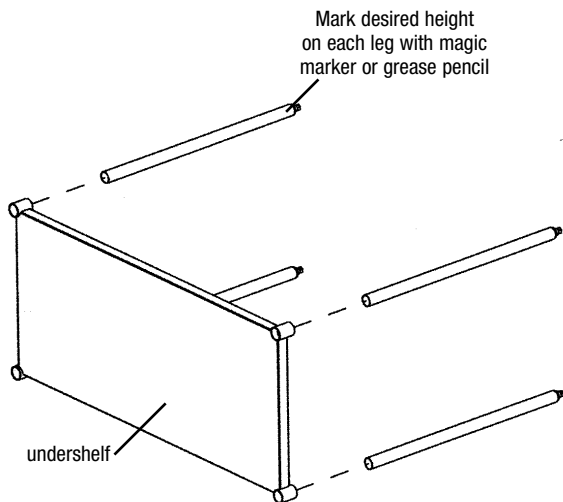

figure 1

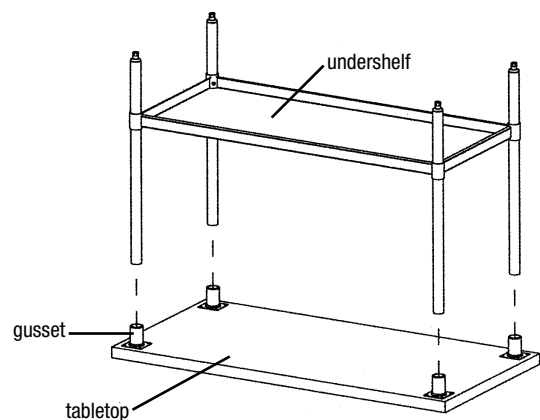

figure 2

Step 1 - Assemble legs to undershef at desired height*.

Secure legs to undershef with set screws**, using 5/32" allen wrench. Each leg must be at the same height or shelf collars could fail. See *figure 1*.

Note: Undershef must be level. Use care not to overtighten undershef set screws** or failure will occur.

Step 2 - Assemble legs to tabletop.

- Place tabletop on floor upside-down, preferably on a smooth padded surface to reduce the possibility of scratching the tabletop.
- Insert legs into gussets as shown in *figure 2*, and secure legs to gusset with allen set screws** provided.

Step 3 - Set table upright.

After legs and undershef are secured, set table in upright position.

* Recommended height from the floor to the top of undershef is 10".

** To meet NSF standards:

Set screws must be filled
with NSF-approved sealant.



NSF-approved sealant.

(End)

ADJUSTING UNDERSHEF AFTER ASSEMBLY:

- To adjust height of undershef, loosen all set screws and retighten after adjustment.
- Make sure undershef is level.
- Use care when moving table. Do not drag table across floor as this may cause damage to the undershef corners.

FOR CLEANING:

1. Wooden cutting boards, butchers blocks, and bakers tables are not intended to be soaked for a prolonged length of time during the cleaning and sanitizing process.
2. Wipe down wood surfaces with warm, soapy water. The top or cutting board should be dried with a rag to insure no standing water remains. Most household cleaners like Windex® or Formula 409® can also be used to clean the top or cutting board*.
3. Stains can usually be removed with fingernail polish remover or chlorine bleach without damage to the wood surface.
4. The Urethane finish is an exceptionally durable finish. However, NO finish is waterproof. If the wood surface is to be kept immaculate, treat it like a piece of furniture.
5. In most cases, the finish will last for years without further treatment. However, over time, the finish will degrade with continuous use and cutting directly on the surface. If desired, the surface can be sanded down and refinished. We recommend Emmet's "Good Stuff" gel urethane wood finish.

* Exceptions: Do not use ammonia-based products as they can cloud the finish. Abrasive cleaners and scouring pads can scratch the top.

EG9982 Revised 02/23