

omega
altise

OAPC147

PORTABLE AIR CONDITIONER



Table of Contents

Table of Contents.....	2
Important Safeguards	3-4
Placement and Installation.....	5-6
Parts List.....	6-7
Control Panel	8
Remote Control.....	9
Operation Methods	9-10
Water Drainage.....	11
Maintenance	11-12
Troubleshooting.....	13
Technical Data.....	14
Circuit Diagram	Appendix A

Important Safeguards

Please read this manual

Inside you will find many helpful hints on how to use and maintain your unit properly. Just a little preventative care on your part can save you a great deal of time and money over the life of your unit. You will find many answers to common problems inside this manual.

CAUTION

- Contact the authorized service center for repair of this unit
- This unit is not intended for use by young children or infirm persons, without Supervision.
- Young children should be supervised to ensure that they do not play with the appliance.
- If the power cord is damaged it must be repaired by an authorized agent of Omega Altise

SAFETY RULES

To prevent injury to the user or other people and to prevent property damage, the following instructions must be followed. Incorrect operation due to not reading the instructions may cause harm or damage.

- Your portable air conditioner unit should be used in such a way that it is protected from moisture (e.g. condensation or water) do not store or place the unit where it can fall from an elevated surface.
- Always transport the unit in a vertical position and stand it on a stable, level surface during operation.
- Turn off the unit when not in use.

- Always contact an authorized qualified service agent to carry out repairs.
- If the supply cord is damaged it must be repaired by a qualified repairer
- Keep the area clear around the unit. There needs to be an air path of a Minimum of 50cm all around the unit from walls, furniture and curtains.
- If the unit is knocked over during use turn off the unit and unplug it from the power point.
- Do not operate the unit in a wet room such as a bathroom or laundry
- Do not touch the unit with wet hands
- Do not press buttons on the unit with anything but fingers.
- Do not remove fixed covers. Do not use this unit if it is malfunctioning or has been dropped or damaged
- Never use the power point switch to start or stop the unit. Use the control panel first.
- Do not obstruct the inlet or outlet grills
- Do not use harsh chemicals to clean the unit.
- Do not run the unit near dangerous chemicals and or hazardous chemicals.
- Do not use this unit for functions other than those described in this instruction manual.

ENERGY SAVING

- Use the unit in the recommended room size
- Locate the unit where furniture cannot obstruct air flow
- Keep blinds and curtains closed to keep out the sun
- Keep the filters clean
- Keep doors and windows closed to keep cool air in and hot air out

Placement and Installation

Placement

Place the unit on flat and dry ground, and keep at least 50 cm from walls etc. (figure 1)

Installation

- Spin slide bar connector into exhaust hose first, then spin the exhaust hose into exhaust connector (counter-clockwise).
- Put slide bar connector into adjustable slide bar, adjust window open width in order slide bar match window well, and the length of slide bar is adjustable. (figure 2)

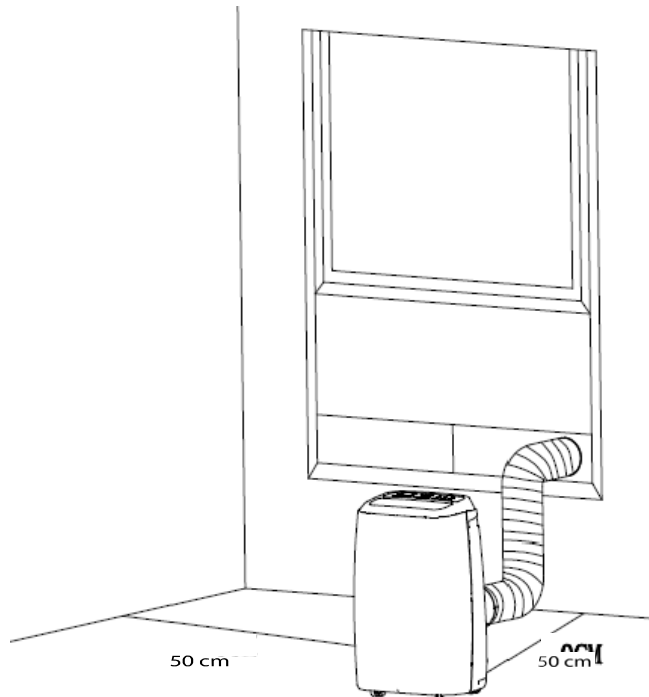

FIGURE 1

Installation Errors

- Free access of exhaust pipe is important; If air is not taken out it will affect performance of the appliance.
- Avoid sharp bends in the exhaust-pipe (figure 2)
- Make sure air in exhaust pipe can run smoothly (figure 3)

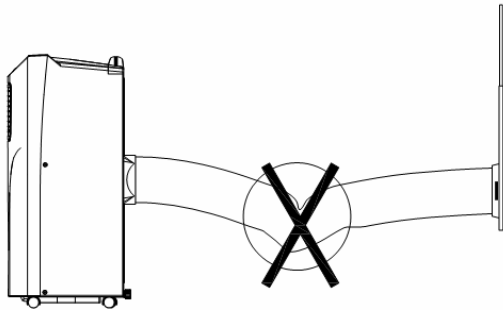

FIGURE 2

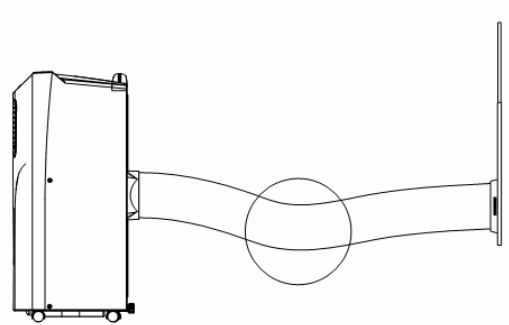

FIGURE 3





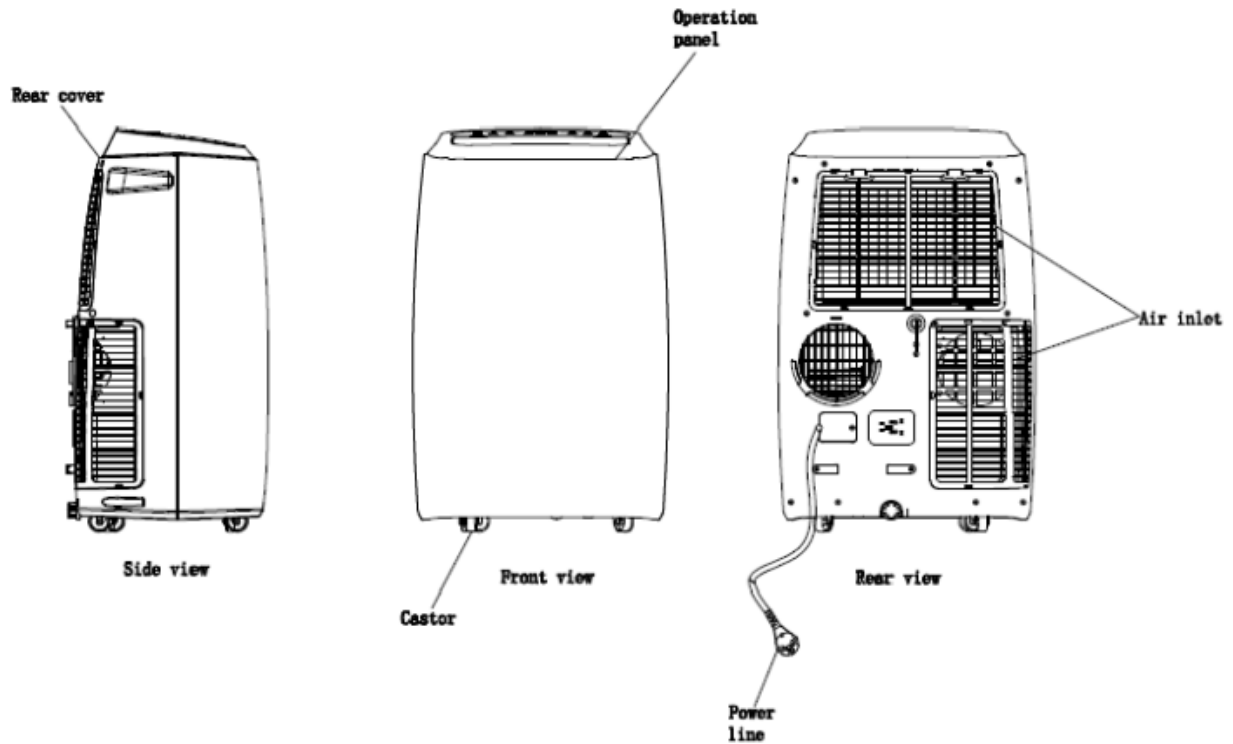

Warning

Use only the exhaust pipe supplied. Longer or extended pipes may damage the appliance

Note: extreme length of unfolding exhaust pipe is 1500mm, please shorten the length as much as possible and keep it level as much as possible when installing

Parts List



Part	Description	Quantity
	Main Air Conditioner Unit	1
	Hot-Air exhaust hose	1
	Hose Connector (Window end)	1
	Hose Connector (Air Conditioner end)	1
	Window Kit	1
	Remote Control	1

Control Panel

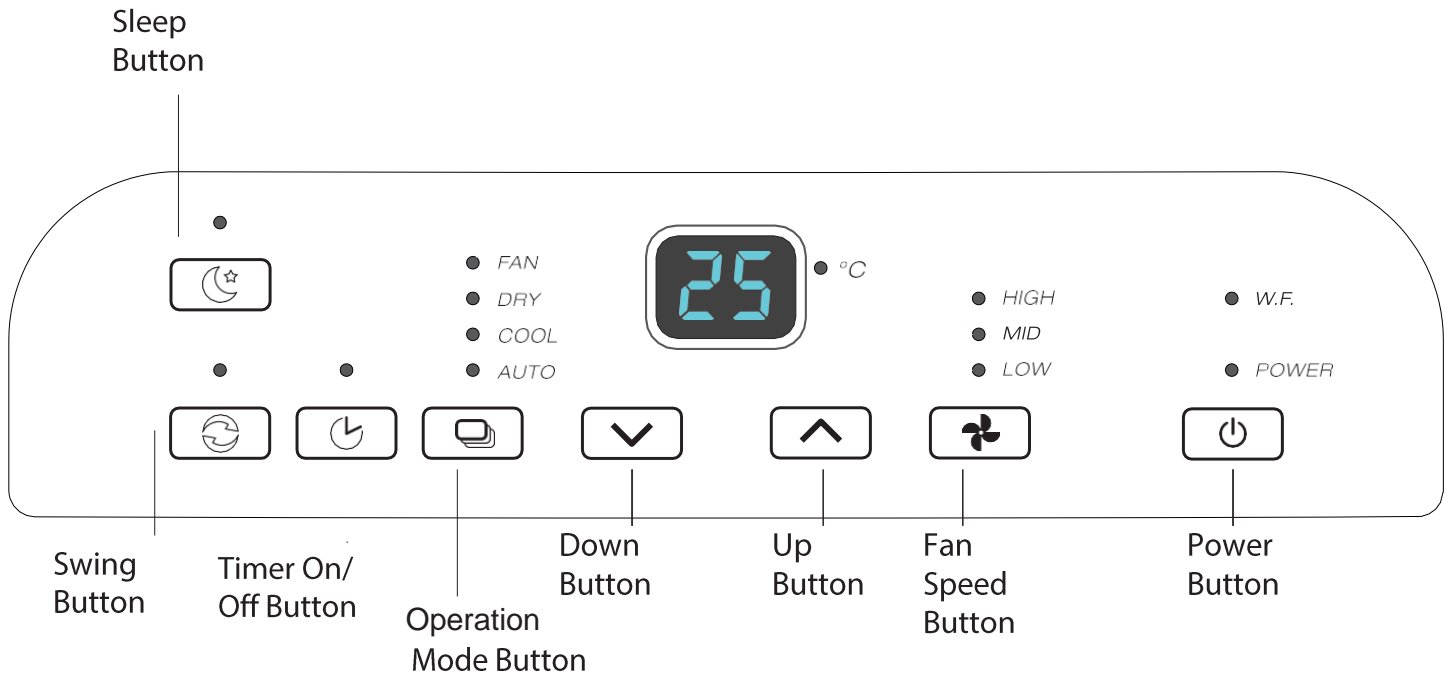

1. **POWER:** press this key to turn unit On or Off. After unit turns on, default value is cooling mode with low fan speed.
2. **OPERATION MODE BUTTON:** after unit turns on, for cooling only model, press this key to select the other modes: Fan, Dry/dehumidify, Cool or Auto.
3. **FAN SPEED:** after unit turns on, press this key to select between 3 fan speeds (high, medium or low).
4. **DOWN:** under cooling mode, press this key to downward setting temperature from 16~31~ ; under timer mode, press this key to downward on/offtime.
5. **UP:** under cooling mode, press this key to upward temperature from 16 ~31~; under timer mode, press this key to upward on/off timer.
6. **SLEEP:** under cooling, press this key to turn on/off sleep function.
7. **ON/OFF TIMER:** When the unit is in standby/off mode press Timer to between 1 -24 hours and it will turn on after selected time is reached.

When the unit is in On mode press the timer to between 1 – 24 hours and it will Turn off after the selected time is reached.

NOTE: Once the unit has been operated, the unit will revert to the settings prior to it being switched off.

Remote Control

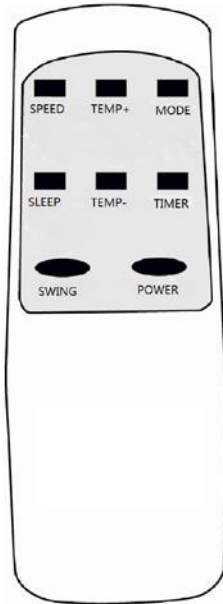

- 1: POWER, On/ Off Switch
- 2: MODE, Fan, Dry, cool and Auto
- 3: TIMER, Hourly Programming
- 4: FAN SPEED, Fan Speed Selector – high medium or low
- 5: TEMP+, Temperature Selector Up
- 6: TEMP-, Temperature Selector Down
- 7: SLEEP, Night Operation Selector
- 8: SWING, Vertical auto Air Flow Selector

Operation Methods

Auto Mode

According to the current room temperature, once you select AUTO it automatically selects the relevant mode.

Cooling Mode

- After machine turns on, the unit will revert to setting that was last used.
- Press “OPERATING MODE BUTTON” to select cooling mode, once this option is selected cooling mode indicator turns on.
- Press “UP” or “DOWN” to adjust temperature (from 16° to 31°).
- Press “FAN Speed Button” to select high, Medium or low fan speeds.

Fan Mode

- Press “OPERATING MODE BUTTON” to select fan mode, once this option is selected fan mode indicator will turn on.
- Press “FAN Speed Button” to select high, Medium or low fan speeds.
- Temperature and sleep function cannot be setup in this mode.

Timer Mode

- When in off/ standby, press "TIMER" to setup the power-on timer, press "UP or "DOWN" to adjust the timer (from 1-24 hours) press "TIMER" to confirm selection.
- "Under power-on mode, press "TIMER" to setup power-off, Press "UP or "DOWN" to adjust the timer (from 1-24 hours) press "TIMER" to confirm selection

Dry/ Dehumidifying Mode

- Press "OPERATING MODE BUTTON" to select dehumidifying mode, once this option is selected dehumidifying mode indicator turns on.
- Under dehumidifying mode fan speed is low.
- Temperature and sleep function cannot be setup in this mode.

Sleep Mode

- Press "SLEEP" to enter into sleeping mode, default value of fan speed is low.
- Sleep mode is invalid under dehumidifying and fan mode. Under water full, machine standby and mode conversion, sleep mode will be cancelled.

Compressor Protection

If turned ON/OFF/ON at startup it takes 3 minutes for the compressor to start.

Water Drainage

This unit has an auto-water-evaporating system. Condensed-water cycle is used to cool down the condenser, which not only improves cooling efficiency, but also saves energy.

- If inner water tank is full, "W.F" indicator will flash on the screen, after 8 seconds the machine goes into standby mode, the buzzer beeps, the compressor stops and all keys are invalid.
- Power off and unplug the unit, pull out the drainage plug at the back bottom of the unit to drain the water, reinstall drainage plug, power on the machine to resume normal operation.

When in Dehumidify mode, this unit has a continuous draining option. This is done by using the drain hose supplied. Simply install the hose into the top black hole supplied.

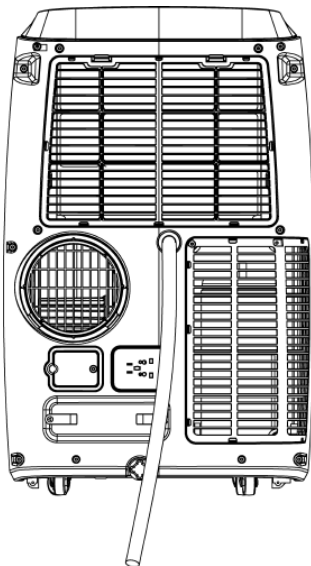

Maintenance

Note: in order to avoid electric shocks, please turn off at the control panel, switch off the power point then unplug the appliance before cleaning

Cleaning

- Please switch off at the control panel, then at the power point then unplug before cleaning.
- Use soft semi-dry cloth to clean the machine. Don't use chemical agents, such as benzene, alcohol, gasoline etc.; otherwise the machine surface can be damaged.
- Use only a moist cloth not a wet or dripping cloth as if water enters the control panel or the machine it will cause damage.

-

Filter

- Clean the filters as required, or every two weeks, if filters are blocked by dust, machine efficiency will be reduced.
- Clean the filters in warm water with neutral detergent then dry the cleaned filters in the shade.

Note: Don't run the machine without filters.

Seasonal Cleaning

If the unit is not being used for a long time, please follow these steps.

- Pull out drainage plug upper / lower to empty any water out.
- Let the unit run under fan mode for 2 hours to dry out the machine internals
- Turn off the unit, switch off the power point and remove the plug.
- Clean and dry filters then reinstall them.
- Pull out exhaust pipe for safe keeping.
- Put the unit into a plastic bag and place it in a dry place.

Troubleshooting

Please contact professional serviceman without delay in following situation

Trouble	Cause	Solution
Machine cannot work	Power off	Power on
	“P2” flashes on screen or water-full indicator turns on	Drain water out
	Timer-off turns on	Turn off machine for three minutes, Then restart it.
Machine auto-restarts frequently	Direct sunlight	Draw the curtains
	Door and windows are open , many heat sources in the room.	Close the door and windows, move out heat sources.
	Filters are too dirty.	Clean or replace filters
	Air-inlet or air out-let is blocked	Remove blockage
Too noisy	Machine is not on flat ground.	Place it on flat and solid ground, avoiding shaking
Compressor cannot work	Compressor time-delay protection turns on	Wait for 3 minutes, then restart the Machine after temperature reduces.

Note: If the machine is not working please contact your authorized agent.

Technical Data

Model	OAPC147	
Cooling capacity	BTU/h	14000
Mains	220-240V/50Hz/1Ph	
Power consumption	W	1538
Current	A	7
Refrigerant	R410A	
Compressor	Rotary	
Fan speeds	3	
Thermostat	°C	16-31
Timer	h	0-24
Dimensions(W*H*D)	mm	470 x 715 x 335
Gross weight	kg	28

Appendix A

Circuit Diagram

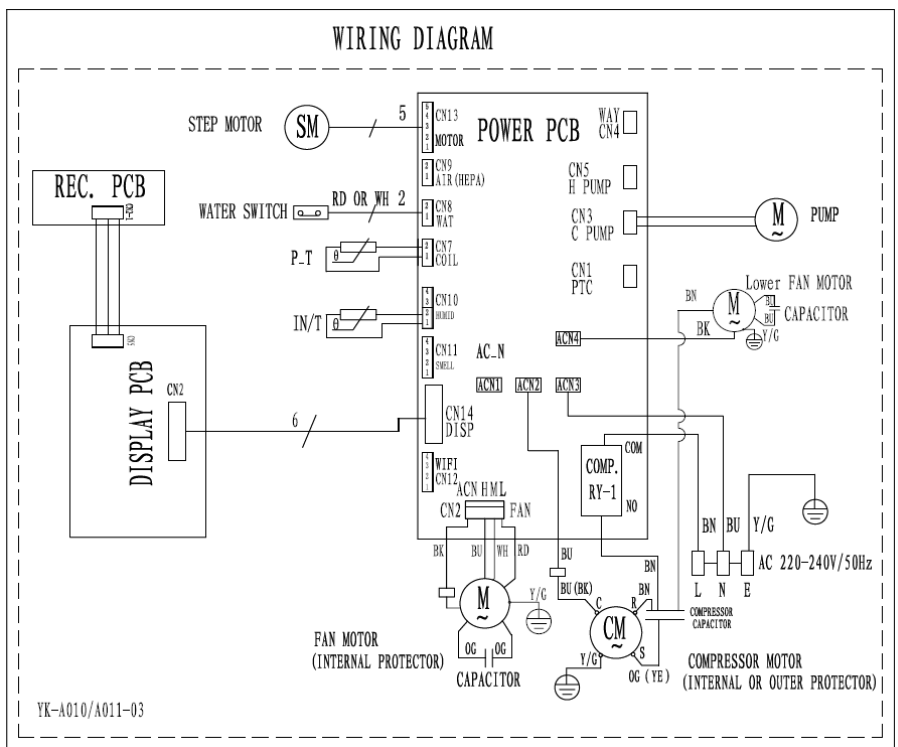

Omega Altise products are distributed in
Australia by Shriro Australia Pty Ltd.
Locked Bag 5002, Kingsgrove NSW 2208
Phone: 1300 795 572 Fax: (02) 9415 5525
Web: <http://www.omegaaltise.com.au>

omega
altise

