

# Owner's Manual

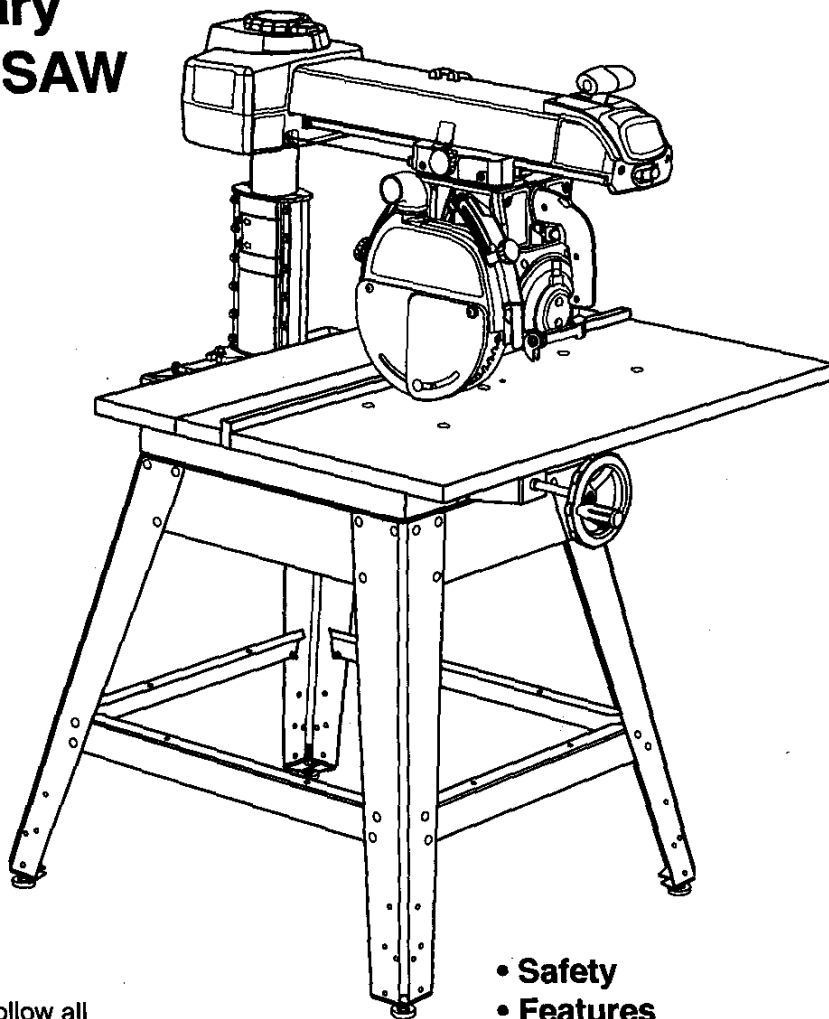

## 10 in. Stationary RADIAL ARM SAW

Model No.  
315.220381



Save this manual for  
future reference.

**CAUTION:** Read and follow all  
Safety Rules and Operating  
Instructions before first use of this  
product.

Customer Help Line: 1-800-932-3188

Sears, Roebuck and Co., Hoffman Estates, IL 60179 USA  
Visit the Craftsman web page: [www.sears.com/craftsman](http://www.sears.com/craftsman)

972000-705  
10-99

- Safety
- Features
- Assembly
- Operation
- Maintenance
- Parts List



## WARRANTY

### FULL ONE YEAR WARRANTY ON CRAFTSMAN RADIAL ARM SAW

If this **CRAFTSMAN** Radial Arm Saw fails due to a defect in material or workmanship within one year from the date of purchase, Sears will repair it, free of charge.

Contact a Sears Service Center for repair.

If this product is used for commercial or rental purposes, this warranty applies only for 90 days from the date of purchase.

This warranty gives you specific legal rights, and you may also have other rights which vary from state to state.

Sears, Roebuck and Co., Dept. 817WA, Hoffman Estates, IL 60179

## INTRODUCTION

Your saw has many features for making cutting operations more pleasant and enjoyable. Safety, performance and dependability have been given top priority in the design of this saw making it easy to maintain and operate.

**CAUTION:** Carefully read through this entire owner's manual before using your new saw. Pay close attention to the Rules For Safe Operation, and all Safety Alert Symbols, including Danger, Warning and Caution. If you use your saw properly and only for what it is intended, you will enjoy years of safe, reliable service.

Look for this symbol to point out important safety precautions. It means attention!!! Your safety is involved.

### **WARNING:**



The operation of any power tool can result in foreign objects being thrown into your eyes, which can result in severe eye damage. Before beginning power tool operation, always wear safety goggles or safety glasses with side shields and a full face shield when needed. We recommend Wide Vision Safety Mask for use over eyeglasses or standard safety glasses with side shields, available at Sears Retail Stores.

## TABLE OF CONTENTS

■ Warranty and Introduction .....	2
■ Table of Contents .....	2-3
■ Rules For Safe Operation .....	4-7
■ Electrical .....	8-9
■ Product Specifications and Glossary .....	10-11
■ Unpacking and Accessories .....	11
■ Loose Parts List .....	12-14
■ Tools Needed .....	15
■ Labels .....	16-17
■ Features .....	18-21
■ Assembly .....	22-36
Assembling Leg Stand .....	22
Mounting Saw to Leg Stand .....	23

## TABLE OF CONTENTS

Attaching Elevating Handwheel .....	23
Installing the Yoke Assembly .....	24
Removing the Blade .....	25
Attaching Table Supports .....	25
Setting the Arm Lock Knob .....	26
Setting the Yoke Clamp .....	26
Setting the Bevel Lock Lever .....	27
Tightening the Arm and Column .....	28
Adjusting the Column Tube .....	28-29
Adjusting the Carriage Bearings .....	30
Leveling the Table Supports .....	31
Installing the Front Table .....	32
Leveling the Front Table .....	33
Installing Rear Table, Spacer Table, Fence, and Clamps .....	33-34
Installing Blade and Blade Guard .....	34
Aligning Riving Knife to Blade .....	35
Installing Rip Scale Indicators .....	36
■ Adjustments .....	36-42
Aligning the Arm for Cross Cuts .....	37
Aligning the Blade to Table at 0° Bevel .....	38
Squaring Blade to Fence .....	39
Paralleling Blade to Table .....	40
Aligning the Rip Scale Indicators .....	41
Installing Control Cut Device .....	42
■ Operation .....	43-53
Basic Operation of the Radial Arm Saw .....	43
Types of Cuts .....	43
Switch and Switch Key .....	44
Causes of Kickback .....	44
Avoiding Kickback .....	44
Cutting Aids .....	45
Making a Cross Cut .....	46
Making a Miter Cut .....	47
Making a Bevel Cut .....	48
Making a Compound Cross Cut .....	49
Rip Cut Hazards and Precautions .....	50
Setting Up a Rip Cut .....	50-51
Making a Rip Cut .....	51
Making Other Cuts .....	52
Cutting Long Workpieces .....	52
Non-Through Cuts .....	53
■ Maintenance .....	54
■ Troubleshooting .....	55-59
■ Exploded View and Repair Parts List .....	60-81
■ Parts Ordering / Service .....	back page

## RULES FOR SAFE OPERATION

The purpose of safety symbols is to attract your attention to possible dangers. The safety symbols, and the explanations with them, deserve your careful attention and understanding. The safety warnings do not by themselves eliminate any danger. The instructions or warnings they give are not substitutes for proper accident prevention measures.

### SYMBOL MEANING



#### **SAFETY ALERT SYMBOL**

Indicates danger, warning or caution. May be used in conjunction with other symbols or pictographs.



**DANGER:** Failure to obey a safety warning will result in serious injury to yourself or to others. Always follow the safety precautions to reduce the risk of fire, electric shock and personal injury.



**WARNING:** Failure to obey a safety warning can result in serious injury to yourself or to others. Always follow the safety precautions to reduce the risk of fire, electric shock and personal injury.



**CAUTION:** Failure to obey a safety warning may result in property damage or personal injury to yourself or to others. Always follow the safety precautions to reduce the risk of fire, electric shock and personal injury.

**Note:** Advises you of information or instructions vital to the operation or maintenance of the equipment.

### IMPORTANT

Servicing requires extreme care and knowledge of the system and should be performed only by a qualified service technician. For service we suggest you contact your nearest Sears repair center. Always use original factory replacement parts when servicing.

If you have questions about terms in the following rules, refer to the Glossary of Terms for Woodworking or the Features section.



**WARNING:** Do not attempt to operate this tool until you have read thoroughly and understand completely all instructions, safety rules, etc. contained in this manual. Failure to comply can result in accidents involving fire, electric shock, or serious personal injury. Save owner's manual and review frequently for continuing safe operation, and instructing others who may use this tool.

### READ ALL INSTRUCTIONS

- **KNOW YOUR POWER TOOL.** Read the owner's manual carefully. Learn the saw's applications and limitations as well as the specific potential hazards related to this tool.
- **DO NOT USE IN DANGEROUS ENVIRONMENT.** Do not use power tools near gasoline or other flammable liquids, in damp or wet locations, or expose them to rain. Keep the work area well lit.
- **KEEP CHILDREN AND VISITORS AWAY.** All visitors should wear safety glasses and be kept a safe distance from work area. Do not let visitors contact the tool or extension cord while operating.
- **KEEP WORK AREA CLEAN.** Cluttered work areas and work benches invite accidents. **DO NOT** leave tools or pieces of wood on the saw while it is in operation. Keep floors clean and free of sawdust.
- **MAINTAIN TOOLS WITH CARE.** Keep tools sharp and clean for better and safer performance. Follow instructions for lubricating and changing accessories.
- **MAKE WORKSHOP CHILD-PROOF** with padlocks and master switches or by removing switch keys.
- **USE THE RIGHT TOOL FOR THE JOB.** Do not force the tool or attachment to do a job it was not designed for. Use it only the way it was intended.
- **DRESS PROPERLY.** Do not wear loose clothing, gloves, neckties, rings, bracelets, or other jewelry. They can get caught and draw you into moving parts. Nonslip footwear is recommended. Also wear protective hair covering to contain long hair.
- **ALWAYS WEAR SAFETY GLASSES WITH SIDE SHIELDS.** Everyday eyeglasses have only impact-resistant lenses; they are **NOT** safety glasses.
- **NEVER STAND ON TOOL.** Serious injury could occur if the tool is tipped or if the blade is unintentionally contacted.
- **DO NOT OVERREACH.** Keep proper footing and balance at all times.
- **SECURE WORK.** Use clamps or a vise to hold work when practical. It's safer than using your hand and frees both hands to operate the tool.

## RULES FOR SAFE OPERATION (Continued)

- **USE THE PROPER EXTENSION CORD.** Make sure your extension cord is in good condition. Use only a cord heavy enough to carry the current your product will draw. An undersized cord will cause a drop in line voltage resulting in loss of power and overheating. A wire gage size (A.W.G.) of at least 14 is recommended for an extension cord 25 feet or less in length. If in doubt, use the next heavier gage. The smaller the gage number, the heavier the cord.
  - **AVOID ACCIDENTAL STARTING.** Be sure switch is off when plugging in the tool.
  - **REMOVE WRENCHES AND ADJUSTING KEYS.** Get in the habit of checking - before turning on the tool - that hex keys and adjusting wrenches are removed from tool.
  - **CHECK DAMAGED PARTS.** Before using the tool again, check any damaged parts, including guards, for proper operation and performance. Check alignment of moving parts, binding of moving parts, breakage of parts, saw stability, mounting, and any other conditions that may affect its operation. A damaged part must be properly repaired or replaced by a qualified service technician at a Sears repair center to avoid risk of personal injury.
  - **USE ONLY CORRECT BLADES.** Use the right blade style for the material and the type of cut. Use only blades marked for at least 5,000 rpm and 10 in. or smaller, with a 5/8 in. arbor hole.
  - **KEEP GUARDS IN PLACE** and in good working order. This includes the blade guard, the riving knife, and the anti-kickback pawls.
  - **CHECK DIRECTION OF FEED.** When ripping, feed work into a blade or cutter against the direction of rotation of the blade or cutter.
  - **NEVER LEAVE TOOL RUNNING UNATTENDED. TURN THE POWER OFF.** Do not leave the tool until it comes to a complete stop.
  - **USE RECOMMENDED ACCESSORIES.** Using improper accessories may risk injury. Consult the *Accessories* section for recommended accessories.
  - **USE ONLY SEARS REPLACEMENT PARTS.** All repairs, whether electrical or mechanical, should be made by a qualified service technician at a Sears repair center.
  - **DISCONNECT ALL TOOLS.** When not in use, before servicing, or when changing attachments, blades, bits, cutters, etc., all tools should be disconnected from the power supply.
  - **DO NOT FORCE THE TOOL.** It will do the job better and more safely at the rate for which it was designed.
  - **BEFORE MOUNTING, DISCONNECTING OR REMOUNTING THE MOTOR;** unplug the saw and remove the switch key.
- ⚠ WARNING:** When servicing, use only identical Craftsman replacement parts. Use of any other parts may create a hazard or damage product.
- **NEVER USE THIS TOOL IN AN EXPLOSIVE ATMOSPHERE.** Normal sparking of the motor could ignite fumes.
  - **MAKE SURE THE WORK AREA HAS AMPLE LIGHTING** to see the work and that no obstructions will interfere with safe operation **BEFORE** performing any work using this tool.
  - **DO NOT USE TOOL IF SWITCH DOES NOT TURN IT ON AND OFF.** Have defective switches replaced by a qualified service technician at a Sears repair center.
  - **GUARD AGAINST ELECTRICAL SHOCK** by preventing body contact with grounded surfaces such as pipes, radiators, ranges, refrigerator enclosures.
  - **GROUND ALL TOOLS.** See Electrical page.
  - **WEAR A DUST MASK** to keep from inhaling fine particles. Use wood dust collection systems whenever possible.
  - **PROTECT YOUR HEARING.** Wear hearing protection during extended periods of operation.
  - **DO NOT OPERATE THIS TOOL WHILE UNDER THE INFLUENCE OF DRUGS, ALCOHOL, OR ANY MEDICATION.**
  - **STAY ALERT AND EXERCISE CONTROL.** Watch what you are doing and use common sense. **Do not operate tool when you are tired. Do not rush.**
  - **AVOID AWKWARD OPERATIONS AND HAND POSITIONS** where a sudden slip could cause your hand to move into the blade. **ALWAYS** make sure you have good balance.

## RULES FOR SAFE OPERATION (Continued)

- **GUARD AGAINST KICKBACK.** Kickback can occur when the blade stalls, driving the work piece back toward the operator. It can cause your hand to contact the blade, resulting in serious personal injury. Stay out of the blade path and turn switch off immediately if blade binds or stalls.
  - **DO NOT USE A PERSON AS A SUBSTITUTE FOR A TABLE** if additional support is needed. Use a support the same height as the table.
  - **USE A SUPPORT FOR THE SIDES AND BACK OF THE SAW TABLE** when sawing wide or long workpieces to minimize the risk of blade pinching and kickback. Use a sturdy “outrigger” support to prevent tipping if a table extension more than 24 inches long is attached to the saw.
  - **CUT ONLY WOOD, PLASTIC OR WOOD-LIKE MATERIALS.** Do not cut metal.
  - **BEFORE MAKING A CUT,** be sure all adjustments are secure.
  - **NEVER** cut more than one piece at a time. **DO NOT STACK** more than one workpiece on the saw table at a time.
  - **DO NOT REMOVE THE SAW'S BLADE GUARD.** Never operate the saw with the blade guard removed. Make sure all guards are operating properly before each use.
  - **NEVER PERFORM ANY OPERATION FREE-HAND.** Always place the workpiece to be cut on the saw table and position it firmly against the fence as a backstop.
  - **USE THE RIP FENCE.** Always use a fence or straight edge guide when ripping.
  - **BE SURE THE BLADE PATH IS FREE OF NAILS.** Inspect for and remove all nails from lumber before cutting.
  - **BE SURE THE BLADE CLEARS THE WORKPIECE.** Never start the saw with the blade touching the stock.
  - **KEEP HANDS AWAY FROM CUTTING AREA.** Do not reach underneath work or in blade cutting path with your hands and fingers for any reason. Always turn the power off when cut is complete.
  - **USE A PUSHBLOCK OR PUSHSTICK** in rip mode for workpieces so small that your fingers go under the blade guard. **NEVER TOUCH BLADE** or other moving parts during use, for any reason.
  - **ALLOW THE MOTOR TO COME UP TO FULL SPEED** before starting a cut to avoid blade binding or stalling.
  - **ALWAYS PUSH THE WORKPIECE** when ripping; never pull it toward the saw.
  - **DO NOT FEED THE MATERIAL TOO QUICKLY.** Do not force the workpiece against the blade.
  - **ALWAYS TURN OFF SAW** before disconnecting it, to avoid accidental starting when reconnecting to the power supply. **NEVER** leave the saw unattended while connected to a power source.
  - **BEFORE CHANGING THE SETUP, REMOVING COVERS, GUARDS, OR BLADE;** unplug the saw and remove the switch key.
  - **KEEP TOOL DRY, CLEAN, AND FREE FROM OIL AND GREASE.** Always use a clean cloth when cleaning. Never use brake fluids, gasoline, petroleum-based products, or any solvents to clean tool.
  - **KEEP BLADES CLEAN, SHARP AND WITH SUFFICIENT SET.** Sharp blades minimize stalling and kickback. Keep blades free of rust, grease, and pitch.
-  **WARNING:** Blade coasts after being turned off.
- **USE ONLY OUTDOOR EXTENSION CORDS.** Use only extension cords with the marking “Acceptable for use with outdoor appliances; store indoors while not in use.” Use extension cords with an electrical rating not less than the saw's rating. Always disconnect the extension cord from the outlet before disconnecting the product from the extension cord.
  - **INSPECT TOOL CORDS AND EXTENSION CORDS PERIODICALLY** and, if damaged, have repaired by a qualified service technician at a Sears repair center. Stay constantly aware of cord location and keep it well away from the moving blade.
  - **DO NOT ABUSE CORD.** Never yank the cord to disconnect it from receptacle. Keep the cord from heat, oil, and sharp edges.
  - **SAVE THESE INSTRUCTIONS.** Refer to them frequently and use to instruct other users. If you loan someone this tool, loan them these instructions also.

## SAVE THESE INSTRUCTIONS

## ADDITIONAL SAFETY RULES FOR RADIAL SAWS

- **SECURE THE SAW.** Firmly bolt the saw to the leg stand to keep the saw from tipping, walking, or sliding.
  - **DO NOT SET UP WORK WITH THE BLADE SPINNING.** Keep the saw power off until you are ready to use it.
  - **RIP ONLY WORKPIECES LONGER THAN THE BLADE'S DIAMETER.** Never rip a piece of wood that is shorter than the diameter of the blade.
  - **NEVER LOWER AN UNLOCKED REVOLVING CUTTING TOOL.** Always lock the carriage lock knob before lowering the blade.
  - **SHUT OFF THE POWER TO FREE A JAMMED GUARD.** Press the switch off before putting your hands near the blade. Wait for the blade to stop, then free the guard.
  - **LOCK THE SAW BEFORE MOVING IT.** Secure the radial arm with the arm lock knob. Secure the carriage with the carriage lock knob.
  - **POSITION THE WORKPIECE WITH THE FINISHED SIDE DOWN.** If the anti-kickback pawls catch the wood to stop kickback, they could mar the top surface or cause splintering.
  - **POSITION THE WORKPIECE SO NO ONE MUST STAND IN LINE WITH THE BLADE.** If kickback or climb occurs, a helper, operator, or observer in the sawblade path could be seriously injured.
  - **POSITION THE CUT SO THE WASTE PART FALLS OFF.** Never use a length stop on the free end of the workpiece. Never apply force to the free end or hold it while the sawblade is rotating.
- ⚠ WARNING:** In a rip cut, holding the cut-off edge behind the blade can cause the cut edges to pinch, risking kickback. It could cause the blade to climb over the front edge of the wood and contact your hand.
- **BEFORE STARTING EACH CUT,** check that no play exists in the carriage. Be sure the arm, yoke and bevel locks and clamps are tight. Verify the blade, all handles, blade washers, and blade nuts are secure.
  - **BEFORE MAKING A CUT,** test the upper and lower blade guards for free movement up and down. Position the nose of the guard to just clear the workpiece.
  - **AVOID KICKBACK AND POSSIBLE INJURY** by preventing heeling, grabbing, and pinching.
  - **BEFORE CUTTING,** position and tighten the blade guard and anti-kickback pawls. Test the pawls to make sure they would stop kickback if it started. Keep the points sharp.
  - **KEEP THE SAW BLADE PATH CLEAR.** Position the saw to allow enough room on all sides so neither the operator nor a visitor stands in line with the sawblade.
  - **AVOID HEELING** by adjusting the saw blade so it exactly parallels the fence during ripping operations.
  - **AVOID GRABBING** in rip mode by keeping the saw blade correctly adjusted and by feeding the work from the infeed side (opposite the anti-kickback pawls).
  - **AVOID PINCHING** by using a riving knife and sharp saw blade. Keep the work positioned firmly against the fence.
  - **USE IN-RIP WHENEVER POSSIBLE** by positioning the work so the blade is between (inside) the column and the motor.
  - **NEVER ADJUST GUARD, PAWLS, OR BLADE WITHOUT DISCONNECTING THE POWER.** Always turn off the switch and unplug the cord before freeing a jammed blade, tightening a loose blade, or repositioning the guard or pawls.
- ⚠ CAUTION:** Do not turn the motor switch on and off rapidly. This can loosen the sawblade.
- **NEVER CUT MORE THAN ONE PIECE OF WOOD AT A TIME.** The feed will be uneven and could cause the blade to pick up one or more pieces and cause serious injury.
  - **TURN OFF SAW IF A STRANGE NOISE OR HEAVY VIBRATION OCCURS.** Immediately turn off the saw, locate the source, and correct the problem before using the saw further.
  - **POSITION THE CUT SO THE BLADE WILL NOT EXTEND BEYOND THE EDGE OF THE TABLE.**
  - **KEEP THE GUARDS IN PLACE AND THE WORK SURFACE CLEAR DURING A CUT.** Small objects or wood slivers can ricochet from the blade into the fence and back toward the operator. If the blade loosens slivers, remove them with a stick, not your hand.
  - **IN A RIP CUT, DO NOT LET GO OF THE WORKPIECE UNTIL THE CUT IS COMPLETE.** When the workpiece is fed into the blade, push the workpiece all the way past the blade.

# ELECTRICAL

## EXTENSION CORDS

Use only 3-wire extension cords that have 3-prong grounding plugs and 3-pole receptacles that accept the tool's plug. When using a power tool at a considerable distance from the power source, use an extension cord heavy enough to carry the current that the tool will draw. An undersized extension cord will cause a drop in line voltage, resulting in a loss of power and causing the motor to overheat. Use the chart provided below to determine the minimum wire size required in an extension cord. Only round jacketed cords listed by Underwriter's Laboratories (UL) should be used.

Length of Extension Cord	Wire Size (A.W.G.)
Up to 25 feet	14
26-100 feet	12

When working with the tool outdoors, use an extension cord that is designed for outside use. This is indicated by the letters **WA** on the cord's jacket.

Before using an extension cord, inspect it for loose or exposed wires and cut or worn insulation.

**CAUTION:** Keep the cord away from the cutting area and position the cord so that it will not be caught on lumber, tools, or other objects during cutting operations.

## ELECTRICAL CONNECTION

Your Sears Craftsman Radial Arm Saw is powered by a precision built electric motor. It should be connected to a **power supply that is 120 volts, 60 Hz, AC only (normal household current)**. It should be connected to a 240 volt power supply **only if it has been reset according to the instructions** in this manual. The motor has been set at the factory for 120 volts; if it is reconnected to operate at 240 volts, the main power cord plug and any receptacle must be replaced with devices rated for 240 volts. This tool will not operate on direct current (DC). A substantial voltage drop will cause a loss of power and the motor will overheat. If the saw does not operate when plugged into an outlet, double check the power supply.

## SPEED AND WIRING

The no-load speed of your saw is approximately 3,600 rpm. This speed is not constant. For voltage, the wiring in a shop is as important as the motor's horsepower rating. A line intended only for lights cannot properly carry a power tool motor. Wire that is heavy enough for a short distance will be too light for a greater distance. A line that can support one power tool may not be able to support two or three tools.

## GROUNDING INSTRUCTIONS

In the event of a malfunction or breakdown, grounding provides a path of least resistance for electric current to reduce the risk of electric shock. This tool is equipped with an electric cord having an equipment-grounding conductor and a grounding plug. The plug must be plugged into a matching outlet that is properly installed and grounded in accordance with all local codes and ordinances.

Do not modify the plug provided. If it will not fit the outlet, have the proper outlet installed by a qualified electrician. Improper connection of the equipment-grounding conductor can result in a risk of electric shock. The conductor with insulation having an outer surface that is green with or without yellow stripes is the equipment-grounding conductor. If repair or replacement of the electric cord or plug is necessary, do not connect the equipment-grounding conductor to a live terminal.

Check with a qualified electrician or service personnel if the grounding instructions are not completely understood, or if in doubt as to whether the tool is properly grounded.

Repair or replace a damaged or worn cord immediately.

This tool is intended for use on a circuit that has an outlet like the one shown in *Figure 1*. It also has a grounding pin like the one shown.

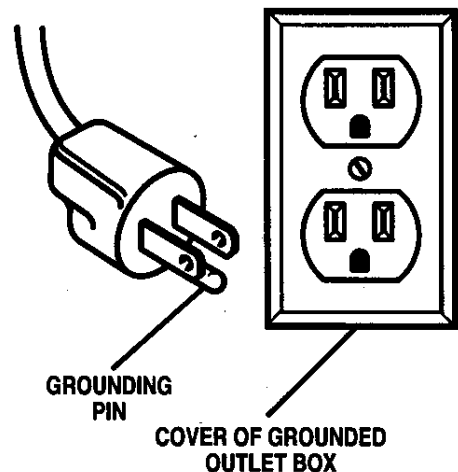

Fig. 1

# ELECTRICAL

## CHANGING VOLTAGE

See Figures 2-4.

Your radial saw has been set up at the factory to operate efficiently on a 120V AC single voltage circuit. However, if heavy duty operation is required, the circuits are overloaded, or the circuit is low voltage, have a qualified electrician change the voltage on the main power system to a 240V AC voltage circuit.

**⚠ WARNING:** The control cut device is set up for a 120V AC single voltage circuit. **Do not modify the control cut cord.** Identify the control cut cord and tie it back out of the way.

- Correctly identify the control cut cord, unplug it, and set it aside.
- Unplug the main power cord.
- Remove the blade following the procedure in the *Assembly* section.
- Remove the pan head screw above the blade arbor on the motor cover. Lift motor cover to expose switch. See *Figure 2*.
- Use a small screwdriver to slide the dual voltage switch to the 240V position. See *Figures 3 and 4*.
- Reinstall motor cover.
- Replace the 120V plug on the main cord with a UL listed 240V, 15 amp, 3-prong plug.
- Follow the instructions provided with the UL listed plug.
- Plug the cord into a 240V, 15 amp, 3-blade receptacle. Make sure the receptacle is connected to a 240V AC power supply through a 240V branch circuit that has a 15 amp fuse or circuit breaker.

**Note:** No adapter is available for this type of plug or receptacle.

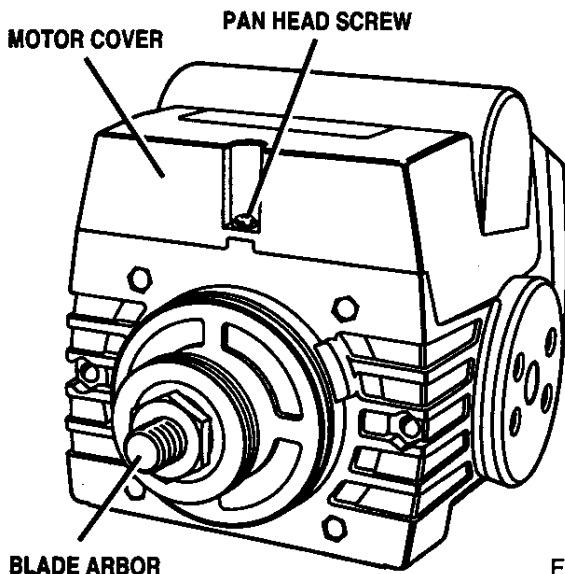
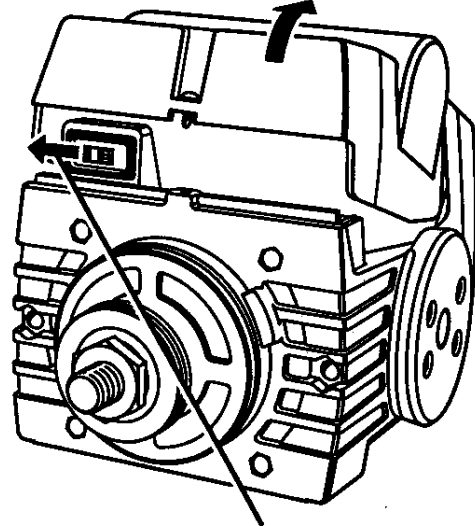

Fig. 2

LIFT MOTOR COVER TO EXPOSE SWITCH



SLIDE AS SHOWN FOR SINGLE VOLTAGE CIRCUITS  
SWITCH SHOWN IN 110-120 VOLT POSITION

Fig. 3

LIFT MOTOR COVER TO EXPOSE SWITCH

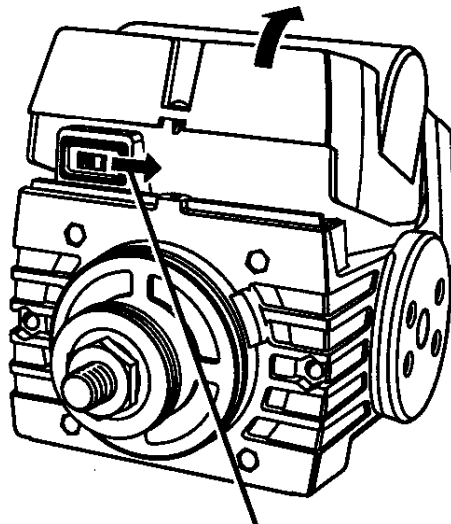

SLIDE AS SHOWN FOR DUAL VOLTAGE CIRCUITS  
SWITCH SHOWN IN 220-240 VOLT POSITION

Fig. 4

## PRODUCT SPECIFICATIONS

Blade Arbor	5/8 in.	Cutting Capacity - Maximum In-Rip	16 in.
Blade Diameter	10 in.	Depth of Cut at 90°	3 in.
Blade Bevel Angle	0° - 90°	Depth of Cut at 45°	2.25 in.
Radial Arm Swing Range	45° minimum left - 90° right	Table Size	40 x 27.75 x 1 in.
Blade Height Adjust	5.35 in.	Table Height	36 in.
Carriage Travel	17.25 in.	Rating	120V/240V 60 Hz - AC only
Cutting Capacity - Maximum Cross Cut	15.50 in.	Input	13.0/6.5 Amperes
Cutting Capacity - Maximum Out-Rip	26 in.	No Load Speed	3,600 RPM

## GLOSSARY OF TERMS FOR WOODWORKING

### Bevel Cut

A cut made across a workpiece with the blade at any angle other than 90° to the table surface.

### Chamfer

A cut removing a wedge from a block so the end (or part of it) is angled rather than at 90 degrees.

### Climb

A hazard in which the blade "climbs" over and out of the workpiece, pulling the stock out of the operator's hands or running across the workpiece.

### Compound Cut

A cross cut with both a miter angle and a bevel angle.

### Cross Cut

A cutting operation with the blade parallel to the carriage arm and the blade teeth pointing down. It can be across or with the grain, normally across the grain or width of the workpiece.

### Dado Cut

A non-through cut that leaves a square notch or trough; requires a special blade.

### Featherboard

A device to help guide workpieces during rip cuts.

### Fence

A piece of wood used as a edge guide for the workpiece. Located perpendicular to the carriage arm. Can be placed at different distances from the rear table edge in combination with the other table pieces and is secured with table clamps.

### Freehand

Dangerous practice of making a cut without using a fence.

### Gum

A sticky, sap-based residue from wood products.

### Heel

Alignment of the blade to the fence.

### Infeed

The side of the blade where the blade teeth point up, opposite the anti-kickback pawls.

### In-Rip

A type of rip cut in which the blade is between the column and the motor.

### Kerf

The space left by the removal of material in a cut or the slot produced by the blade in a non-through cut.

### Kickback

A hazard that can occur when blade binds or stalls, throwing workpiece back toward operator.

### Leading End

The end of the workpiece pushed into the cutting tool first.

### Miter Cut

A vertical cut made at any angle other than 0° across the workpiece.

### Molding

A shaping cut that gives a varied shape to the workpiece and requires a special blade.

### Out-Rip

A type of rip cut in which the motor is between the blade and the column. (The blade is "outside" the motor).

### Pushstick

A device used to feed the workpiece through the saw blade during cutting operations. It helps keep the operator's hands well away from the blade.

### Rabbet

A type of cut that gives a notch in the edge of a workpiece.

### Resaw

A cutting operation to reduce the thickness of the workpiece to make thinner pieces.

## GLOSSARY OF TERMS FOR WOODWORKING (Cont.)

- Resin**  
A sticky, sap-based substance.
- Rip Cut**  
In a radial saw, a cut made with the blade parallel to the fence and perpendicular to the arm. Can be across or with the grain. The teeth point up at the point of contact with the wood.
- Sawblade Path**  
The area directly in line with the blade — over, under, behind, or in front of it. Also, the workpiece area which will be or has been cut by the blade.
- Set**  
The distance that the tip of the saw blade tooth is off set from the face of the blade.
- Throw-Back**  
Saw throwing back a workpiece similar to kickback.
- Through Sawing**  
Any cutting operation where the blade extends completely through the workpiece.
- Trailing End**  
The workpiece end last cut by the blade in a rip cut.
- Workpiece**  
The item on which the cutting operation is being done. The surfaces of a workpiece are commonly referred to as faces, ends, and edges.
- Worktable**  
The surface on which the workpiece rests while performing a cutting operation.

## UNPACKING

**⚠ WARNING:** To prevent accidental starting that could cause possible serious personal injury, assemble all parts to your saw before connecting it to power supply. The saw should never be connected to the power supply when you are assembling parts, making adjustments, installing or removing blades, or when not in use.

**⚠ WARNING:** If any parts are missing, do not operate this tool until the missing parts are replaced. Failure to do so could result in possible serious personal injury.

- Carefully remove all parts from the carton and place the saw on a level work surface. Separate and check against the list of loose parts.
- Do not discard the packing materials until you have carefully inspected the saw, identified all parts, and satisfactorily operated your new saw.

**Note:** If any parts are damaged or missing, do not attempt to plug in the power cord and turn the switch on until the damaged or missing parts are obtained and are installed correctly.

## ACCESSORIES

The following recommended accessories are currently available at Sears Retail Stores.

- Steel and carbide tipped circular saw blades
- Adjustable taper jig
- Hold down clamps
- Sawdust collector shroud
- Saw baskets

**⚠ WARNING:** The use of attachments or accessories not listed might be hazardous.

# LOOSE PARTS LIST

Check all loose parts from the box with the list below. Use the instructions on the following pages to assemble. All fasteners are shown actual size.

1. Saw Assembly ..... 1

SAW ASSEMBLY SHOWN AS PACKED

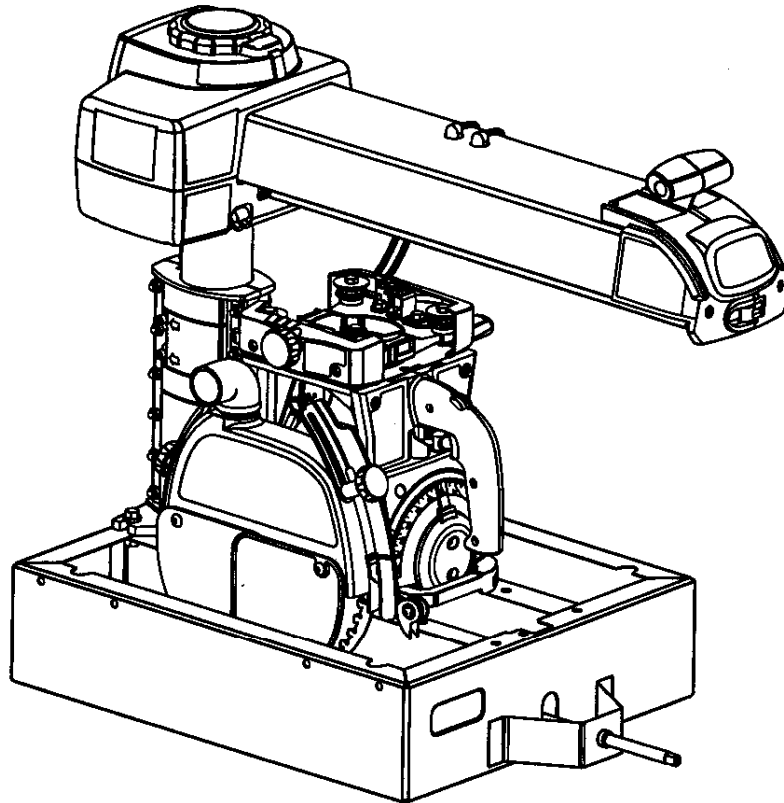
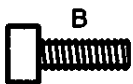
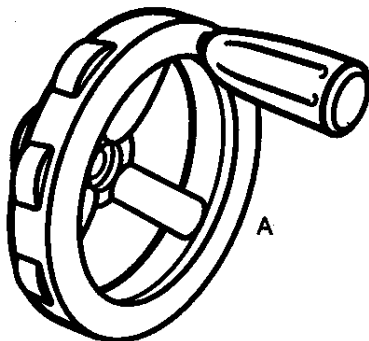
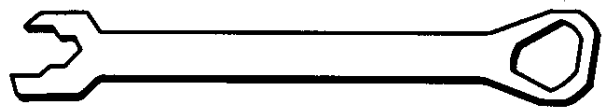

Fig. 5

2. Elevating Handwheel ..... 1
  - A. Handwheel ..... 1
  - B. Screw (10-24 x 5/8 in. Soc. Hd.) ..... 1
  - C. Star Washer ..... 1



3. Blade Wrench ..... 2



4. Hex Key ..... 1
  - A. 3/16 in. Hex Key ..... 1
  - B. 1/4 in. Hex Key ..... 1

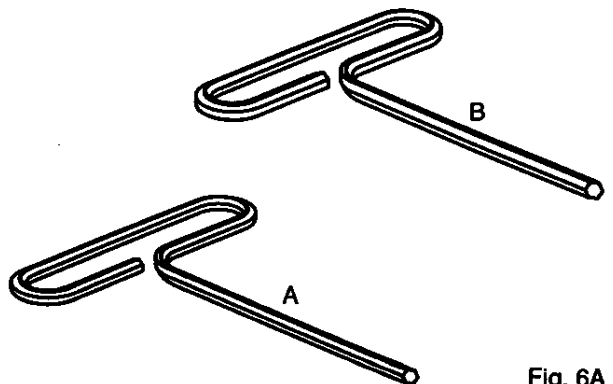
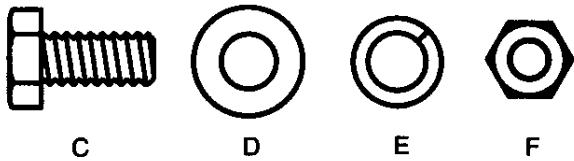

Fig. 6A

## LOOSE PARTS LIST

Check all loose parts from the box with the list below. Use the instructions on the following pages to assemble. All fasteners are shown actual size.

5. Saw Base To Leg Stand Assembly
- A. Saw Assembly (not shown) ..... 1
  - B. Leg Stand Assembly (not shown) ..... 1
  - C. Hex bolt (5/16-18 x 5/8 in. Hex Head) ..... 4
  - D. Washer (5/16 in.) ..... 8
  - E. Lock washer (5/16 in.) ..... 4
  - F. Hex Nut (5/16-18)..... 4



6. Hardware for Front Table
- A. Front table ..... 1
  - B. Screw (1/4-20 x 1 in.) ..... 4
  - C. Washer (1/4 in.) ..... 4
  - D. Lock washer (1/4 in.) ..... 4
  - E. Hex nut (1/4-20) ..... 4

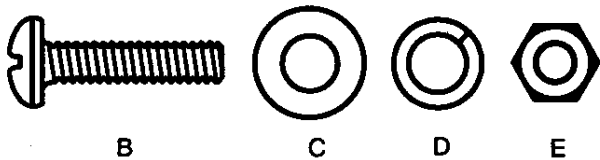
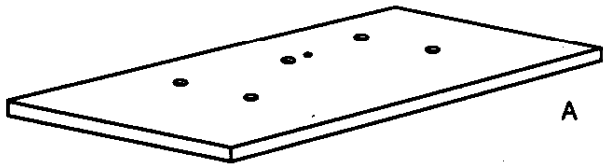

7. Rear Table ..... 1

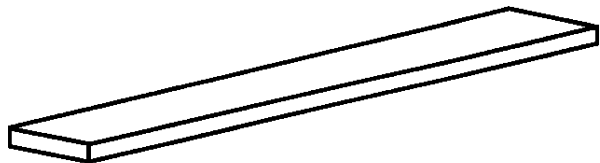

8. Spacer Table ..... 1



9. Fence ..... 1



10. Leveling Hardware for Front Table
- A. Screw (1/4-20 x 1-3/4 in.) ..... 1
  - B. Washer ..... 1
  - C. U-clip ..... 1
  - D. Setscrew ..... 1
  - E. Tee nut ..... 1

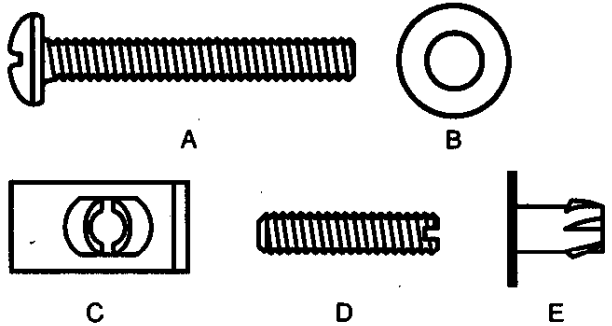

11. Scale Indicator
- A. Screw ..... 4
  - B. Speed Nut ..... 2
  - C. Indicator ..... 2
  - D. Switch Key ..... 2

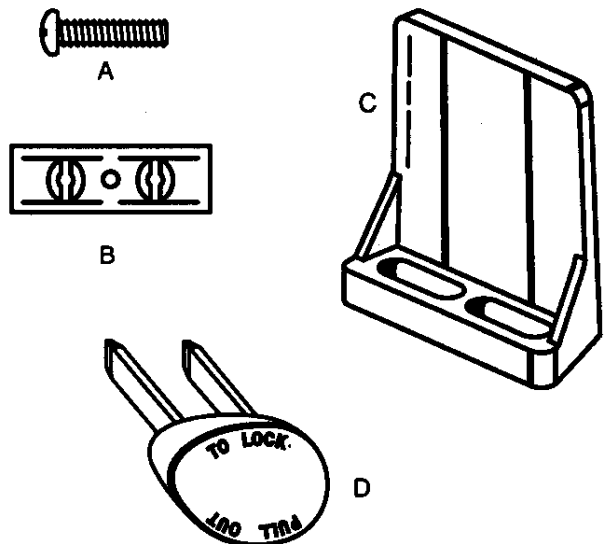
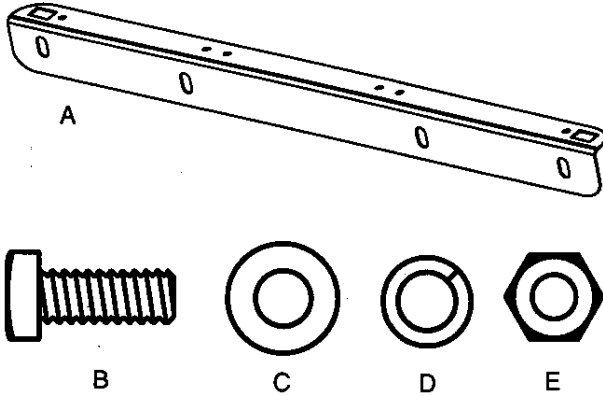

Fig. 6B

# LOOSE PARTS LIST

Check all loose parts from the box with the list below. Use the instructions on the following pages to assemble. All fasteners are shown actual size.

12. Table Support
- A. Table Support Rails ..... 2
  - B. Square head bolt (5/16-18 x 3/4 in.) ..... 4
  - C. Flat washer (5/16 in.) ..... 4
  - D. Lock washer (5/16 in.) ..... 4
  - E. Hex nut (5/16-18) ..... 4



13. Table Clamp ..... 2
- A. Thumb screw (2) ..... 2
  - B. Square nut ..... 2
  - C. Table clamp bracket ..... 2
  - D. Cup washer ..... 2

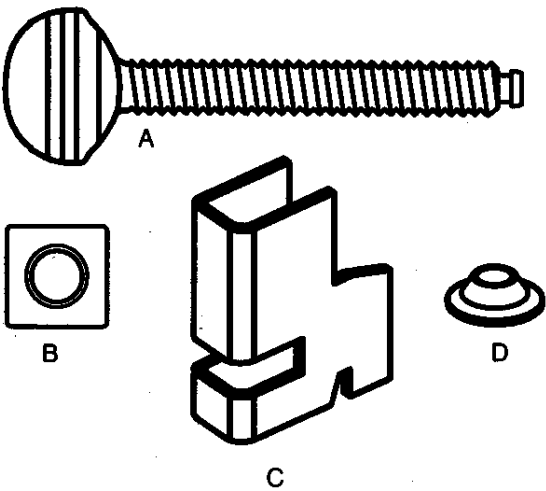

14. Owner's Manual (not shown) ..... 1

15. Leg Stand ..... 1
- A. Leg ..... 4
  - B. Long bottom brace ..... 2
  - C. Long top brace ..... 2
  - D. Short bottom brace ..... 2
  - E. Short top brace ..... 2
  - F. Foot ..... 4
  - G. Screw (1/4-20 x 5/8 in.) ..... 40
  - H. Star washer ..... 40
  - I. Hex nut (1/4-20) ..... 40
  - J. Hex nut (3/8-16) ..... 8

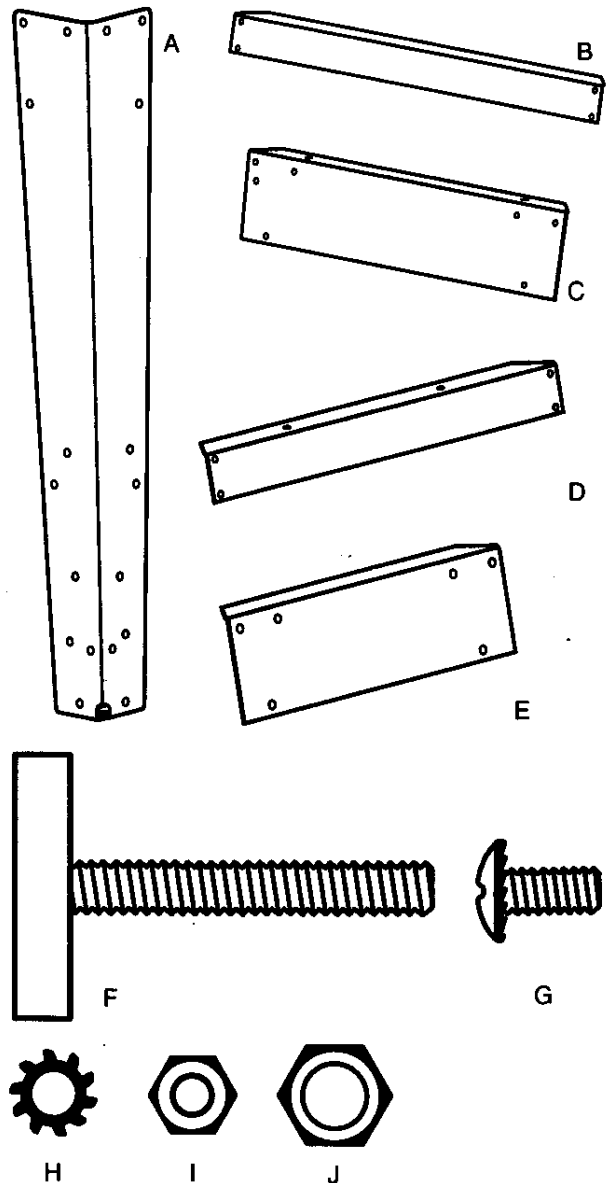
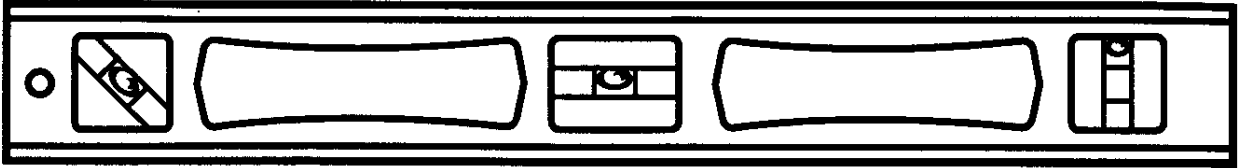

Fig. 6C

# TOOLS NEEDED

The following tools are needed for assembly and alignment. They are not included with this saw.



LEVEL

HEX KEYS:  
5/32 in. AND 1/8 in.

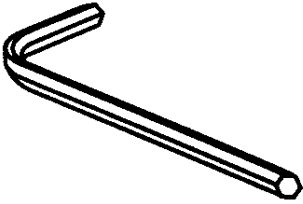

MEDIUM FLAT BLADE SCREWDRIVER



#2 PHILLIPS SCREWDRIVER



PENCIL



SMALL HAMMER

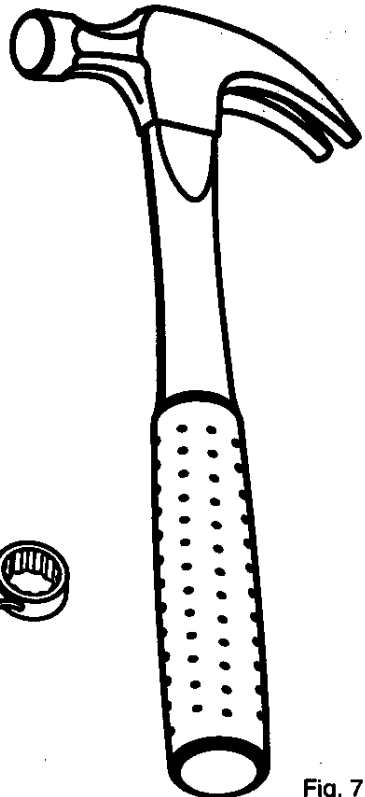

PLIERS

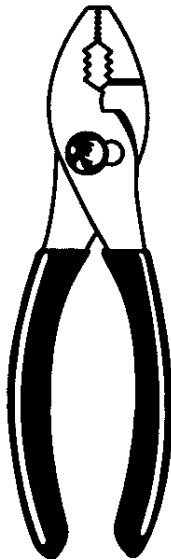

CHANNEL LOCK PLIERS

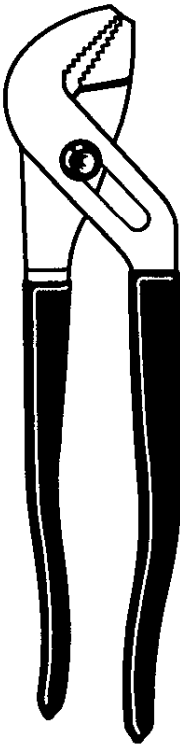

WRENCHES: 7/16 in., 1/2 in., 9/16 in., 15/16 in.

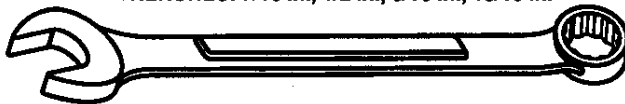

FRAMING SQUARE

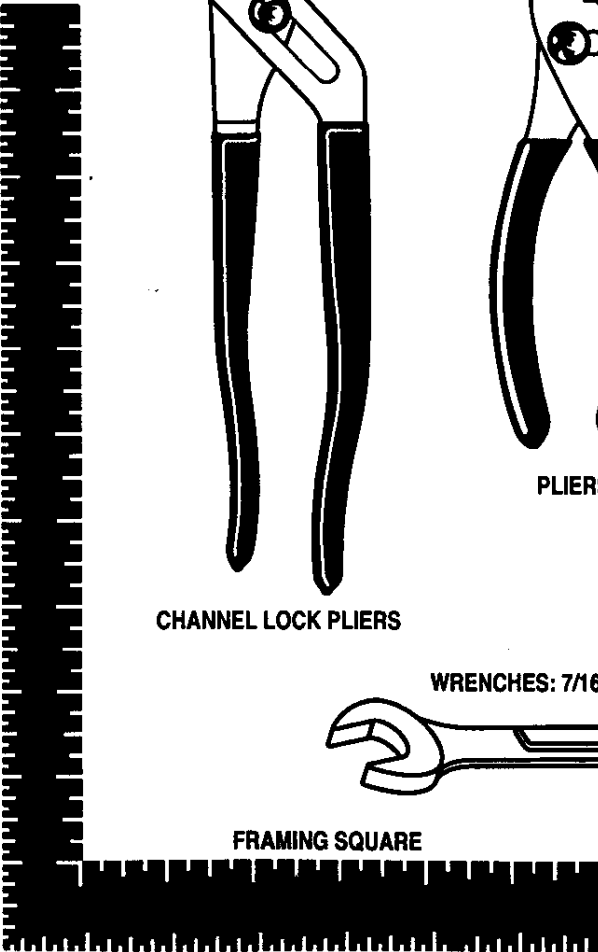
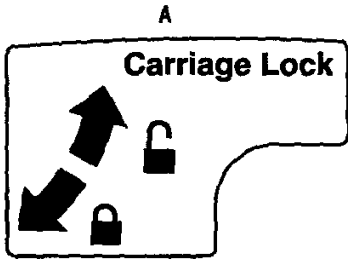
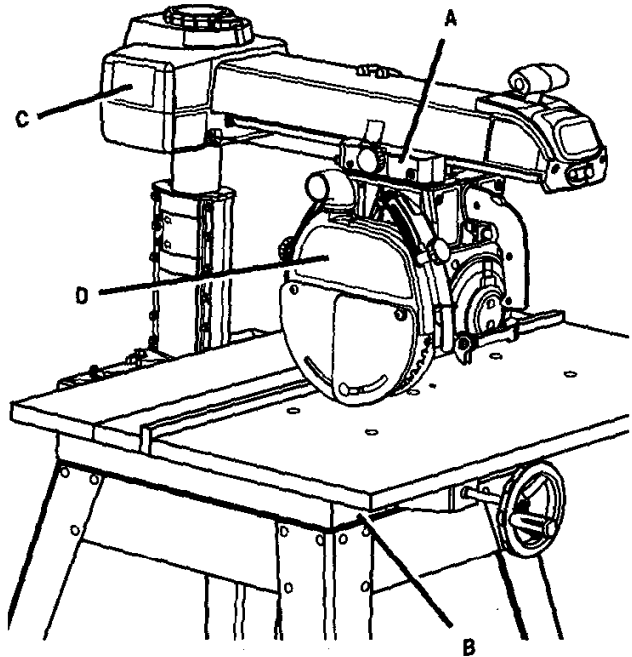



Fig. 7

# LABELS



**B**

**10 inch Radial Arm Saw**  
 3,600 RPM 120 / 240 VOLTS 13 / 6.5 Amp 60 Hz AC ONLY  
 WHEN SERVICING, USE ONLY IDENTICAL CRAFTSMAN  
 REPLACEMENT PARTS.  
 MODEL 315.220381 SER. NO.   
 MADE IN TAIWAN  
 SEARS, ROEBUCK AND CO. 

**Customer Help Line 1-800-932-3188**

**C**

**⚠ WARNING / ADVERTENCIA**

- For your own safety, Read and understand owner's manual before operating saw.
- This tool has more than one connection to the power source.
- To reduce the risk of electrical shock or injury, disconnect all power connections
- When servicing, use only identical replacement parts.
- Para su seguridad, lea y entienda el manual del propietario antes de operar la sierra.

**D**

**CRAFTSMAN®**

**P R O F E S S I O N A L**

**Rip Feed Direction**



**Blade Rotation**



**⚠ WARNING / ADVERTENCIA**

- For your safety, do not feed rip material into saw from this direction.
- Para su seguridad, no introduzca el material que vaya a cortar en la sierra desde esta dirección.

# LABELS

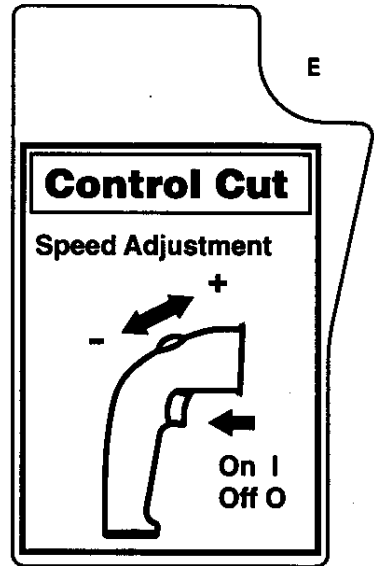
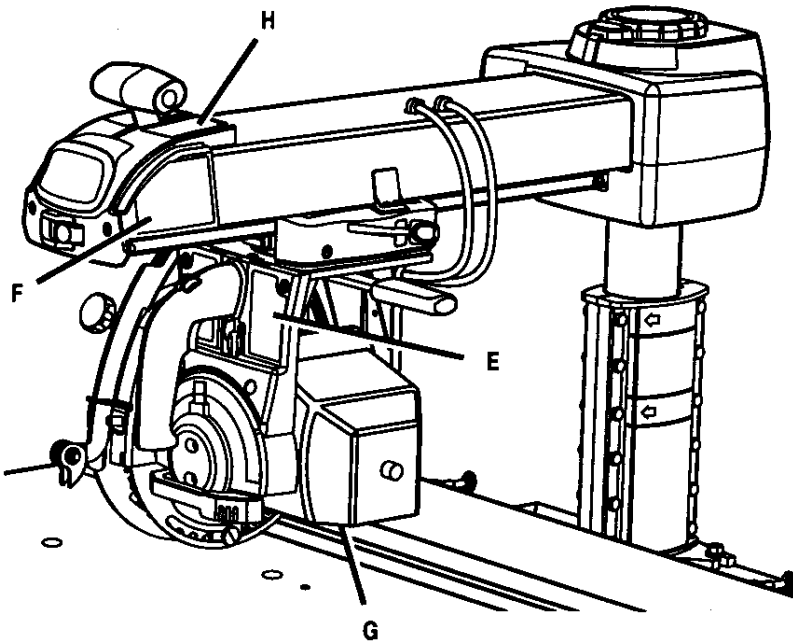

**⚠ WARNING  
ADVERTENCIA**

**F**

- For your safety, read owners manual before operating saw.
- Wear safety goggles.
- Do not perform freehand cuts.
- Return carriage to full rear position after each cross cut.
- See instructions on how to reduce the risk of kickback.
- When ripping, use pushstick when blade is set 2 inches or more from fence.
- When ripping, use pushblock and auxiliary fence when blade is set between 1/2 and 2 inches from fence. Do not make rip cuts narrower than 1/2 inch.
- Keep hands out of path of blade.
- Do not reach around saw blade.
- Turn power off and wait for blade to stop before moving workpiece or changing settings.
- Unplug saw before changing the blade or servicing.
- Para su seguridad, lea y entienda el manual del propietario antes de operar la sierra.

**⚠ WARNING  
ADVERTENCIA**

- Read and understand owners manual before operating saw.
- For your safety, do not use accessories without proper guarding.
- Provide proper workpiece support
- Position cutting tool behind the fence.
- With power off and switch key removed, turn cutting tool by hand to make sure it does not strike guard, fence or any other saw parts.
- Para su seguridad, lea y entienda el manual del propietario antes de operar la sierra.

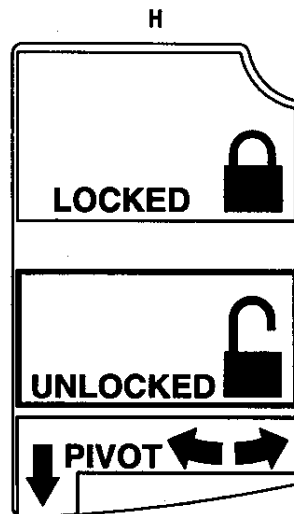

Fig. 8B

## FEATURES

### KNOW YOUR RADIAL SAW

See Figure 9A.

**OVERVIEW** - The main operating components include the column, the arm, and the yoke assembly (yoke, motor, and blade), and their operation is summarized in the paragraph below. Safety features and control functions are given also. Spending a few minutes reviewing the illustrations and features list below and on the following pages to locate these items will make assembly easier.

**METHOD OF OPERATION:** The column at the back of the saw supports the radial arm. The arm can be raised or lowered to change the blade height or swiveled left and right for a miter cut. A yoke fits into a carriage on the arm, which can travel back and forward. The yoke supports the yoke assembly (motor, blade, and blade guard) and can be pivoted so the blade faces right, front, or left. The motor can be rotated to change the blade angle.

Control functions include 1) column height (elevating handwheel), 2) arm angle (arm lock knob), 3) yoke movement on arm (\*carriage lock knob) 4) yoke rotation (\*yoke pivot latch and \*yoke lock handle), and 5) blade bevel (\*bevel index lever and \*bevel lock knob).

Safety features include the control cut device, the removable switch key, and the blade guard assembly. Never operate the saw without ensuring these safety features are in place and functioning correctly.

On a radial saw, "cross cut" means a cut parallel to the arm, and a "rip cut" is perpendicular to the arm. There are several ways to make cuts, depending on the size and material of the workpiece and the end result desired.

Before attempting to use your saw, familiarize yourself with all operating features and safety requirements of your Sears Craftsman Radial Arm Saw.

\*Shown on following pages

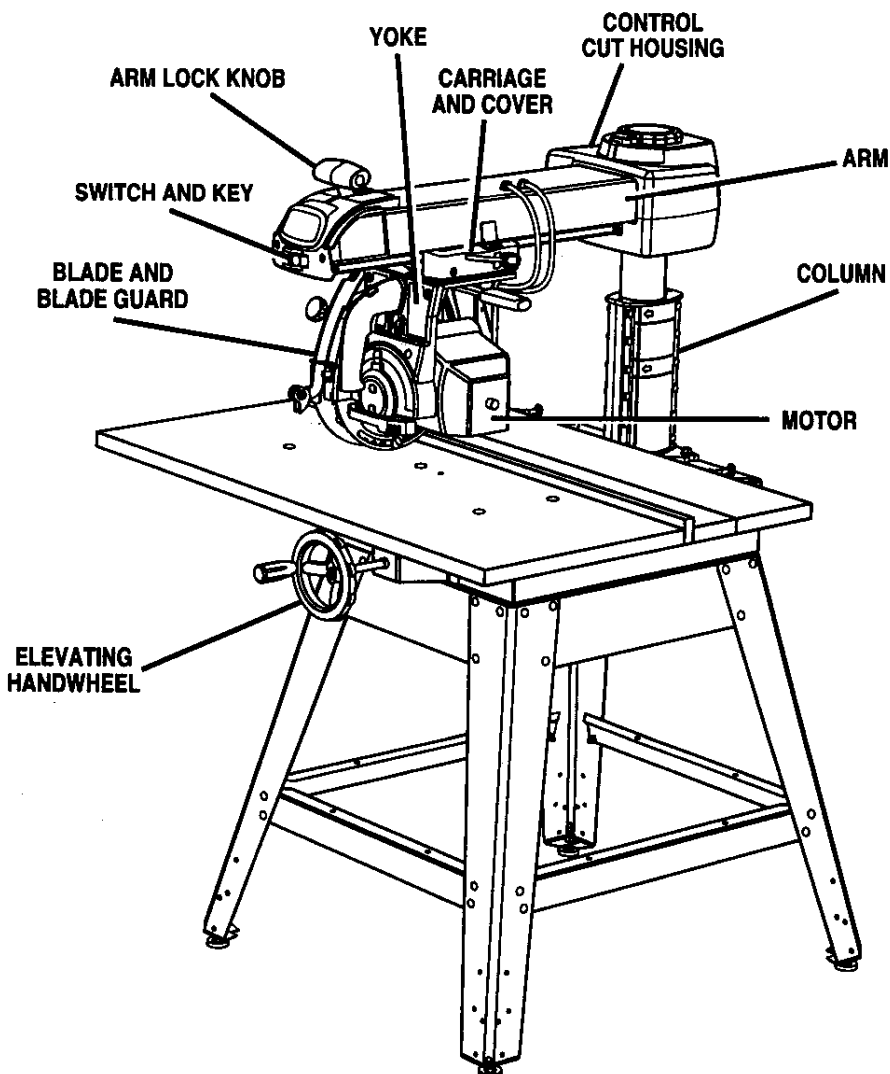

Fig. 9A

## FEATURES

### FEATURES LIST

See Figures 9A-9D.

**ADJUSTABLE TABLES** - A narrow spacer table and wider rear table that can be repositioned or even replaced with different tables. See Figure 9C.

**ANTI-KICKBACK PAWLS** - Toothed pawls that snag the work in case of kickback during rip cuts. (When the blade is parallel to the arm, the pawls are in front of the blade.) Keep the pawls in place to reduce risk of injury. See Figure 9D.

**ARM** - The assembly extending from the column, which supports the yoke, the motor, and the blade. See Figure 9A.

**ARM LOCK KNOB** - Controls arm angle. Use to set the arm to the positive stops at 0°, 45° left, and 45° right and to lock the arm in place. Located on top of arm at front. See Figures 9A and 9B.

**BEVEL INDEX KNOB** - Controls the blade angle between positive stops at 0°, 45°, and 90°. Located behind the handle. See Figure 9B.

**BEVEL INDEX SCALE** - Shows the blade angle for bevel cuts and is located behind the handle. See Figure 9B.

**BEVEL LOCK LEVER** - Sets and locks blade angle. It is located below the handle. See Figure 9B.

**BLADE** - For maximum performance, use the Craftsman 40-tooth, 10 in. carbide-tipped blade provided with your saw. It is a high-quality combination blade suitable for ripping and crosscut operations. Blades recommended for other operations are listed in the *Accessory* section of this manual. The blade is powered by the main motor and turned off by the switch. See Figure 9D.

**WARNING:** Use only blades rated for at least 5,000 rpm and recommended for use on this saw. Check with your nearest Sears retail store.

**BLADE GUARD ASSEMBLY** - Protective unit over the blade, with a riving knife, anti-kickback pawls, an upper blade guard, a lower outer blade guard, and a lower inner blade guard. Always keep each item in place unless specifically instructed to move it. See Figures 9A and 9D.

**BLADE GUARD CLAMP SCREW** - Secures the blade guard to the motor. Located between the blade and the motor. See Figure 9D.

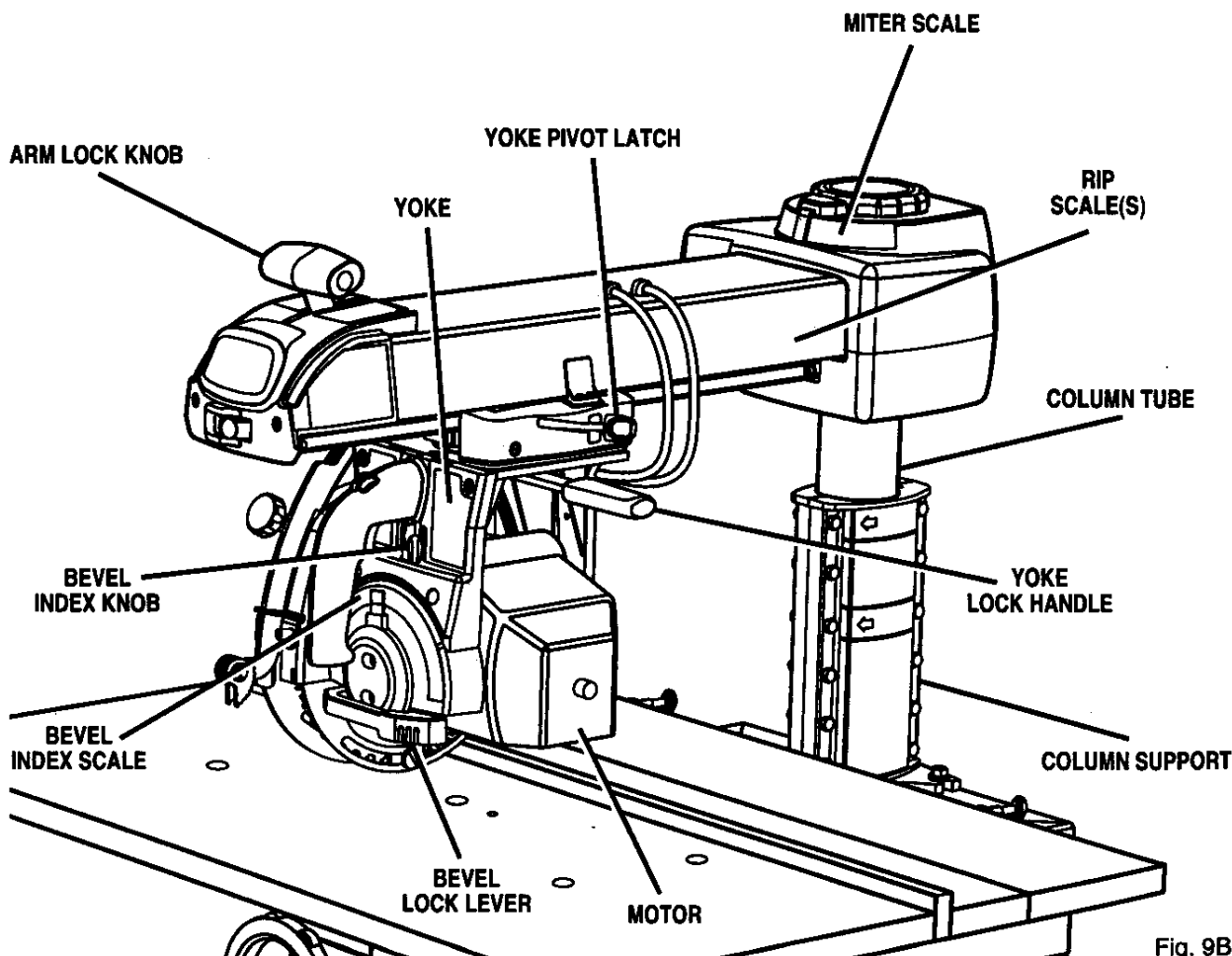

Fig. 9B

## FEATURES

**CARRIAGE** - Slides along track under arm and supports yoke. Contained in two carriage covers, one on each side of the arm. *See Figure 9C.*

**CARRIAGE LOCK KNOB** - Controls whether the carriage is locked or can travel. Located on the left side of the arm on the carriage cover. *See Figure 9C.*

**COLUMN** - Upright housing at the back of the saw, consisting of a column support and a column tube. The column tube can be raised or lowered with the elevating handwheel at the front of the saw. *See Figures 9A and 9B.*

**CONTROL CUT DEVICE** - Limits carriage speed to prevent climb, using a cable from the carriage to the column. Has a separate motor on left side, which is activated by the switch trigger in the handle. The cable returns the carriage to the column when the motor is not activated. Speed is adjusted with a thumbwheel on the handle. It runs on a separate 120V AC single voltage circuit. *See Figure 9C.*

**⚠ WARNING:** When connecting only one of the cords, squeeze the switch trigger in the handle. If the main motor cord alone is connected, the switch trigger in the handle will not operate the control cut device. The carriage cannot be advanced without power to the control cut device.

**DUAL VOLTAGE** - If needed, your main power source may be rewired by a qualified electrician to provide a 240V AC circuit. *See the Electrical section.*

**DUST GUIDE** - Directs sawdust, created from the cut being made, in the direction you set. Located at the rear of the upper blade guard. *See Figure 9D.*

**ELEVATING HANDWHEEL** - The handwheel below the worktable (in front) that changes the height of the arm and the blade. *See Figure 9C.*

**FENCE** - Removable guide for work, which extends across width of table. *See Figure 9C.*

**FRONT TABLE** - Fixed portion of the worktable that supports the work. *See Figure 9C.*

**HANDLE** - Used to pull the yoke assembly. Mounted on the yoke to the right of the blade. *See Figure 9C.*

**HOLD DOWN** - A metal guard to control workpiece climb during rip cuts. When blade parallels arm, hold down is over the back of the blade. *See Figure 9D.*

**HOLD DOWN KNOB** - Controls placement of the hold down and locks it in place. *See Figure 9D.*

**MITER SCALE** - Shows the miter angle setting of the arm. *See Figure 9B.*

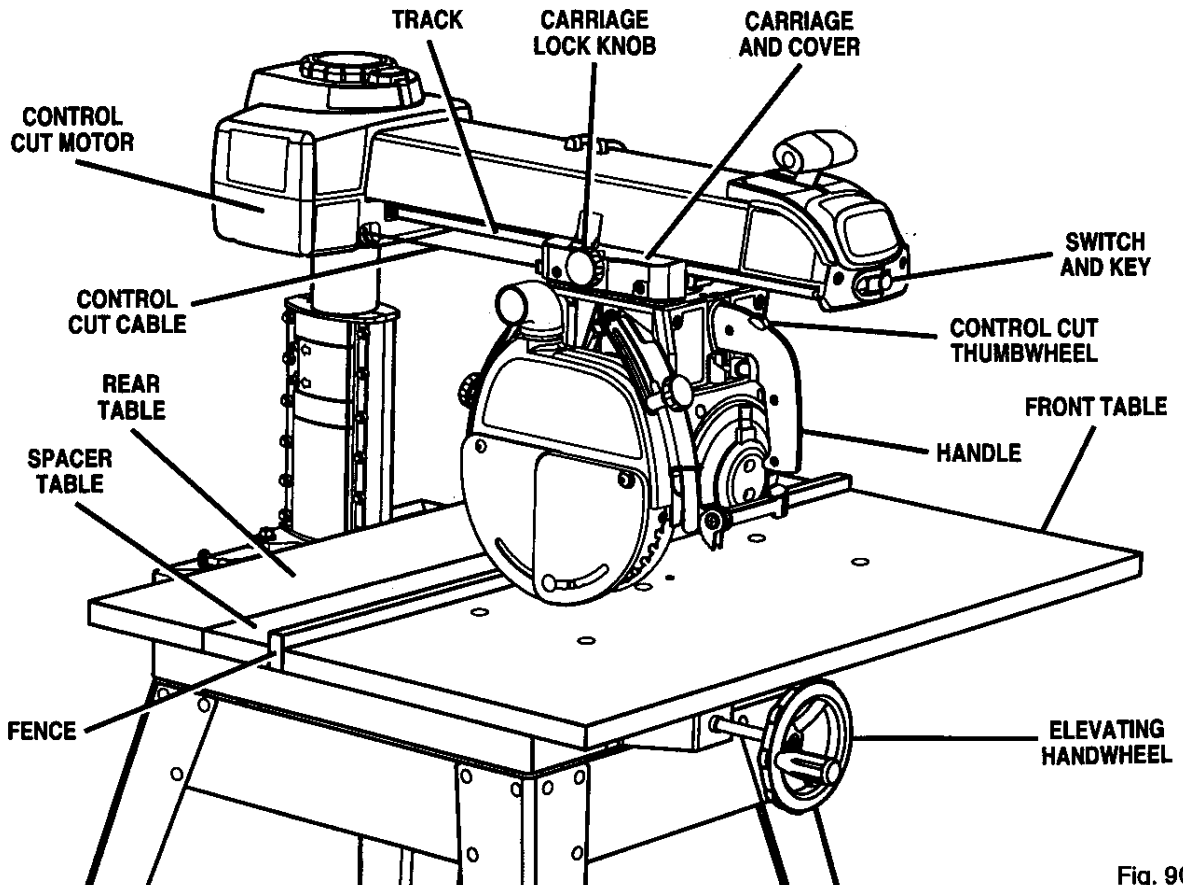

Fig. 9C

## FEATURES

**MOTOR (13/6.5 AMP)** - Powers the blade and is controlled by the switch and key at the front of the arm. The powerful induction motor has a capacitor start. It is mounted in the yoke and rotated with the bevel index knob and bevel lock lever. *See Figure 9B.*

**RIP SCALES** - Show the distance from the fence to the blade. (In-rip scales are on the right side of the arm, and out-rip scales are on the left side.) Upper scales show the distance with the fence beside the front table. Lower scales show the distance with the fence in farthest back position. *See Figure 9B.*

**RIVING KNIFE OR SPREADER** - Located directly in front of the blade and beside the anti-kickback pawls, the riving knife keeps cut edges from binding during rip cuts. *See Figure 9D.*

**RIVING KNIFE BRACKET** - Allows adjustment of the riving knife. Located midway along the riving knife. *See Figure 9D.*

**RIVING KNIFE KNOB** - Adjusts the riving knife and locks both the pawls and the riving knife in place. Located toward the top and front of the blade guard. *See Figure 9D.*

**SWITCH TRIGGER** - Used to power the control cut device to allow yoke assembly to be pulled forward. Mounted in the handle. *See Figure 9D.*

**SWITCH WITH KEY** - Powers the blade motor. Placed on the front of the arm for easy access. To lock the switch once it has been pressed to **OFF**, remove the yellow key. Place the key in a location that is inaccessible to children and others not qualified to use the tool. *See Figures 9A and 9C.*

**YOKE** - Supports the blade and motor. Can be pivoted to index the blade between rip and cross cuts. Located between the carriage and the motor. *See Figure 9B.*

**YOKE PIVOT LATCH** - Indexes the yoke (after it is released) to position the blade to face right (out-rip cut), front (cross cut), or left (in-rip cut). Located on the right carriage cover. *See Figure 9B.*

**YOKE LOCK HANDLE** - Releases the yoke to allow indexing for rip cut or cross cut. Located below the yoke, on the right. *See Figure 9B.*

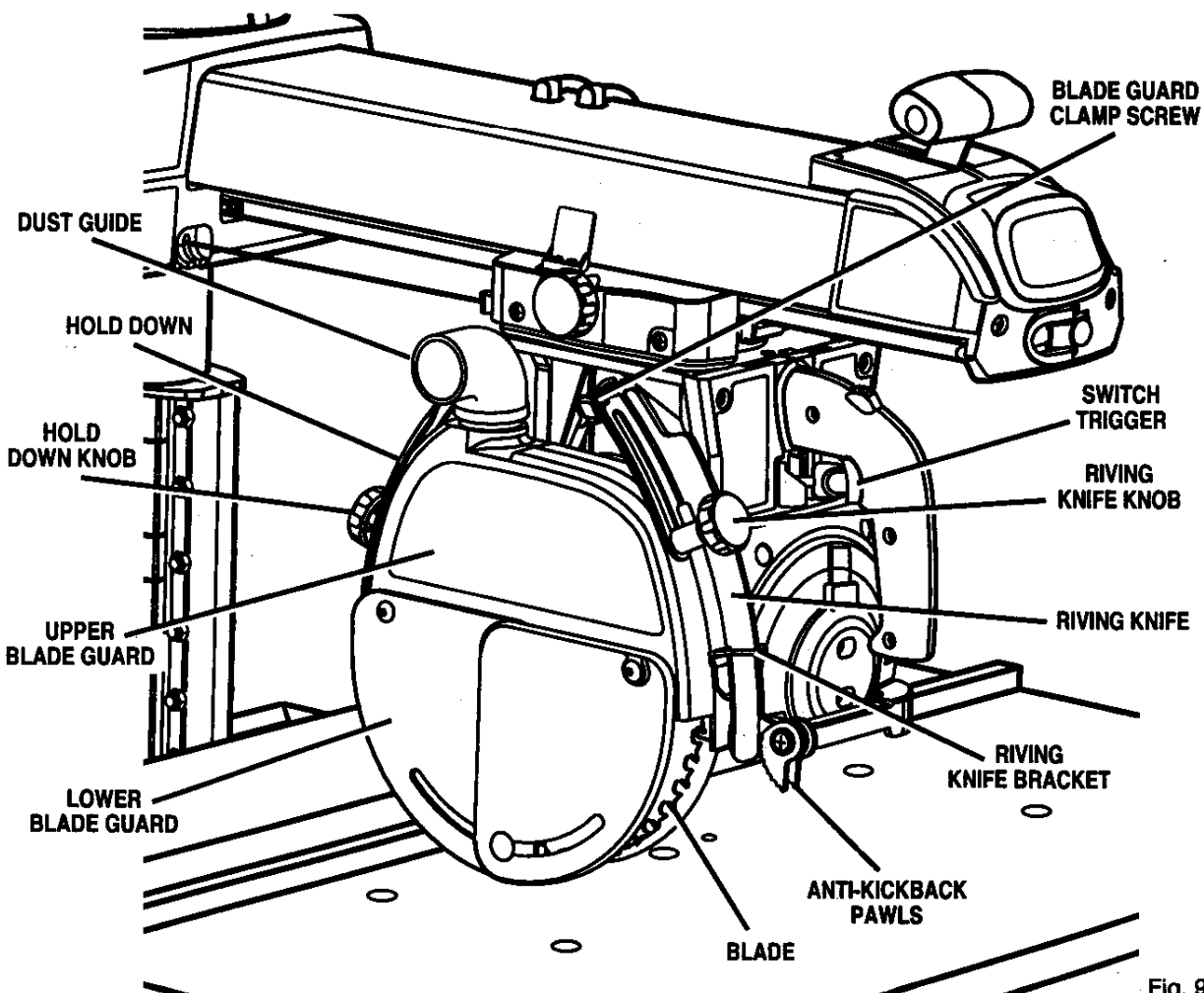

Fig. 9D

# ASSEMBLY

Assembly is best done in the area where the saw will be used. When you remove the saw and hardware from the packing materials, carefully check the items with the Loose Parts list. If you are unsure about the description of any part, refer to their illustrations. For your convenience, all fasteners have been drawn actual size. If any parts are missing, delay assembling until you have obtained the missing part(s).

Your radial arm saw is capable of a wide variety of operations, and thus requires a number of initial setup adjustments. However, once the saw is set up, you can check your saw in about ten minutes and correct any misalignment with the procedures in the *Adjustment* section.

**CAUTION:** Perform all the procedures in both the *Assembly* and *Adjustments* sections before using the saw. Run a check on your saw frequently, referring to the *Adjustments* section. Failure to perform the adjustments in the initial set up or on a frequent basis can result in poor performance or machine damage.

## ASSEMBLING LEG STAND

See Figures 10A - 10C.

- Take the following hardware from the hardware bags in the leg stand carton:
  - 40 truss head screws (1/4-20 x 5/8 in.)
  - 40 star washers (1/4 in.)
  - 40 hex nuts (1/4-20)
- Take the following hardware from the remaining hardware bags in the leg stand carton:
  - 4 leveling feet
  - 8 large hex nuts (3/8-16)
- Obtain four legs and eight braces from the leg stand carton. See the *Loose Parts* section.

- Place a 3/8-16 hex nut on each leveling foot and insert leveling feet into the bottom of the legs. Cap with remaining 3/8-16 hex nuts but only finger tighten. See Figure 10A.
- Place a short upper brace inside two of the legs (wide end of legs up) and align the three holes in the brace with the holes in the legs.
- Insert the screws. Add the star washers and 1/4-20 hex nuts. Finger tighten.
- Install a short lower brace on the legs. See Figure 10A.
- Repeat for the other end assembly.
- Connect the leg sets with a long upper brace. Add the hardware and finger tighten. Repeat for the other side brace, then install the long lower braces. See Figure 10B.
- Tighten all screws, washers, and nuts with a 7/16 in. wrench and as needed a #2 phillips screwdriver.
- Move the leg stand to the desired location. Using a level, adjust the leveling feet by raising or lowering the bolts with a 9/16 in. wrench.
- When the leg stand is level, securely tighten all four nuts with the wrench.
- Your leg stand is now completely assembled and ready for use. See Figure 10C.

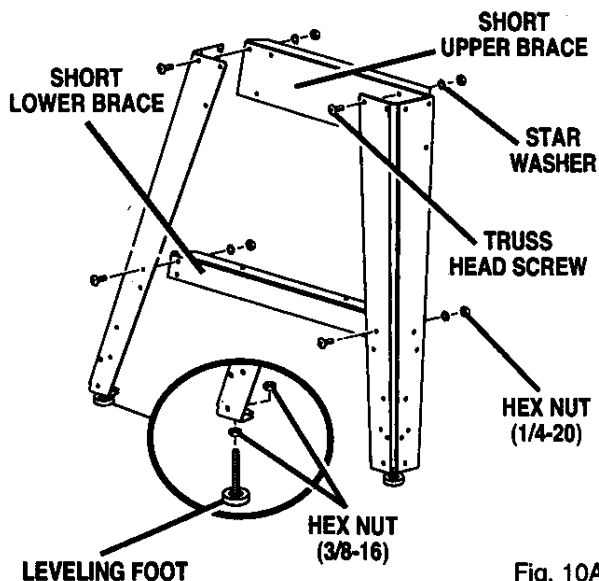

Fig. 10A

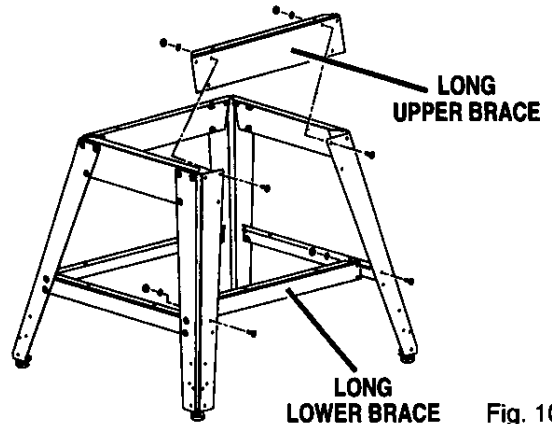

Fig. 10B

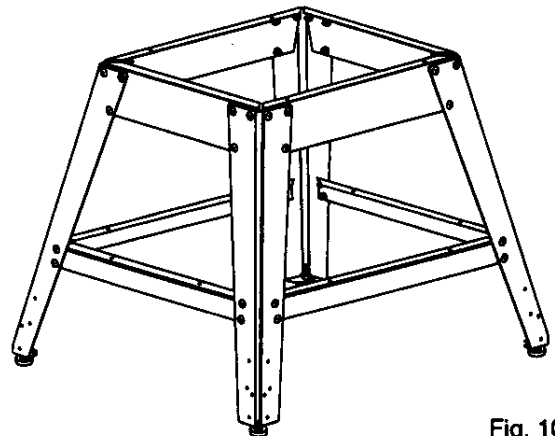

Fig. 10C

# ASSEMBLY

## MOUNTING SAW TO LEG STAND

See Figure 11.

- ⚠ **WARNING:** Firmly bolt the saw to the leg stand to keep the saw from tipping, walking, or sliding.
- Locate the following hardware from a small hardware bag:
  - 4 hex bolts (5/16-18 x 5/8 in.)
  - 4 lockwashers (5/16 in.)
  - 8 flat washers (11/32 in.)
  - 4 hex nuts (5/16-18)
- Place the saw on top of the leg stand so the holes in the saw base line up with the holes on top of the leg stand braces.
- Put a washer on a screw, and put the screw and washer into the hole in the saw base. Cap with another washer, then a lockwasher and a hex nut. Hand tighten the set.
- Install the other three sets and securely tighten all four sets with a 1/2 in. wrench.

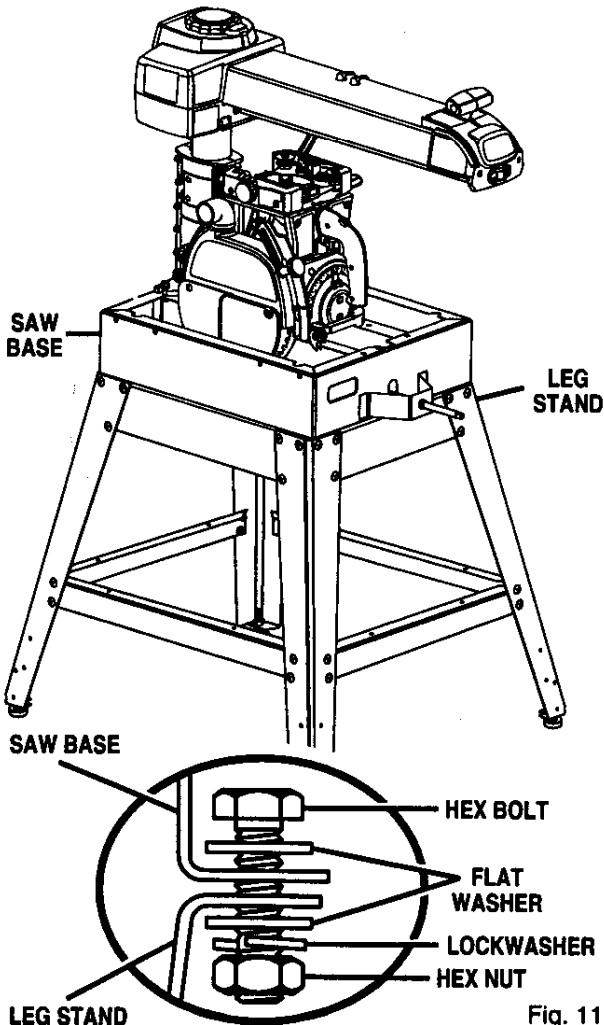

Fig. 11

## ATTACHING ELEVATING HANDWHEEL

See Figure 12.

- ⚠ **WARNING:** Be sure the main power cord of your saw is unplugged. Ignoring this precaution could result in serious injury. Do not perform the following steps unless the saw is unplugged.

The elevating handwheel adjusts the height of the radial arm and the blade.

- Take the handwheel, star washer, and screw (10-24 x 5/8 in. Soc. Hd.) from the hardware bag.
- Place the handwheel on the end of the elevating shaft, which extends from the front of the saw base.
- Place the star washer on the screw and thread screw into the end of the shaft.
- Securely tighten the screw with a 5/32 in. hex key.
- Raise or lower the arm by turning the handwheel.

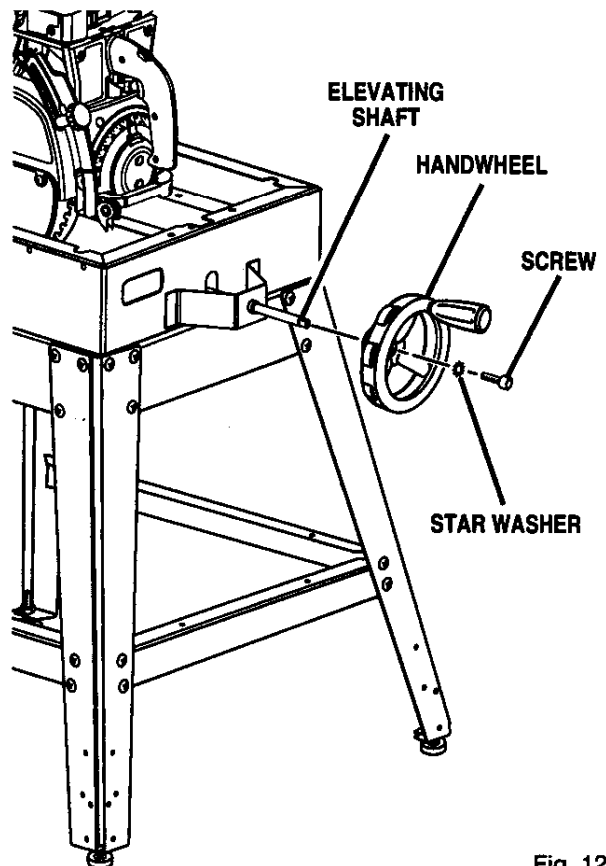

Fig. 12

## ASSEMBLY

### INSTALLING THE YOKE ASSEMBLY

See Figures 13A - 13C.

The yoke rides in the carriage below the arm and supports the motor, the blade guard, and the blade. Install the yoke assembly from the front of the arm.

- Remove the carriage stop screw and lockwasher from below the front of the arm with a 1/4 in. hex key. See Figure 13A.

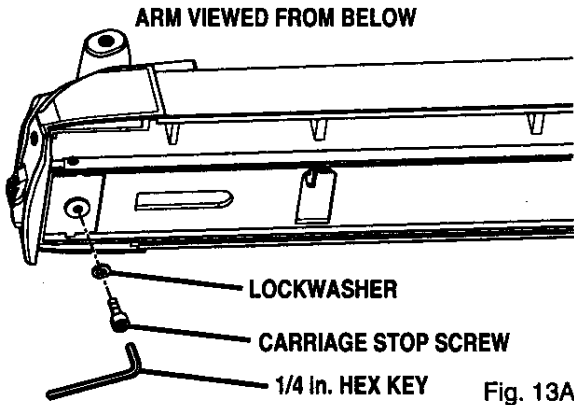

- Remove the arm cap screws and arm cap from the front of the arm with a phillips screwdriver. See Figure 13B.

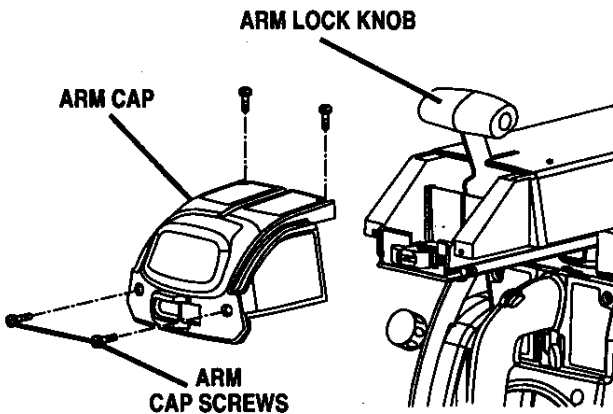

- Remove and discard the two motor setscrews in the bottom of the motor. They are for shipping purposes only.
- Using the elevating handwheel, raise the arm 3 inches and remove the packing material.
- Lock the arm with the arm lock knob, located on top of the front of the arm, so the arm doesn't swing while you are mounting the yoke assembly.
- Pick up the yoke assembly and carefully slip it onto the carriage track below the arm. Keep it parallel with the arm so bearings slide in smoothly. See Figure 13C.

FOR CLARITY, CARRIAGE COVERS AND CARRIAGE LOCK KNOB ARE NOT SHOWN IN ILLUSTRATION

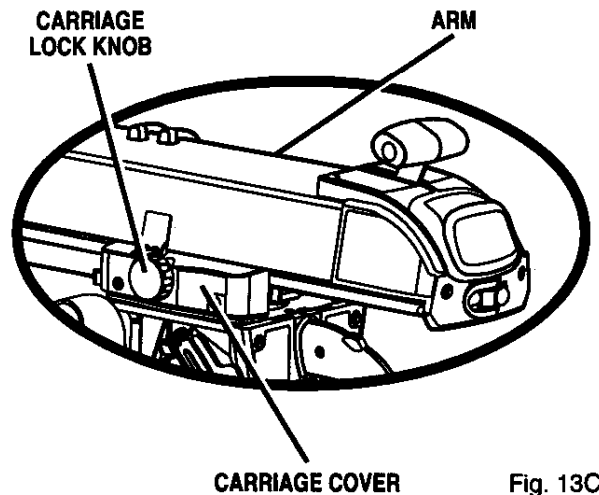
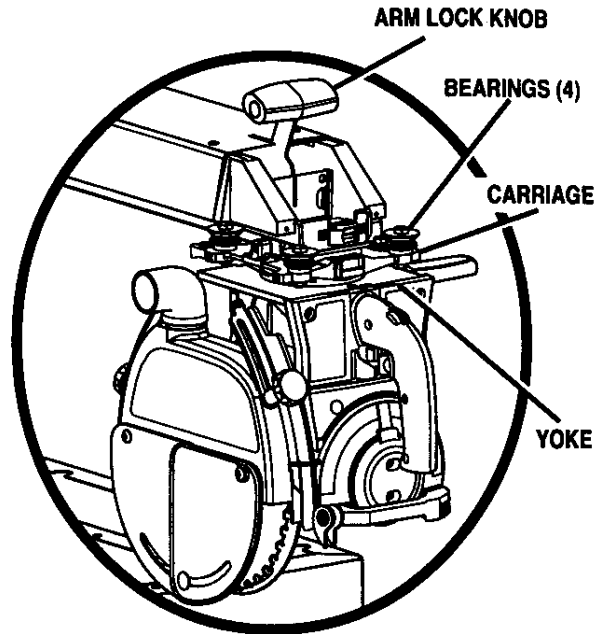

- Reinstall the carriage stop screw, the lockwasher, arm cap, and arm cap screws. Tighten all screws securely.
- ▲ **WARNING:** Once the yoke assembly is on the carriage track, reinstall the arm cap, the arm cap screws, the carriage stop screw, and the lockwasher. Do not risk serious injury or damage to the saw by failing to replace these parts.
- Tighten the carriage lock knob, on the carriage cover on the left of the arm, to lock the yoke assembly in place.

## ASSEMBLY

### REMOVING THE BLADE

See Figure 14.

Remove the blade and blade guard assembly during setup for safety and better access. The blade guard includes an upper blade guard, an outer lower guard, and an inner lower guard. The lower inner guard consists of two overlapping slotted metal strips. The strips are held together with a retaining screw and a nut. Locate these items before beginning the procedure.

**⚠ WARNING:** To prevent accidental contact with the blade that could result in injury, remove the blade and blade guard before making setups involving the blade arbor and work stand. Use the blade wrenches provided with your saw.

- Remove the retaining screw and nut at the bottom of the lower inner blade guard.
- Loosen the guard clamp screw, a long thumbscrew between the blade guard and the motor.
- Rotate and lift the guard assembly up and over the blade, then remove it.
- Hold the blade arbor (motor shaft) with one of the two blade wrenches provided. Put the other blade wrench on the blade nut and turn it clockwise (down), since the blade arbor has left hand threads.
- Remove the blade nut, outer blade washer, saw blade, and inner blade washer. Set these items aside until all the tables have been installed and the front table is level.

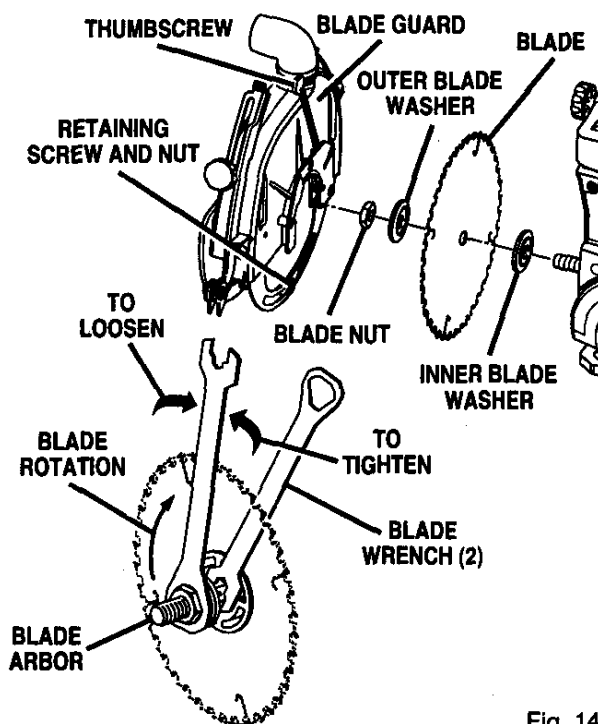

Fig. 14

25

### ATTACHING TABLE SUPPORTS

See Figure 15.

The table supports are a base for the three wooden table sections and fence.

- Locate the two table supports and the following hardware:
  - 4 square head bolts (5/16-18 x 3/4 in.)
  - 4 lockwashers (5/16 in.)
  - 4 hex nuts (5/16-18)
  - 4 flat washers (5/16 in.)
- Attach the supports to the side of the saw base. There are holes in both sides of each support. The long side of each support (with the slotted holes) fits against the saw base.
- Use two square head bolts per support, inserted from within the saw base outward.
- Place a flat washer, a lock washer, and a hex nut on the end of each screw.
- Position table supports so that bolts are approximately centered in slotted holes.
- Finger tighten or snug with a 1/2 in. wrench only at this time. Final adjustments will be made later in *Leveling The Table Supports* section.

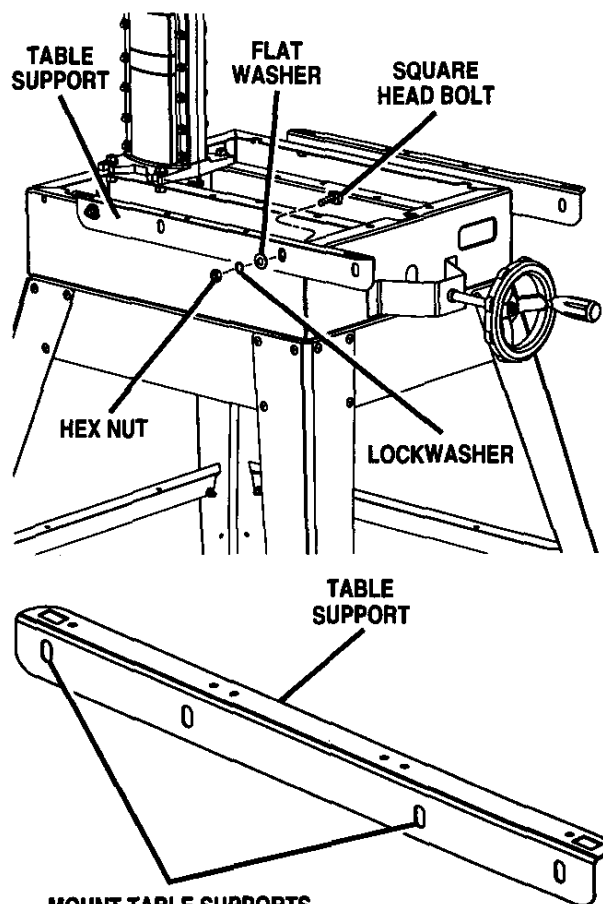

MOUNT TABLE SUPPORTS  
USING THESE HOLE LOCATIONS

Fig. 15

CRAFTSMAN® RADIAL SAW 315.220381

## ASSEMBLY

### SETTING THE ARM LOCK KNOB

See Figure 16.

It may be possible to move the arm when locked, if the arm lock knob is too loose. If the arm does not move freely when unlocked, the arm lock knob may be too tight. Use this procedure to check and set the arm lock knob by turning the arm lock wheel (under the carriage arm).

- To release the arm lock knob, located on top of the arm at the front, pull the arm lock knob forward until the spring is compressed.
- While holding the arm lock knob forward, swing the arm 30° to the left or the right, referring to the miter scale on top of the column.
- Lock the arm in place by pushing the arm lock knob back until it pops in the locked position.
- Apply a reasonable amount of pressure on the arm. The arm can be forced but if it moves easily, it needs adjustment.
- Locate the arm lock wheel.
- Release the arm lock knob and turn the lock wheel clockwise to tighten or counterclockwise to loosen.
- Repeat above steps until the arm movement is minimized when locked.

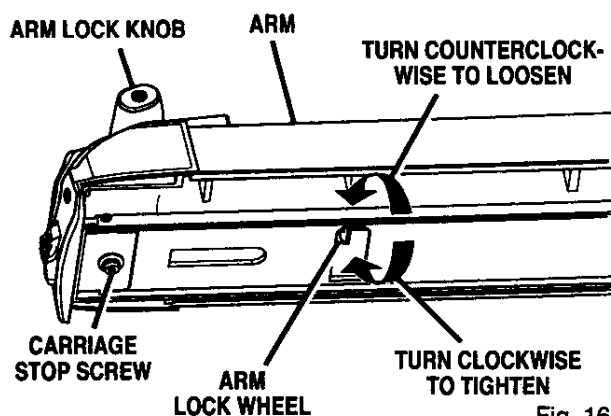

Fig. 16

### SETTING THE YOKE CLAMP

See Figures 17A and 17B.

The yoke clamp keeps the yoke from rotating on the carriage when you want the saw blade to be stationary. Use this procedure to check and set the yoke clamp.

- Release the yoke lock handle (below the arm on the right side) so the motor can be rotated.
- Swivel the motor slightly. It should be at an angle in between one of the preset positive stop angles.

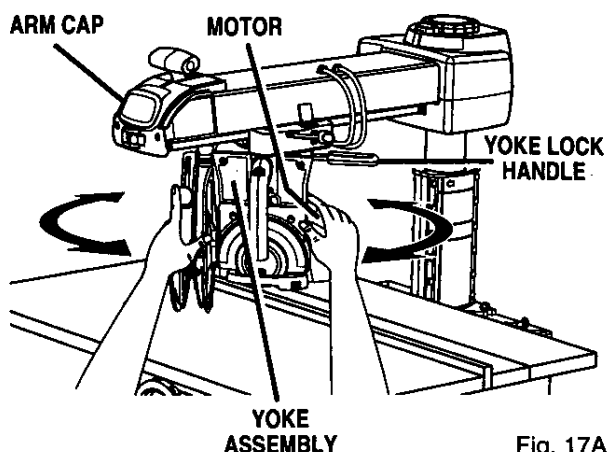

Fig. 17A

- Lock the yoke lock handle. Grasp the motor with both hands and apply reasonable pressure to see if it slips. If it moves, reset the yoke lock handle as follows.
- Remove the arm cap screws and arm cap at the front of the arm with a phillips screwdriver. See Figure 13B.
- Remove the carriage stop screw and lockwasher with a 1/4 in. hex key. Carefully slide the yoke assembly forward and off the carriage.
- Place the yoke assembly in a spot where it will be secure as you work on the top of the yoke.
- Release the yoke lock handle. Tighten the center nut with a 15/16 in. wrench until the lock handle is centered between the two legs of the yoke.
- Carefully replace the yoke assembly on the carriage arm track. Slide it back about halfway.
- Replace the carriage stop screw and lockwasher, followed by the arm cap and arm cap screws.
- Lock and test the yoke again. If it can be moved, repeat the procedure until it is secure.

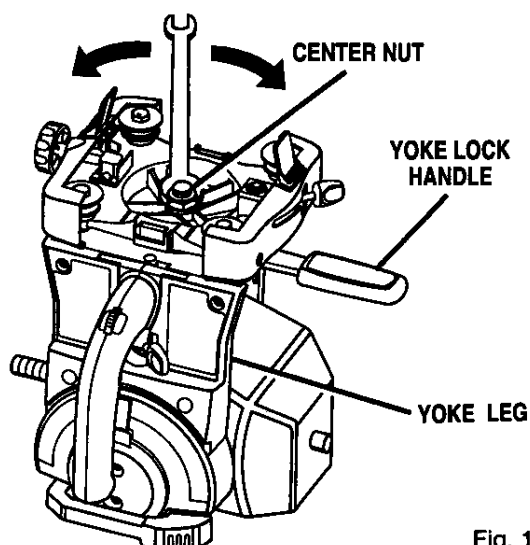

Fig. 17B

## ASSEMBLY

### SETTING THE BEVEL LOCK LEVER

See Figures 18A – 18C.

The bevel lock lever locks the blade at desired angles other than the preset positive stop angles. The bevel lock lever is preset at the factory but may need readjustment after shipping or extended use. Check for overtightness or looseness and make any necessary adjustments as follows:

The bevel lock lever is located on the front of the yoke assembly, near the bottom. It is attached to a clamp bolt that controls the amount of tightness.

- Pull the bevel lock lever forward to unlock it. Use the bevel index knob (just under the handle) to rotate the motor approximately 30°. Lock the bevel lock lever.
- If the bevel lock lever is difficult to lock, the clamp bolt needs to be loosened. If the motor can be forced out of position, the clamp bolt needs to be tightened.
- Remove the socket screw (under the bevel lock lever) and star washer with a 1/8 in. hex key.
- Use the bevel lock handle as a wrench to tighten or loosen the clamp bolt. The clamp bolt has a right-handed thread. Tighten it left to right.
- When the bolt is correctly set, remove the bevel lock lever from the clamp bolt and place it roughly parallel to the yoke assembly.
- Replace the socket screw and star washer. Recheck the tightness of the bevel lock lever. Repeat the steps above until the motor is secure when locked, and the bevel lock lever fits squarely against the yoke assembly.

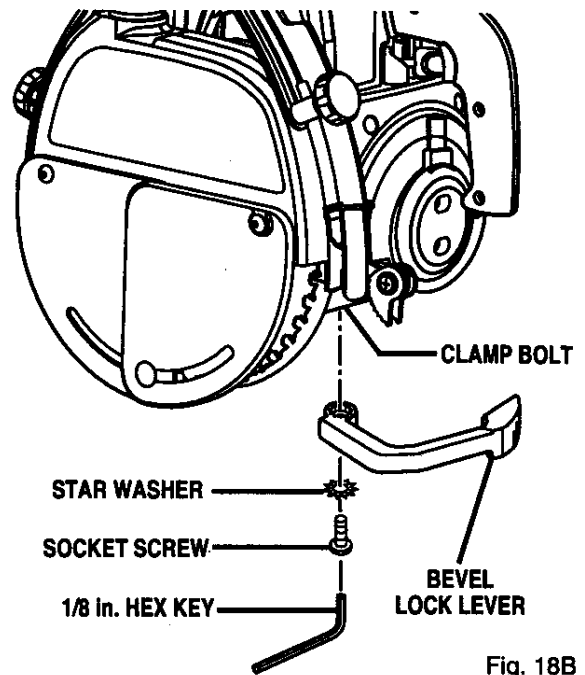

Fig. 18B

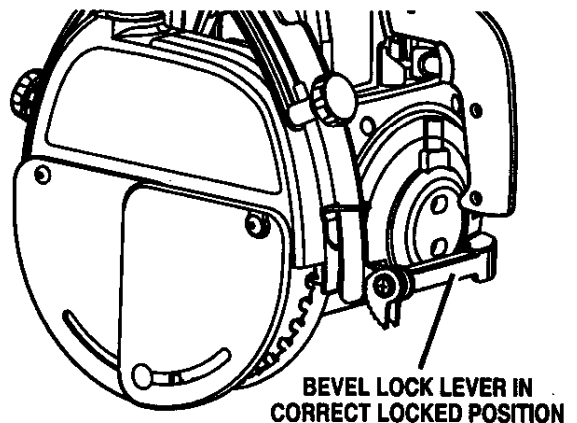
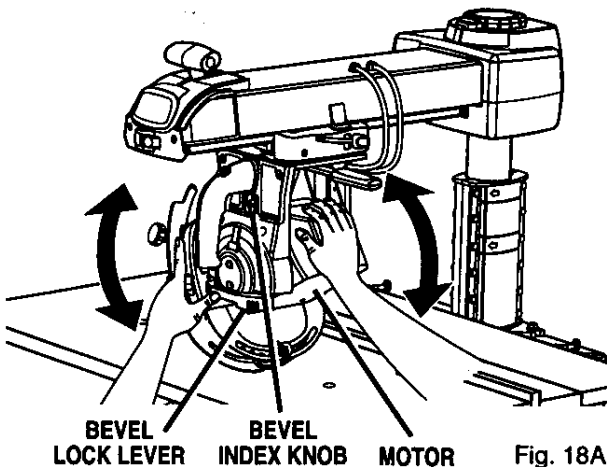

Fig. 18C



## ASSEMBLY

### TIGHTENING THE ARM AND COLUMN

See Figure 19.

There should be no play, vertical or horizontal, in the arm relative to the column. If you can move the arm up, down or sideways when the arm lock is unlocked, use the following steps to tighten the arm.

**Note:** The arm should pivot only when the arm lock knob is unlocked and pulled forward to compress the spring.

- Using a phillips screwdriver, remove the rear cover screws (2) and rear cover from the back of the arm. This uncovers the bolts on the column.
- Tighten the top two bolts evenly until the arm is firm and there is no vertical or horizontal movement.
- Also check the two bottom hex nuts. It is not necessary to tighten them as tight as the upper bolts. However they should be tightened even and snug.
- Replace the rear cover and rear cover screws.
- Tighten screws securely.

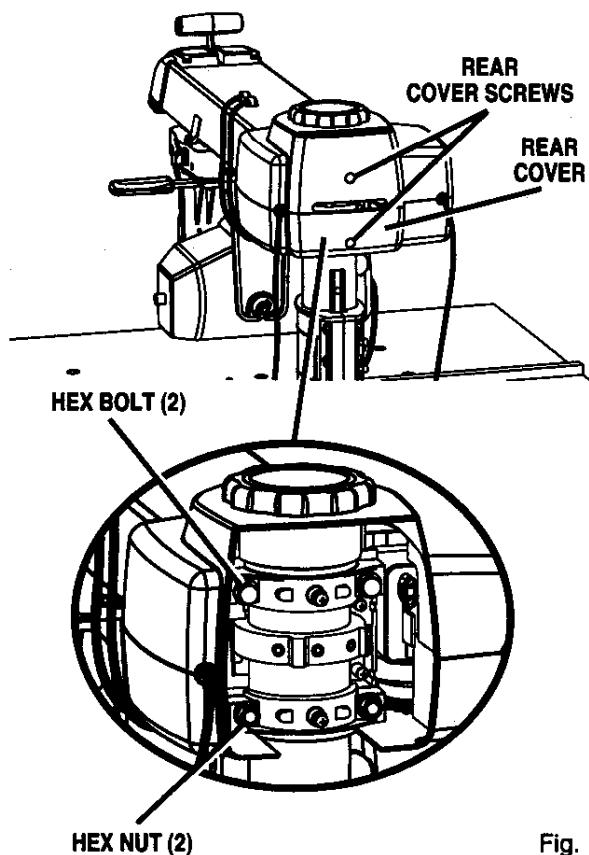

Fig. 19

### ADJUSTING THE COLUMN TUBE

See Figures 20A - 20D.

The purpose of this procedure is to check whether the inner column tube is snug in the housing and to remove any looseness. Looseness could result in a poor cut or difficulty in elevating the carriage. The column tube is the upper portion of the column and extends from the column support.

**Note:** It is *critical* to remove all looseness with this procedure. If this procedure is not done correctly, following adjustments will be wrong and could result in machine damage.

This procedure checks both the elevating action and the rotating action. If a check does not show looseness, do not perform the adjustment.

- If the arm is not at 0° (straight forward), release the arm lock knob, set the arm, and re-lock the arm lock knob.
- *Elevation check:* To check the elevation movement, place your hand under the front of the radial arm. Press upward on the radial arm. There should be minimal play between the column tube and the column support. The whole assembly should move as one. See Figure 20A.

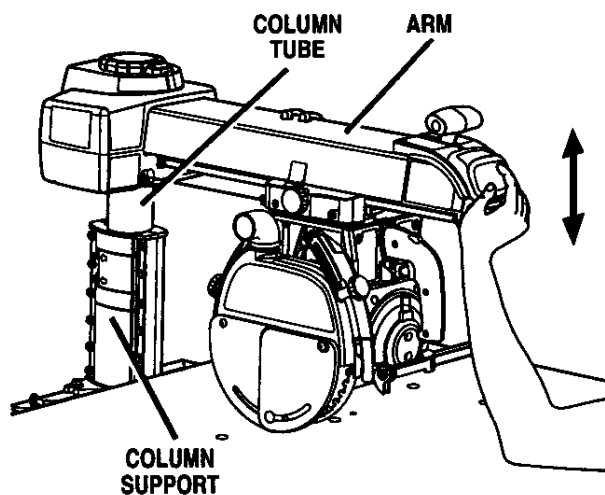
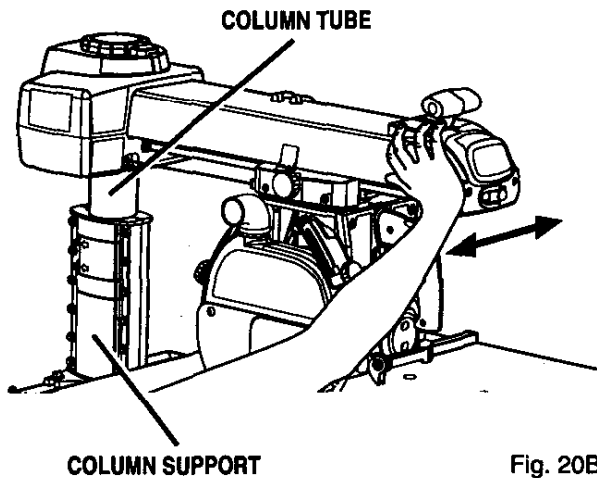

Fig. 20A

## ASSEMBLY

- **Rotation check:** To check the rotation, hold the front of the arm with one hand and grasp the top of the column support with the other. Press the arm to the side. If there is play between the column support and the column tube, it needs to be adjusted. See Figure 20B.



- **Elevation Adjustment:** If the elevation check did not show any play between the column tube and the support, go to the rotation adjustment. Otherwise, raise and lower the arm with the elevating handwheel. Tighten the black screws on the right side of the column support by 1/16th to 1/8th of a turn. Tighten the two silver screws on the left side slightly more. You will need two 1/2 in. wrenches or sockets. Turn the elevating handwheel again. If the column tube binds, loosen the silver and black screws and turn the handwheel again. See Figure 20C.
- When the elevation is smooth, check for looseness again by pressing upward on the front of the arm. Repeat the previous step until elevation is smooth with no play between the column tube and the column support.

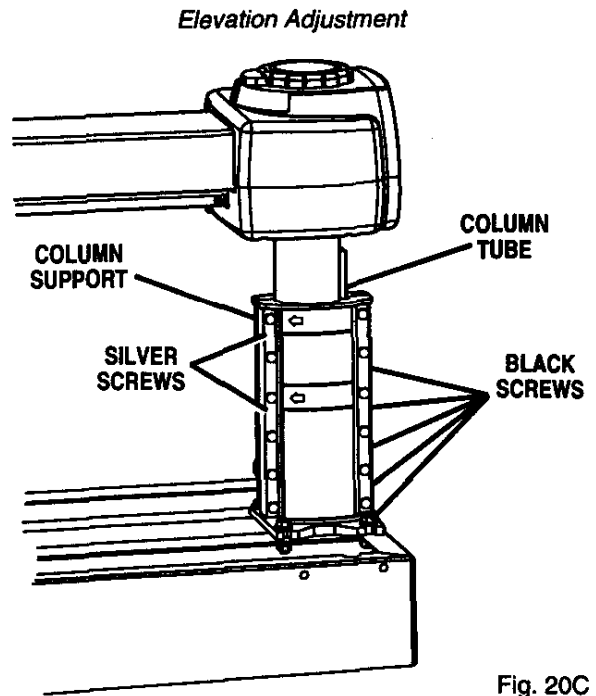

- **Rotation Adjustment:** Using a 3/16 in. hex key, slightly tighten the two cap screws at the back of the column support (left side) until no play shows between the radial arm and the column. The cap screws are indicated by arrows. See Figure 20D.
- Recheck the rotation by holding the front of the arm, grasping the top of the column support with the other, and pressing the arm to the side.

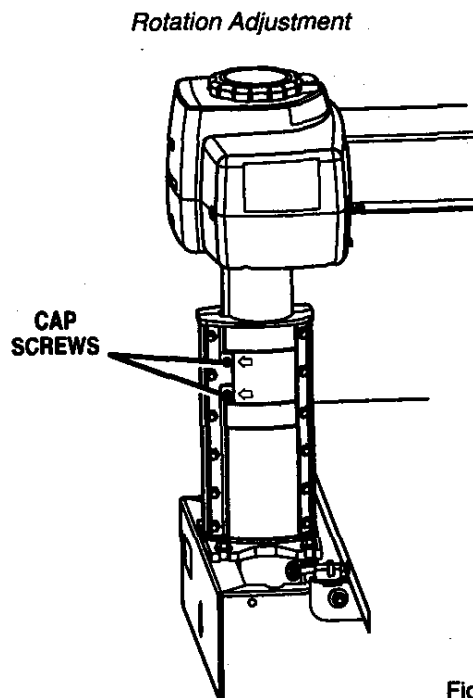

## ASSEMBLY

### ADJUSTING THE CARRIAGE BEARINGS

See Figures 21A and 21B.

Loose carriage bearings permit the blade to wander slightly while cutting, which will result in a poor cut and more wear and tear on the saw. Use the following steps to check for tightness and to then adjust the bearings if needed.

- On the left side of the arm, remove the carriage lock knob, the carriage cover screws, and the carriage cover.
- With one hand, grip the front bearing hard to keep it still, and pull the carriage forward with the other hand. The bearing should turn. If it stays still as the carriage is moved, it needs to be adjusted.

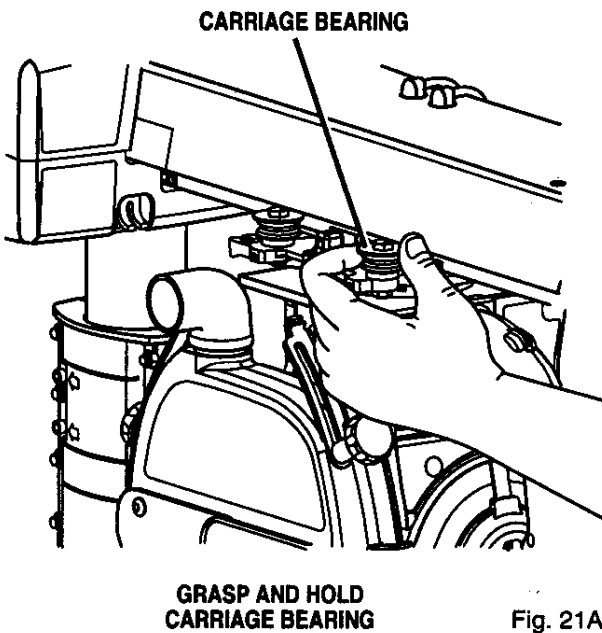

- Use a 9/16 in. wrench to hold the eccentric screw (top of bearing) and a 1/2 in. wrench to loosen the nut below the bearing.
- Turn the eccentric screw a partial turn as needed to tighten the bearing.
- Retighten the nut and repeat the second step to test the tightness. Adjust it so the bearing turns even against resistance when the carriage is moved - but not so much that the carriage is difficult to move and return it to its rear position.
- Repeat for the left rear bearing.

**Note:** Adjust bearings on the left side only. Bearings on the right side do not adjust.

- Replace the carriage cover, carriage cover screws, and carriage lock knob.

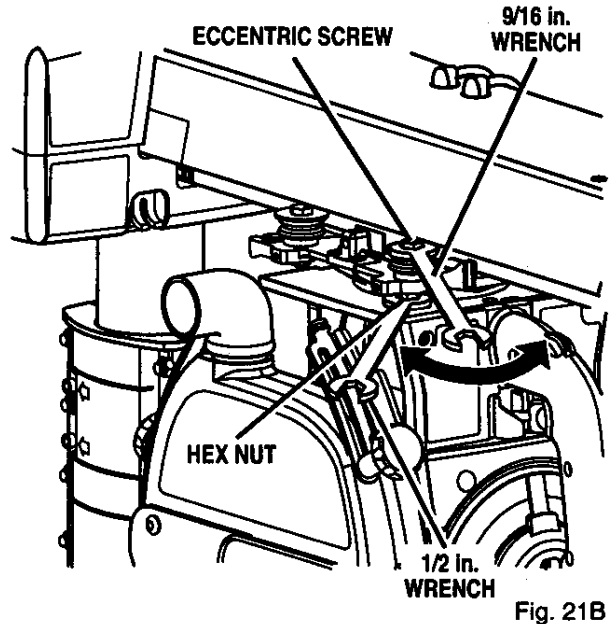

## ASSEMBLY

### LEVELING THE TABLE SUPPORTS

See Figures 22A and 22B.

The table supports must be perfectly level.

- Pull the bevel lock lever forward to unlock it. Use the bevel index knob to rotate the motor so the arbor shaft points down. Lock the bevel lock lever.
- Release the arm lock knob to angle the arm. Begin by positioning the arbor shaft over the back of the highest table support. Normally this is the left side. See Figure 22A.
- Lock the arm lock knob and the carriage lock knob.
- Using one of the blade wrenches as a feeler gage, place it on the table support below the arbor shaft.
- With the elevating handwheel, carefully lower the motor until the shaft just touches the wrench. The wrench should move with only slight resistance. Securely tighten the back screw on the table support.
- Without changing the elevation, move the arm to place the blade arbor over the front of table support. See Figure 22B.
- Place the wrench below the shaft and check that the clearance is the same. If not, adjust the table support until it is the same. Securely tighten the front screw.
- Move the arm to the opposite side and repeat the above procedure. When the opposite side is level, recheck the first side to make sure that it is still accurate and even.
- Return the saw and motor to normal height and position.

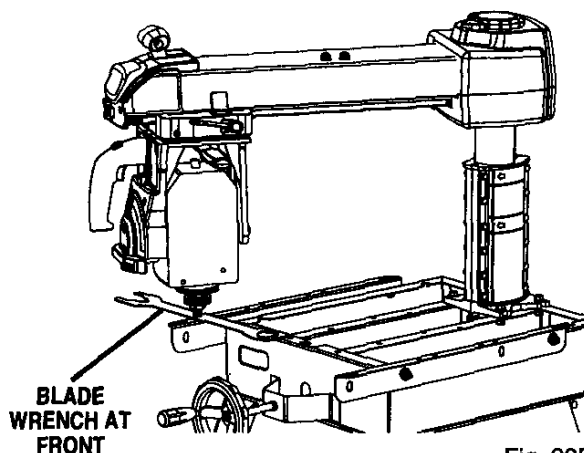

Fig. 22B

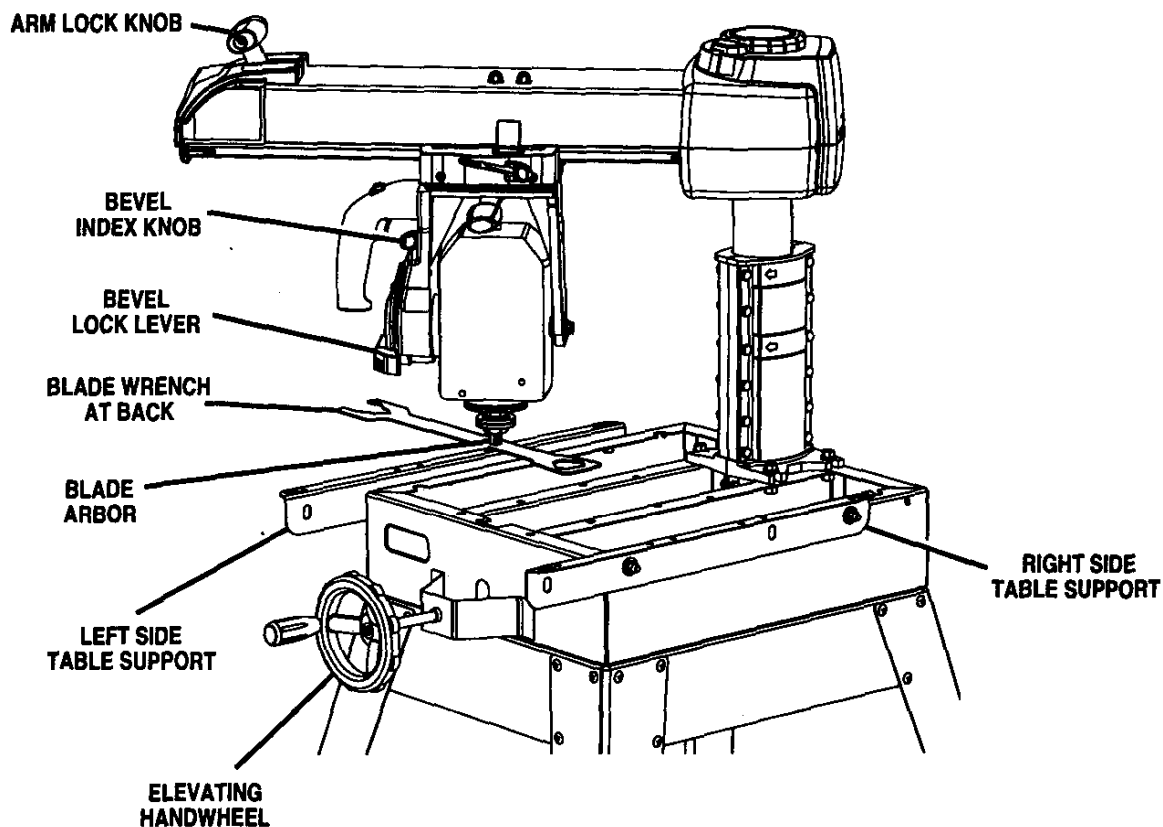

Fig. 22A

## ASSEMBLY

### INSTALLING THE FRONT TABLE

See Figures 23A - 23C.

Use this procedure to install the fixed front table.

The top of the table has counterbored holes, predrilled from the top, around the center to attach the table. In the center are a counterbored hole and a small hole, which is not counterbored. They are used for raising or lowering the center of the table until it is level.

■ Locate the front table and the following hardware:

- 1 tee nut
- 1 U-clip (1/4 in.)
- 1 setscrew (1/4-20 x 7/8 in.)
- 4 pan head screws (1/4-20 x 1 in.)
- 1 pan head screw (1/4-20 x 1-3/4 in.)
- 5 flat washers (5/8 in.)
- 4 lock washers (1/4 in.)
- 4 hex nuts (1/4-20)

■ Place the front table on a solid worksurface, with the top surface face down. Place the tee nut in the non-counterbored hole and tap it in place with a hammer.

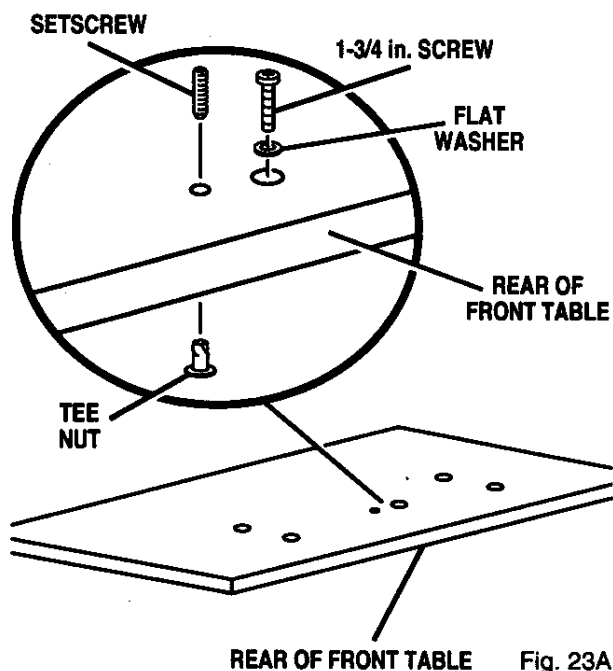

- Snap the U-clip onto the front edge of the saw base. Line up the hole in the U-clip with the saw base hole just to the left of the center notch in saw base. See Figure 23B.
- Place the table, top up, on the table supports so the center counterbored hole lines up over the hole in the U-clip.
- Place a flat washer in each counterbored hole.

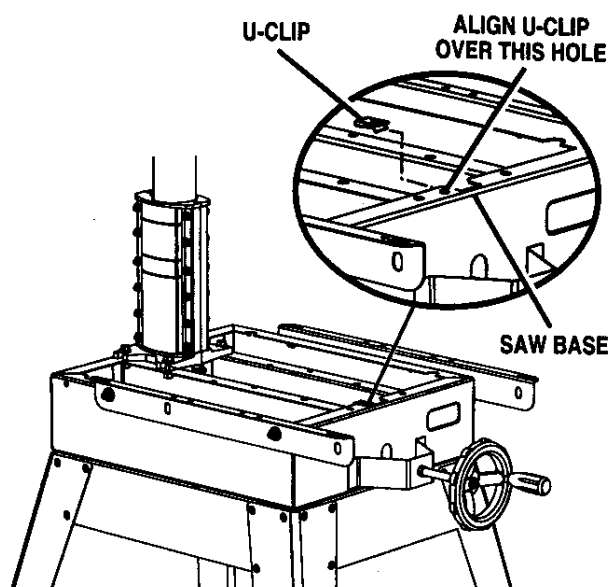

- Place the long pan head screw into the center hole and thread into the U-clip. Do not tighten until the table has been checked for evenness. See Figure 23A.
- Place the setscrew through the small leveling hole and thread into the tee nut, but do not tighten.
- Put a 1 in. long pan head screw in the four remaining holes and through the holes in the support. Cap with a lock washer and hex nut. Tighten with a 7/16 in. wrench and phillips screwdriver. This completes installation of the front table.

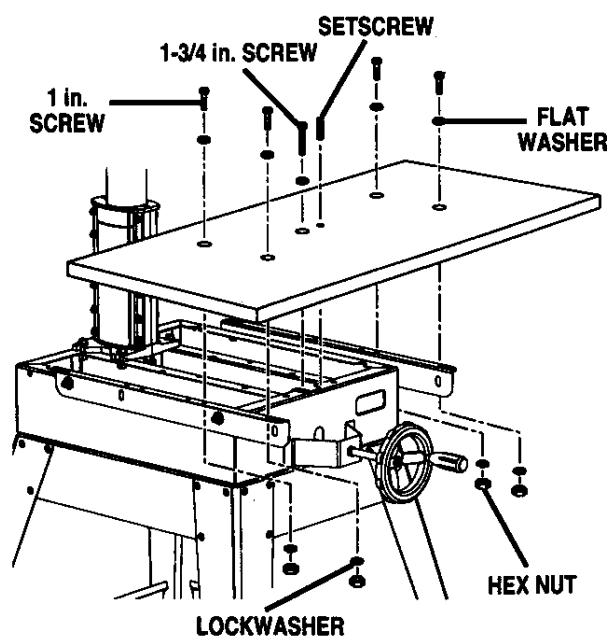

## ASSEMBLY

### LEVELING THE FRONT TABLE

See Figure 24.

If there are any high or low areas on the front table, they should be removed by adjusting the leveling screws in the center holes on the front table.

- Place the rear table on its edge across the front table to check for gaps.
- Adjust gaps of less than 1/32 in. in the center of the table by turning the setscrew with a flat blade screwdriver until the setscrew touches the frame. Then lightly secure the center pan head screw with a phillips screwdriver.
- For a gap of more than 1/32 in. in the center of the table, raise the center by turning the setscrew against the frame. Then lightly secure the center pan head screw with a phillips screwdriver.
- For a gap of more than 1/32 in. on the sides, lower the center of the table by tightening the center pan head screw with a phillips screwdriver. Then tighten the setscrew.

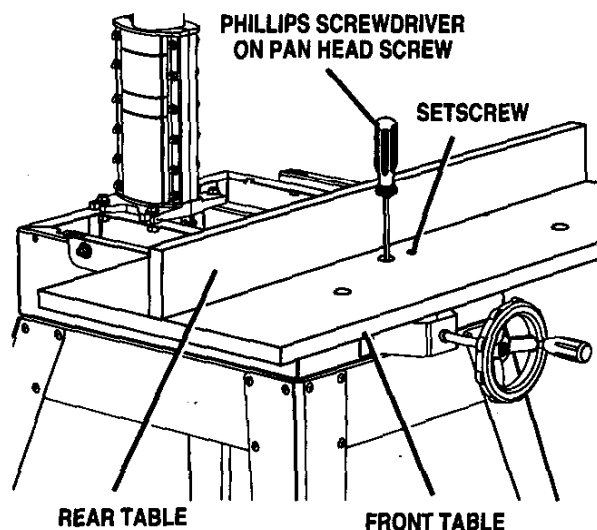

Fig. 24

### INSTALLING REAR TABLE, SPACER TABLE, FENCE, AND CLAMPS

See Figures 25A - 25C.

The placement of the tables and fence may need to be changed for different cuts, depending on the size of the workpiece and the position of the blade. The fence should be installed next to the front table for maximum depth capacity; it should be installed in the middle for maximum cross cut capacity; and installed all the way back for maximum rip capacity.

- Locate the fence, the spacer table, the rear table, and two unassembled clamps, which consist of the following hardware:
  - 2 cup washers
  - 2 clamp brackets
  - 2 square nuts
  - 2 thumbscrews
- Place the fence behind the front table, then the spacer table behind it, and then the rear table behind it.
- Slip a square nut into the slot of each clamp bracket.
- Place a thumbscrew into the end of the clamp bracket farthest from the slot. Thread it into the square nut.

**Note:** If the screw is inserted in the wrong end of the bracket, the clamp will not work.

- Place the clamp bracket into the rectangle holes in the table support. Hold the cup washer against the rear table and turn the thumbscrew clockwise until it snaps into the cup washer.
- Tighten the thumbscrews to clamp the table sections into place.

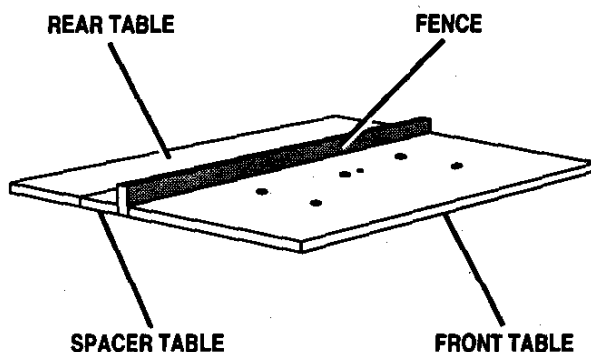

Fig. 25A

## ASSEMBLY

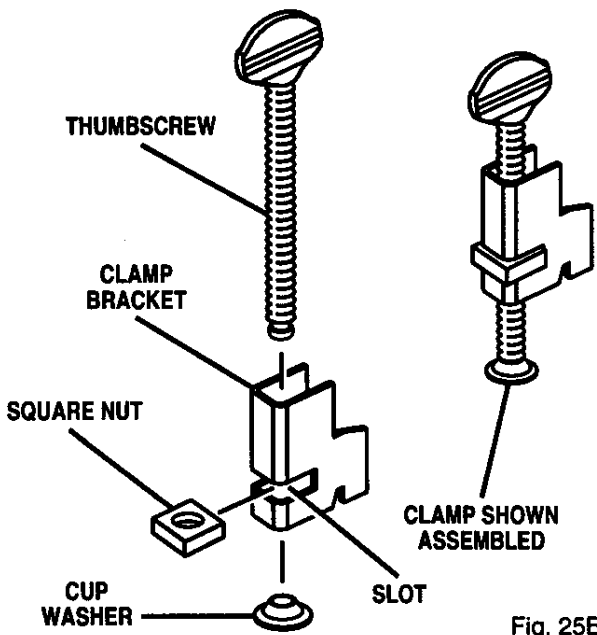

Fig. 25B

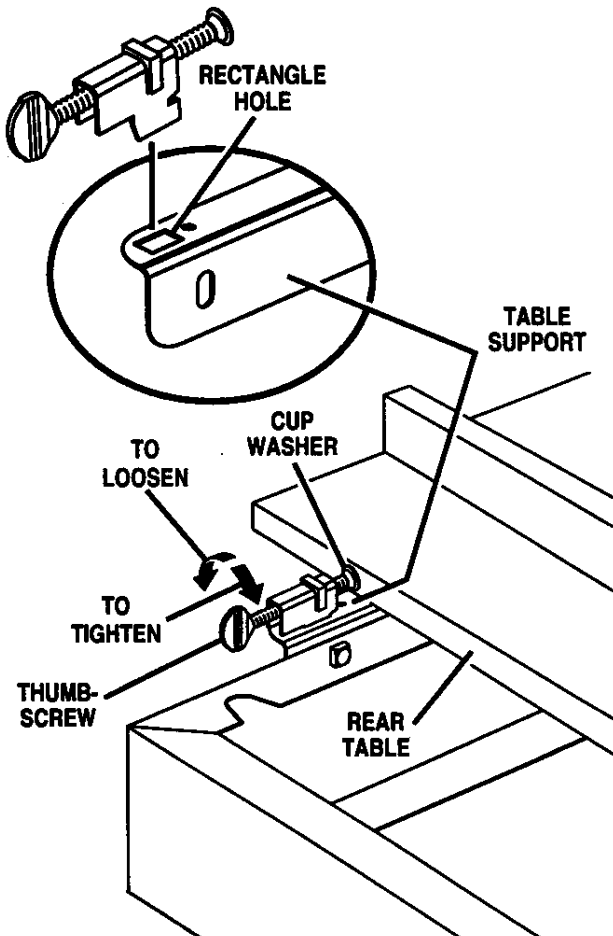

Fig. 25C

### INSTALLING BLADE AND BLADE GUARD

See Figures 26A – 26C.

- Collect the blade and hardware that were removed earlier. Place the inner blade washer, saw blade, outer blade washer, and blade nut on the blade arbor. See Figure 26A. **Note:** The concave side of blade washers go against the blade.
- Hold the blade arbor with one wrench and rotate the other blade wrench counterclockwise (up), to tighten the blade nut. See Figure 26B. **Note:** Blade arbor has left hand threads. Test the blade to make sure it turns freely.
- Use the bevel index knob (above the handle) and the bevel lock lever (below the handle) to set and lock the motor at 0°. The blade will be vertical.
- Attach the blade guard over the blade so the riving knife and pawls face front. See Figure 26A.
- Tilt the guard approximately 45° down in the front, place it over the blade, and rotate it to a horizontal locked position.
- Retighten the blade guard clamp screw, the long thumbscrew located between the blade guard and the motor.
- Check that the guard is firmly seated in the groove on the motor housing.
- Tighten the guard clamp screw.
- Replace the retaining screw and nut at the bottom of the lower inner blade guard. See Figure 26C.

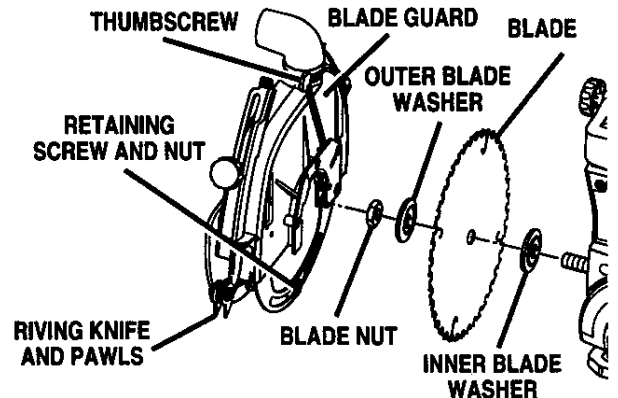

Fig. 26A

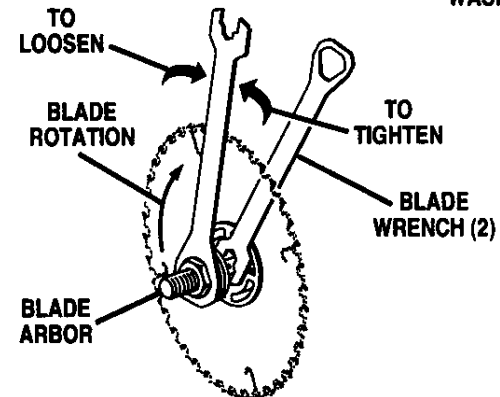

Fig. 26B

## ASSEMBLY

Orient inner slotted metal strip so that it is located to the left of outer slotted metal strip.

To prevent binding, align flats of retaining screw nut in slots of inner slotted metal strip.

Insert retaining screw through outer slotted metal strip and thread into retaining screw nut. Tighten retaining screw securely.

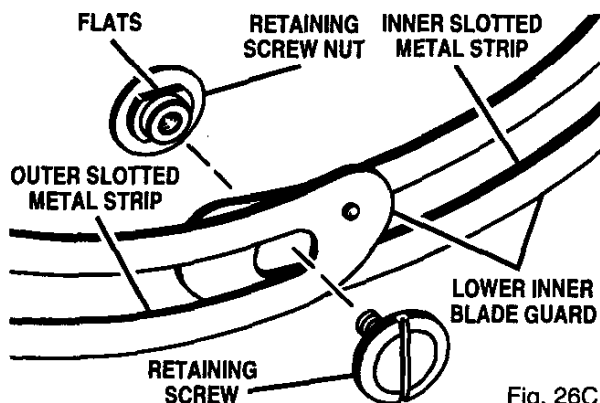

Fig. 26C

### ALIGN RIVING KNIFE TO BLADE

See Figures 27A - 27C.

When ripping the riving knife must be centered with the blade to ride in the middle of the kerf and keep it from binding. Binding pinches the blade. Blade pinching can cause kickback.

There are two pairs of anti-kickback pawls.

**⚠ WARNING:** Failure to use the riving knife, hold downs, and anti-kickback pawls can allow kickback. Kickback can throw the workpiece toward the operator, resulting in serious injury.

Put the blade to the in-rip position by first loosening the yoke lock handle, below the carriage on the right. Then pull the yoke pivot latch (right side of arm, on carriage) forward and rotate the yoke to the left. This indexes the yoke 90° so the blade is

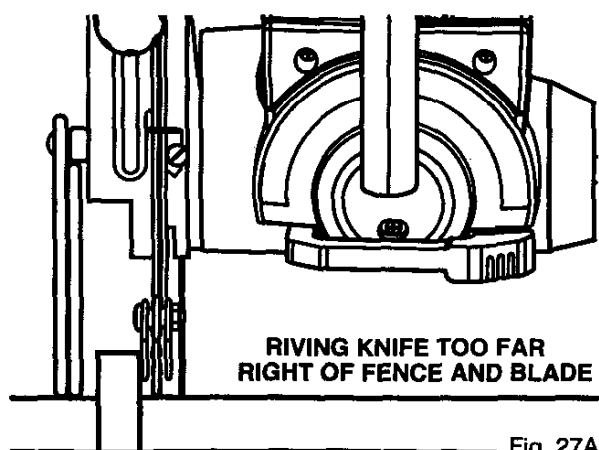

Fig. 27A

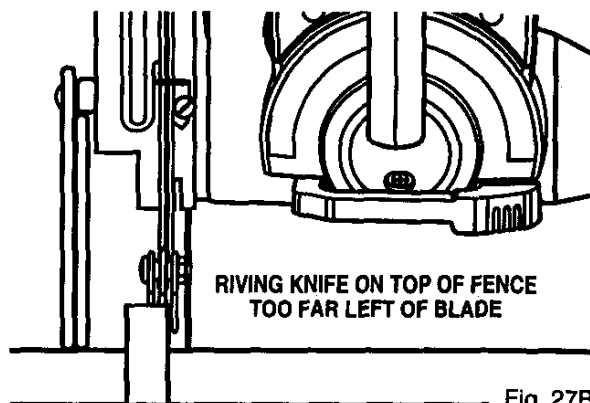

Fig. 27B

between the motor and the column. Lock the yoke lock handle.

With the elevating handwheel, lower the arm until the blade just clears the table.

Support the lower outer blade guard and loosen the carriage lock knob on the left of the arm. Move the yoke back until the blade touches the fence. Reset the carriage lock knob.

Loosen the riving knife knob, at the front of the upper blade guard. Lower the riving knife to the table and tighten the knob. If the knife rests against the fence, with one set of pawls riding on the fence, no adjustment is needed.

If the riving knife is on the fence or not touching it, loosen the riving knife slotted nut (just above the pawls, to the right). Correct the riving knife position and retighten the cap nut.

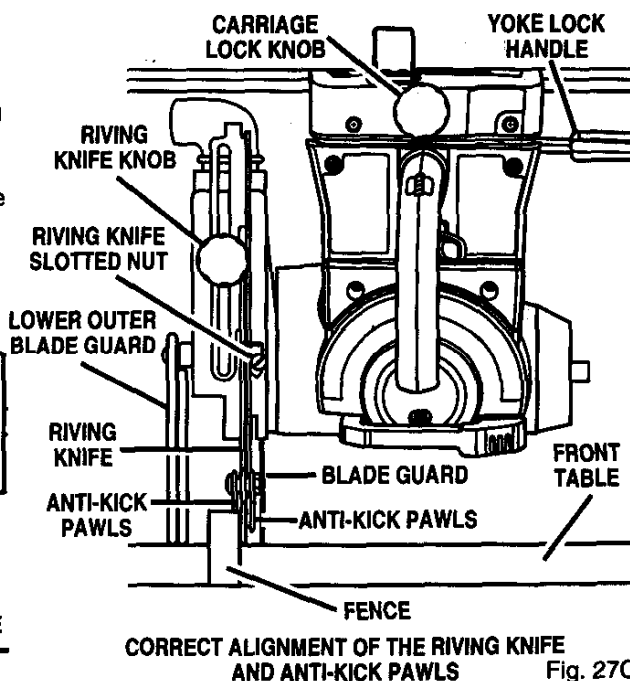

Fig. 27C

## ASSEMBLY

### INSTALLING RIP SCALE INDICATORS

See Figure 28.

The rip scale indicators on the arm show the distance between the blade and the rip fence with the fence in the front and rear positions. The upper scale is used when the fence is positioned directly behind the front table. The lower scale is used when the fence is at the extreme rear, directly in front of the column.

The In-Rip Indicator is on the right side of the arm.  
The Out-Rip Indicator is on the left side of the arm.

- Remove the following from a small hardware bag.
  - 2 rip scale indicators
  - 4 screws
  - 2 speed nuts
- On the left of the radial arm saw, remove the carriage lock knob and spring.
- Remove the two carriage cover screws and the carriage cover.
- Insert a speed nut inside the carriage cover with the flat side up. Place the scale indicator on top of the carriage cover and attach with two screws. Securely tighten screws.
- Replace the carriage cover and tighten the carriage cover screws.
- Replace carriage lock knob and spring.
- Repeat for the right side.

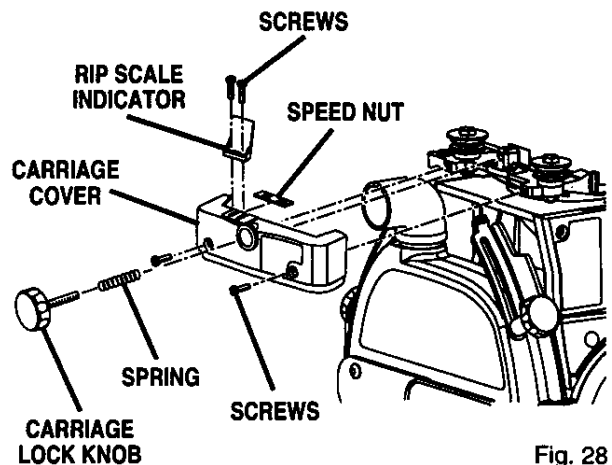

Fig. 28

To complete setting up your saw, continue with the Adjustment procedures. The adjustments should be checked regularly, depending on usage. Your saw will provide accurate cuts with fine tolerances as long as you protect the accuracy with frequent alignment checks. The radial arm saw can perform a wide range of high quality cuts.

The final step will be connecting the control cut device. The control cut device offers many benefits. As it increases operator control, it eliminates the risk in a cross cut of the saw "climbing" out and over the workpiece at the operator. Feed control of the blade as it cuts through the workpiece increases, as does the accuracy of the cut. The following adjustments need to be completed before the control cut device is connected.

## ADJUSTMENTS

Your radial arm saw is designed to perform a variety of complex cuts with fine tolerances. A weekly alignment check ensures that your saw can perform with precision. It takes about ten minutes and the results is better performance and a longer life for your saw.

Perform the checks in the order given. If you miss an adjustment, go back to the missed adjustment and repeat all steps from that point forward.

- ⚠ **CAUTION:** Failure to check alignments and perform the adjustments in the initial set up or on a frequent basis can result in poor performance or machine damage.

## ADJUSTMENTS

### ALIGNING THE ARM FOR CROSS CUTS

See Figures 29A – 29C.

This procedure checks whether the arm is exactly 0° for cross cut travel by checking the blade against the table and the miter indicator. Remove the rear table, spacer table, and fence, but leave the front table in place. You will need a framing square, a 3/16 in. hex key, and a pencil.

**⚠ WARNING:** Be sure the saw is unplugged before performing these adjustments. Accidental start-up could result in serious personal injury.

- First check the framing square by fitting one side against the back edge of the table. Lightly draw a line on the table along the edge of the square in the middle of the table. Flip the square over. If the edge still matches the line with no gaps or overlaps, the square is true.

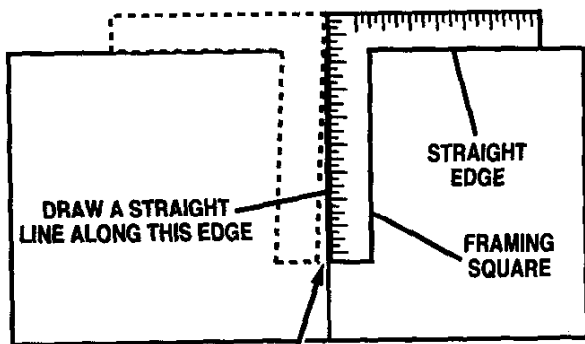

THERE SHOULD BE NO GAP HERE WHEN SQUARE IS FLIPPED OVER TO DOTTED POSITION

Fig. 29A

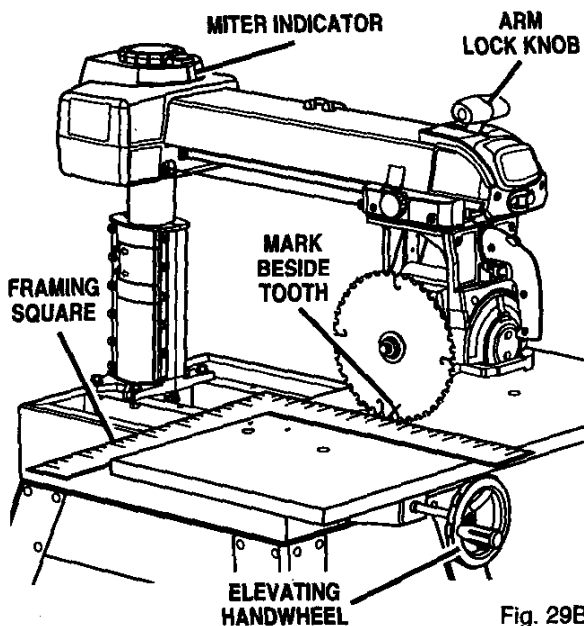

Fig. 29B

- Release the arm lock knob. Position the arm straight forward (0°) and leave it unlocked.
- Lower the arm with the elevating handwheel until the saw blade just clears the front table. Lock the yoke lock handle (right side of saw, below yoke) and the bevel lock lever.
- Place the framing square on the table and position one edge of the square firmly against the back edge of the table. Position the other leg of the square against the blade until it rests beside but not touching a tooth. With a pencil, mark beside this tooth.
- Slowly move the yoke assembly forward and backward along the arm and against the square without rotating the blade. If the mark moves into or away from the square, adjust the arm with the following steps.
- At the back of the column, loosen the three setscrews with a 3/16 in. hex key and position the arm as needed to align with the framing square.
- Lock the arm lock knob and retighten the three setscrews. Recheck the cross cut travel with the blade against the framing square.
- Set the miter indicator on top of the column to 0°
- Replace the fence, spacer table, rear table, and table clamps.

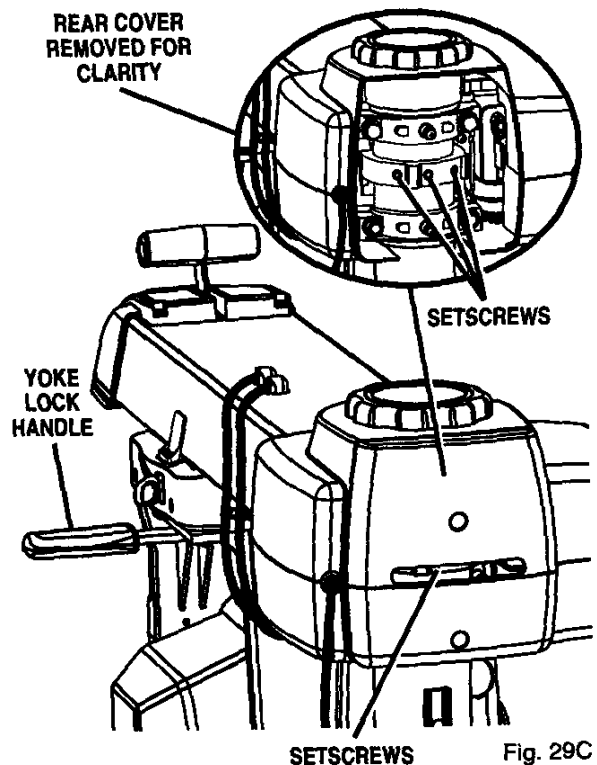

Fig. 29C

## ADJUSTMENTS

### ALIGNING BLADE TO TABLE AT 0° BEVEL

See Figures 30A - 30D.

This procedure squares the blade to the table at 0° bevel (vertical) so the blade angle will be accurate. If the blade is not at 0° bevel, follow the steps below to rotate slightly. You will need a framing square and a 1/4 in. hex key.

- Position the blade in front of the fence. Lower the blade with the elevating handwheel until it just clears the front table.
- Lock the following controls:
  - bevel lock lever below the handle,
  - carriage lock knob on the left side,
  - arm lock knob on top of the arm, and
  - yoke lock handle below the yoke, on the right.
- Stand a framing square on the table with the short leg pointing up against the saw blade and the long leg parallel to the fence. Place the square flat against the blade between two teeth.
- If both the top and bottom of the saw blade are flat against the square, no adjustment is needed.
- If the saw blade gaps at the top or bottom, remove the bevel index cap by removing the two phillips head screws (below the handle). You will see four socket head screws.
- Loosen the socket head screws with a 1/4 in. hex key. Rotate the motor slightly while holding the square against the saw blade and table top.
- Slightly tighten each of the four screws and recheck the blade and framing square.

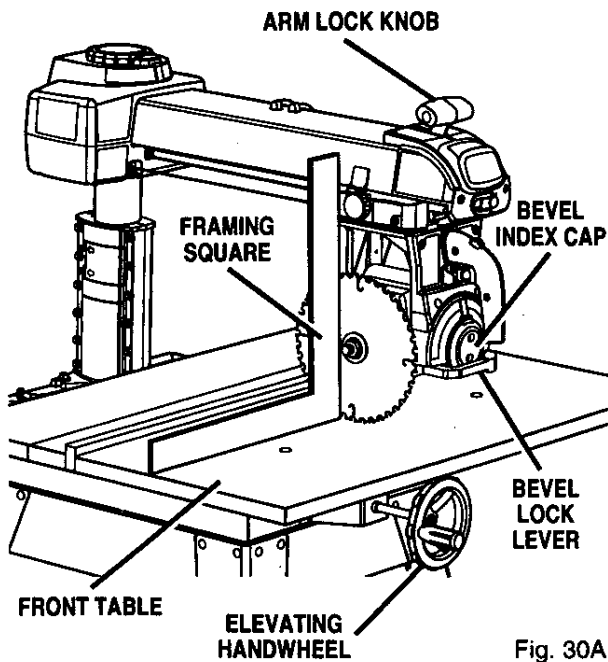

- If there are no gaps, fully tighten each screw. If there is still a gap, repeat the previous two steps.
- Check the bevel indicator on the yoke assembly near the handle. It should read 0°. If it does not, reset it by loosening the screws and rotating the bevel index cap. Retighten the two screws.
- Loosen the carriage lock knob.

### BLADE SQUARE TO TABLE

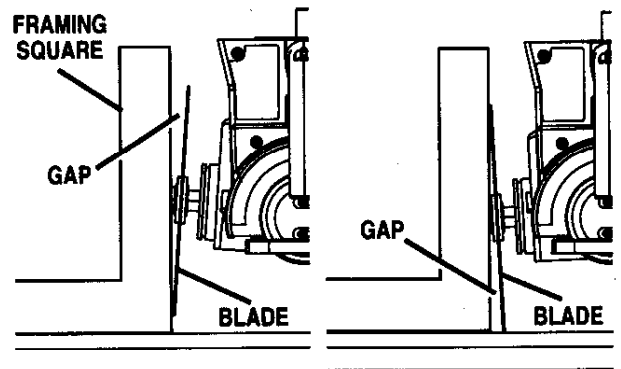
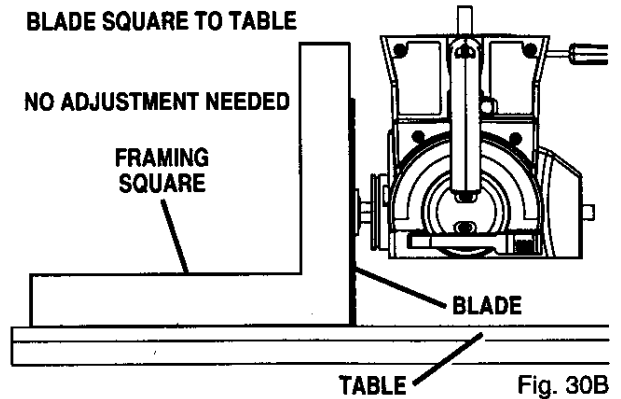

GAP - ADJUSTMENT NEEDED Fig. 30C

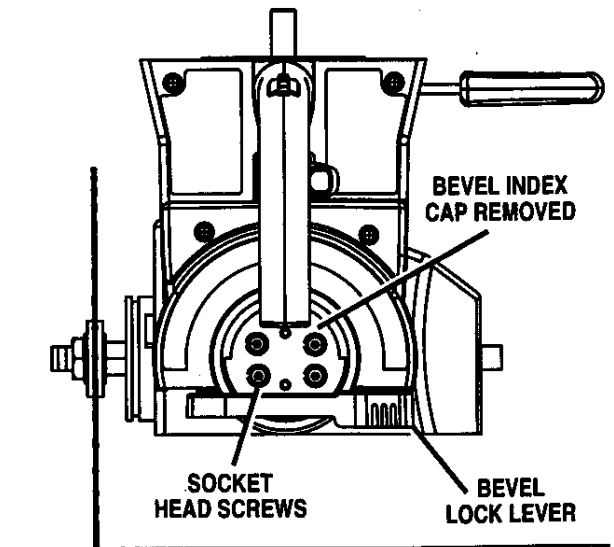

Fig. 30D

## ADJUSTMENTS

### SQUARING BLADE TO FENCE

See Figures 31A - 31C.

This procedure squares the miter angle of the blade to the fence to reduce the risk of binding and kickback. If the blade is not square to the fence, the yoke assembly must be rotated slightly. Have a framing square, a 1/2 in. wrench, and a phillips screwdriver at hand. The blade should be lowered to just clear the table. Release the carriage lock knob.

**⚠ WARNING:** The blade must be angled at 90° to the fence when the handle is at the front of the saw. If not, kickback could result during a cross cut. Kickback can cause serious injury by throwing the workpiece toward the operator. In addition, a faulty miter angle on the blade can splinter or burn the cut edges of the workpiece during cross cuts or rip cuts.

- Use the arm lock knob to index and lock the arm in 0° miter position (straight forward).
- Pull the yoke assembly forward to the front of the arm. Lock the carriage lock knob.
- Place the short end of the framing square against the fence. Rotate the square to 45° to the table. Place the long edge across the flat surface of the blade, below the center of the blade. (Do not place the edge against a tooth.)
- Check whether the blade is flat against the edge for the entire length or whether a gap is visible.
- If the blade needs adjustment, remove the right side carriage cover with a phillips screwdriver.

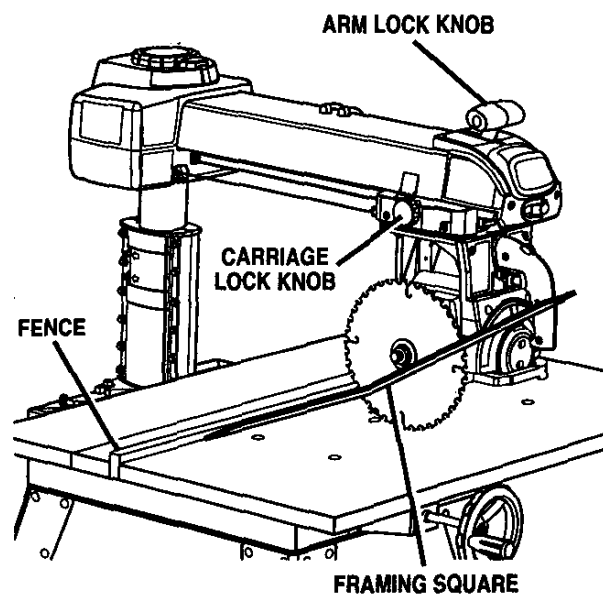

Fig. 31A

- Release the yoke lock handle (below the yoke on the right). With a 1/2 in. wrench, slightly loosen the two hex bolts holding the yoke pivot latch.
- Rotate yoke assembly until the gap is eliminated.
- Lock the yoke lock handle. Retighten the two hex bolts on the yoke pivot latch.
- Replace the carriage cover.
- Loosen the carriage lock knob and guide the yoke assembly to the back of the arm.

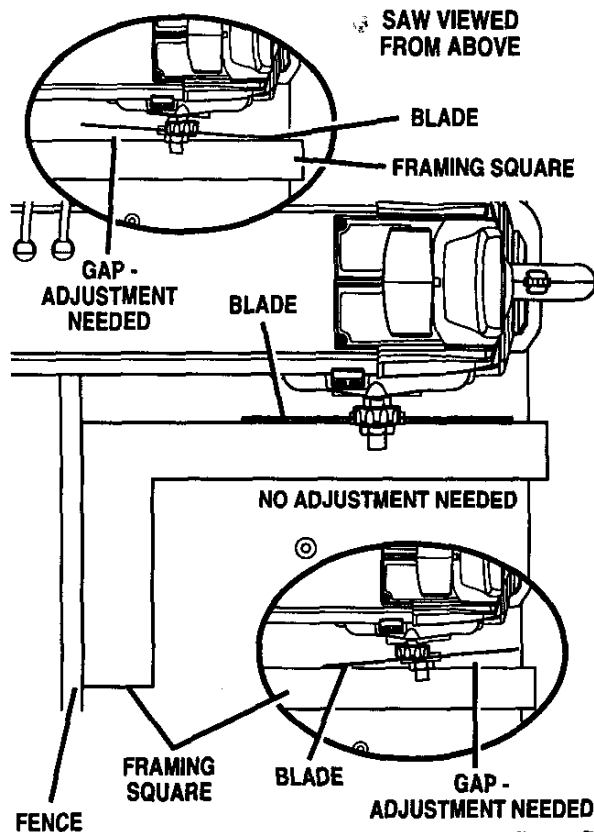

Fig. 31B

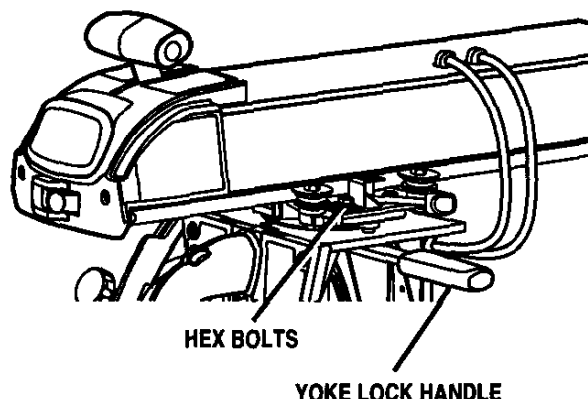

Fig. 31C

## ADJUSTMENTS

### PARALLELING BLADE TO TABLE

See Figures 32A-32C.

This procedure squares the blade to the table at 90° bevel so horizontal cuts will be accurate. This also reduces kickback, as well as splintering and burning of the cut edges of the workpiece. If the blade is not at 90° bevel, follow the steps to rotate the blade unit slightly. You will need a framing square and a flat blade screwdriver.

**⚠ WARNING:** The blade must be perfectly parallel to the table at the 90° reading on the bevel scale. If not, kickback could result, as well as splintering or burning the cut. Kickback can result in serious personal injury as the workpiece can be thrown at the operator.

- Use the arm lock knob to lock the arm in 0° miter position (straight forward).
- Turn the elevating handwheel to raise the blade at least 2 in. above the table.
- Release the bevel lock lever below the handle. Use the bevel index knob, just under the handle, to turn the motor to 90°. The blade will be horizontal. Lock the bevel lock lever.
- Place the framing square with the short end hanging down in front of the worktable and the long side on edge under the blade.
- Lower the arm with the elevating handwheel so the blade surface rests on the square. Turn the blade slightly if necessary so the face of the blade, not a tooth, lies on the square.

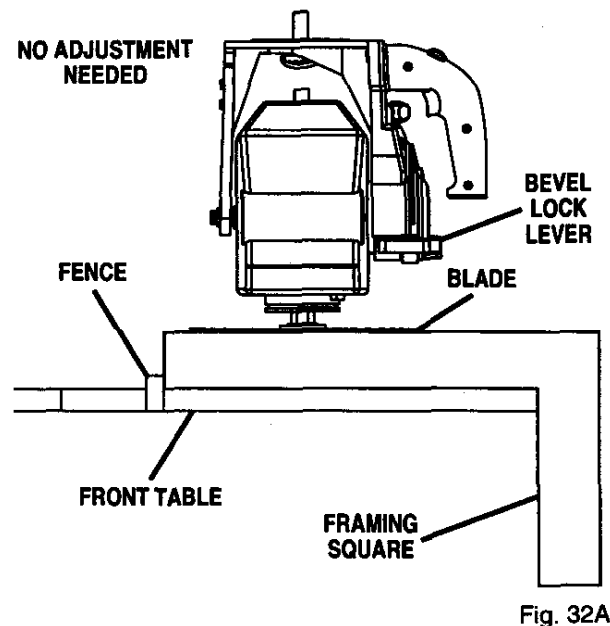

Fig. 32A

- Check whether the blade is flat against the edge the entire length or whether a gap is visible. If you can see a gap, adjust the blade to be at 90° bevel to the table with the following steps.
- Unlock the bevel lock lever. Loosen the rear motor mount nut, which holds the motor on the yoke. Place a flat blade screwdriver in one of the slots, and rotate the cam behind the nut to eliminate the gap between the blade and the square.
- Retighten the nut.
- Tighten the bevel lock lever. Recheck the blade and the square for any gaps.
- Raise the blade with the elevating handwheel to approximately halfway up. Index the blade to a vertical 0° bevel with the bevel index knob. Lock it with the bevel lock lever.

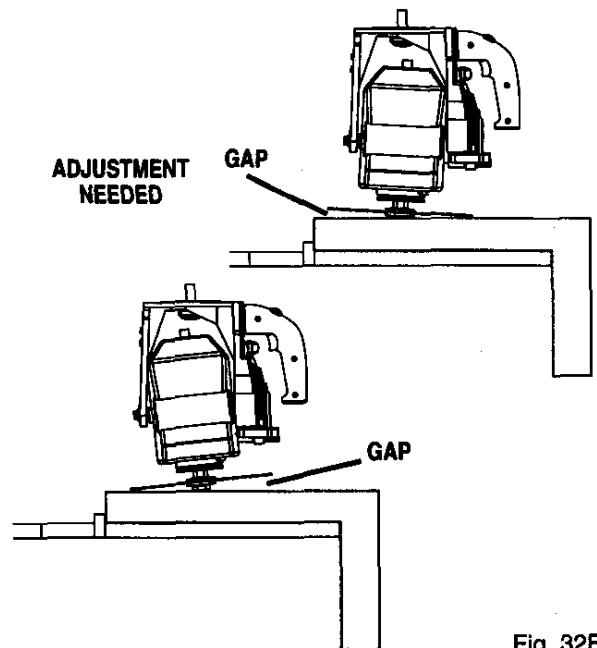

Fig. 32B

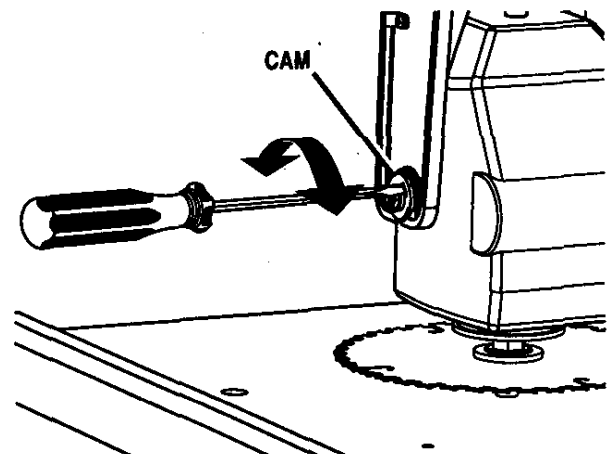

Fig. 32C

## ADJUSTMENTS

### ALIGNING THE RIP SCALE INDICATORS

See Figures 33A - 33B.

The rip scale indicators on the arm show the distance between the blade and the rip fence. The upper scale is used when the fence is positioned directly behind the front table. The lower scale is used when the fence is at the extreme rear, directly in front of the column.

The in-rip indicator and scale are on the right side of the arm. The out-rip indicator and scale are on the left side.

This procedure checks the indicators with the fence at the back of the tables directly in front of the column. The blade should be turned to the in-rip position to set the rip scale indicator on the right side of the arm. Then, the blade should be turned to the out-rip position to set the rip scale indicator on the left side of the arm. You will need a framing square.

- If the fence is not at the rear of the tables, place it there.
- Turn the blade to the in-rip position by loosening the yoke lock handle, below the arm on the right. Then pull the yoke pivot latch forward and rotate the yoke to the in-rip position. This indexes the yoke 90° so the blade is between the motor and the column. Lock the yoke lock handle.
- With the elevating handwheel, lower the arm until the blade just clears the table.
- Loosen the carriage lock knob and guide the blade back to just touch the fence. Tighten the carriage lock knob.

IN-RIP SCALE ON RIGHT SIDE OF ARM

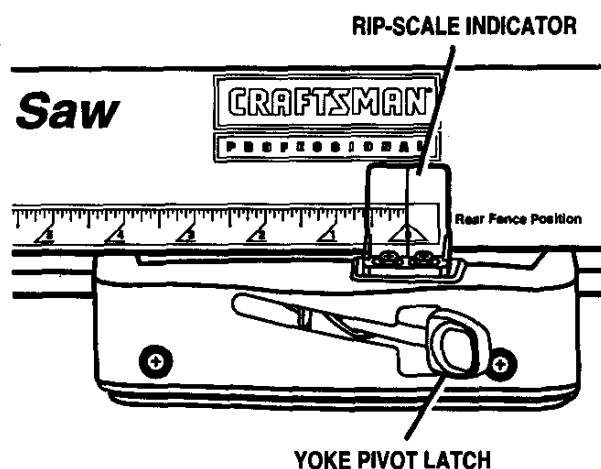

Fig. 33A

- On the right side of the arm, check the lower in-rip scale indicator, which should be set on 0 inches. If it is not, loosen the screws and shift the indicator until it reads zero. Tighten the screws.
- Loosen the yoke lock handle. Pull the yoke pivot latch forward and rotate the yoke to the out-rip position. The blade should be in front of (outside) the motor and the column.
- Lay the framing square on the table with the short edge against the fence and with the long side toward the table front.
- Note the distance where the blade contacts the framing square.
- On the left side of the arm on the out-rip scale, check the rip scale indicator on the rear fence position (lower scale). The rip scale indicator should mark the same number as the distance measured from the fence to the blade. If it does not, loosen the screws and shift the scale until the indicator is correct. Tighten the screws.

OUT-RIP SCALE ON LEFT SIDE OF ARM

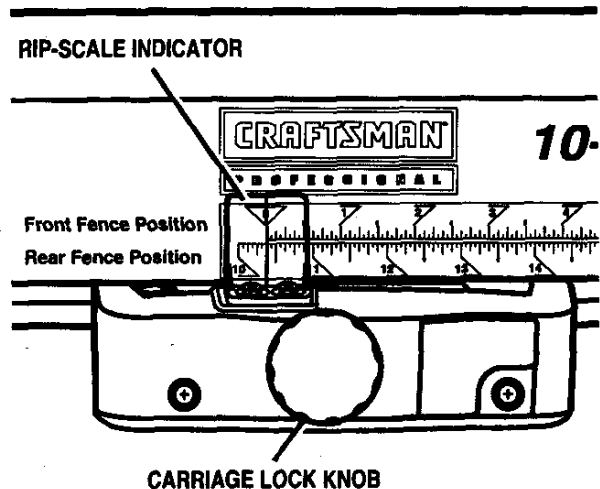

Fig. 33B

## ADJUSTMENTS

### INSTALLING CONTROL CUT DEVICE

See Figure 34.

**Note:** Before installing the control cut device, the yoke assembly will travel back and forward on the carriage by pulling the handle. After installing the control cut device, the power cord for the control cut device must be plugged in and switch trigger pressed to move the yoke assembly and carriage on the arm.

**WARNING:** Do not install the control cut device until after all of the initial adjustments and alignments are made to prevent accidental starting of the saw that could result in serious personal injury.

The control cut device offers many benefits. As it increases operator control, it eliminates the risk in a cross cut of the saw "climbing" out and over the workpiece at the operator. Feed control of the blade as it cuts through the workpiece increases, as does the accuracy of the cut.

The control cut cable maintains a steady pull on the carriage assembly from the column. This tension keeps the assembly at the column, unless you squeeze the switch trigger in the handle. The switch trigger activates the motor to counter the pull of the cable.

After a cut is completed, press the switch on the arm off, then release the switch trigger to prevent further forward motion. Hold the handle until the blade has stopped rotating. The yoke assembly will not roll forward unless you are squeezing the switch trigger.

The control cut power cord is designed to operate on a single voltage AC circuit. The speed can be set with a thumbwheel on top of the handle. The three speed settings are described on the label located on the left side of the control cut housing.

**WARNING:** Do not use the saw without the control cut and blade guards in place unless specifically instructed to do so. Otherwise uncontrolled contact with the blade could occur, resulting in personal injury.

**WARNING:** Take great care when working with either cord to ensure you have the correct one. If you intend to unplug the main power cord but remove the control cut cord instead, the blade could be accidentally started and cause injury.

- Plug in the control cut cord, leaving the main power cord disconnected. Squeeze the switch trigger to confirm the control cut motor is receiving power.
- On the left side of the saw, remove the carriage lock knob and spring. Remove the two screws that attach the carriage cover and remove the cover.
- Replace the spring and carriage lock knob. Pull the carriage assembly about halfway to the front. Tighten the carriage lock knob.
- Squeeze the switch trigger in the handle with your right hand and pull the spring loaded cable from the column with your left hand. If you prefer to use a pair of pliers, do not damage the cable. **Note: Do not** to let the spring loaded cable clamp slip out of your hand or pliers. If it slips past the cable bracket and goes up into the control cut motor housing, then disassembly of the control cut assembly will be required to get it back out.
- Place the barrel fitting into the socket at the back of the carriage assembly.
- Remove the carriage lock knob and spring. Replace the carriage cover and screws, then replace the spring and carriage lock knob.
- Set the speed thumbwheel, using the chart on page 53. If you are unsure of the proper speed setting, use the lowest setting.

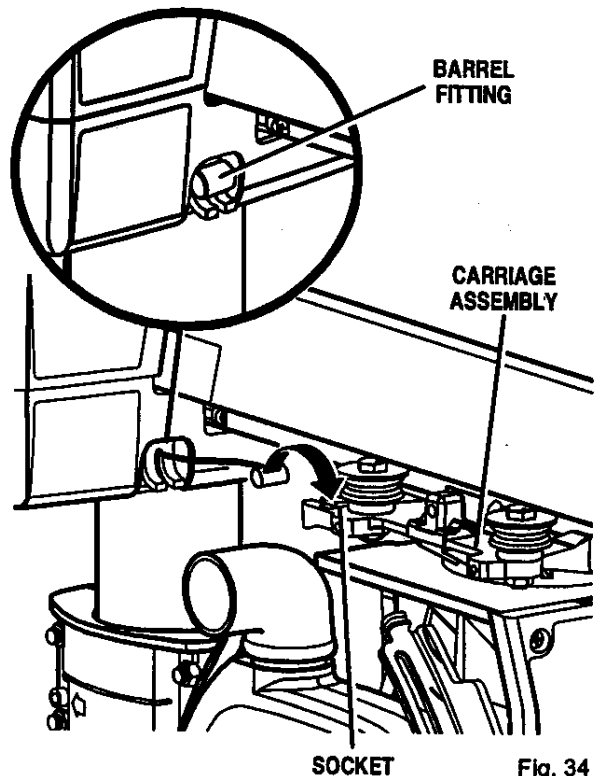

Fig. 34

## OPERATION

### BASIC OPERATION OF THE RADIAL ARM SAW

A radial arm saw can be used for straight-line cutting operations such as cross cutting, ripping, mitering, beveling, compound cutting, and resawing. It can make dado or molding cuts with special attachments. This saw is designed to cut wood and wood composition products only.

The three-prong plug must be plugged into a matching outlet that is properly installed and grounded according to all local codes and ordinances. Improper connection of the equipment can result in electric shock. Check with an electrician or service personnel if you are unsure about proper grounding. Do not modify the plug; if it will not fit the outlet, have the correct outlet installed by a qualified electrician. Refer to the Electrical page of this manual.

### TYPES OF CUTS

See Figure 35.

The radial saw makes cross cuts parallel with the arm (across the grain), and rip cuts square to the arm (with the grain). Each can be made with the blade vertical or beveled. Instructions for making each kind of cut are given later in this section.

**WARNING:** All blades and cutting accessories must be rated for at least 5,000 rpm to prevent possible injury.

### CROSS CUTS

Cross cuts are made parallel to the arm. The blade is pulled along the length of the radial arm with the wood secured.

There are several types of cross cuts. A *cross cut* shows 0° on the miter scale (arm straight) and 0° on the bevel scale (blade straight). A *miter cut* is made with the radial arm angled and the blade straight. A *bevel cut* is produced with the arm straight and the blade angled.

A final type of cross cut is the *compound cross cut*. Both the arm and the blade are angled. Be thoroughly familiar with making cross cuts, bevel cuts, and miter cuts before trying a compound miter cut.

**Note:** In cross cuts, the blade teeth point down as they strike the wood. In rip cuts, the teeth point up as they strike the wood.

**WARNING:** NEVER make a cross cut with the short edge of the wood parallel to the fence. Kick back is likely to occur, causing the workpiece to be thrown back at you. Treat such a workpiece as a rip cut.

### RIP CUTS

In rip cuts, the yoke is rotated 90° left or right and locked in place. The wood must ride firmly against the rip fence. There are two orientations of rip cuts - the in-rip and the out-rip. The in-rip position provides better visibility. Out-rip cuts can also be made with the blade beveled.

In an in-rip cut, the yoke is rotated to the left, which puts the blade in between the column and the motor. The wood is fed from the right hand side.

In an out-rip cut, the blade is in front of the motor, and the wood is fed from the left. Out-rip cutting is recommended only when the blade is set 12 in. or more from the fence.

**WARNING:** Always make sure the blade guard and anti-kickback pawls are in place and working properly when making rip cuts to avoid possible injury.

**WARNING:** Always use a pushstick with small pieces of wood, and also to finish the cut when ripping a long narrow piece of wood, to prevent your hands from getting close to the blade.

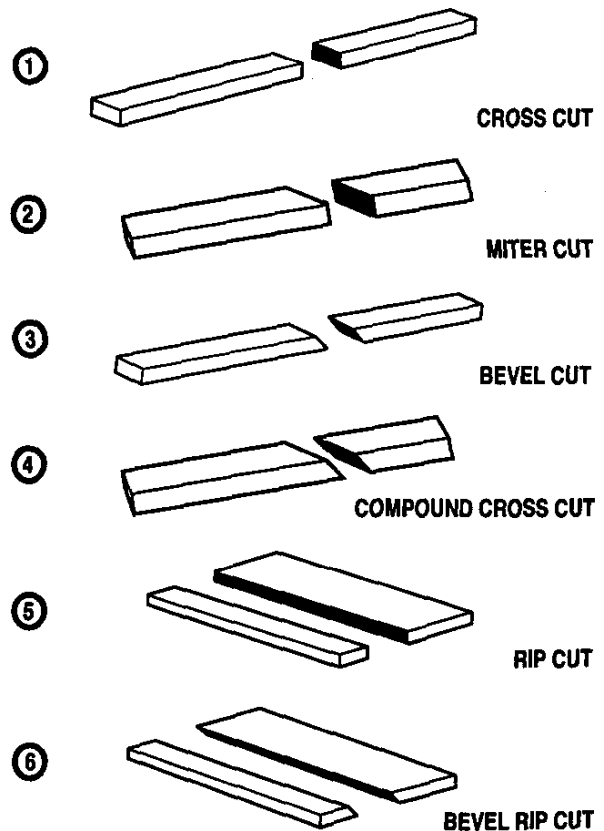

Fig. 35

## OPERATION

### SWITCH AND SWITCH KEY

See Figures 36-38.

The main power switch has been placed on the front of the arm for easy access. The yellow switch key prevents accidental starting of the main power switch when saw is not being used. To activate the switch, insert the switch key and lift switch to **ON** position. To lock the switch once it has been pressed to **OFF**, remove the yellow key. Place the key in a location that is inaccessible to children and others not qualified to use the tool.

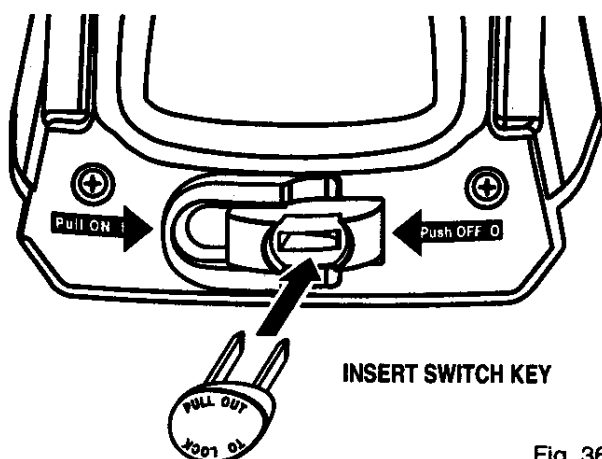

Fig. 36

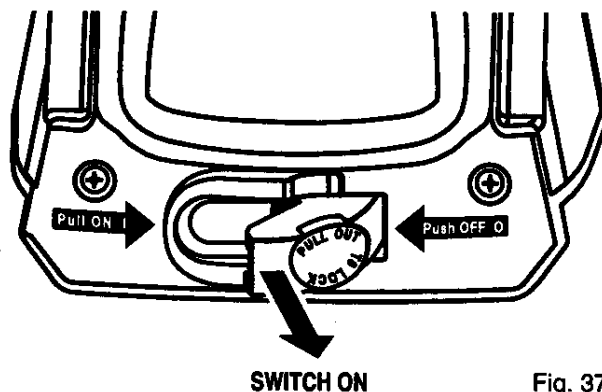

Fig. 37

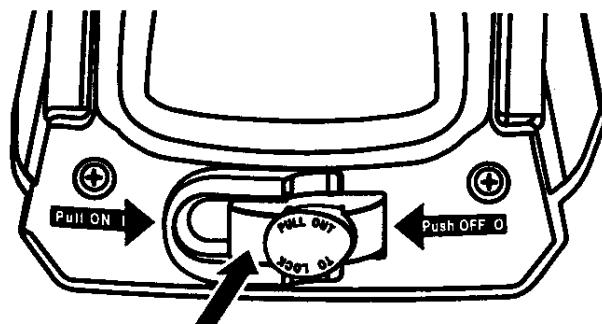

Fig. 38

### CAUSES OF KICKBACK

Kickback can occur when the blade stalls or binds, kicking the workpiece back toward you with great force and speed. If your hands are near the blade, they may be jerked loose and contact the blade. Obviously, kickback can cause serious injury and it is well worth using precautions to avoid the risks.

Kickback can be caused by any action that pinches the blade in the wood, such as the following:

- Making a cut with incorrect blade depth
- Sawing into knots or nails in the workpiece
- Twisting the wood while making a cut
- Failing to support work
- Forcing a cut
- Cutting warped or wet lumber
- Misusing the saw
- Not following correct operating procedures
- Using the wrong blade for the type of cut
- Cutting with a dull, gummed-up, or improperly set blade.

### AVOIDING KICKBACK

- Always use the correct blade depth setting. The outer point of the blade teeth should clear the lower surface of the workpiece by 1/8 in. to 1/4 in. when making these cuts.
- Inspect the work for knots or nails before beginning a cut. Knock out any loose knots with a hammer. Never saw into a loose knot or nail.
- Always use the fence when rip cutting. This helps prevent twisting the wood in the cut.
- Always use clean, sharp, and properly-set blades. Never make cuts with dull blades.
- To avoid pinching the blade, support the work properly before beginning a cut.
- When making a cut, use steady, even pressure. Never force cuts.
- Do not cut wet or warped lumber.
- Always hold your workpiece firmly with both hands or with pushsticks. Keep your body in a balanced position to be ready to resist kickback should it occur. Never stand directly in line with the blade.
- Use the right type of blade for the cut being made.
- Use the riving knife and anti-kickback pawls when performing rip cuts.

## OPERATION

### CUTTING AIDS

See Figures 39-41.

Cutting aids are used to improve the setup and help make the operator's work safer and more accurate. They can be made from scrap wood and in various sizes and shapes for specific projects.

The basic types are pushsticks, pushblocks, and featherboards. If the blade is set 2 in. or more from the fence, use a pushstick. Use a pushblock when the blade is between 1/2 in. and 2 in. from the fence. (If the cut is narrower than 1/2 in., use a different saw.) Refer to the drawings and instructions provided so you can make safer and more precise cuts.

### PUSHSTICKS

See Figure 39.

Pushsticks must be narrower than the workpiece, with a 90° notch in one end and shaped for a grip on the other end.

### PUSHBLOCKS

See Figure 40.

A pushblock has an upright handle with a base attached to the handle. Some pushblocks have a foot that extends down from the base and against the workpiece. The foot is attached to the base with glue only to prevent damage to the blade.

### FEATHERBOARDS

See Figure 41.

Featherboards are used for large panels, along with an auxiliary table and a C-clamp. A featherboard has an angled end to fit against the edge of the workpiece. It is clamped in place so the workpiece moves between either the fence and the featherboard or the table and featherboard. Slots in the end of the featherboard help resist kickback and allow for variations in the width of the workpiece.

**⚠ WARNING:** Clamp the featherboard against the infeed side of the workpiece. If clamped behind the blade, it could squeeze the cut edges together, causing binding and kickback. Kickback can cause serious injury.



PUSHSTICKS

Fig. 39

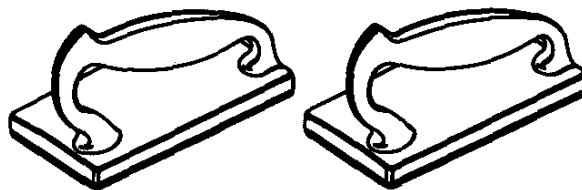
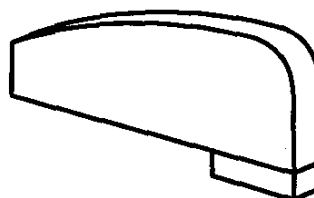

PUSHBLOCKS

Fig. 40



FEATHERBOARD

Fig. 41

**Note:** The Pushstick designs above are for illustration purposes only. They have not been drawn to scale.

## OPERATION

### MAKING A CROSS CUT

See Figure 42.

Use this procedure to make a cut with the blade vertical and straight forward. If a kerf does not exist for the line of the cut (cutting path), follow the steps to make one. Each cutting path requires its own kerf.

**WARNING:** Make sure the blade guard is lowered and is working properly to prevent possible injury. Always raise the clear plastic guard before changing the bevel or lowering the blade to avoid damage to the guard.

**WARNING:** Keep one hand on the handle until the blade stops rotating to prevent the risk of injury.

- Put the fence in the front position (next to the front table) and tighten the table clamps.
- Check that the control cut device is set for the correct speed for the type of wood and cut you are planning. Refer to the chart on the label and adjust the thumbwheel on the handle accordingly.
- If the yoke is not in the cross cut position with the blade parallel to the arm, release the yoke lock handle (right side, under yoke). Position the yoke correctly with the yoke pivot latch.
- If the arm is too low or too high, first lift the blade guard if the arm is too low, and turn the elevating handwheel at the front of the table. Set the blade to just clear the kerf or table.
- If the arm is angled, release the arm lock knob on top of the arm, position it straight ahead and lock the arm lock knob.
- If the blade is angled, raise the plastic lower guard, release the bevel lock lever, and set the bevel indicator to zero. Retighten the bevel lock lever.
- If the blade is in front of the fence, loosen the carriage lock knob on the left side of the arm. Release the switch trigger and let the carriage return to the back.
- If there is no kerf, cut one approximately 1/16 in. deep. Grasp the handle and turn the saw on with the switch on the arm. Squeeze the switch trigger on the handle and pull the blade forward across the table to make the kerf.
- Release the switch trigger and let the carriage return to the back. Turn the saw off with the switch on the arm but hold the handle until the blade stops rotating. Adjust the height with the elevating handwheel so the blade will rotate freely in the kerf.
- Position the workpiece against the fence. Place the pawls and riving knife to clear the workpiece or the fence, whichever is higher, by at least 1/4 inch.
- Grasp the handle with one hand. With the other, turn the saw on, then hold the workpiece down and against the fence. Keep your hand well away from the blade.
- Squeeze the switch trigger on the handle and pull the blade through the workpiece but only far enough to complete the cut. Keep your hand on the handle, even after the cut has been made and the saw turned off, until the blade stops rotating.
- After completing the cut, move the workpiece to the side and turn off the saw with the switch on the arm. Release the switch trigger on the handle and let the yoke move back behind the fence. Do not release the handle until the blade stops rotating.

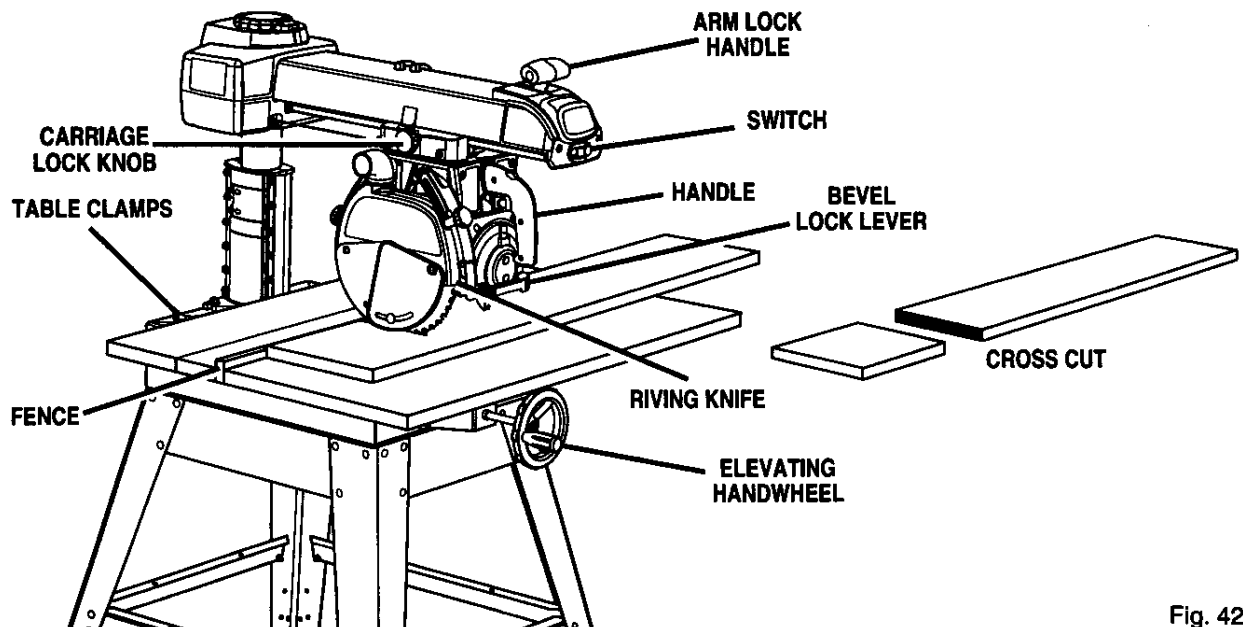

## OPERATION

### MAKING A MITER CUT

See Figure 43.

In a miter cut, the blade is vertical and the arm angled. If a kerf does not exist for the cutting path, make one (instructions below). Each cutting path requires its own kerf.

**WARNING:** Make sure the blade guard is lowered and is working properly to prevent possible injury. Always raise the clear plastic guard before changing the bevel or lowering the blade to avoid damage to the guard.

**WARNING:** Keep one hand on the handle until the blade stops rotating to prevent the risk of injury.

- Put the fence in the front position (next to the front table) and tighten the table clamps.
- Check that the control cut device is set for the correct speed for the type of wood and cut you are planning. Refer to the chart on the label and adjust the thumbwheel on the handle accordingly.
- If the yoke is not in the cross cut position with the blade parallel to the arm, release the yoke lock handle and position the yoke correctly with the yoke pivot latch on the right side of the arm.
- If the arm is too low or too high, first lift the blade guard if the arm is too low, and turn the elevating handwheel at the front of the table. Set the blade to just clear the kerf or table.
- To set the angle of the arm, release the arm lock knob on top of the arm. Use the miter scale above the column to position the arm to the desired angle, and lock the arm lock knob.
- If the blade is angled, raise the plastic lower guard, release the bevel lock lever, and set the bevel indicator to zero. Retighten the bevel lock lever.

- If the blade is in front of the fence, loosen the carriage lock knob on the left side of the arm and let the carriage move back.
- If there is no kerf, cut one approximately 1/16 in. deep. Grasp the handle and turn the saw on with the switch on the arm. Squeeze the switch trigger on the handle and pull the blade forward across the table to make the kerf.
- Release the switch trigger and let the carriage return to the back. Turn the saw off with the switch on the arm but hold the handle until the blade stops rotating. Adjust the height with the elevating handwheel so the blade will rotate freely in the kerf.
- Position the workpiece against the fence. Place the pawls and riving knife to clear the workpiece or the fence, whichever is higher, by at least 1/4 inch.
- Grasp the handle with one hand. With the other, turn the saw on, then hold the workpiece down and against the fence. Keep your hand well away from the blade.
- Squeeze the switch trigger and pull the blade through the workpiece but only far enough to complete the cut. Keep your hand on the handle, even after the cut has been made and the saw turned off, until the blade stops rotating.
- After completing the cut, move the workpiece to the side and turn off the saw with the switch on the arm. Release the switch trigger and let the yoke move back behind the fence. Do not release the handle until the blade stops rotating.

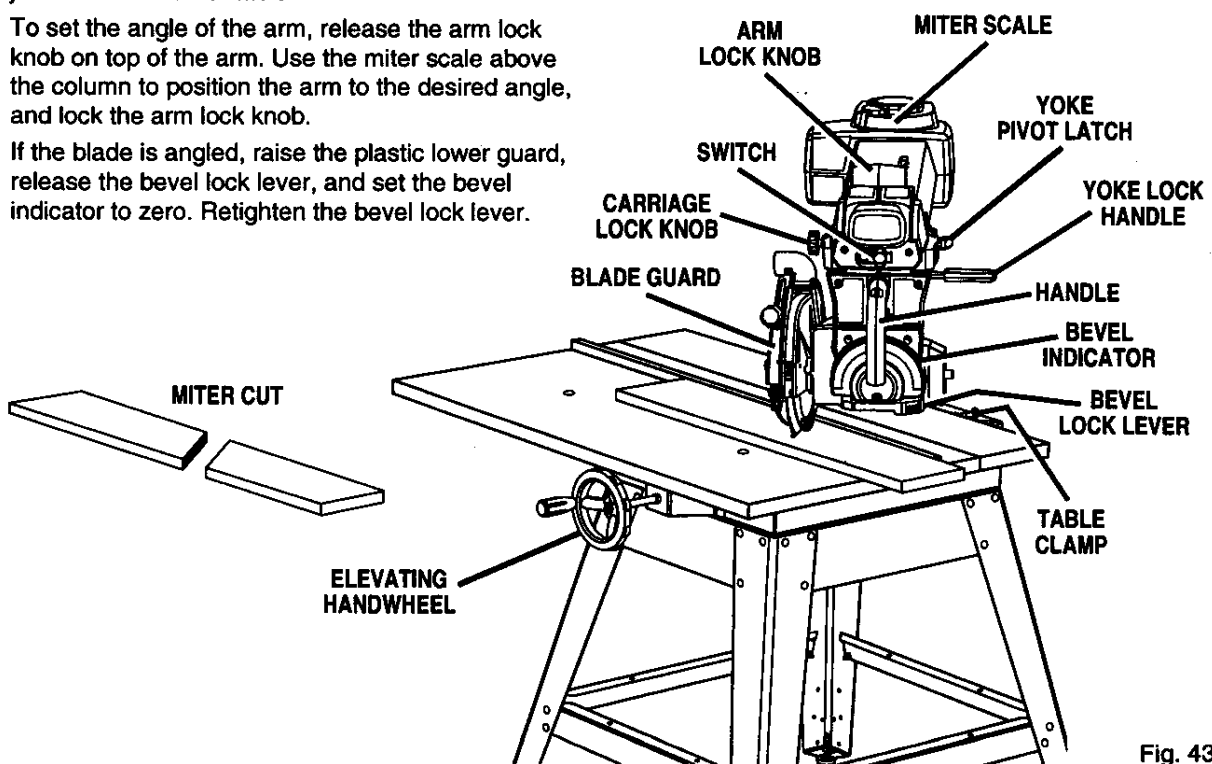

Fig. 43

## OPERATION

### MAKING A BEVEL CUT

See Figure 44.

This procedure makes a cut with the blade and motor angled and the arm straight (90° to fence). If there is no kerf, follow the steps to make one. Try this cut on scrap wood before cutting your workpiece.

**WARNING:** Make sure the blade guard is lowered and is working properly to prevent possible injury. Always raise the clear plastic guard before changing the bevel or lowering the blade to avoid damage to the guard.

**WARNING:** Keep one hand on the handle until the blade stops rotating to prevent the risk of injury.

- Put the fence in the front position (next to the front table) and tighten the table clamps.
  - Check that the control cut device is set for the correct speed for the type of wood and cut you are planning. Refer to the chart on the label and adjust the thumbwheel on the handle accordingly.
  - If the yoke is not in the cross cut position with the blade parallel to the arm, release the yoke lock handle and position the yoke correctly with the yoke pivot latch on the right side of the arm.
  - If the arm is too low or too high, first lift the blade guard if the arm is too low, and turn the elevating handwheel at the front of the table. Set the blade to just clear the kerf or table.
  - If the arm is angled, release the arm lock knob on top of the arm, position it straight ahead and lock the arm lock knob.
  - If the blade is in front of the fence, loosen the carriage lock knob on the left side of the arm. Release the switch trigger on the handle and let the carriage return to the back.
  - To set the blade angle, first raise the plastic lower guard. Release the bevel lock lever, and position the blade with the bevel index lever. Retighten the bevel lock lever.
- Note:** For a 45° or 90° angle, the bevel index lever will seat automatically at the preset positive stop positions. For any other angle, use the bevel lock lever.
- If there is no kerf, cut one approximately 1/16 in. deep. Grasp the handle and turn the saw on with the switch on the arm. Squeeze the switch trigger on the handle and pull the blade forward across the table to make the kerf.
  - Release the switch trigger and let the carriage return to the back. Turn the saw off with the switch on the arm but hold the handle until the blade stops rotating. Adjust the height with the elevating handwheel so the blade will rotate freely in the kerf.
  - Position the workpiece against the fence. Place the pawls and riving knife to clear the workpiece or the fence, whichever is higher, by at least 1/4 inch.
  - Grasp the handle with one hand. With the other hand, turn the saw on, then hold the workpiece down and against the fence. Keep your hand well away from the blade.
  - Squeeze the switch trigger on the handle and pull the blade through the workpiece but only far enough to complete the cut. Keep your hand on the handle, even after the cut has been made and the saw turned off, until the blade stops rotating.
  - After completing the cut, move the workpiece to the side and turn off the saw with the switch on the arm. Release the switch trigger on the handle and let the blade move back behind the fence. Do not release the handle until the blade stops rotating.

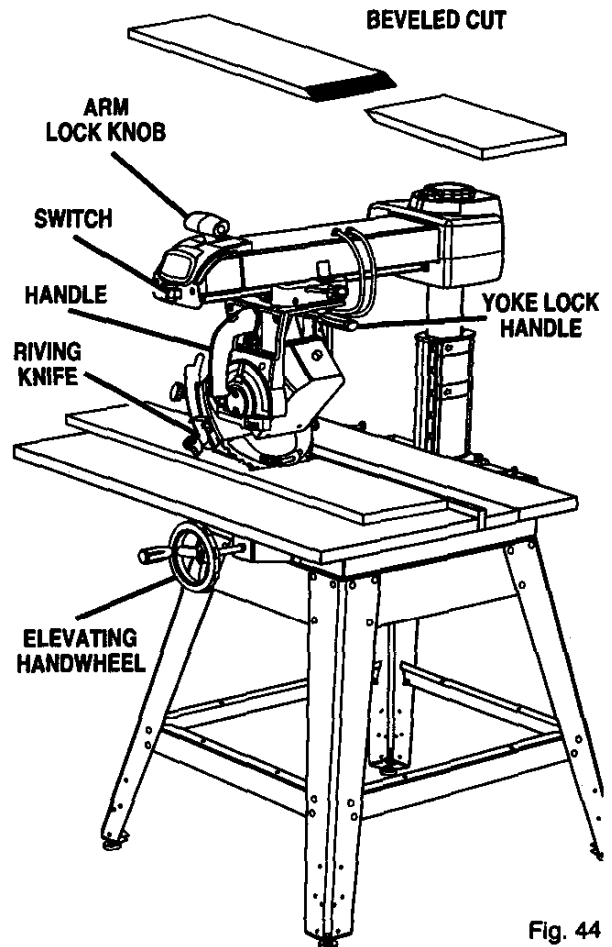

Fig. 44

## OPERATION

### MAKING A COMPOUND CROSS CUT

See Figure 45.

In this cut, both the blade and the arm are angled. Be familiar with both bevel and miter cuts before making a compound cut. Practice on scrap wood.

**⚠ WARNING:** Make sure the blade guard is lowered and is working properly to prevent possible injury. Always raise the clear plastic guard before changing the bevel or lowering the blade to avoid damage to the guard.

**⚠ WARNING:** Keep one hand on the handle until the blade stops rotating to prevent the risk of injury.

- Put the fence in the front position (next to the front table) and tighten the table clamps.
- Check that the control cut device is set for the correct speed for the type of wood and cut you are planning. Refer to the chart on the label and adjust the thumbwheel on the handle accordingly.
- If the yoke is not in the cross cut position with the blade parallel to the arm, release the yoke lock handle and position the yoke correctly with the yoke pivot latch on the right side of the arm.
- If the arm is too low or too high, first lift the blade guard if the arm is too low, and turn the elevating handwheel at the front of the table. Set the blade to just clear the kerf or table.
- To set the angle of the arm, release the arm lock knob on top of the arm. Use the miter scale above the column to position it to the desired angle, and lock the arm lock knob.
- To set the blade angle, first raise the plastic lower guard. Release the bevel lock lever, and position the blade with the bevel index lever.
- Retighten the bevel lock lever.

**Note:** For a 45° or 90° angle, the bevel index lever will seat automatically at the preset positive stop positions. For any other angle, use the bevel lock lever.

- If the yoke is in front of the fence, loosen the carriage lock knob on the left side of the arm. Release the switch trigger on the handle and let the carriage return to the back.
- If there is no kerf, cut one approximately 1/16 in. deep. Grasp the handle. Turn the saw on with the switch on the arm. Squeeze the switch trigger and pull the blade forward to make the kerf.
- Release the switch trigger and let the carriage return to the back. Turn the saw off with the switch on the arm but hold the handle until the blade stops rotating. Adjust the height with the elevating handwheel so the blade will rotate freely in the kerf.
- Position the workpiece against the fence. Place the pawls and riving knife to clear the workpiece or the fence, whichever is higher, by at least 1/4 inch.
- Grasp the handle with one hand. With the other hand, turn the saw on, then hold the workpiece down and against the fence. If necessary, slightly raise the outer blade guard for clearance. Keep your hand well away from the blade.
- Squeeze the switch trigger and pull the blade through the workpiece but only far enough to complete the cut. Keep your hand on the handle, even after the cut has been made and the saw turned off, until the blade stops rotating.
- After completing the cut, move the workpiece to the side and turn off the saw with the switch on the arm. Release the switch trigger and let the yoke move back behind the fence. Do not release the handle until the blade stops rotating.

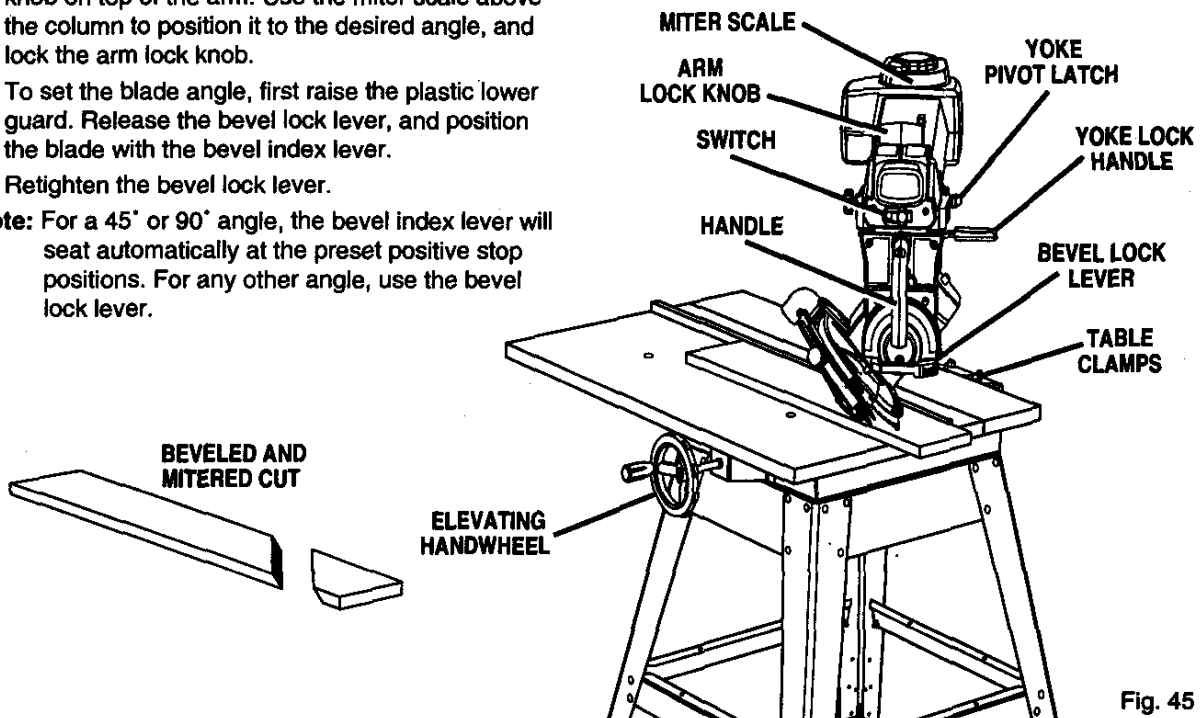

Fig. 45

## OPERATION

### RIP CUT HAZARDS AND PRECAUTIONS

Two hazards are specifically associated with rip cutting: outfeed zone and wrong way feed.

In the outfeed zone (behind the blade), the blade teeth point down. The slightest contact while the blade is still spinning can snag clothing, jewelry, the workpiece, or even skin, causing serious personal injury.

Wrong way feed occurs when the workpiece contacts the blade from the outfeed side. It is very hazardous and will jerk the workpiece violently. You could be cut if you are holding the workpiece.

**⚠ WARNING:** Failure to observe any of these precautions can result in serious injury.

- The first precaution is, of course, simply to stay completely away from the outfeed zone. Keep hands away from the outfeed zone.
- Point the anti-kickback pawls away from the blade teeth to snag a workpiece if the blade grabs. They should be positioned to rest lightly on the workpiece. The flat side of the pawls should be level and horizontal.
- Set the riving knife to just clear the table.
- Set the hold down in front of the blade to just clear the workpiece.
- Start and finish your cut from the infeed side.
- Push the workpiece past the pawls with pushblocks and pushsticks to finish the cut.
- If the blade jams, turn the saw off with the switch on the arm, remove the yellow key, and wait for the blade to fully stop before freeing it.
- Make sure the blade is parallel to the fence and the workpiece is not warped or twisted.
- Make sure no pressure is applied to the workpiece on the outfeed side.
- Make sure the blade guard is lowered and is working properly.
- Always set up the workpiece so the wider part of the wood is between the blade and the fence. This stabilizes the workpiece better.
- Do not release the workpiece until it has moved past the pawls. Keep pushsticks firmly in place.
- Use pushsticks and pushblocks, not your hands, when the trailing edge of the workpiece is within 3 in. of the blade. If the blade is set 2 in. or more from the fence, use a pushstick. Use a pushblock and auxiliary fence when the blade is between 2 in. and 1/2 in. from the fence. (If the cut is narrower than 1/2 in., use a different saw.) For large panel rip cuts, use a featherboard instead of pushblocks or pushsticks. See the section on *Cutting Aids*.

### SETTING UP A RIP CUT

See Figure 46.

A precise and safe rip cut requires a careful set up. Before setting up for in-rip or out-rip, especially for a bevel cut, try the workpiece in both placements. Check for stability, visibility, and control. Test which will give the best pushstick clearance.

Instructions are given for an in-rip cut. At certain points, the instructions will vary for a bevel rip cut or an out-rip process and will be enclosed in parentheses (example). Figure 47 shows an out-rip setup.

- Insert a solid fence with no kerfs. Use an auxiliary fence if the blade will be set only 1/2 in. to 2 in. from the fence. Tighten the table clamps.
- If the arm is too low or too high, first lift the blade guard if the arm is too low, and turn the elevating handwheel at the front of the table. Set the blade to just clear the kerf or table.
- Change the blade angle if needed. Raise the plastic lower guard to keep it from jamming, release the bevel lock lever, and set the bevel indicator to zero. (For a bevel rip cut, set the bevel indicator to the desired angle.) Test the clearance on the guard. Retighten the bevel lock lever.

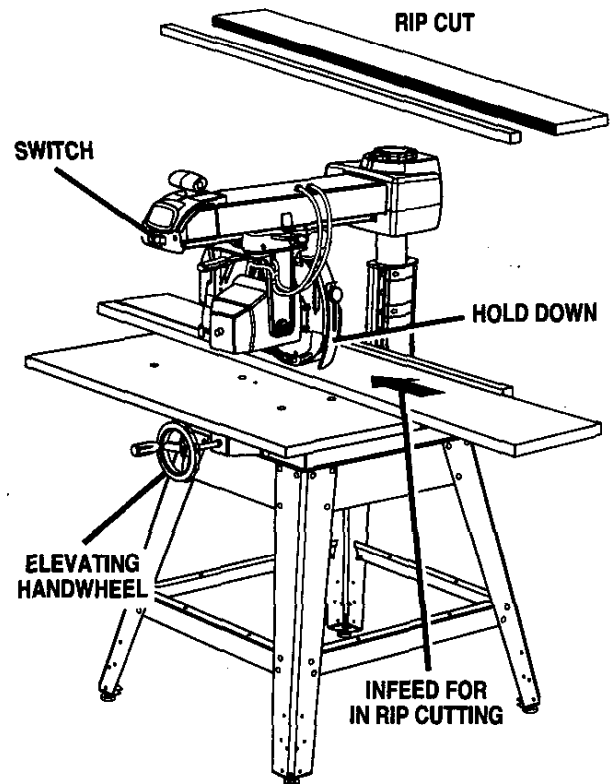

Fig. 46

## OPERATION

- Put the blade in the in-rip position between the motor and the column. Release the yoke lock handle and pivot the yoke to the left, with the yoke pivot latch on the right side of the arm. **(Use the out-rip position only for rips 12 in. or more in width; pivot the yoke to the right so the motor is between the blade and column.)**
- Loosen the carriage lock knob. Place the blade the right distance from the fence for the cut and lock the knob.
- Cut a kerf. Turn the saw on with the switch on the arm. Lower the blade about 1/16 in. into the table to cut a shallow groove. Turn the saw off and remove the yellow key.
- Position the workpiece against the blade, from the front of the table. Lower the hold-down in front of the blade to just clear the workpiece. **(For a bevel rip cut, place the workpiece directly under the guard rather than beside the blade.)**
- Loosen the pawls and riving knife. Lower the riving knife to the table. Slide the workpiece back and lower the pawls so that one set rests on the workpiece. Lock the riving knife and pawls in place. **(For a bevel rip cut, place the workpiece under the lower set of pawls.)**
- Remove the workpiece from the table. Set the push block, featherboard, or pushstick nearby.
- Set up table extension(s) and supports.

**⚠ WARNING:** Never use a person to support workpieces. This can cause kickback and serious injury. Never have someone stand at the outfeed side.

### MAKING A RIP CUT

See Figure 47.

- Review the *Hazards and Precautions* page.
- Do not make a rip cut without following all the setup steps in the previous procedure.
- After the saw has been set up, insert the yellow key, and turn the saw on with the switch on the arm. Let the blade build up to full speed.
- Stand at the infeed side of the blade and out of the line of the workpiece, in case kickback occurs.

**⚠ WARNING:** Never stand directly in the line of cut. Stand to the side to reduce the chance of injury should kickback occur. Start and finish the cut from the infeed side.

- With the hand closest to the fence, push the workpiece under the hold down and into the blade.

- Keep your other hand on the table and steady the workpiece against the fence. Keep that hand at least 8 in. from the blade.
- If the blade cover does not automatically rise as the workpiece moves from the infeed to the outfeed side, stop the cut. Turn off the saw and adjust the blade cover so it rests on the workpiece.
- When the end of the workpiece is still several inches from the blade, pick up the cutting aid you selected earlier. Push the wood with the pushstick or pushblock rather than your hand.

**⚠ WARNING:** Use a pushstick as the end of the workpiece nears the blade to reduce the risk of injury.

- Push the wood completely through the blade to the outfeed, past the pawls.
- When the work is completed, press the switch off and remove the key.

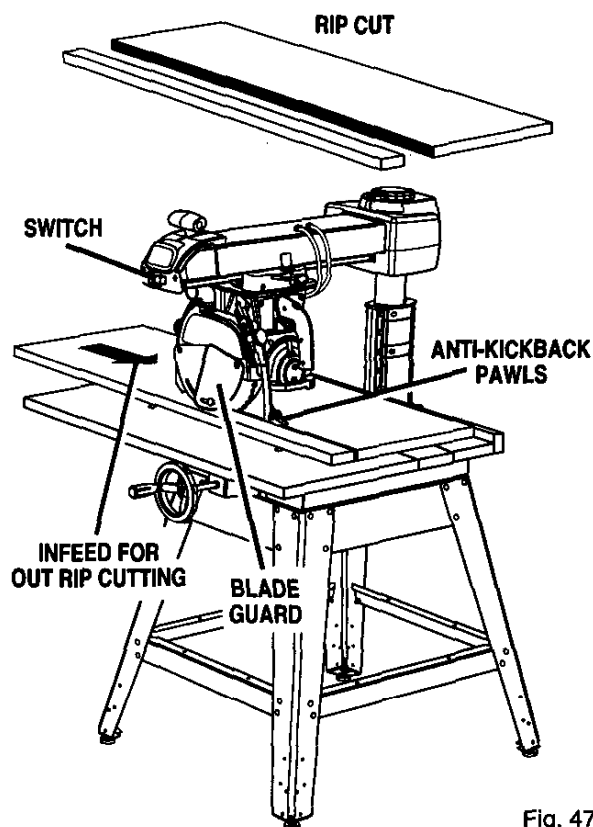

Fig. 47

## OPERATION

### MAKING OTHER CUTS

See Figures 48 and 49.

Variations from the basic cuts include cutting long workpieces and non-through cuts.

When making one of the following cuts, follow the instructions that apply for the basic cut, depending on the position, shape, and size of the wood. Do not attempt these cuts until you are skilled with the basic cuts.

### CUTTING LONG WORKPIECES

See Figure 48.

- Place a support the same height as the saw table nearby for the cut work.

**⚠ WARNING:** Make sure the blade guard is lowered and is working properly to prevent possible injury.

**⚠ WARNING:** Never put your hands within 3 in. of the blade when it is on.

■ Make sure the wood does not touch the blade before you turn on the saw with the switch on the arm. Let the blade build up to full speed before it contacts the wood.

■ When the work is completed, press the switch off and remove the key.

### SUPPORT LONG WORKPIECES

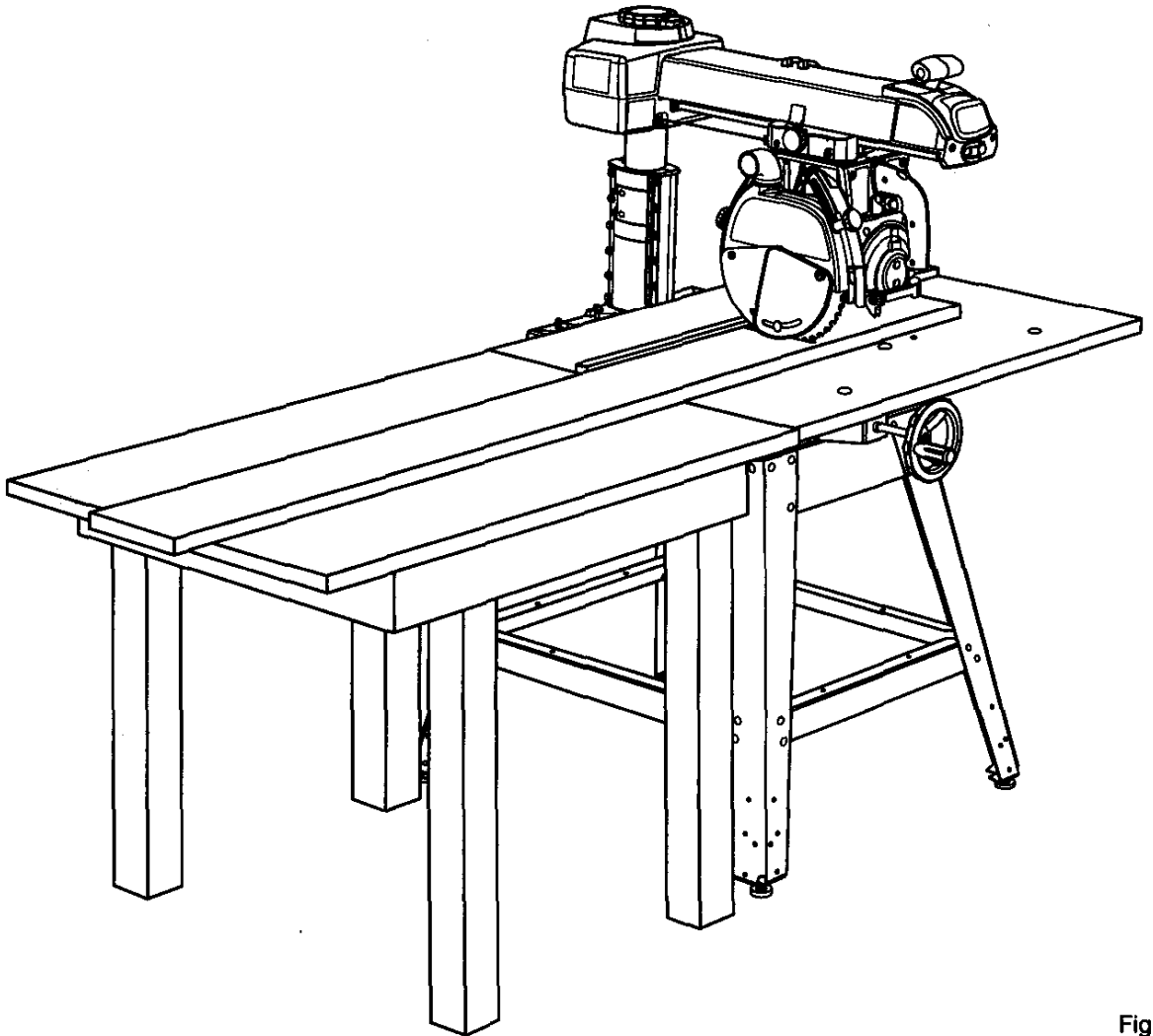

Fig. 48

## OPERATION

### NON-THROUGH CUTS

See Figure 49.

**⚠ WARNING:** Unplug the saw while removing or replacing the blade guard. Turn on the saw with the switch on the arm to confirm the blade is not receiving power.

- Remove the blade and blade guard (see *Assembly* section).
- Place a support the same height as the saw table nearby for the cut work. Lower the blade with the elevating handwheel.
- Make sure the wood is not touching the blade. Insert the key and turn on the saw. Let the blade build up to full speed before contacting the work-piece.

**⚠ WARNING:** Always use pushblocks when making non-through rip cuts to avoid the risk of serious injury. Never feed wood with your hands.

- When the work is completed, press the switch off and remove the key.

### NON-THROUGH CUT

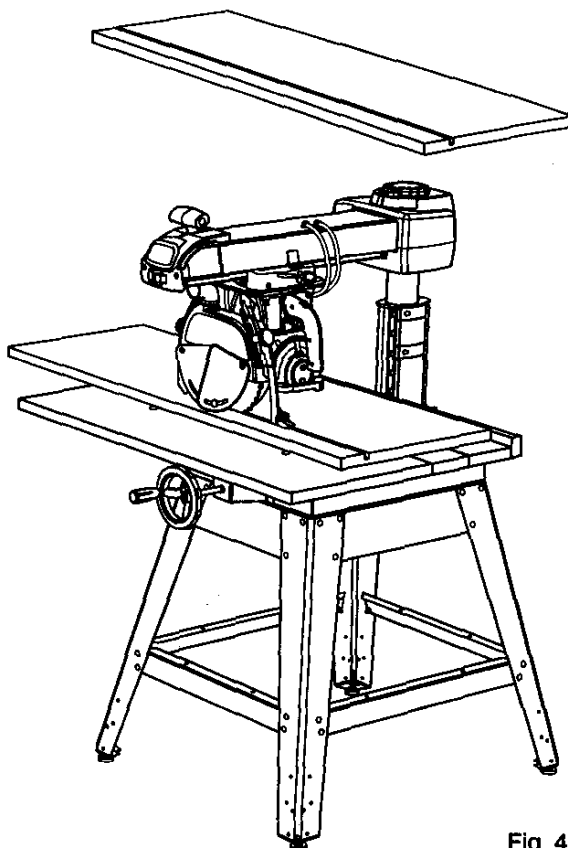

Fig. 49



### Control Cut Settings

Crosscut		
Wood Type	Setting Position	Feet Minute
Hard	A	0-6
Medium	B	0-20
Soft	C	0-35
Bevel Crosscut		
Wood Type	Setting Position	Feet Minute
All Types	A	0-6



Miter Crosscut		
Wood Type	Setting Position	Feet Minute
Hard	A	0-6
Medium	B	0-20
Soft	C	0-35
Compound Crosscut		
Wood Type	Setting Position	Feet Minute
All Types	A	0-6

## MAINTENANCE

### GENERAL MAINTENANCE

-  **WARNING:** When servicing, use only identical Craftsman replacement parts. Use of any other part may create a hazard or cause product damage.
-  **WARNING:** To prevent accidental starting that could cause possible serious personal injury, turn off the saw with the switch on the arm, remove the switch key, and unplug the saw before working on the radial saw.
- Remove sawdust from the work area, including inside the blade cover, frequently.
- Remove sawdust from and clean the blade guards frequently.
- Clean plastic parts with a soft damp cloth. Do not use any strong solvents.
-  **WARNING:** Do not at any time let brake fluids, gasoline, petroleum-based products, penetrating oils, etc. contact plastic parts. They contain chemicals that can damage, weaken or destroy plastic.
- Check teeth of anti-kickback pawls; sharpen with file if needed.
- Regularly check all nuts, bolts, screws, and cables for tightness and condition.

### MOTOR/ELECTRICAL

- Frequently vacuum or blow out any sawdust from the work areas.
-  **WARNING:** If the power cords are worn, cut, or damaged in any way, have them replaced immediately by a qualified service technician at a Sears store or repair center. Failure to do so could result in serious personal injury.
-  **WARNING:** To avoid fire or electrocution, reassemble electric parts only with identical Craftsman replacement parts. Reassemble exactly as originally assembled.

## TROUBLESHOOTING

PROBLEM	CAUSE	SOLUTION
Saw does not start.	1. Motor cord or control-cut cord is not plugged in.	1. Plug in cord.
	2. Cord or switch is damaged.	2. Have the cord or switch replaced at your nearest Sears Service Center.
	3. Circuit fuse is blown.	3. Replace circuit fuse.
	4. Circuit breaker is tripped.	4. Reset circuit breaker.
	5. Switch is burned out.	5. Have the switch replaced and request a voltage check from the power company.
	6. Connections are loose, burned out, or damaged.	6. Have the wiring checked and repaired. Request voltage check from power company.
Motor does not reach full speed or power.	1. Voltage from source is low.	1. Request a voltage check from the power company.
	2. Circuit is overloaded with other appliances or motors.	2. Test without any other motors and on different circuit.
	3. Motor windings are burned out.	3. Have the windings replaced and request a voltage check from the power company.
	4. Fuses or circuit breakers are wrong size.	4. Have an electrician replace with a 15 amp fuse or circuit breaker.
	5. Extension cord is too long.	5. Use a shorter cord.
	6. Starter switch is defective.	6. Have the switch replaced.
Motor stalls, blows fuses, or trips circuit breakers.	1. Starter switch is defective.	1. Have the switch replaced.
	2. Voltage from source is low.	2. Request a voltage check from the power company.
	3. Fuses or circuit breakers are wrong size or defective.	3. Have an electrician replace with a 15 amp fuse or circuit breaker.
Motor overheats.	1. Motor is overloaded.	1. Request a voltage check from the power company.
	2. Windings are burned out.	2. Have the windings replaced and request a voltage check from the power company.
	3. Work is being fed too fast.	3. Feed work slower.

## TROUBLESHOOTING

PROBLEM	CAUSE	SOLUTION
Saw vibrates excessively.	1. Blade is warped.	1. Replace the blade. See the removal procedure in <i>Assembly</i> section.
	2. Saw is not mounted securely.	2. Tighten all hardware.
	3. Work surface is uneven.	3. Reposition on a flat surface. Adjust the leveling feet on legs.
Saw is noisy when running.	1. Motor needs attention.	1. Have the motor checked at your nearest Sears Service Center.
Carriage does not travel smoothly in track under arm.	1. Track is dirty or sticky.	1. Clean track. See <i>Installing Carriage Assembly</i> in <i>Assembly</i> section.
	2. Carriage bearings are bad.	2. Replace carriage bearings. Contact your nearest Sears service center.
	3. Blade or teeth are dull or bent.	3. Sharpen or replace the blade. See the removal procedure in <i>Assembly</i> section.
	4. Blade is out of alignment.	4. Use blade alignment procedures in <i>Adjustment</i> section.
	5. Board is warped.	5. Replace the board.
Saw stalls when ripping.	1. Blade or teeth are dull or bent.	1. Sharpen or replace the blade. See the removal procedure in <i>Assembly</i> section.
	2. Fence is not straight.	2. Check with square; sand or replace.
	3. Work is being fed too fast.	3. Feed work into blade slower.
	4. Wrong blade is being used.	4. Change the blade.
	5. Column tube is too loose in the column support.	5. See <i>Adjusting the Column Tube</i> in <i>Assembly</i> section.
	6. Arm is misaligned or loose.	6. See <i>Setting the Arm Lock Wheel</i> in the <i>Assembly</i> section.
	7. Yoke is loose on carriage.	7. See <i>Setting the Yoke Clamp</i> procedure in <i>Assembly</i> section.
	8. Sawdust has accumulated between tables.	8. Remove and clean tables.

## TROUBLESHOOTING

PROBLEM	CAUSE	SOLUTION
Handwheel is hard to turn or column binds.	1. Sawdust has collected on the elevating shaft.	1. Remove handwheel; clean and lubricate the shaft.
	2. Column is out of alignment.	2. See <i>Adjusting the Column Tube</i> in <i>Assembly</i> section.
Saw burns or scores edges of wood in cut.	1. Column tube is too loose in the column support.	1. See <i>Adjusting the Column Tube</i> in <i>Assembly</i> section.
	2. Blade or teeth are bent or dull.	2. Sharpen or replace the blade. See the removal procedure in <i>Assembly</i> section.
	3. Blade is out of alignment.	3. Use blade alignment procedures in <i>Adjustment</i> section.
	4. Wrong blade is being used.	4. Change blade. See the removal procedure in <i>Assembly</i> section.
	5. Board is warped.	5. Replace the board.
	6. Arm is loose or misaligned.	6. See <i>Setting the Arm Lock Wheel</i> in the <i>Assembly</i> section.
	7. Yoke is loose on carriage.	7. See <i>Setting the Yoke Clamp</i> procedure in <i>Assembly</i> section.
	8. Arm is out of alignment.	8. See <i>Aligning Arm for Cross Cuts</i> in <i>Adjustments</i> section.
	9. Work is being fed too fast.	9. Feed work into blade slower.
Bevel cuts are not true.	1. Bevel lock lever is loose.	1. See <i>Setting the Bevel Lock Lever</i> in <i>Assembly</i> section.
	2. Blade is not perpendicular to table top.	2. See <i>Aligning the Blade to the Table</i> in <i>Adjustments</i> section.
	3. Column tube is too loose in the column support.	3. See <i>Adjusting the Column Tube</i> in <i>Assembly</i> section.
	4. Table top is not parallel to the arm.	4. See <i>Leveling Table Supports and Leveling the Front Table</i> in the <i>Assembly</i> section.
	5. Yoke is loose on carriage.	5. See <i>Setting the Yoke Clamp</i> procedure in <i>Assembly</i> section.
	6. Arm is out of alignment.	6. See <i>Aligning Arm for Cross Cuts</i> in <i>Adjustments</i> section.

## TROUBLESHOOTING

PROBLEM	CAUSE	SOLUTION
Miter or cross cuts are not true.	1. Scale pointer is not correct.	1. Reset the pointer at the top rear of arm.
	2. Column is out of alignment.	2. See <i>Adjusting the Column Tube</i> in <i>Assembly</i> section.
	3. Carriage is misaligned.	3. See <i>Setting the Arm Lock Wheel</i> in the <i>Assembly</i> section.
	4. Yoke is loose on carriage.	4. See <i>Setting the Yoke Clamp</i> procedure in <i>Assembly</i> section.
	5. Arm is out of alignment.	5. See <i>Aligning Arm for Cross Cuts</i> in <i>Adjustments</i> section.
	6. Sawdust has collected between tables.	6. Remove and clean tables.
	7. Table top is not parallel to the arm.	7. See <i>Leveling Table Supports and Leveling the Front Table</i> in the <i>Assembly</i> section.
	8. Fence/tables are not straight.	8. Check with square; sand or replace.
Wood edges away from fence when ripping.	1. Blade is not parallel with fence.	1. See <i>Squaring the Blade to the Fence</i> procedure in the <i>Adjustments</i> section.
	2. Arm is not perpendicular to fence.	2. See <i>Aligning the Arm for Cross Cuts</i> procedure in the <i>Adjustments</i> section.
	3. Riving knife needs adjustment.	3. See <i>Aligning the Riving Knife to the Blade</i> procedure in the <i>Adjustments</i> section.
Depth of cut varies from one end of wood to the other.	1. Table is not parallel to arm.	1. See <i>Leveling Table Supports and Leveling the Front Table</i> in the <i>Assembly</i> section.
	2. Column tube is loose in column support.	2. See <i>Adjusting the Column Tube</i> in <i>Assembly</i> section.
	3. Arm is loose or misaligned.	3. See <i>Setting the Arm Lock Wheel</i> in the <i>Assembly</i> section.
Riving knife strikes wood during a cut.	1. Riving knife not aligned with blade.	1. See <i>Aligning the Riving Knife to the Blade</i> procedure in the <i>Adjustments</i> section.

## TROUBLESHOOTING

PROBLEM	CAUSE	SOLUTION
Saw blade tends to push wood to one side when cross cutting.	1. Blade is heeling.	1. See <i>Squaring the Blade to the Fence</i> in <i>Adjustments</i> section.
	2. Column tube is loose in column support.	2. See <i>Adjusting the Column Tube</i> in <i>Assembly</i> section.
	3. Arm is loose or misaligned.	3. See <i>Setting the Arm Lock Wheel</i> in the <i>Assembly</i> section.
	4. Fence/tables are not straight.	4. Check with square; sand or replace.
	5. Blade or teeth are bent or dull.	5. Sharpen or replace the blade. See the removal procedure in <i>Assembly</i> section.

## NOTES

**CRAFTSMAN RADIAL ARM SAW – MODEL NO. 315.220381**

The model number will be found on a plate attached to the base. Always mention the model number in all correspondence regarding your **RADIAL ARM SAW** or when ordering repair parts.

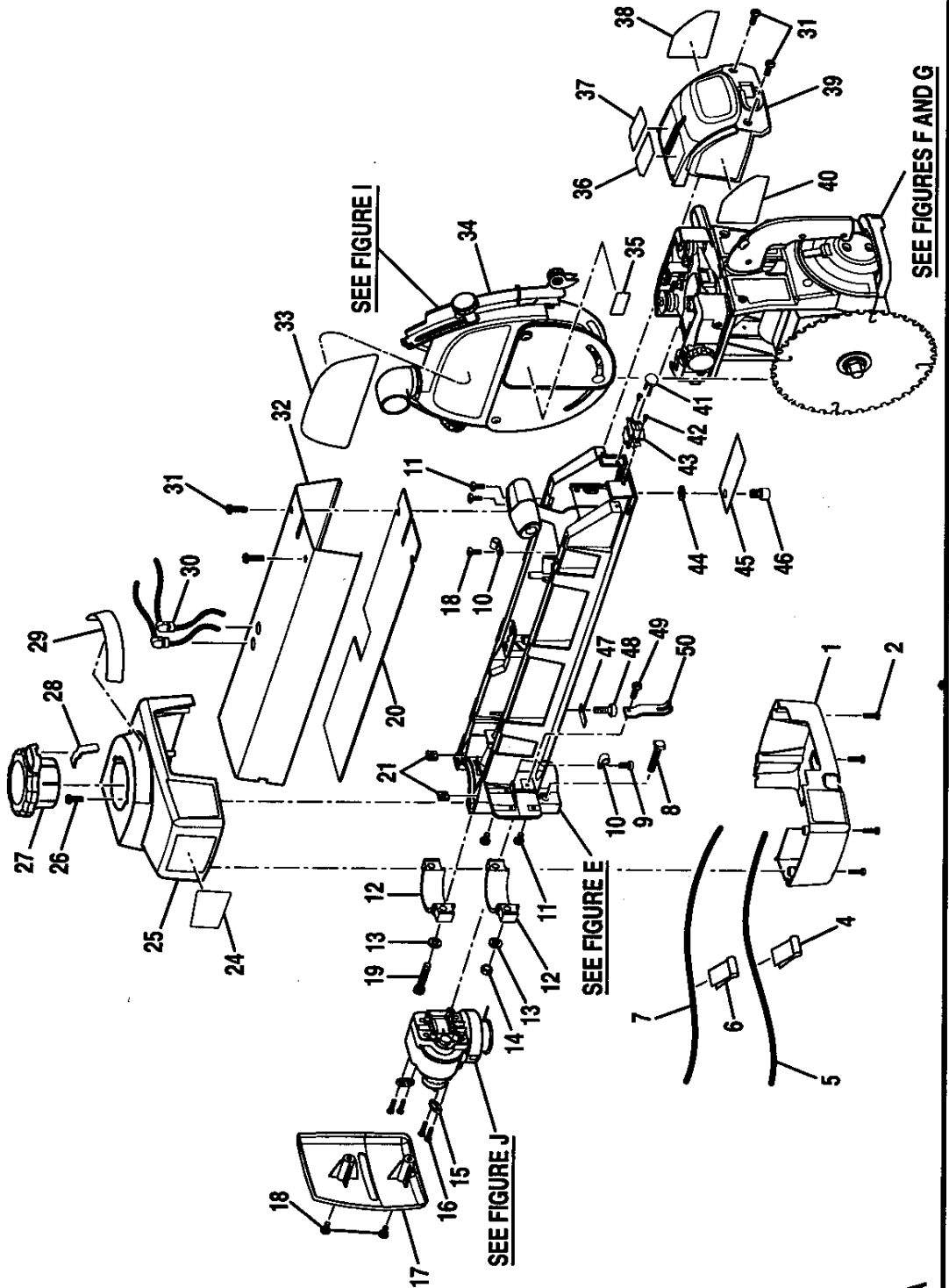

**FIGURE A**

**PARTS LIST FOR FIGURE A**

KEY NO.	PART NUMBER	DESCRIPTION	QUAN.	KEY NO.	PART NUMBER	DESCRIPTION	QUAN.
1	976830-001	Lower Arm Cover .....	1	28	976354-001	Miter Indicator .....	1
2	** STD611006	* Screw (10-16 x 5/8 in. Pan Hd.) .....	4	29	980532-001	Miter Scale Label .....	1
4	980667-001	Cord Label (Control Cut Power Cord) .....	1	30	980447-001	Strain Relief .....	2
5	976793-001	Control Cut Power Cord .....	1	31	641700-008	* Screw (10-32 x 5/8 in. Pan Hd.) .....	4
6	980669-001	Cord Label (Motor Power Cord) .....	1	32	976327-002	Arm Cover .....	1
7	976786-001	Motor Power Cord .....	1	33	980550-001	Guard Label .....	1
8	976834-002	* Bolt (3/8-16 x 2-1/4 in. Sq. Hd.) .....	2	34	976393-001	Guard Assembly .....	1
9	** STD511103	* Screw (10-32 x 3/8 in. Pan Hd.) .....	1	35	980697-001	Guard Warning Label .....	1
10	989001-002	Cable Clamp .....	2	36	981241-001	Warning Label .....	1
11	** STD600803	* Screw (8-32 x 3/8 in. Pan Hd. T. C.) .....	4	37	980542-001	Miter Lock Label .....	1
12	976342-001	Arm Bearing .....	2	38	980544-001	Warning Label (Right Side) .....	1
13	703776-098	Washer .....	4	39	976331-001	Arm Cap .....	1
14	** STD541437	* Lock Nut (3/8-16) .....	2	40	980546-001	Warning Label (Left Side) .....	1
15	967917-001	Cord Clamp .....	2	41	976863-001	Switch Key .....	1
16	990908-009	* Screw (6-19 x 5/8 in. Pan Hd.) .....	4	42	** STD510803	* Screw (8-32 x 3/8 in. Pan Hd.) .....	1
17	976384-001	Rear Cover .....	1	43	976862-002	Switch .....	1
18	** STD511103	* Screw (10-32 x 3/8 in. Pan Hd.) .....	3	44	** STD551131	Lock Washer .....	1
19	621380-007	* Screw (3/8-16 x 2-1/8 in. Hex Hd. Locking) ..	2	45	977471-001	Tag .....	1
20	976328-001	Arm Cover Pad .....	1	46	969220-005	* Screw (5/16-18 x 3/8 in. Socket Hd.) .....	1
21	624282-003	Square Nut (3/8-16) .....	2	47	976368-001	Cord Clamp .....	1
24	980534-001	Control Cut Warning .....	1	48	** STD512505	* Screw (1/4-20 x 1/2 in. Pan Hd.) .....	1
25	976829-001	Upper Arm Cover .....	1	49	642409-002	* Screw (10-16 x 41/64 in. Pan Hd.) .....	4
26	** STD511105	* Screw (10-32 x 1/2 in. Pan Hd.) .....	2	50	976369-001	Cable Bracket .....	1
27	976344-001	Miter Cap .....	1				

\* Standard Hardware Item — May Be Purchased Locally  
 \*\* Available From Div. 98 — Source 980.00

# CRAFTSMAN RADIAL ARM SAW – MODEL NO. 315.220381

The model number will be found on a plate attached to the base. Always mention the model number in all correspondence regarding your **RADIAL ARM SAW** or when ordering repair parts.

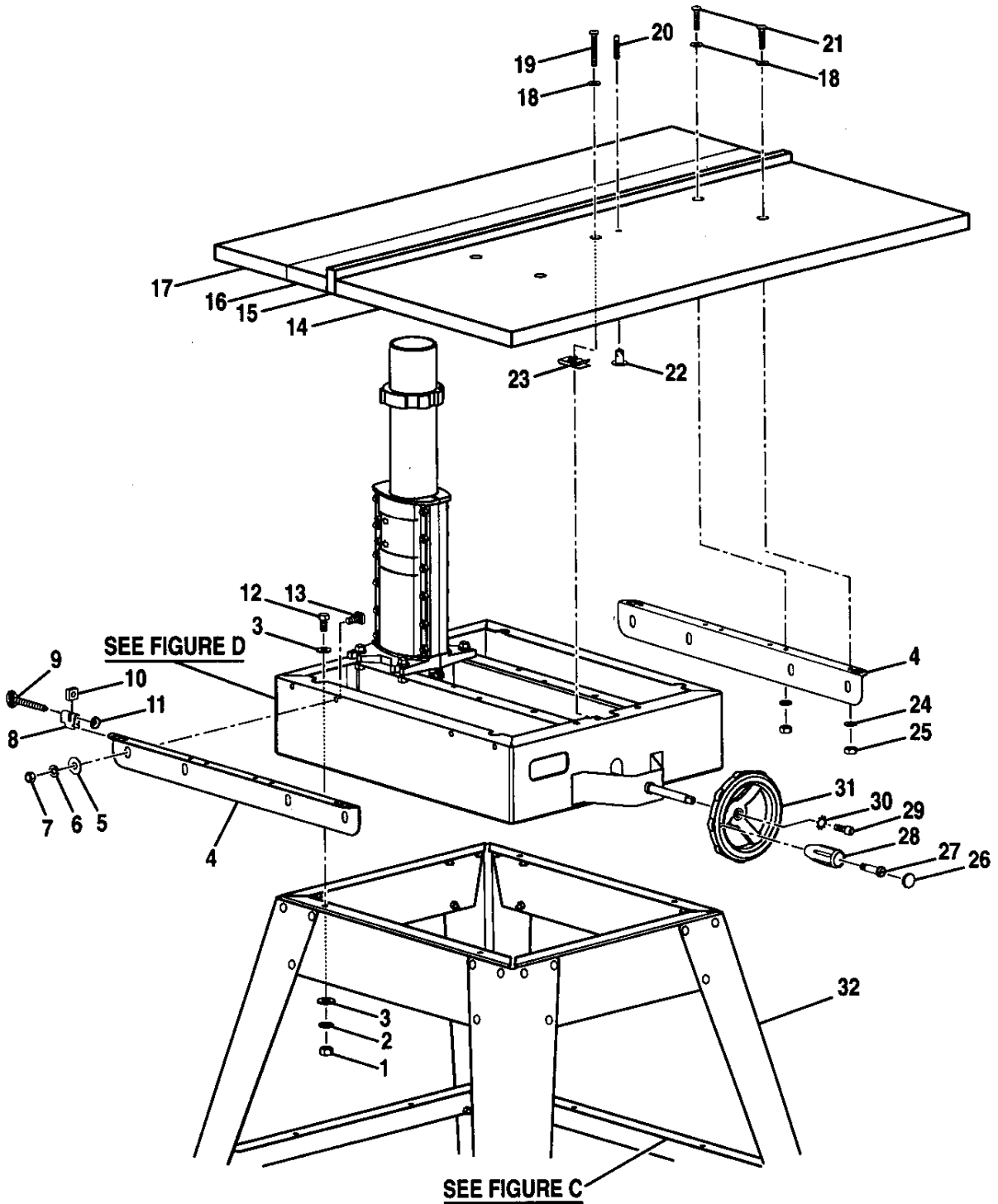

FIGURE B

## CRAFTSMAN RADIAL ARM SAW – MODEL NO. 315.220381

The model number will be found on a plate attached to the base. Always mention the model number in all correspondence regarding your **RADIAL ARM SAW** or when ordering repair parts.

### PARTS LIST FOR FIGURE B

KEY NO.	PART NUMBER	DESCRIPTION	QUAN.
1	** STD541031	* Hex Nut (5/16-18) .....	4
2	** STD551131	* Lock Washer (5/16).....	4
3	624088-002	Washer.....	8
4	976698-001	Table Support.....	2
5	931275-028	Washer.....	4
6	** STD551131	* Lock Washer (5/16).....	4
7	** STD541031	* Hex Nut (5/16-18) .....	4
8	976339-001	Clamp Bracket .....	2
9	976340-001	Clamp Screw .....	2
10	624282-002	Square Nut.....	2
11	977249-001	Cup Washer (Table Clamp).....	2
12	** STD523106	* Bolt (5/16-18 x 5/8 in. Hex Hd.) .....	4
13	976834-001	* Bolt (5/16-18 x 3/4 in. Sq. Hd.) .....	4
14	976335-001	Front Table .....	1
15	976334-001	Fence .....	1
16	976333-001	Spacer Table .....	1
17	976332-001	Rear Table .....	1
18	931744-059	Washer.....	5
19	607737-004	* Screw (1/4-20 x 1-3/4 in. Pan Hd.) .....	1
20	989594-003	* Setscrew (1/4-20 x 1-1/4 in.).....	1
21	** STD512510	* Screw (1/4-20 x 1 in. Pan Hd.).....	4
22	976791-001	Tee Nut .....	1
23	976792-001	"U" Clip Nut .....	1
24	703473-089	Lock Washer .....	4
25	** STD541025	* Hex Nut (1/4-20) .....	4
26	977481-001	Handle Cap .....	1
27	977491-001	Screw (M8 x 1-1/4 in. Pan Hd. Slotted) .....	1
28	977229-001	Handle .....	1
29	940021-008	* Screw (10-24 x 5/8 in. Soc. Hd.).....	1
30	621032-002	Star Washer .....	1
31	977227-001	Handwheel Assembly (Includes Key Nos. 26, 27, 28) .....	1
32	976361-000	Leg Stand Assembly .....	1
	972000-705	Owner's Manual (Not Shown)	

\* Standard Hardware Item — May Be Purchased Locally

\*\* Available From Div. 98 — Source 980.00

**CRAFTSMAN RADIAL ARM SAW — MODEL NO. 315.220381**

The model number will be found on a plate attached to the base. Always mention the model number in all correspondence regarding your RADIAL ARM SAW or when ordering repair parts.

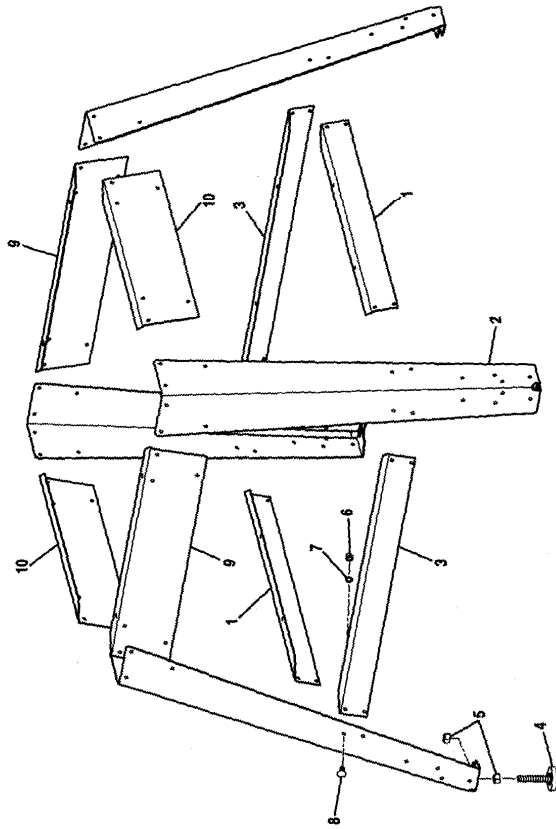

FIGURE C

The model number will be found on a plate attached to the base. Always mention the model number in all correspondence regarding your **RADIAL ARM SAW** or when ordering repair parts.

**PARTS LIST FOR FIGURE C**

KEY NO.	PART NUMBER	DESCRIPTION	QUAN.
1	977242-001	Lower Front/Rear Brace .....	2
2	976303-001	Leg .....	4
3	977241-001	Lower Side Brace .....	2
4	976306-001	Leveling Foot .....	4
5	** STD541037	* Hex Nut (3/8-16) .....	8
6	** STD541025	* Hex Nut (1/4-20) .....	40
7	621032-010	Star Washer .....	40
8	977479-001	* Screw (1/4-20 x 5/8 in. Truss Hd.) .....	40
9	976304-001	Side Brace .....	2
10	976305-001	Front/Rear Brace .....	2
	976361-000	Complete Leg Stand Assembly (Includes Items Listed Above)	2

\* Standard Hardware Item — May Be Purchased Locally  
 \*\* Available From Div. 98 — Source 980.00

# CRAFTSMAN RADIAL ARM SAW – MODEL NO. 315.220381

The model number will be found on a plate attached to the base. Always mention the model number in all correspondence regarding your **RADIAL ARM SAW** or when ordering repair parts.

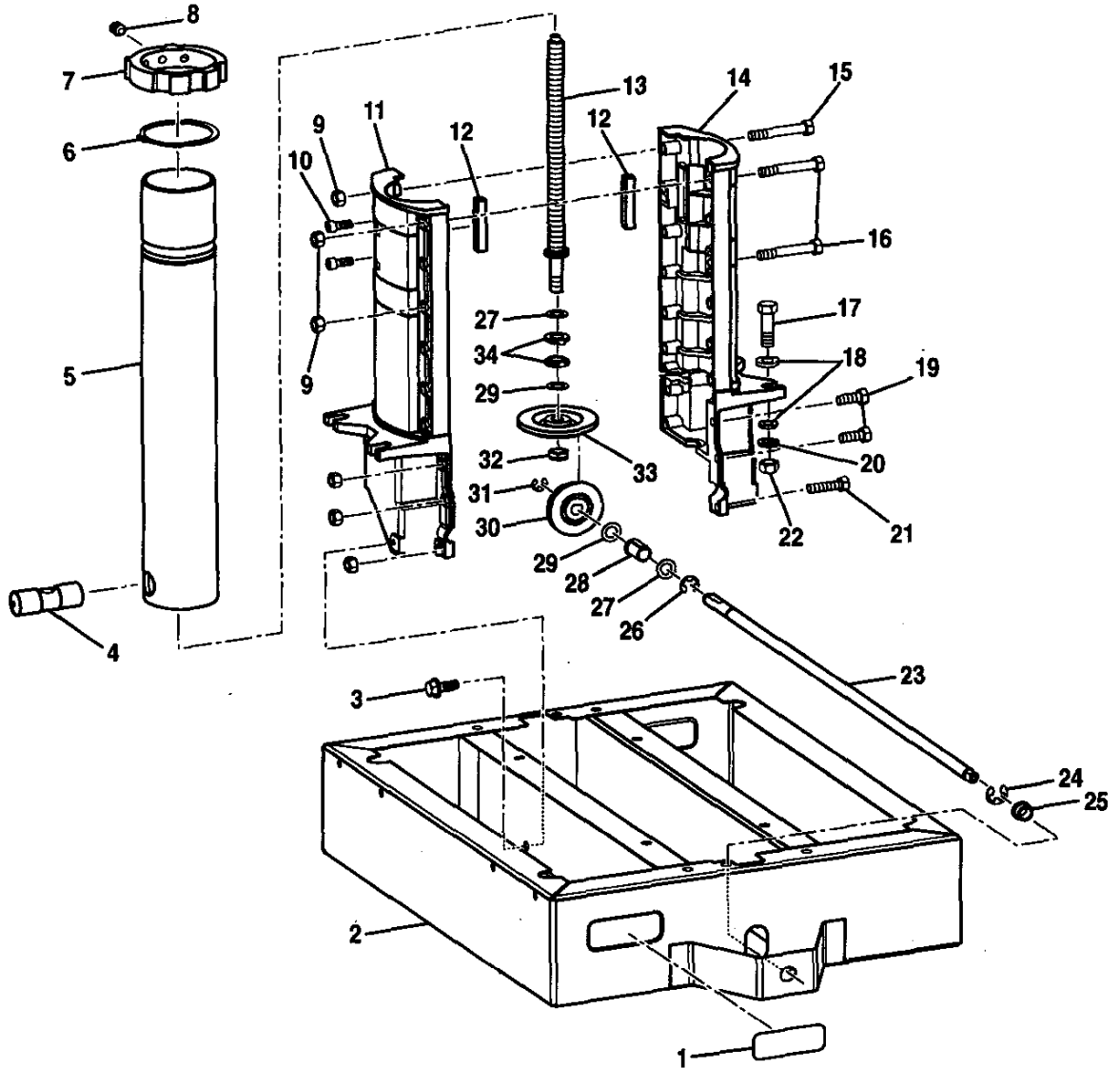

FIGURE D

## CRAFTSMAN RADIAL ARM SAW – MODEL NO. 315.220381

The model number will be found on a plate attached to the base. Always mention the model number in all correspondence regarding your **RADIAL ARM SAW** or when ordering repair parts.

### PARTS LIST FOR FIGURE D

KEY NO.	PART NUMBER	DESCRIPTION	QUAN.
1	981356-001	Data Plate .....	1
2	976308-001	Base Assembly .....	1
3	976386-001	* Screw (5/16-18 x 3/4 in. Hex Washer Hd.) .....	2
4	976296-001	Elevation Nut .....	1
5	976294-001	Column Assembly .....	1
6	976293-001	Retaining Ring .....	1
7	976292-001	Arm Latch .....	1
8	** STD503705	* Setscrew (3/8-16 x 1/2 in. Soc. Hd.) .....	3
9	** STD541031	* Hex Nut (5/16-18) .....	17
10	977492-001	* Locking Cap Screw (1/4-20 x 5/8 in.) .....	2
11	976289-002	Support (LH) .....	1
12	976295-001	Column Tube GIB .....	2
13	976833-001	Elevating Shaft Assembly .....	1
14	976290-002	Support (RH) .....	1
15	615570-022	* Bolt (5/16-18 x 2 in. Hex Hd.) .....	12
16	615570-021	* Bolt (5/16-18 x 2 in. Hex Hd.) .....	2
17	** STD523712	* Bolt (3/8-16 x 1-1/4 in. Hex Hd.) .....	4
18	617264-001	Washer .....	8
19	615570-020	* Bolt (5/16-18 x 3/4 in. Hex Hd.) .....	2
20	** STD551137	* Lock Washer (3/8) .....	4
21	615570-007	* Bolt (5/16-18 x 1-1/8 in. Hex Hd.) .....	1
22	** STD541037	* Hex Nut (3/8-16) .....	4
23	976301-001	Elevating Crank Shaft .....	1
24	** STD581062	Retaining Ring .....	1
25	976302-001	Bushing .....	1
26	623111-006	Retaining Ring .....	1
27	622141-002	Washer .....	2
28	976300-001	Elevating Shaft Bearing .....	1
29	706239-932	Washer .....	2
30	976299-001	Bevel Pinion Gear .....	1
31	623111-001	Retaining Ring .....	1
32	** STD571450	* Lock Nut (1/2-13) .....	1
33	976298-001	Bevel Gear .....	1
34	976297-001	Bearing .....	2

\* Standard Hardware Item — May Be Purchased Locally

\*\* Available From Div. 98 — Source 980.00

# CRAFTSMAN RADIAL ARM SAW – MODEL NO. 315.220381

The model number will be found on a plate attached to the base. Always mention the model number in all correspondence regarding your **RADIAL ARM SAW** or when ordering repair parts.

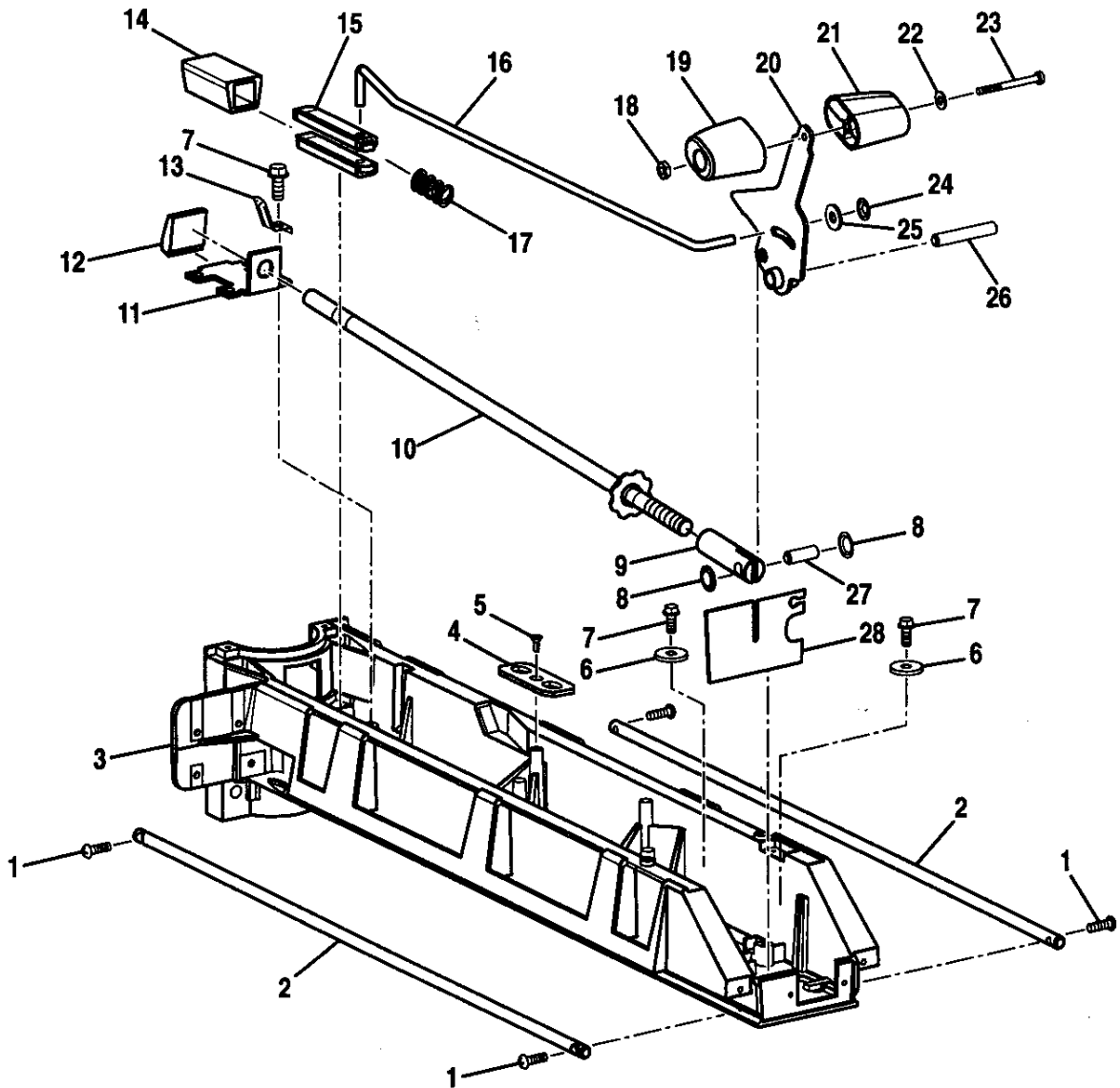

FIGURE E

## CRAFTSMAN RADIAL ARM SAW – MODEL NO. 315.220381

The model number will be found on a plate attached to the base. Always mention the model number in all correspondence regarding your **RADIAL ARM SAW** or when ordering repair parts.

### PARTS LIST FOR FIGURE E

KEY NO.	PART NUMBER	DESCRIPTION	QUAN.
1	622210-043	* Screw (10-32 x 5/8 in. Rd. Hd.) .....	4
2	976323-001	Track .....	2
3	976326-002	Arm .....	1
4	980613-001	Support Bracket .....	1
5	611114-002	* Screw (10-32 x 1/2 in. Flat Head T. C.) .....	1
6	706382-834	Washer .....	2
7	980455-001	* Screw (1/4-20 x 5/8 in. Self Tapping Hex Washer Hd.) .....	6
8	641180-005	Push Nut (3/8 in.) .....	2
9	976321-001	Clevis Pin .....	1
10	976804-001	Arm Lock Rod Assembly .....	1
11	976314-001	Guide .....	1
12	976312-001	Arm Lock Pawl .....	1
13	976313-001	Tension Spring .....	1
14	976310-001	Pin Housing .....	1
15	976311-001	Arm Index Pin .....	2
16	976315-001	Index Rod .....	1
17	976316-001	Arm Lock Spring .....	1
18	** STD541110	* Hex Nut (10-32) .....	1
19	976329-001	Arm Knob Lever (Left Hand) .....	1
20	976827-001	Arm Lock Lever Assembly .....	1
21	976330-001	Arm Knob Lever (Right Hand) .....	1
22	931055-006	Washer .....	1
23	606066-011	* Screw (10-32 x 2-1/4 in. Pan Hd.) .....	1
24	641180-006	Push Nut (1/4 in.) .....	1
25	931744-059	Washer .....	1
26	976319-001	Lever Pin .....	1
27	976320-001	Pin .....	1
28	976322-001	Arm Insulation .....	1

\* Standard Hardware Item — May Be Purchased Locally

\*\* Available From Div. 98 — Source 980.00



## CRAFTSMAN RADIAL ARM SAW – MODEL NO. 315.220381

The model number will be found on a plate attached to the base. Always mention the model number in all correspondence regarding your **RADIAL ARM SAW** or when ordering repair parts.

### PARTS LIST FOR FIGURE F

KEY NO.	PART NUMBER	DESCRIPTION	QUAN.
1	980548-001	Carriage Lock Label .....	1
2	976358-001	Carriage Lock Knob .....	1
3	** STD511105	* Screw (10-32 x 1/2 in. Pan Hd.) .....	4
4	976287-001	Carriage Cover (LH) .....	1
5	976348-001	Rip Scale Indicator .....	2
6	** STD510606	* Screw (6-32 x 5/8 in. Pan Hd.) .....	4
7	976352-001	Speed Nut .....	2
8	976409-001	Swivel Latch Spring .....	1
9	976286-002	Carriage .....	1
10	976831-001	Thrust Washer .....	8
11	976285-001	Carriage Bearing .....	4
12	976337-001	Washer .....	4
13	976349-001	Eccentric Screw .....	2
14	976350-001	Rip Lock Shoe .....	1
15	976353-001	Bumper .....	2
16	976278-001	Yoke Clamp Stud Assembly .....	1
17	999982-001	Washer .....	2
18	** STD541462	* Lock Nut (5/8-11) .....	1
19	976385-001	Sleeve Bearing .....	2
20	620074-001	* Bolt (5/16-18 x 1-1/2 in. Hex Hd.) .....	2
21	615570-020	* Bolt (5/16-18 x 3/4 in. Hex Hd.) .....	2
22	** STD551231	* Lock Washer (5/16) .....	2
23	624088-002	Washer .....	2
24	976345-001	Spring Bracket .....	1
25	976771-001	Index Spring .....	1
26	976346-001	Yoke Pivot Latch .....	1
27	976288-001	Carriage Cover (RH) .....	1
28	976347-002	Index Pin Housing .....	1
29	624282-002	* Square Nut (5/16-18) .....	2
30	** STD541031	* Hex Nut (5/16-18) .....	4
31	980538-001	Yoke Lock Label .....	1
32	976472-001	Yoke Lock Handle (Includes Key No. 31) .....	1
33	980524-001	Switch Label .....	1
34	980526-001	Warning Label .....	1

\* Standard Hardware Item — May Be Purchased Locally  
 \*\* Available From Div. 98 — Source 980.00

# CRAFTSMAN RADIAL ARM SAW – MODEL NO. 315.220381

The model number will be found on a plate attached to the base. Always mention the model number in all correspondence regarding your **RADIAL ARM SAW** or when ordering repair parts.

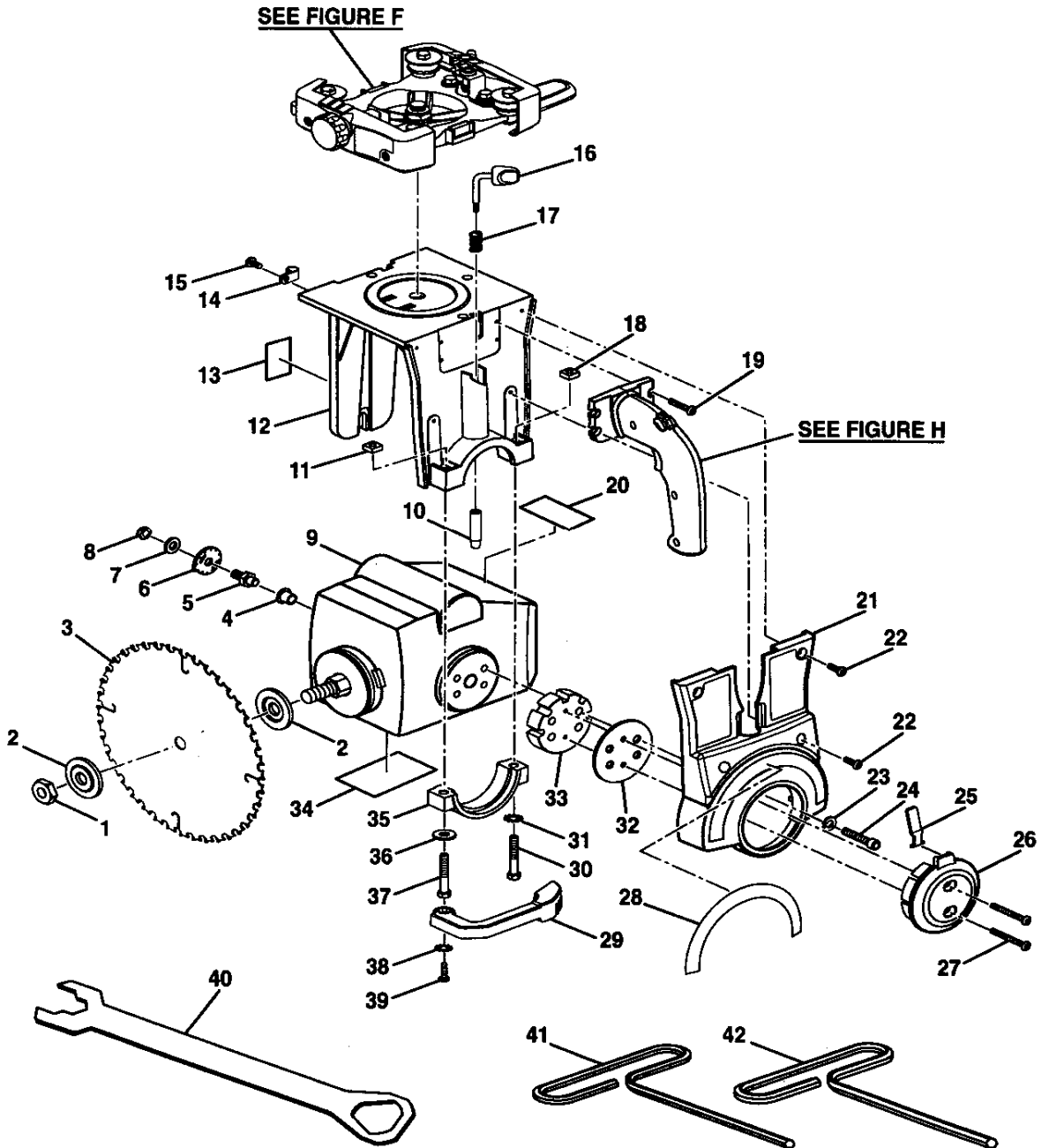

FIGURE G

## CRAFTSMAN RADIAL ARM SAW – MODEL NO. 315.220381

The model number will be found on a plate attached to the base. Always mention the model number in all correspondence regarding your **RADIAL ARM SAW** or when ordering repair parts.

### PARTS LIST FOR FIGURE G

KEY NO.	PART NUMBER	DESCRIPTION	QUAN.
1	976773-001	Blade Nut .....	1
2	976284-001	Blade Washer .....	2
3	***	Saw Blade .....	1
4	976271-001	Rubber Bushing .....	1
5	976272-001	Motor Stud .....	1
6	976273-001	Motor Cam .....	1
7	703776-098	Washer .....	1
8	** STD541437	* Lock Nut (3/8-16) .....	1
9	976249-001	Motor .....	1
10	976281-001	Index Pin .....	1
11	977225-001	Nut (5/16) .....	1
12	976268-002	Yoke .....	1
13	980556-001	Outfeed Warning Label .....	1
14	989001-002	Cable Clamp (5/16 in.) .....	2
15	** STD511103	* Screw (10-32 x 3/8 in. Pan Hd.) .....	2
16	976279-001	Bevel Index Knob .....	1
17	976772-001	Swivel Latch Spring .....	1
18	624282-002	Nut .....	1
19	** STD511107	* Screw (10-32 x 3/4 in. Pan Hd.) .....	4
20	980554-001	Infeed Warning Label .....	1
21	976275-001	Yoke Cover .....	1
22	** STD511105	* Screw (10-32 x 1/2 in. Pan Hd.) .....	4
23	** STD551131	* Lock Washer (5/16) .....	4
24	969220-006	Screw (5/16-18 x 2 in. Soc. Cap) .....	4
25	977250-001	Bevel Indicator .....	1
26	976338-001	Bevel Index Cap .....	1
27	606066-012	* Screw (10-32 x 1-5/8 in. Pan Hd.) .....	2
28	980522-001	Bevel Scale Label .....	1
29	976274-002	Bevel Lock Lever .....	1
30	615570-022	* Bolt (5/16-18 x 2 in. Hex Hd.) .....	1
31	** STD551231	Lock Washer (5/16) .....	1
32	976832-001	Retainer Plate .....	1
33	976265-001	Index Ring .....	1
34	980552-001	Edging Warning Label .....	1
35	976267-002	Yoke Cap .....	1
36	624088-002	Washer .....	1
37	976391-001	Bolt (5/16-18 Hex Hd.) .....	1
38	621032-002	Star Washer .....	1
39	998991-002	Screw (10-32 x 5/8 in. Hex Soc. Button Hd.) .....	1
40	977245-001	Blade Wrench .....	2
41	976481-001	* 3/16 in. Hex Key .....	1
42	976481-002	* 1/4 in. Hex Key .....	1

\* Standard Hardware Item — May Be Purchased Locally

\*\* Available From Div. 98 — Source 980.00

\*\*\* Complete Assortment Available At Your Nearest Sears Retail Store

**CRAFTSMAN RADIAL ARM SAW – MODEL NO. 315.220381**

The model number will be found on a plate attached to the base. Always mention the model number in all correspondence regarding your **RADIAL ARM SAW** or when ordering repair parts.

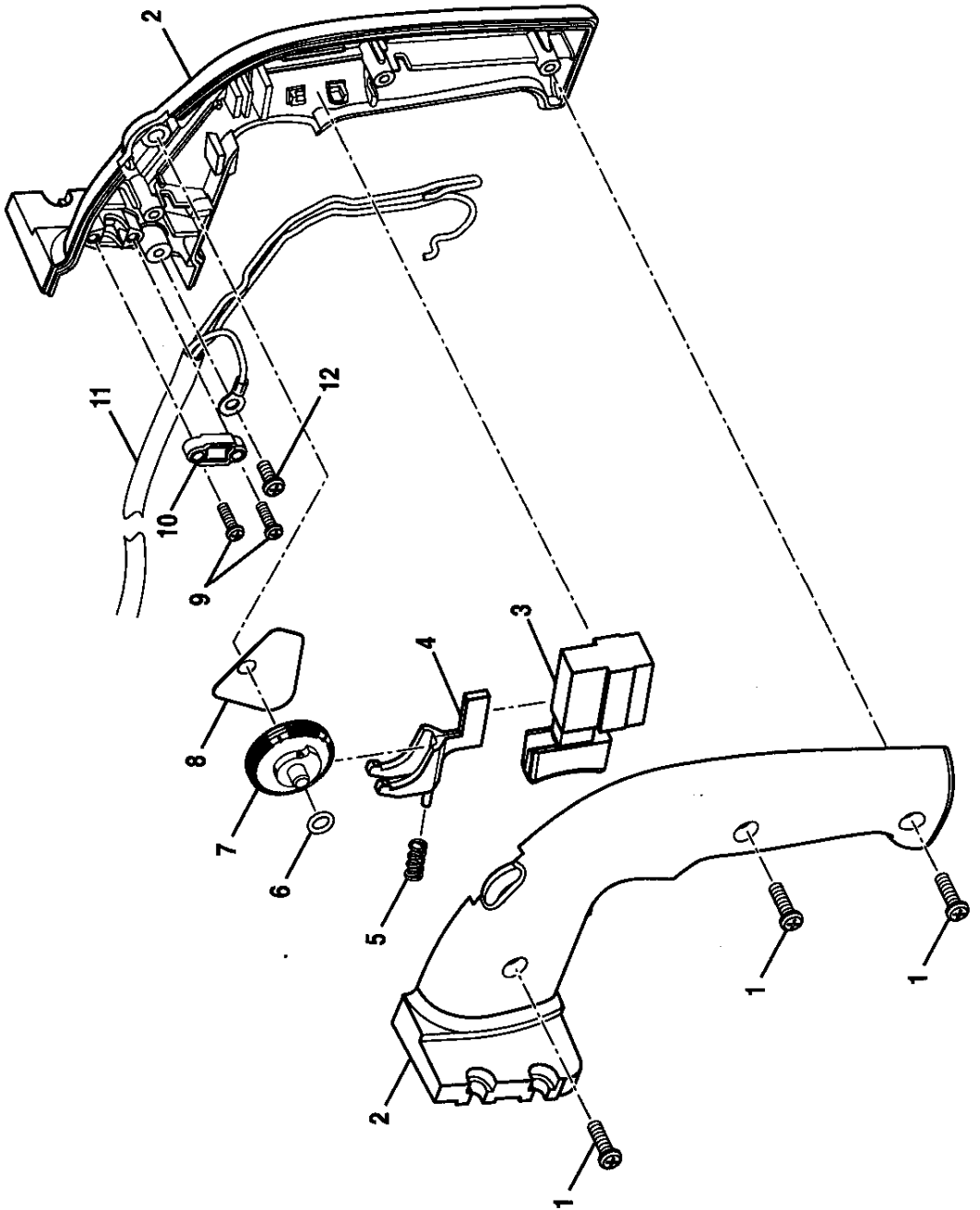

**FIGURE H**

**CRAFTSMAN RADIAL ARM SAW — MODEL NO. 315.220381**

The model number will be found on a plate attached to the base. Always mention the model number in all correspondence regarding your **RADIAL ARM SAW** or when ordering repair parts.

**PARTS LIST FOR FIGURE H**

KEY NO.	PART NUMBER	DESCRIPTION	QUAN.
1	610122-006	* Screw (8-32 x 5/8 in. Pan Hd.)	3
2	976449-001	Handle Assembly	1
3	971665-001	Switch Trigger	1
4	977207-001	Cam Lever	1
5	998196-001	Spring	1
6	607617-003	O-Ring	1
7	977203-001	Knob	1
8	976336-001	Wiring Insulator	1
9	** STD600605	* Screw (6-32 x 1/2 in. Pan Hd. T.C.)	2
10	967917-001	Cord Clamp	1
11	976785-001	Cord Harness	1
12	** STD510803	* Screw (8-32 x 3/8 in. Pan Hd.)	1

\* Standard Hardware Item — May Be Purchased Locally  
 \*\* Available From Div. 98 — Source 980.00

**CRAFTSMAN RADIAL ARM SAW – MODEL NO. 315.220381**

The model number will be found on a plate attached to the base. Always mention the model number in all correspondence regarding your **RADIAL ARM SAW** or when ordering repair parts.

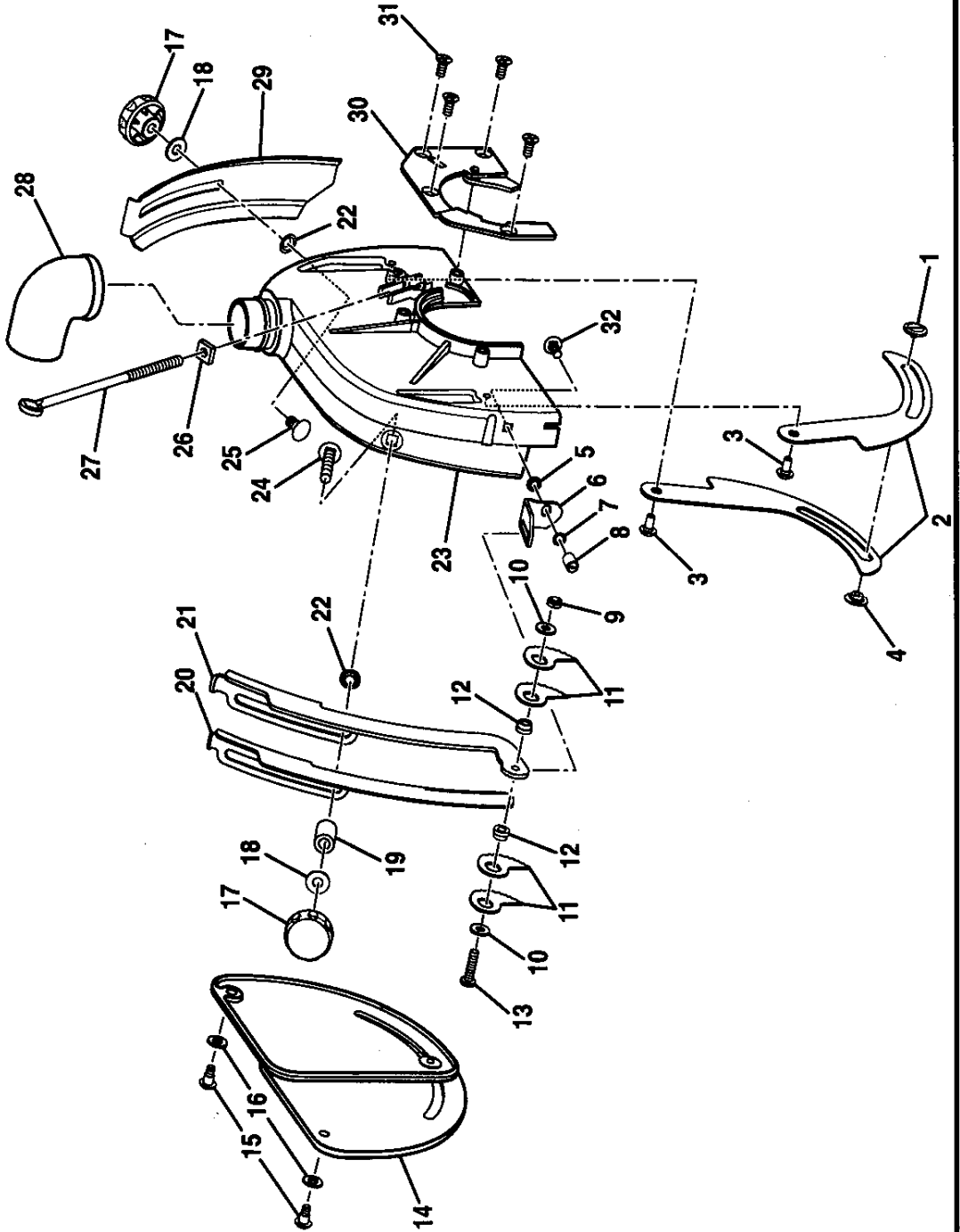

**FIGURE 1**

The model number will be found on a plate attached to the base. Always mention the model number in all correspondence regarding your **RADIAL ARM SAW** or when ordering repair parts.

**PARTS LIST FOR FIGURE I**

KEY NO.	PART NUMBER	DESCRIPTION	QUAN.	KEY NO.	PART NUMBER	DESCRIPTION	QUAN.
1	976366-001	Guard Screw (10-24 Slotted)	1	17	977246-001	Guard Knob	2
2	977237-001	Inner Lower Guard	2	18	706382-041	Washer	2
3	976370-002	Shoulder Screw (1/4-20 Button Hd.)	2	19	977254-001	Spacer	1
4	979528-001	Guard Nut (10-24)	1	20	977240-001	Riving Knife	1
5	641180-003	* Push Nut (1/4 in.)	1	21	977239-001	Anti-Kickback Bracket	1
6	977244-001	Knife Support	1	22	641180-004	* Push Nut (5/16 in.)	2
7	621032-009	Star Washer	1	23	976879-002	Upper Guard	1
8	977478-001	Slotted Nut	1	24	977480-003	* Bolt (5/16-18 x 1-3/4 in. Rd. Hd.)	1
9	** STD541425	* Lock Nut (1/4-20)	1	25	** STD533106	* Bolt (5/16-18 x 5/8 in. Rd. Hd.)	1
10	931744-059	Washer	2	26	977225-001	Square Nut	1
11	977243-001	Anti-Kickback Pawl	4	27	977224-001	Guard Clamp Screw	1
12	977253-001	Bushing	2	28	977223-001	Dust Guide	1
13	** STD512510	* Screw (1/4-20 x 1 in. Pan Hd.)	1	29	977238-001	Hold Down Guard	1
14	980498-001	Outer Lower Guard Assembly	1	30	977230-001	Upper Guard Retainer Assembly	1
15	976370-001	Shoulder Screw (1/4-20 Button Hd.)	2	31	622210-041	* Screw (1/4-20 x 9/16 in. Flat Hd. T. F.)	4
16	703493-804	Washer	2	32	977480-001	* Bolt (1/4-20 x 5/8 in. Rd. Hd.)	1

\* Standard Hardware Item — May Be Purchased Locally  
 \*\* Available From Div. 98 — Source 980.00

**CRAFTSMAN RADIAL ARM SAW – MODEL NO. 315.220381**

The model number will be found on a plate attached to the base. Always mention the model number in all correspondence regarding your **RADIAL ARM SAW** or when ordering repair parts.

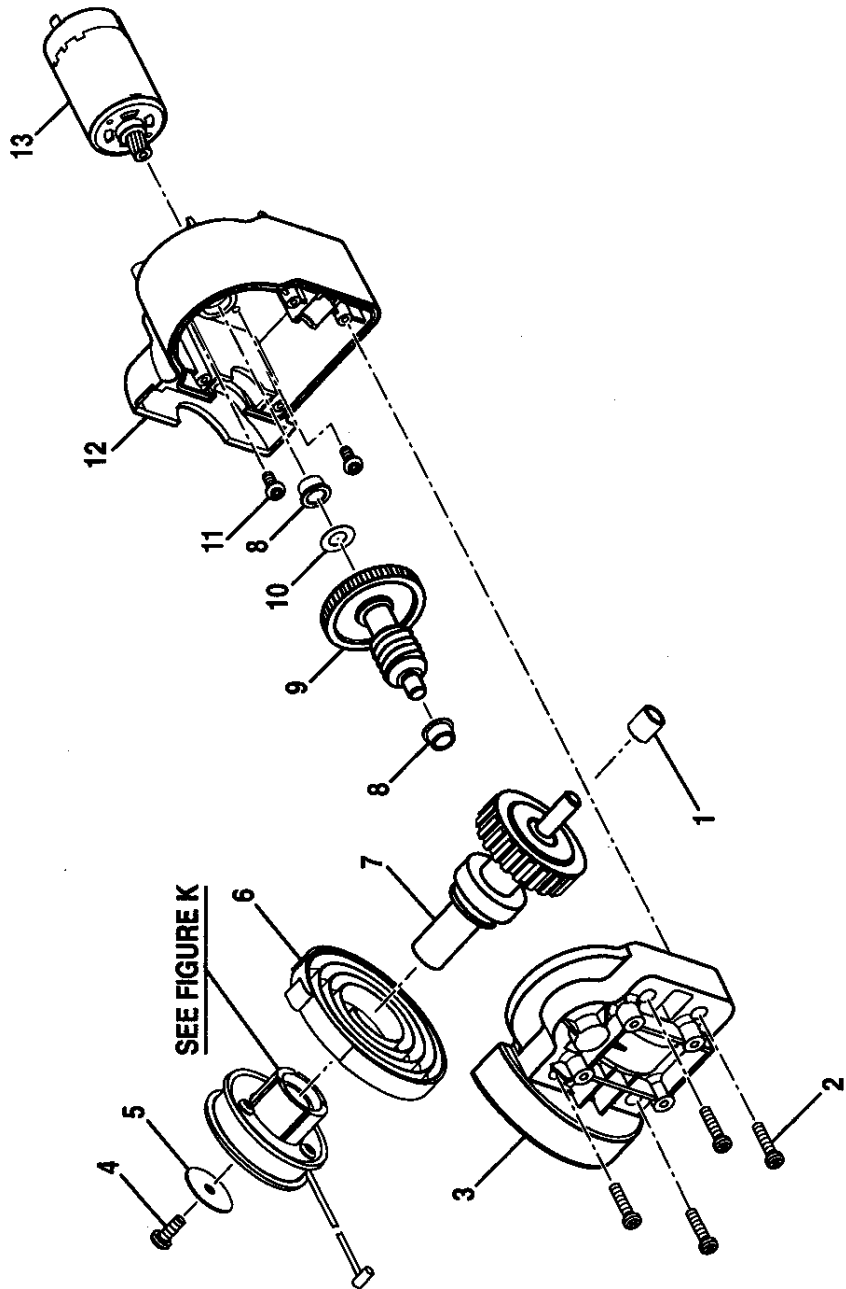

**SEE FIGURE K**

**FIGURE J**

The model number will be found on a plate attached to the base. Always mention the model number in all correspondence regarding your **RADIAL ARM SAW** or when ordering repair parts.

**PARTS LIST FOR FIGURE J**

KEY NO.	PART NUMBER	DESCRIPTION	QUAN.
1	607818-002	Sleeve Bearing .....	1
2	990908-009	* Screw (6-19 x 5/8 in. Pan Hd.) .....	4
3	976450-001	Gear Case Cover .....	1
4	** STD511005	* Screw (10-24 x 1/2 in. Pan Hd.) .....	1
5	662029-001	Washer .....	1
6	977215-001	Spring .....	1
7	976416-001	Pulley Shaft Assembly .....	1
8	644186-002	Sleeve Bearing (Flange) .....	2
9	976414-001	Worm Gear Assembly .....	1
10	706239-830	Washer .....	1
11	090403-080	Screw (M3 x 8 Pan Hd.) .....	2
12	976411-001	Gear Case .....	1
13	976412-001	Motor Assembly .....	1

\* Standard Hardware Item — May Be Purchased Locally  
 \*\* Available From Div. 98 — Source 980.00

**CRAFTSMAN RADIAL ARM SAW -- MODEL NO. 315.220381**

The model number will be found on a plate attached to the base. Always mention the model number in all correspondence regarding your **RADIAL ARM SAW** or when ordering repair parts.

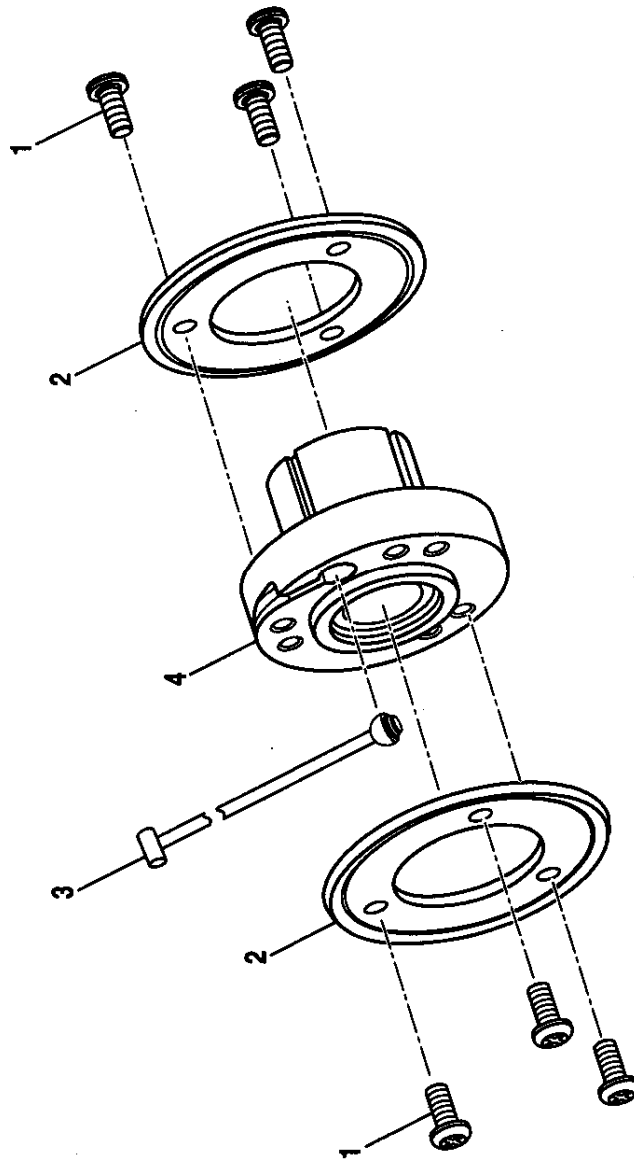

**FIGURE K**

The model number will be found on a plate attached to the base. Always mention the model number in all correspondence regarding your RADIAL ARM SAW or when ordering repair parts.

**PARTS LIST FOR FIGURE K**

KEY NO.	PART NUMBER	DESCRIPTION	QUAN.
1	** STD510803	* Screw (8-32 x 3/8 in. Pan Hd.)	6
2	662028-001	Pulley Flange	2
3	976420-001	Cable Assembly	1
4	976421-001	Clutch Assembly	1

\* Standard Hardware Item — May Be Purchased Locally  
 \*\* Available From Div. 98 — Source 980.00

**In U.S.A. or Canada  
for in-home major brand repair service:**

Call 24 hours a day, 7 days a week

**1-800-4-MY-HOME<sup>SM</sup>** (1-800-469-4663)

**Para pedir servicio de reparación a domicilio – 1-800-676-5811**

Au Canada pour tout le service ou les pièces – 1-800-469 4663

**For the repair or replacement parts you need:**

Call 6 a.m. – 11 p.m. CST, 7 days a week

**Parts Direct<sup>SM</sup>**

**1-800-366-PART** (1-800-366-7278)

**Para ordenar piezas con entrega a domicilio – 1-800-659-7084**

**For the location of a Sears Service Center in your area:**

Call 24 hours a day, 7 days a week

**1-800-488-1222**

**To purchase or inquire about a Sears Maintenance Agreement:**

Call 7 a.m. – 5 p.m. CST, Monday – Saturday

**1-800-827-6655**

