

Save This Manual
For Future Reference

SEARS

**owner's
manual**

CATALOG NO.

9-29012

9-29013

FITS THE FOLLOWING
MODEL NUMBERS:

113.197110, 113.197111,

113.197150, 113.197151,

113.197210, 113.197211,

113.197250, 113.197251,

113.197410, 113.197411,

113.197510, 113.197511,

113.197610, 113.197611,

113.197180, 113.197181

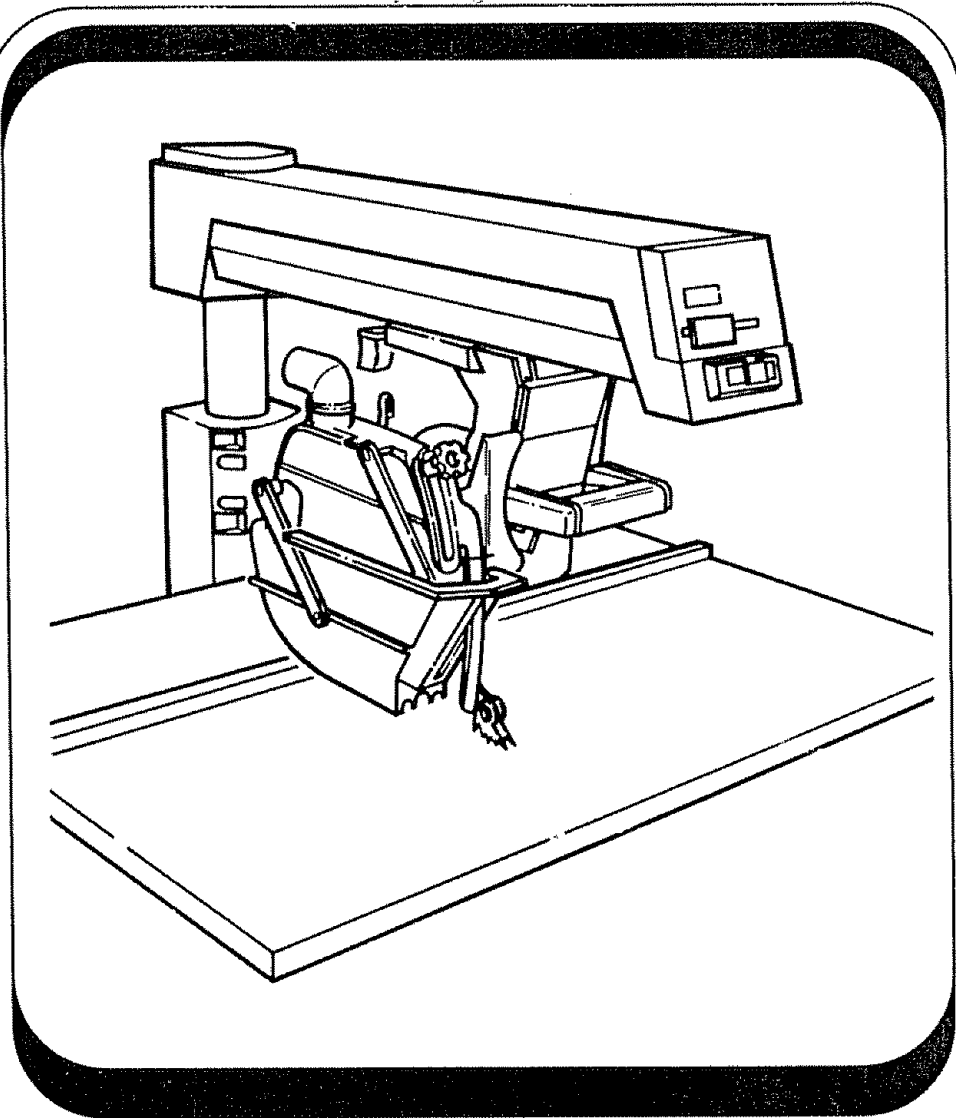

SEARS / CRAFTSMAN®

10-INCH RADIAL SAW GUARD KIT

**FOR YOUR
SAFETY:**

**READ ALL
INSTRUCTIONS
CAREFULLY**

- assembly
- operating
- repair parts

Sold by SEARS, ROEBUCK AND CO., Chicago, IL 60684 U.S.A.

Part No. SP5623

Printed in U.S.A.

Table of Contents

Section Title.....	Page
Safety.....	3
Assembly.....	8
Repair Parts	17

FULL ONE YEAR WARRANTY ON CRAFTSMAN RADIAL ARM SAW GUARD KIT

If within one year from the date of purchase, this Craftsman Radial Saw Guard Kit fails due to a defect in material or workmanship, Sears will repair it, free of charge.

WARRANTY SERVICE IS AVAILABLE BY SIMPLY CONTACTING THE NEAREST SEARS SERVICE CENTER/DEPARTMENT THROUGHOUT THE UNITED STATES.

This warranty applies only while this product is used in the United States.

This warranty gives you specific legal rights and you may also have other rights which vary from state to state.

**SEARS, ROEBUCK AND CO. D/817 WA
Hoffman Estates, IL 60195**

This manual has safety information and instructions to help users eliminate or reduce the risk of accidents and injuries, including:

1. Severe cuts, and loss of fingers or other body parts due to contact with the blade.
2. Eye impact injuries, and blindness, from being hit by a thrown workpiece, workpiece chips or pieces of blade.
3. Bodily impact injuries, broken bones, and internal organ damage from being hit by a thrown workpiece
4. Shock or electrocution
5. Burns.

Safety Symbol and Signal Words

An exclamation mark inside a triangle is the safety alert symbol.

It is used to draw attention to safety information in the manual and on the saw. It is followed by a signal word, DANGER, WARNING, or CAUTION, which tells the level of risk:

▲ DANGER: means if the safety information is not followed someone **will** be seriously injured or killed.

▲ WARNING: means if the safety information is not followed someone **could** be seriously injured or killed.

▲ CAUTION: means if the safety information is not followed someone **might** be injured.

Read and follow all safety information and instructions.

Major Hazards

Three major hazards are associated with using the radial arm saw for ripping. They are outfeed zone hazard, kickback, and wrong way feed.

This section only briefly explains these hazards. Read the ripping and crosscutting safety sections of your saw manual for more detailed explanations of these and other hazards.

Outfeed Zone Hazard

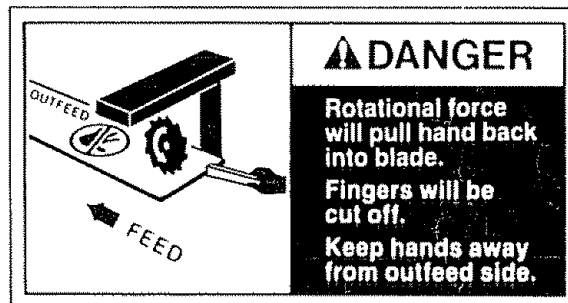

If you reach around the blade to the outfeed side when ripping, and try to hold down or pull the workpiece through to complete a cut, the rotational force of the blade will pull your hand back into the blade.

Fingers will be cut off.

Safety

Kickback Hazard

Kickback is the uncontrolled propelling of the workpiece back toward the user during ripping.

The cause of kickback is the binding or pinching of the blade in the workpiece. Several conditions can cause the blade to bind or pinch.

When a workpiece kicks back, it could hit hard enough to cause internal organ injury, broken bones, or death.



Wrong Way Feed Hazard

Wrong way feed is ripping by feeding the workpiece into the outfeed side of the blade.

The rotational force of the blade can grab and pull the workpiece.

Before you can let go or pull back, the force could pull your hand along with the workpiece into the blade. Fingers or hand could be cut off.

The propelled workpiece could hit a bystander, causing severe impact injury or death.



Safety Instructions

Read and follow all safety instructions.

Personal Safety Instructions

1. Wear safety goggles labeled “ANSI Z87.1” on the package. It means the goggles meet impact standards set by the American National Standards Institute. Regular eye-glasses are not safety goggles.
2. Wear close fitting clothes, short sleeved shirts, and non-slip shoes. Tie up long hair. Do not wear gloves, ties, jewelry, loose clothing, or long sleeves. These can get caught in the spinning blade and pull body parts into the blade.
3. Wear dust mask to keep from inhaling fine particles.
4. Wear ear protectors, plugs or muffs if you use saw daily.
5. Keep good footing and balance; do not over-reach.

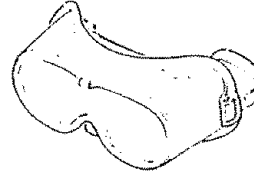

Safety Goggles



Dust Mask

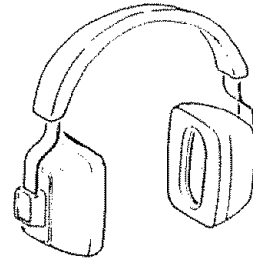

Ear Protectors

Work Area Safety Instructions

1. Keep children, pets, and visitors out of work area; they could be hit by a thrown workpiece, workpiece chips or pieces of blade.
2. Turn saw off, remove yellow key, and unplug before leaving work area. Do not leave until blade has stopped spinning.
3. Make work area child-proof: remove yellow key to prevent accidental start-up; store key out of sight and reach; lock work area.
4. Keep floors clean and free of sawdust, wax and other slippery materials.
5. Keep work area well lighted and uncluttered.
6. Use saw only in dry area. Do not use in wet or damp areas.

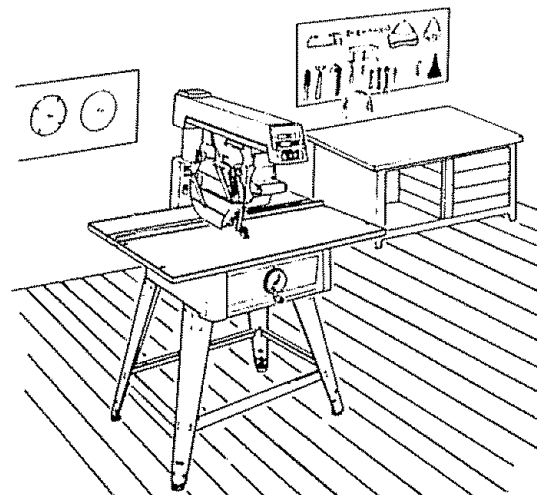

Safety

Saw Safety Instructions

1. Use guard, pawls and riving knife according to instructions. Keep them in working order.
2. Routinely check saw for broken or damaged parts. Repair or replace damaged parts before using saw. Check new or repaired parts for alignment, binding, and correct installation.
3. Unplug saw before doing maintenance, making adjustments, correcting alignment, or changing blades.
4. Do not force saw. Use saw, blades and accessories only as intended.
5. Have yellow key out and saw switched off before plugging in power cord.
6. Before turning on saw, clear table of all objects except workpiece to be cut and necessary fixtures, clamps, or feather-boards.
7. If blade jams, turn saw off immediately, remove yellow key, the free blade. Do not try to free blade with saw on.
8. Turn saw off if it vibrates too much or makes an odd sound. Correct any problem before restarting saw.
9. Do not layout, assemble, or setup work with saw on, or while blade is spinning.
10. Keep saw table clean.
11. Store items away from saw. Do not climb on saw or stand on saw table to reach items because saw can tip over.

Workpiece Safety Instructions

1. Cut only wood, woodlike or plastic materials. Do not cut metal.

2. Cut only one workpiece at a time. Stacking or placing workpieces edge to edge can cause user to lose control of workpiece.

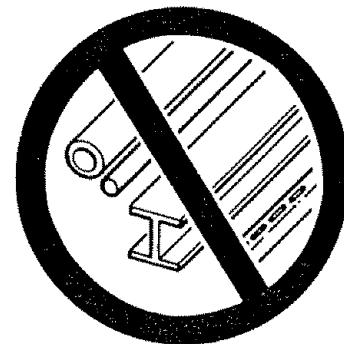
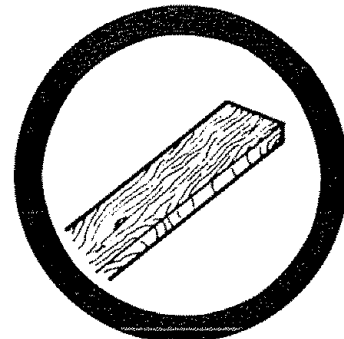

3. Rip only workpieces longer than the diameter of the blade. Do not rip workpieces that are shorter than the diameter of the blade being used.

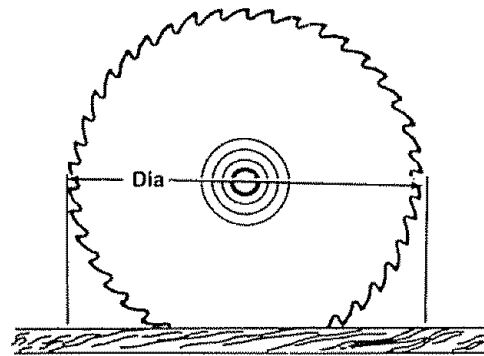

4. Workpieces that extend beyond the saw table can shift, twist, rise up from the table, or fall as they are cut or afterwards. Support workpiece with table extensions the same height as the saw table.

5. To prevent tipping, support outer ends of extensions with sturdy legs or an outrigger.

6. Do not use another person to help support workpieces or to aid by pushing or pulling on workpieces, because these actions can cause kickback. Use table extensions.

7. Use clamps or vice to hold workpiece. It's safer than using your hands.

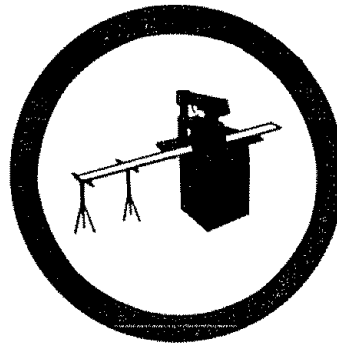

Blade Safety Instructions

1. Use only blades marked for at least 3450 rpm.
2. Use only 10" or smaller diameter blades.
3. Use blades for their recommended cutting procedures.
4. Keep blade sharp and clean.

5. Do not overtighten blade nut because blade collar could warp.

6. Do not turn saw on and off in rapid sequence because blade can loosen.

7. Blade should stop within 15 seconds after saw is switched off. If blade takes longer, the saw needs repair. Contact Sears Service Center.

Assembly

Identify Parts

The following parts are included:

Note: Before beginning assembly, check that all parts are included. If you are missing any part, do not assemble guard. Contact your Sears Service Center to get the missing part. Sometimes small parts can get lost in packaging material. Do not throw away any packaging until guard is put together. Check packaging for missing parts before contacting Sears. A complete parts list (Repair Parts) is at the end of the manual. Use the list to identify the number of the missing part.

List of loose parts with catalog #9-29012

- A. Guard Assembly 1
- B. Rear Table 40" 1
- C. Spacer Table 40" 1
- D. Front Table 40" 1
- E. Table Support 2
- F. Handle Assembly 1
- G. Bag Of Loose Parts 1
Containing:
- H. Adapter Motor Key 1
- I. Screw Pan Hd Ty T
6-32 x 1/2 1
- J. Screw Flat Hd Plastite
#10 x 3/4 2
- K. Tee Nut 1
- L. Bag Of Loose Parts 1
Containing:
- M. Guard Accessory 1
- N. Screw Plastite #8 x 1/2 1
- O. Washer 3/16 x 1 x 1/16 1
- P. Owners Manual 1

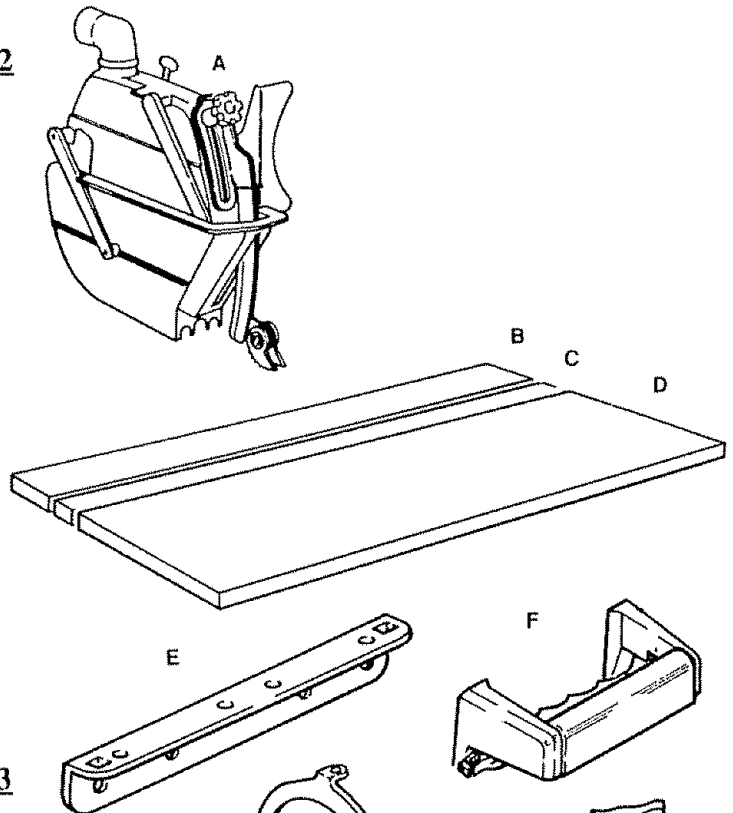

List of loose parts with catalog #9-29013

- A. Guard Assembly 1
- B. Rear Table 44" 1
- C. Spacer Table 44" 1
- D. Front Table 44" 1
- E. Handle Assembly 1
- G. Bag Of Loose Parts 1
Containing:
- H. Adapter Motor Key 1
- I. Screw Pan Hd Ty T
6-32 x 1/2 1
- J. Screw Flat Hd Plastite
#10 x 3/4 2
- K. Tee Nut 1
- L. Bag Of Loose Parts 1
Containing:
- M. Guard Accessory 1
- N. Screw Plastite #8 x 1/2 1
- O. Washer 3/16 x 1 x 1/16 1
- P. Owners Manual 1

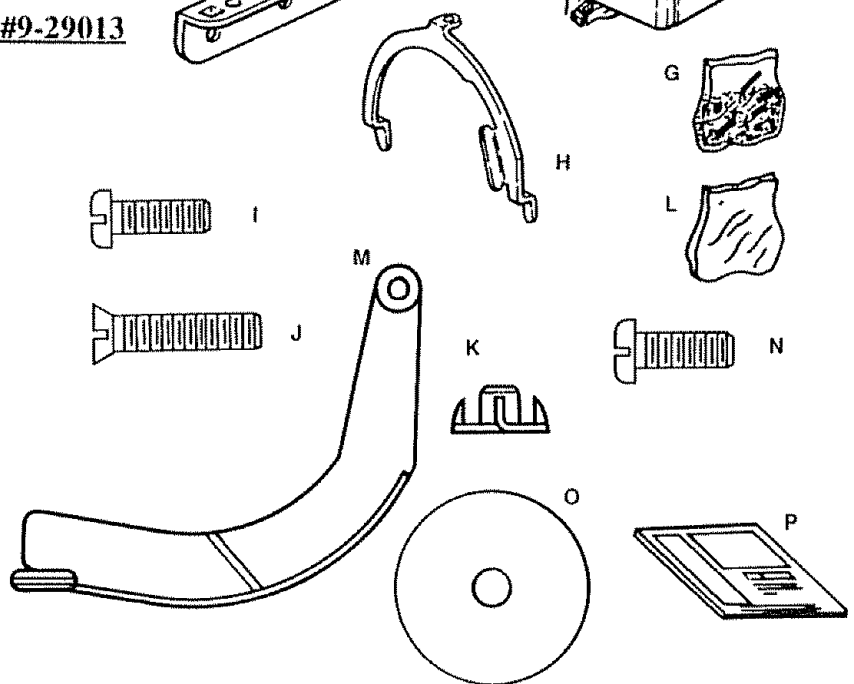

Assembly

Guard Installation Steps

1. Remove existing table boards. Keep all screws, nuts and washers, including the levelling screws in the center of the front table. Discard the old table boards but keep the fence.

2. 40" TABLE ONLY (if you have the 44" table, skip to next step):

- Remove the table support channels, keeping the screws, nuts and washers. Discard the old channels.
- Install the new support channels.
- Referring to your saw owners manual, level the channels and tighten them in place.
- Install the tee nut into the front table board.
- Referring to your saw owners manual, install and level the table boards.

3. 44" TABLE ONLY (if you have the 40" table, skip to next step):

- Position the front table and insert the front two screws. The rear screw holes in the table do not line up on any holes in the saw base.
- Using the rear screw holes as a drill guide, drill a 5/16" hole in the saw base for each of the two rear screws.
- Remove the front table.
- The U-Clips that were used as nuts for the rear screws must be moved to the new screw location. Remove them from the saw and reinstall them on the holes you just drilled.
- Install the tee nut into the front table board.
- Referring to your saw owners manual, install and level the table boards.

4. The saw's crosscut travel may no longer be square. Referring to your saw owners manual, square the crosscut travel.

5. Remove the existing guard and blade. Rotate the saw to the outtrip position.

6. Elevate and rotate the saw to the 45 degree bevel position. Remove and discard one of the handle retaining screws.

Note: This retro fit guard kit requires additional clearance behind fence. New table boards are being supplied for this reason.

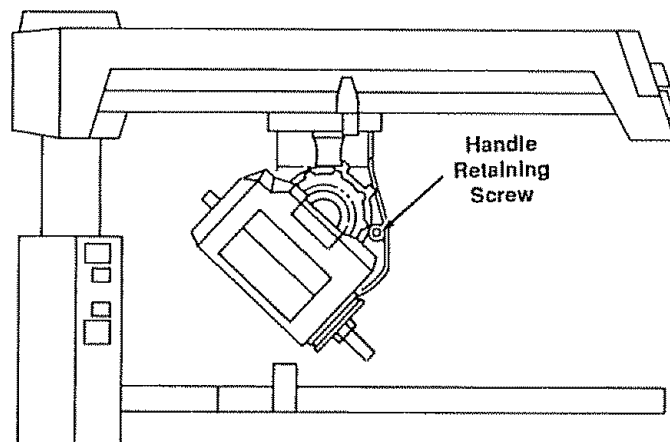

Assembly

7. Rotate the saw to the negative 45 degree bevel position. Remove and discard the other handle retaining screw. Discard the old handle.

8. Using the two #10 x 3/4 flat head screws provided, attach the new handle in the same way as the old one was removed.

9. Return the saw to the blade vertical, cross-cut position.

10. Remove the top motor cover screw and lock washer. Keep the washer. Discard the old screw.

11. Install the adapter. The two ends of the adapter fit into the center cooling slots of the motor, then the adapter is rotated up into place.

12. Install the replacement screw (#6 x 1/2") with the old lock washer into the top motor cover hole. This locks the adapter in place.

13. Reinstall the blade.

Note: *The rip scale for the front fence position is no longer correct. Subtract 1-1/8" from the scale reading to obtain the correct reading.*

Install Guard

The guard is a very important safety feature. It covers a large part of the blade and helps protect against severe cuts. Always use the guard.

1. Lock motor at 0° bevel (blade vertical).
2. Use one hand to lift clear plastic guard; use other hand to grasp rear of guard (below dust elbow). Position guard so riving knife faces front of saw.
3. Tilt front of guard down about 45°; place over blade; rotate guard to level position.

Note: *Make sure notch in guard fits onto tab on motor adapter. This will prevent movement of guard about motor. Squeeze handle trigger to make sure it raises clear plastic guard. If it does not, remove and re-install guard, making sure that trigger mechanism engages pull link on guard.*

4. Tighten guard clamp screw.

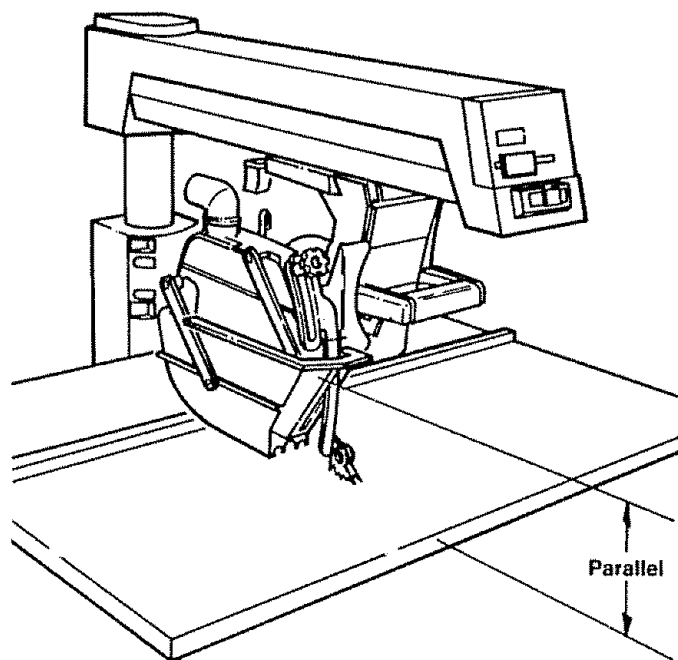
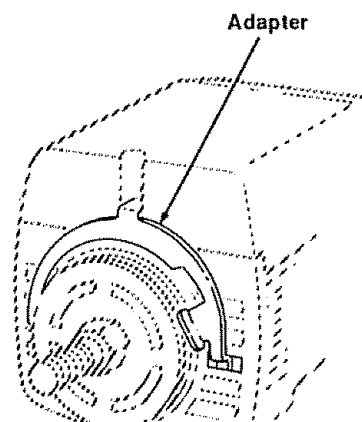
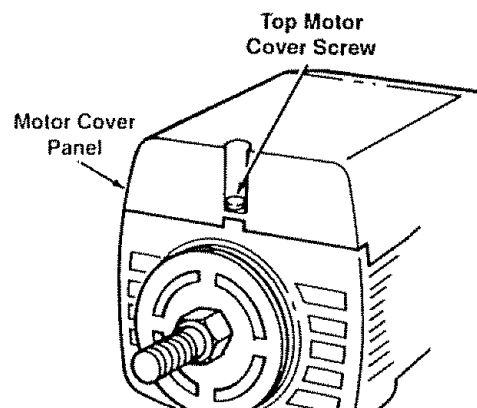

Alignment

Align Riving Knife to Blade

The goal of this adjustment is to position the riving knife directly in line with the blade. Riving knife alignment is an important safety factor. The riving knife rides in the kerf of the cut workpiece during ripping to keep the two sides of the workpiece from pinching on the blade. Blade pinching is a cause of kick-back.

1. Lock yoke in in-rip position (blade towards column, motor towards front of arm).
2. Lower arm until blade just clears table.
3. Unlock rip lock while holding up lower plastic guard, move yoke back until blade touches fence. Lock rip lock.
4. Loosen pawls/riving knife knob. Lower riving knife to the table and tighten knob. The riving knife should rest flat against fence.
5. If adjustment is needed:
 - 1.) loosen riving knife bracket screw.
 - 2.) slide riving knife so it rests against fence.
 - 3.) secure riving knife bracket screw.
6. Raise riving knife and tighten pawls/riving knife knob.

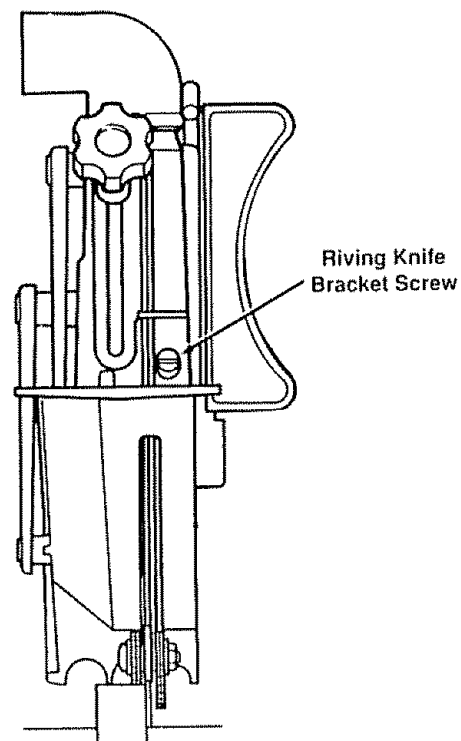
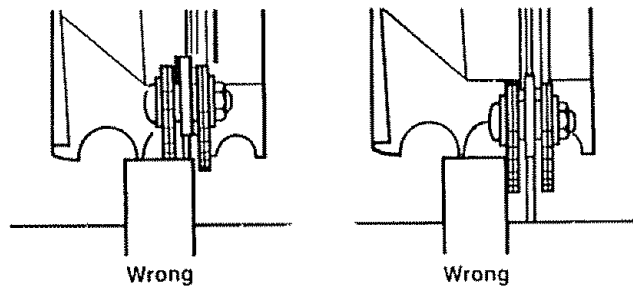
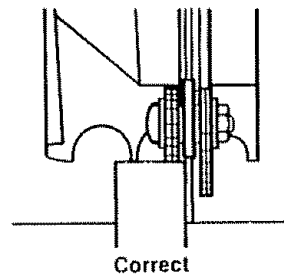

Controls

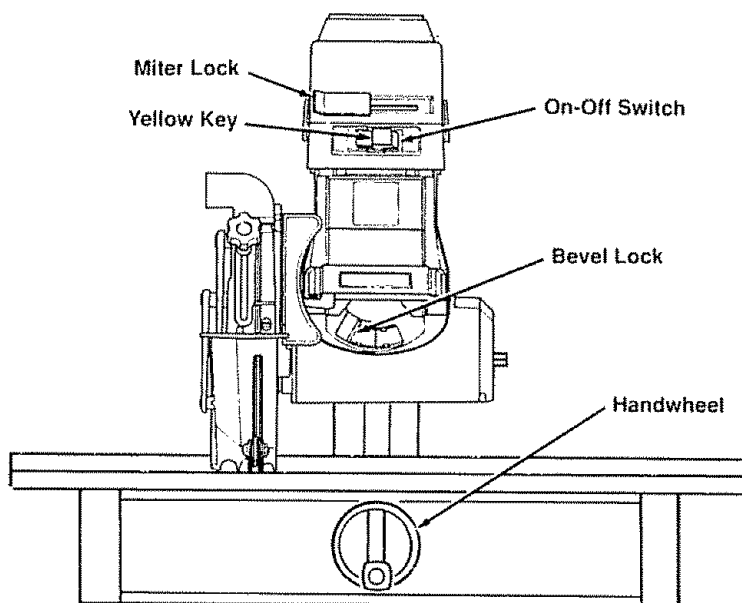

<u>Control</u>	<u>Function</u>	<u>Operation/Comments</u>
Miter Lock	Frees radial arm to move; locks in any desired position; pre-set indexed positions at 0°, 45°L, 45°R	Pull out and towards right to unlock, push to lock <i>Hold in unlocked position while moving arm</i>
On-Off Switch	Turns motor on/off	Pull on, push off <i>Requires yellow key</i>
Yellow Key	Allows saw to be switched on	Insert into on-off switch <i>Remove after turning saw off</i>
Bevel Lock	Frees motor to rotate; locks in any desired position; pre-set indexed positions at 0°, 45°, -45°, 90°, -90°	Move towards right to unlock, towards left to lock <i>Support motor before unlocking because it can swing down quickly. Hold in unlocked position while moving motor</i>
Handwheel	Raises/lowers radial arm	Turn clockwise to raise, counterclockwise to lower <i>To fold handle into wheel, squeeze red plastic ears and push handle; pull handle out until ears clock into place</i>
Table Lock (Cabinet Model -Not Illustrated)	Frees table sections to allow fence changing	Pull to unlock; push to lock

Controls

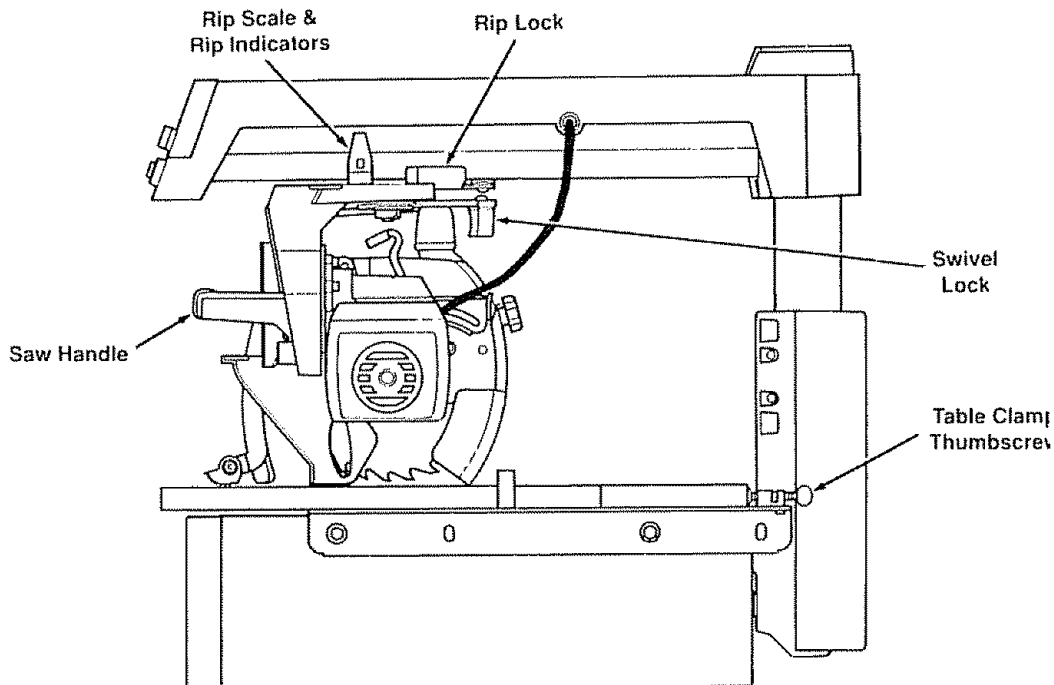

<u>Control</u>	<u>Function</u>	<u>Operation/Comments</u>
Rip Lock	Frees carriage to move along radial arm; locks in position	Pull to unlock, push to lock <i>Lock before ripping</i>
Rip Scale & Rip Indicators (Non-Electronic Models)	Tell distance between blade and fence when saw is in in-rip or out-rip position	Move blade carriage along arm to align line on indicator with desired number on scale
Swivel Lock	Frees blade carriage to rotate between rip and crosscut positions; locks in position	Pull to unlock; push to lock <i>Hold in unlocked position while moving blade carriage</i>
Table Clamp Thumbscrew (Leg Set Model)	Frees table sections to allow fence changing	Turn clockwise to tighten, counterclockwise to loosen
Saw Handle	Provides grasping surface so blade carriage can be moved. Contains trigger mechanism to raise clear plastic guard.	Grasp to move blade carriage. Squeeze trigger to raise clear plastic guard. <i>Clear guard must be raised over fence to start crosscut.</i>

Controls

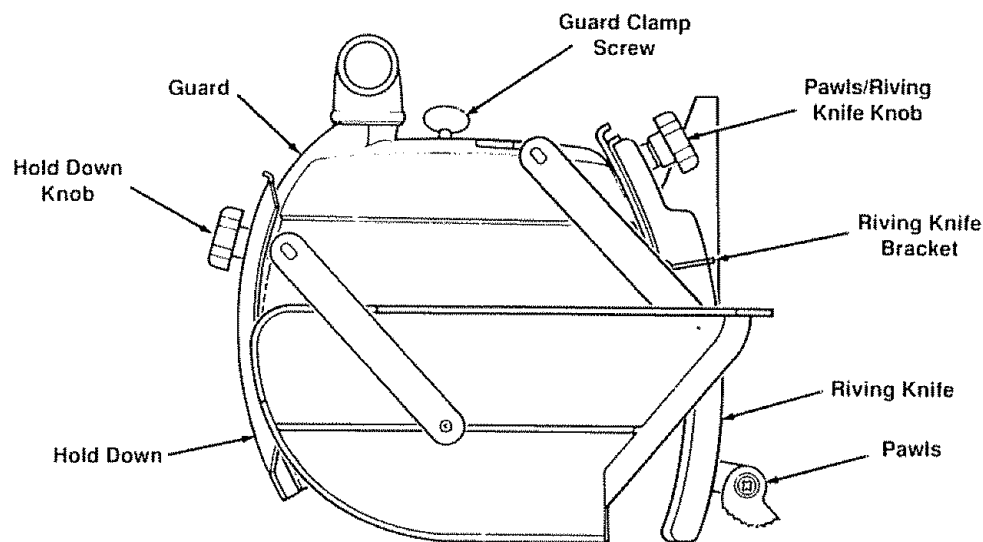

<u>Control</u>	<u>Function</u>	<u>Operation/Comments</u>
Guard Clamp Screw	Secures guard to motor; frees guard for removal	Turn counterclockwise to loosen, clockwise to tighten
Guard	Protects against contact with upper blade; partially protects against contact with lower blade; acts as sawdust deflector	Upper part remains fixed in level position. <i>Notch in guard fits securely into matching tab on motor</i> Clear guard is moveable: raise over fence at start of crosscut; <i>See Saw Handle</i> ; most workpieces will automatically raise clear guard during ripping; <i>See Guard Tab</i>
Hold Down Knob	Frees hold down to move up and down; locks hold down in place	Turn counterclockwise to loosen, clockwise to tighten
Hold Down	During ripping, acts as partial barrier to infeed side of blade; keeps infeed side of workpiece from fluttering; acts as sawdust deflector	For ripping, lower hold down to top of workpiece surface, then raise slightly and lock in place. For crosscutting lock in fully raised position
Riving Knife Bracket	Prevents side to side movement of riving knife and provides means for adjusting alignment	Loosen to align riving knife, then tighten

Controls

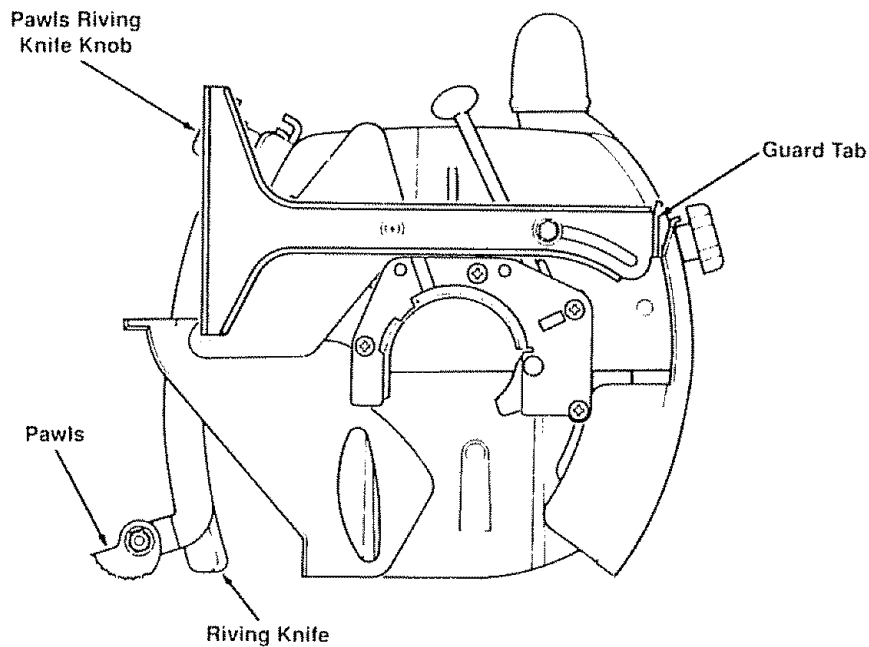

<u>Control</u>	<u>Function</u>	<u>Operation/Comments</u>
Guard Tab	Provides manual way to raise clear plastic guard during ripping when workpiece fails to raise it	Push and hold until workpiece clears guard, then release
Pawls/Riving Knife Knob	Frees pawls and riving knife to independently move up and down	Turn counterclockwise to loosen, clockwise to tighten
Pawls	During ripping, slow or stop kickback by digging into workpiece; when lowered during crosscutting, provide partial barrier to leading edge of blade	For ripping, set pawl level on workpiece surface. <i>For safety reasons set pawls before ripping; See Ripping Set-Up for details and illustrations</i>
Riving Knife	Reduces kickback by keeping kerf open; when lowered during crosscutting, provides partial barrier to leading edge of blade	For ripping, lower to table <i>For safety reasons riving knife must be in line with blade. See Alignment: Riving Knife to Blade</i>

Notes

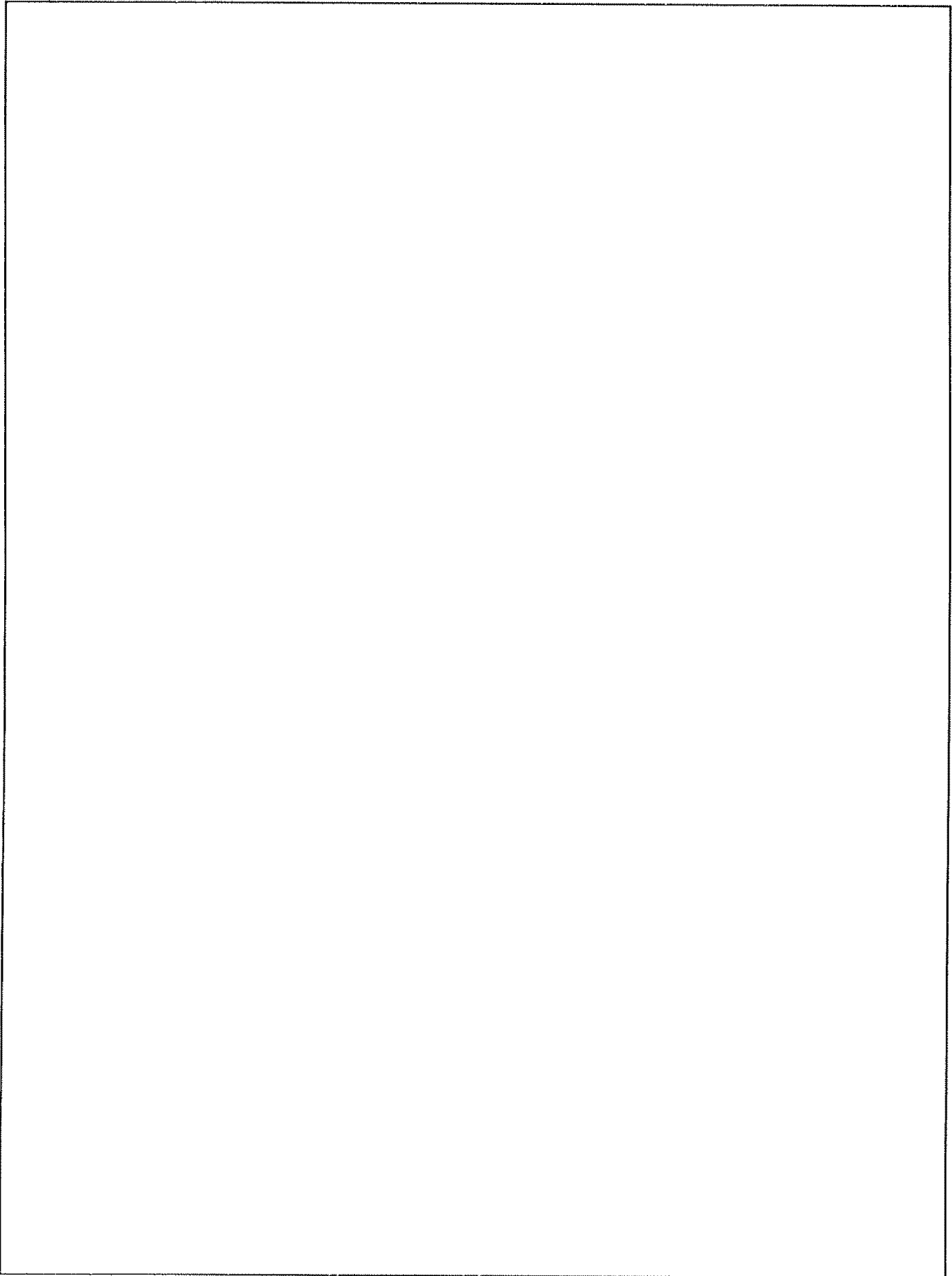

PARTS LIST CRAFTSMAN 10" RADIAL SAW GUARD KIT CATALOG 9-29012 & 9-29013

Always order by Part Number - Not by Key Number

FIGURE 1

Key No	Part No.	Description
1	818922-1	Screw, Flat Hd Plastite #10 x 3/4
2	820520	Handle, Yoke
3	820534	Spring
4	820533	Trigger
5	STD551008	* Washer, 3/16 x 3/8 x 1/32
6	346030	Screw Plastite #8 x 1/2
7	820516	Bumper
8	818169	Table Rear 40"
	815757	Table Rear 44"
9	820573	Table Spacer 40"
	820566	Table Spacer 44"
10	820572	Table Front 40"
	820568	Table Front 44"
11	818199	Table Support (29012 Only)
12	821560	Adapter Motor Key
13	STD600605	* Screw Pan HD Ty "T" 6-32 x 1/2
14	820985	Guard Accessory
15	805548-10	Washer 3/16 x 1 x 1/16
—	SP5623	Owners Manual (Not Shown)

* Standard Hardware Item - May Be Purchased Locally.

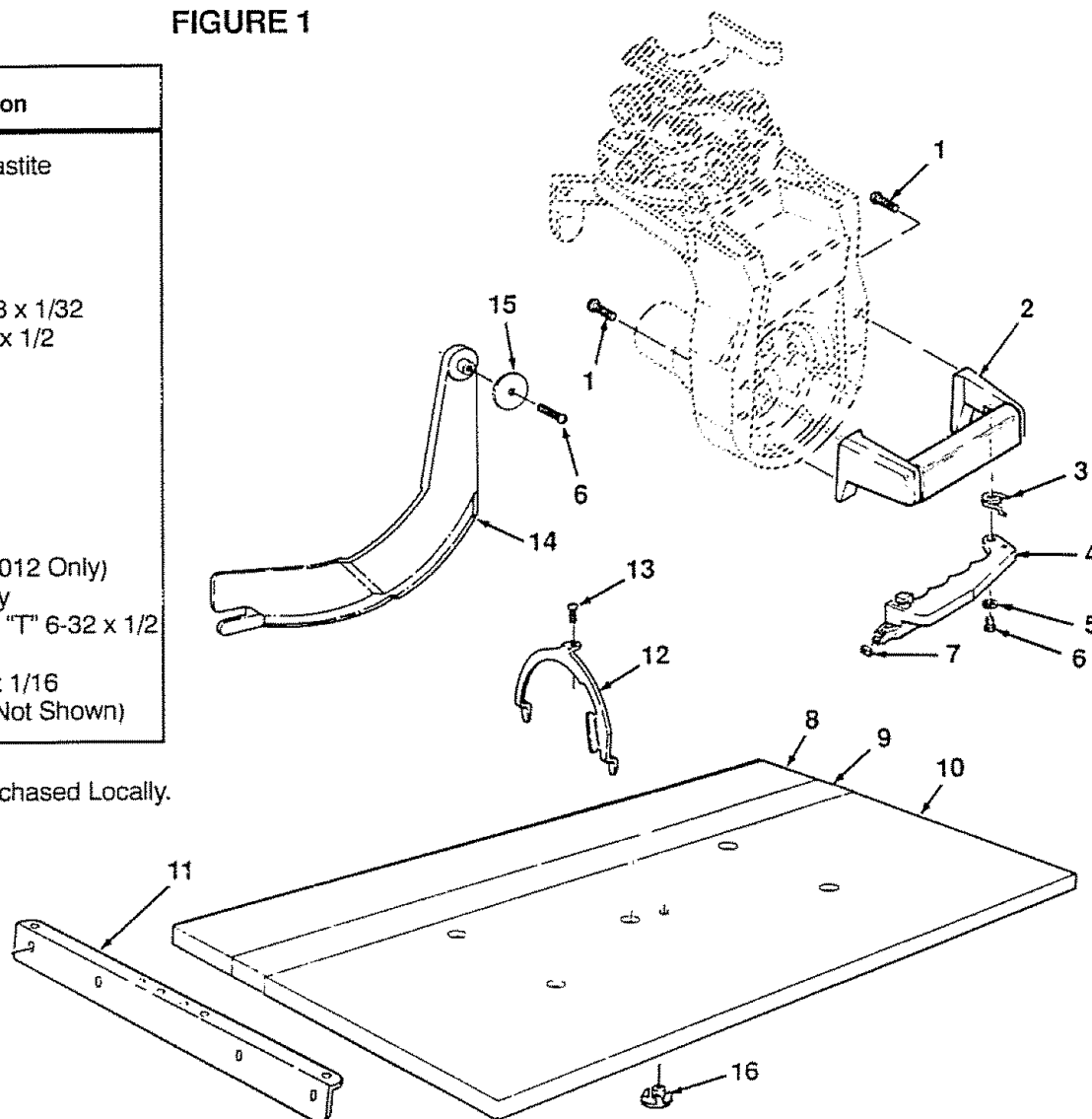

Repair Parts

PARTS LIST CRAFTSMAN 10" RADIAL SAW GUARD KIT
CATALOG 9-29012 & 9-29013

Always order by Part Number - Not by Key Number

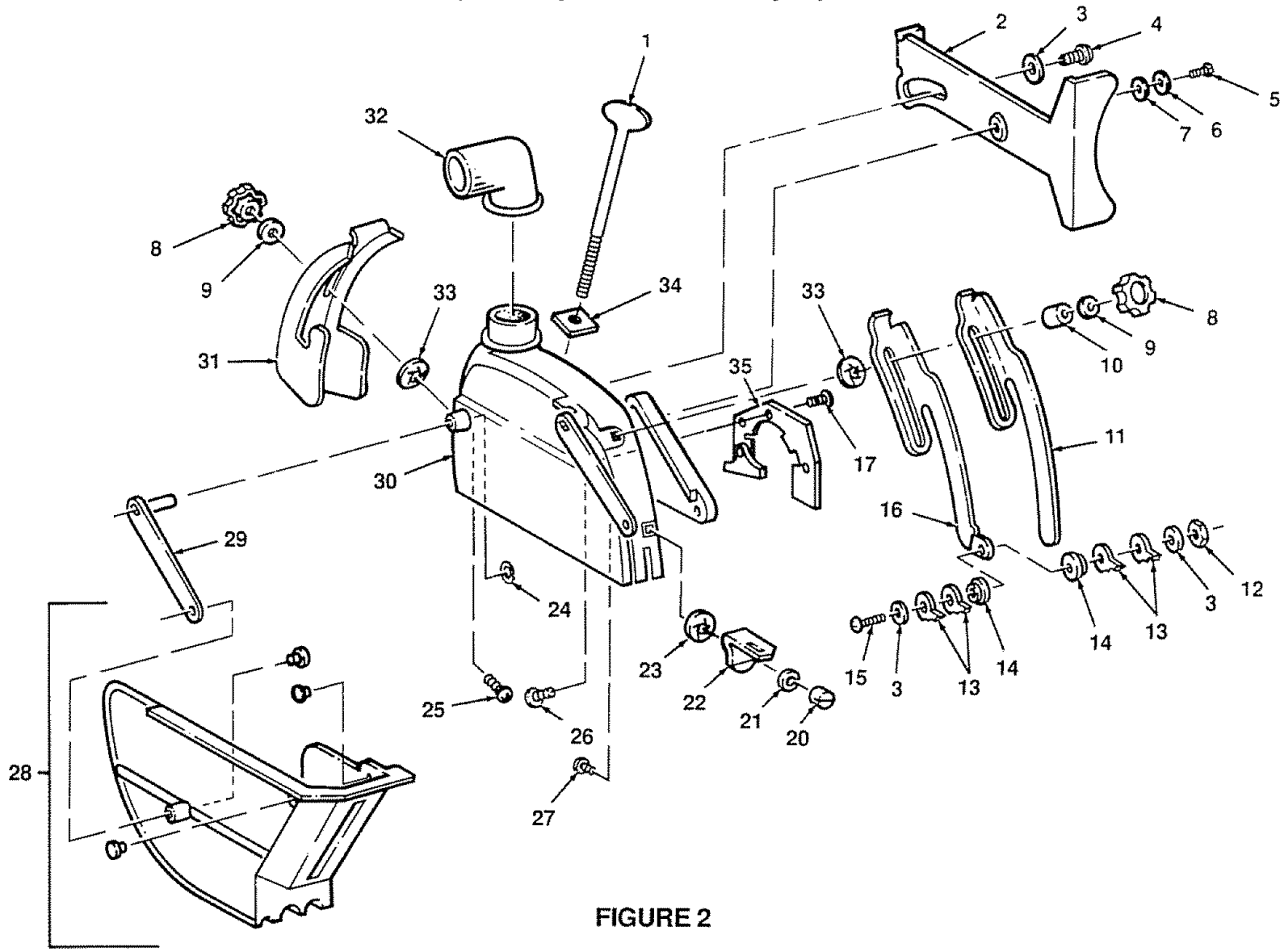

FIGURE 2

**PARTS LIST CRAFTSMAN 10" RADIAL SAW GUARD KIT
CATALOG 9-29012 & 9-29013**

Always order by Part Number - Not by Key Number

FIGURE 2 – GUARD

Key No	Part No.	Description
1	821217	Screw, Guard Clamp
2	821313	Link, Pull
3	STD551025	* Washer, 17/64 x 5/8 x 1/16
4	815865	Screw, Hex Washer Hd Type "TT" 1/4 - 20 x 1/2
5	STD601105	* Screw, Pan Hd Type "TT" 10-32 x 5/16
6	802392-47	Spacer #10 x .125
7	808447-6	Washer, Spring
8	820529	Knob, 5/16-18
9	STD551031	* Washer 21/64 x 5/8 x 1/16
10	820521	Spacer
11	820515	Knife, Riving
12	STD541425	* Nut, Lock 1/4-20
13	815815	Pawl, AKB
14	820517	Bushing
15	STD512510	* Screw, Pan Hd. 1/4-20 x 1
16	820512	Holder, AKB
17	824159	Screw, Flat Hd Type "TT" 1/4 - 20 x 9/16

Key No	Part No.	Description
20	820519	Nut, Slotted 1/4 - 20
21	STD551225	* Lockwasher 1/4
22	820530	Support, Knife
23	60208	Nut, Push 1/4
24	805641-1	* Ring, Retaining 5/16
25	STD533107	* Bolt, R.H. Short Neck 5/16 - 18 x 5/8
26	809019-4	Bolt, Rd Hd Short Neck 5/16 - 18 x 1-3/4
27	820532	Bolt 1/4 - 20 x 1/2
28	821310	Guard, Lower
29	821311	Link
30	821312	Guard
31	821314	Hold Down
32	63258	Elbow, Dust
33	60413	Nut, Push 5/16
34	821449	Nut, Square 5/16 - 18 Double Lead
35	824158	Strap-Retainer

* Standard Hardware Item – May Be Purchased Locally.

Repair Parts

SEARS

**owner's
manual
SERVICE**

**CATALOG NO.
9-29012
9-29013**

The model number of your drill press is found at the rear of the head

When requesting service or ordering parts, always provide the following information:

- Product Type
- Model Number
- Part Number
- Part Description

**10-INCH RADIAL SAW
GUARD KIT**

For the repair or replacement parts you need

Call 7 am - 7 pm, 7 days a week

1-800-366-PART
(1-800-366-7278)

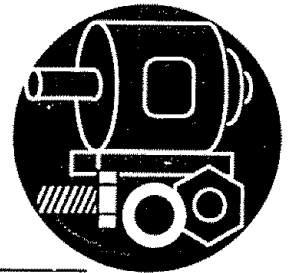

For in-home major brand repair service

Call 24 hours a day, 7 days a week

1-800-4-REPAIR
(1-800-473-7247)



**For the location of a
Sears Repair Service Center in your area**

Call 24 hours a day, 7 days a week

1-800-488-1222



**For information on purchasing a Sears
Maintenance Agreement or to inquire
about an existing Agreement**

Call 9 am - 5 pm, Monday-Saturday

1-800-827-6655



SEARS
REPAIR SERVICES

America's Repair Specialists

Sold by SEARS, ROEBUCK AND CO., Chicago, IL 60684 U.S.A.

Part No. SP5623

Form No. SP5623-3

Printed in U.S.A. 5/96