

# Microwave Oven

---

User manual

MC32K7058\*\*

---



**SAMSUNG**

# Contents

---

<b>Safety instructions</b>	<b>3</b>		
Important safety instructions	3	Using the healthy cooking features	20
Microwave function only	3	Using the dough proof/yogurt features	22
Oven function only - optional	5	Using the power defrost features	23
General safety	6	Using the auto reheat/cook features	25
Microwave operation precautions	7	Using the crusty plate	26
Limited warranty	8	Hot Blast	26
<b>Installation</b>	<b>8</b>	Grilling	27
Accessories	8	Choosing the accessories	28
Installation site	9	Combining microwaves and grill	28
Turntable	9	Combining microwaves and hot blast	29
<b>Maintenance</b>	<b>10</b>	Switching the beeper off	30
Cleaning	10	Using the child lock features	31
Replacement (repair)	10	Using the turntable on/off features	31
Care against an extended period of disuse	10	<b>Cooking guide</b>	<b>33</b>
<b>Oven features</b>	<b>11</b>	<b>Troubleshooting</b>	<b>44</b>
Oven	11	Troubleshooting	44
Control panel	11	Information code	47
<b>Oven use</b>	<b>12</b>	<b>Technical specifications</b>	<b>48</b>
How a microwave oven works	12		
Checking that your oven is operating correctly	12		
Setting the time	13		
Cooking/Reheating	13		
Power levels and time variations	14		
Adjusting the cooking time	14		
Stopping the cooking	15		
Setting the energy save mode	15		
Using the hot blast auto features	15		
Using the slim fry features	18		

## Safety instructions

---

### IMPORTANT SAFETY INSTRUCTIONS

---

READ CAREFULLY AND KEEP FOR FUTURE REFERENCE.

#### MICROWAVE FUNCTION ONLY

---

**WARNING:** If the door or door seals are damaged, the oven must not be operated until it has been repaired by a competent person.

**WARNING:** It is hazardous for anyone other than a competent person to carry out any service or repair operation that involves the removal of a cover which gives protection against exposure to microwave energy.

**WARNING:** Liquids and other foods must not be heated in sealed containers since they are liable to explode.

**WARNING:** Only allow children to use the oven without supervision when adequate instructions have been given so that the child is able to use the oven in a safe way and understands the hazards of improper use.

This appliance is intended to be used in household only and it is not intended to be used such as:

- staff kitchen areas in shops, offices and other working environments;
- farm houses;

- by clients in hotels, motels and other residential environments;
- bed and breakfast type environments.

Only use utensils that are suitable for use in microwave ovens. When heating food in plastic or paper containers, keep an eye on the oven due to the possibility of ignition.

Metallic containers for food and beverages are not allowed during microwave cooking.

The microwave oven is intended for heating food and beverages. Drying of food or clothing and heating of warming pads, slippers, sponges, damp cloth and similar may lead to risk of injury, ignition or fire.

If smoke is observed (emitted), switch off or unplug the appliance and keep the door closed in order to stifle any flames.

Microwave heating of beverages can result in delayed eruptive boiling, therefore care must be taken when handling the container.

The contents of feeding bottles and baby food jars shall be stirred or shaken and the temperature checked before consumption, in order to avoid burns.

## Safety instructions

---

Eggs in their shell and whole hard-boiled eggs should not be heated in microwave ovens since they may explode, even after microwave heating has ended.

The oven should be cleaned regularly and any food deposits removed.

Failure to maintain the oven in a clean condition could lead to deterioration of the surface that could adversely affect the life of the appliance and possibly result in a hazardous situation.

The microwave oven is intended to be used on the counter top (freestanding) use only, the microwave oven shall not be placed in a cabinet.

The appliance should not be cleaned with a water jet.

The appliance is not intended for installing in road vehicles, caravans and similar vehicles etc.

This appliance is not intended for use by persons (including children) with reduced physical, sensory or mental capabilities, or lack of experience and knowledge, unless they have been given supervision or instruction concerning use of the appliance by a person responsible for their safety.

Children should be supervised to ensure that they do not play with the appliance.

This appliance can be used by children aged from 8 years and above and persons with reduced physical, sensory or mental capabilities or lack of experience and knowledge if they have been given supervision or instruction concerning use of the appliance in a safe way and understand the hazards involved. Children shall not play with the appliance. Cleaning and user maintenance shall not be made by children without supervision. If the supply cord is damaged, it must be replaced by the manufacturer, its service agent or similarly qualified persons in order to avoid a hazard.

This oven should be positioned proper direction and height permitting easy access to cavity and control area.

Before using the your oven first time, oven should be operated with the water during 10 minute and then used.

If the oven generates a strange noise, a burning smell, or smoke is emitted, unplug the power plug immediately and contact your nearest service center.

The microwave oven has to be positioned so that plug is accessible.

---

## OVEN FUNCTION ONLY - OPTIONAL

---

**WARNING:** When the appliance is operated in the combination mode, children should only use the oven under adult supervision due to the temperatures generated.

During use the appliance becomes hot. Care should be taken to avoid touching heating elements inside the oven.

**WARNING:** Accessible parts may become hot during use. Young children should be kept away.

A steam cleaner is not to be used.

Do not use harsh abrasive cleaners or sharp metal scrapers to clean the oven door glass since they can scratch the surface, which may result in shattering of the glass.

**WARNING:** Ensure that the appliance is switched off before replacing the lamp to avoid the possibility of electric shock.

Do not use harsh abrasive cleaners or sharp metal scrapers to clean the oven door glass since they can scratch the surface, which may result in shattering of the glass.

**WARNING:** The appliance and its accessible parts become hot during use.

Care should be taken to avoid touching heating elements.

---

Children less than 8 years of age shall be kept away unless continuously supervised.

This appliance can be used by children aged from 8 years and above and persons with reduced physical, sensory or mental capabilities or lack of experience and knowledge if they have been given supervision or instruction concerning use of the appliance in a safe way and understand the hazards involved. Children shall not play with the appliance. Cleaning and user maintenance shall not be made by children without supervision. The door or the outer surface may get hot when the appliance is operating.

The temperature of accessible surfaces may be high when the appliance is operating.

The appliances are not intended to be operated by means of an external timer or separate remote-control system.

## Safety instructions

This appliance can be used by children aged from 8 years and above and persons with reduced physical, sensory or mental capabilities or lack of experience and knowledge if they have been given supervision or instruction concerning use of the appliance in a safe way and understand the hazards involved. Children shall not play with the appliance. Cleaning and user maintenance shall not be made by children unless they are older than 8 and supervised.

Keep the appliance and its cord out of reach of children less than 8 years.

### General safety

Any modifications or repairs must be performed by qualified personnel only.

Do not heat food or liquids sealed in containers for the microwave function.

Do not use benzene, thinner, alcohol, or steam or high-pressure cleaners to clean the oven.

Do not install the oven: near a heater or flammable material; locations that are humid, oily, dusty or exposed to direct sunlight or water; or where gas may leak; or an uneven surface.

This oven must be properly grounded in accordance with local and national codes. Regularly use a dry cloth to remove foreign substances from the power plug terminals and contacts.

Do not pull, excessively bend, or place heavy objects on the power cord.

If there is a gas leak (propane, LP, etc) ventilate immediately. Do not touch the power cord.

Do not touch the power cord with wet hands.

While the oven is operating, do not turn it off by unplugging the power cord.

Do not insert fingers or foreign substances. If foreign substances enter the oven, unplug the power cord and contact a local Samsung service centre.

Do not apply excessive pressure or impact to the oven.

Do not place the oven over fragile objects.

Ensure the power voltage, frequency, and current matches the product specifications.

Firmly plug the power plug into the wall socket. Do not use multiple plug adapters, extension cords, or electric transformers.

Do not hook the power cord on metal objects. Make sure the cord is between objects or behind the oven.

Do not use a damaged power plug, power cord, or loose wall socket. For damaged power plugs or cords, contact a local Samsung service centre.

Do not pour or directly spray water onto the oven.

Do not place objects on the oven, inside, or on the oven door.

Do not spray volatile materials such as insecticide on the oven.

Do not store flammable materials in the oven. Because alcohol vapours can contact hot parts of the oven, use caution when heating food or drinks containing alcohol.

Children may bump themselves or catch their fingers on the door. When opening/closing the door, keep children away.

### Microwave warning

Microwave heating of beverages may result in delayed eruptive boiling; always use caution when handling the container. Always allow beverages to stand at least 20 seconds before handling. If necessary, stir during heating. Always stir after heating.

In the event of scalding, follow these First Aid instructions:

1. Immerse the scalded area in cold water for at least 10 minutes.
2. Cover with a clean, dry dressing.
3. Do not apply any creams, oils, or lotions.

To avoid damaging the tray or rack, do not put the tray or rack in water shortly after cooking.

Do not use the oven for deep fat frying because the oil temperature cannot be controlled. This could result in a sudden boil over of hot oils.

### Microwave oven precautions

Only use microwave-safe utensils. Do not use metallic containers, gold or silver trimmed dinnerware, skewers, etc.

Remove wire twist ties. Electric arcing may occur.

Do not use the oven to dry papers or clothes.

Use shorter times for small amounts of food to prevent overheating or burning.

Keep the power cord and power plug away from water and heat sources.

To avoid the risk of explosion, do not heat eggs with shells or hard-boiled eggs. Do not heat airtight or vacuum-sealed containers, nuts, tomatoes, etc.

Do not cover the ventilation slots with cloth or paper. This is a fire hazard. The oven may overheat and turn off automatically and will remain off until it cools sufficiently.

Always use oven mitts when removing a dish.

Stir liquids halfway during heating or after heating ends and allow the liquid stand at least 20 seconds after heating to prevent eruptive boiling.

Stand at arms length from the oven when opening the door to avoid getting scalded by escaping hot air or steam.

Do not operate the oven when it is empty. The oven will automatically shut down for 30 minutes for safety purposes. We recommend placing a glass of water inside the oven at all times to absorb microwave energy in case the oven is started accidentally.

Install the oven in compliance with the clearances in this manual. (See Installing your microwave oven.)

Use caution when connecting other electrical appliances to sockets near the oven.

### Microwave operation precautions

Failure to observe the following safety precautions may result in harmful exposure to microwave energy.

- Do not operate the oven with the door open. Do not tamper with the safety interlocks (door latches). Do not insert anything into the safety interlock holes.
- Do not place any object between the oven door and front face or allow food or cleaner residue to accumulate on sealing surfaces. Keep the door and door sealing surfaces clean by wiping with a damp cloth and then with a soft, dry cloth after each use.
- Do not operate the oven if it is damaged. Only operate after it has been repaired by a qualified technician.  
**Important:** the oven door must close properly. The door must not be bent; the door hinges must not be broken or loose; the door seals and sealing surfaces must not be damaged.
- All adjustments or repairs must be done by a qualified technician.

## Limited warranty

Samsung will charge a repair fee for replacing an accessory or repairing a cosmetic defect if the damage to the unit or accessory was caused by the customer. Items this stipulation covers include:

- Door, handles, out-panel, or control panel that are dented, scratched, or broken.
- A broken or missing tray, guide roller, coupler, or wire rack.

Use this oven only for its intended purpose as described in this instruction manual. Warnings and Important Safety Instructions in this manual do not cover all possible conditions and situations that may occur. It is your responsibility to use common sense, caution, and care when installing, maintaining, and operating your oven.

Because these following operating instructions cover various models, the characteristics of your microwave oven may differ slightly from those described in this manual and not all warning signs may be applicable. If you have any questions or concerns, contact a local Samsung service centre or find help and information online at [www.samsung.com](http://www.samsung.com).

Use this oven for heating food only. It is intended for domestic use only. Do not heat any type of textiles or cushions filled with grains. The manufacturer cannot be held liable for damage caused by improper or incorrect use of the oven.

To avoid deterioration of the oven surface and hazardous situations, always keep the oven clean and well maintained.

## Installation

### Accessories

Depending on the model that you have purchased, you are supplied with several accessories that can be used in a variety of ways.

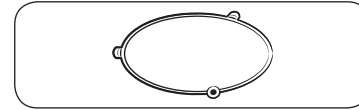

**01 Roller ring**, to be placed in the centre of the oven.

**Purpose:** The roller ring supports the turntable.

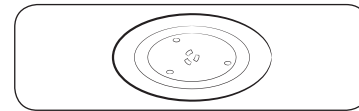

**02 Turntable**, to be placed on the roller ring with the centre fitting on to the coupler.

**Purpose:** The turntable serves as the main cooking surface; it can be easily removed for cleaning.

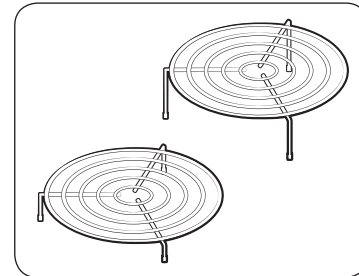

**03 High rack, Low rack**, to be placed on the turntable.

**Purpose:** The metal racks can be used to cook two dishes at the same time. A small dish may be placed on the turntable and a second dish on the rack. **The metal racks can be used in grill, hot blast and combination cooking.**

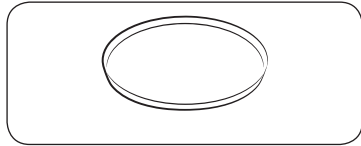

#### 04 Crusty plate, see page 26.

**Purpose:** The crusty plate is used to brown food better in the microwave or grill combination cooking modes. It helps keep pastry and pizza dough crisp.

#### CAUTION

**DO NOT** operate the microwave oven without the roller ring and turntable.

### Installation site

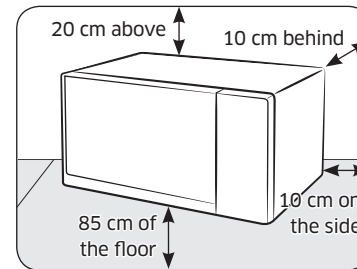

- Select a flat, level surface approx. 85 cm above the floor. The surface must support the weight of the oven.
- Secure room for ventilation, at least 10 cm from the rear wall and both sides, and 20 cm from above.
- Do not install the oven in hot or damp surroundings, such as next to other microwave ovens or radiators.
- Conform to the power supply specifications of this oven. Use only approved extension cables if you need to use.
- Wipe the interior and the door seal with a damp cloth before using your oven for the first time.

### Turntable

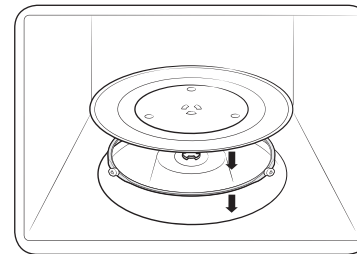

Remove all packing materials inside the oven. Install the roller ring and turntable. Check that the turntable rotates freely.

# Maintenance

## Cleaning

Clean the oven regularly to prevent impurities from building up on or inside the oven. Also pay special attention to the door, door sealing, and turntable and roller ring (applicable models only).

If the door won't open or close smoothly, first check if the door seals have built up impurities. Use a soft cloth in soapy water to clean both the inner and outer sides of the oven. Rinse and dry well.

### To remove stubborn impurities with bad smells from inside the oven

1. With an empty oven, put a cup of diluted lemon juice on the centre of the turntable.
2. Heat the oven for 10 minutes at max power.
3. When the cycle is complete, wait until the oven cools down. Then, open the door and clean the cooking chamber.

### To clean inside swing-heater models

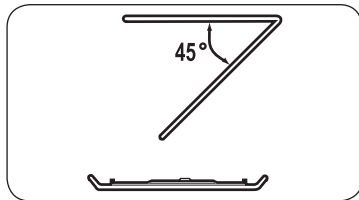

To clean the upper area of the cooking chamber, lower the top heating element by 45° as shown. This will help clean the upper area. When done, reposition the top heating element.

### ⚠ CAUTION

- Keep the door and door sealing clean and ensure the door opens and closes smoothly. Otherwise, the oven's lifecycle may be shortened.
- Take caution not to spill water into the oven vents.
- Do not use any abrasive or chemical substances for cleaning.
- After each use of the oven, use a mild detergent to clean the cooking chamber after waiting for the oven to cool down.

## Replacement (repair)

### ⚠ WARNING

This oven has no user-removable parts inside. Do not try to replace or repair the oven yourself.

- If you encounter a problem with hinges, sealing, and/or the door, contact a qualified technician or a local Samsung service centre for technical assistance.
- If you want to replace the light bulb, contact a local Samsung service centre. Do not replace it yourself.
- If you encounter a problem with the outer housing of the oven, first unplug the power cord from the power source, and then contact a local Samsung service centre.

### Care against an extended period of disuse

If you don't use the oven for an extended period of time, unplug the power cord and move the oven to a dry, dust-free location. Dust and moisture that builds up inside the oven may affect the performance of the oven.

# Oven features

## Oven

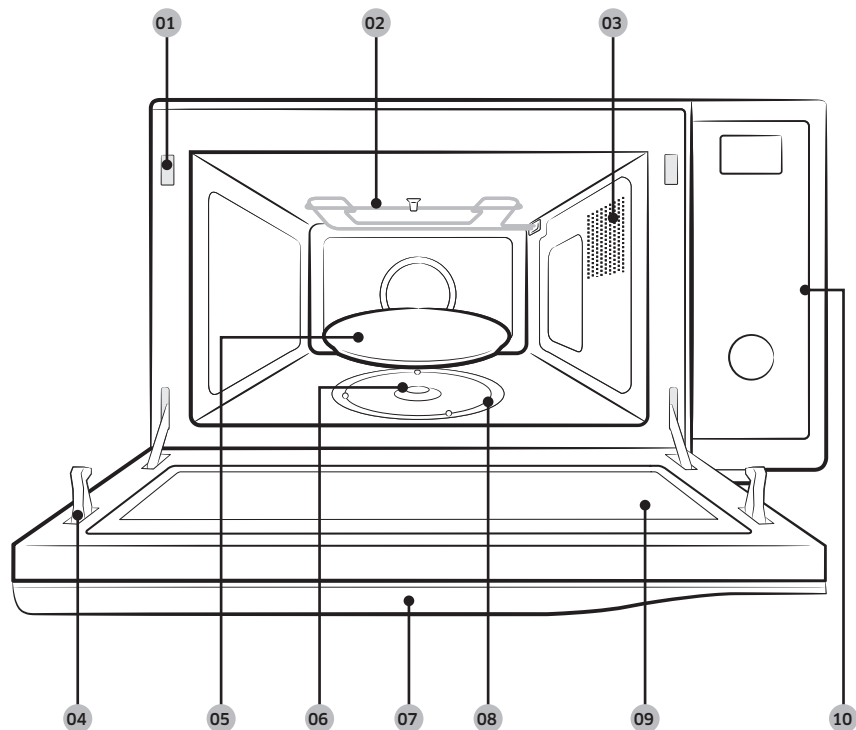

- 01 Safety interlock holes
- 02 Heating element
- 03 Ventilation holes
- 04 Door latches
- 05 Turntable
- 06 Coupler
- 07 Door handle
- 08 Roller ring
- 09 Door
- 10 Control panel

## Control panel

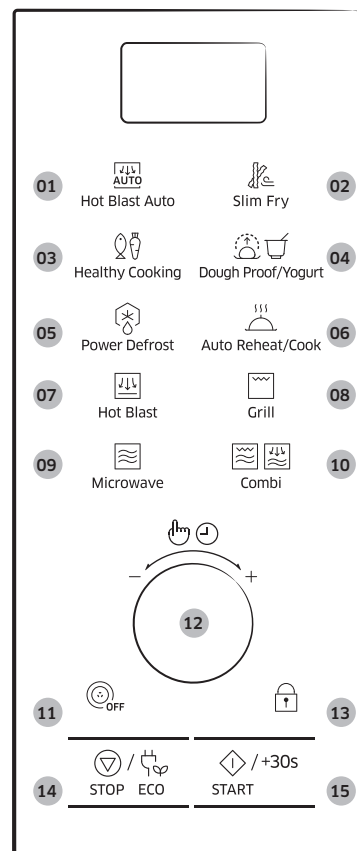

- 01 Hot Blast Auto Button
- 02 Slim Fry Button
- 03 Healthy Cooking Button
- 04 Dough Proof/Yogurt Button
- 05 Power Defrost Button
- 06 Auto Reheat/Cook Button
- 07 Hot Blast Button
- 08 Grill Button
- 09 Microwave Button
- 10 Combi Button
- 11 Turntable On/Off Button
- 12 Multi Function Selector Dial
- 13 Child Lock Button
- 14 Stop/Eco Button
- 15 Start/+30s Button

Oven features

# Oven use

## How a microwave oven works

Microwaves are high-frequency electromagnetic waves; the energy released enables food to be cooked or reheated without changing either the form or the colour.

You can use your microwave oven to:

- Defrost
- Reheat
- Cook

Cooking principle.

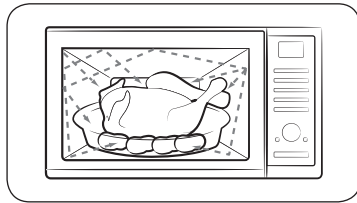

1. The microwaves generated by the magnetron reflected at cavity and are distributed uniformly as the food rotates on the turntable. The food is thus cooked evenly.
2. The microwaves are absorbed by the food up to a depth of about 1 inch (2.5 cm). Cooking then continues as the heat is dissipated within the food.
3. Cooking times vary according to the container used and the properties of the food:
  - Quantity and density
  - Water content
  - Initial temperature (refrigerated or not)

### IMPORTANT

As the centre of the food is cooked by heat dissipation, cooking continues even when you have taken the food out of the oven. Standing times specified in recipes and in this booklet must therefore be respected to ensure:

- Even cooking of the food right to the centre.
- The same temperature throughout the food.

## Checking that your oven is operating correctly

The following simple procedure enables you to check that your oven is working correctly at all times. If you are in doubt, refer to the section entitled “Troubleshooting” on the page 44-47.

### NOTE

The oven must be plugged into an appropriate wall socket. The turntable must be in position in the oven. If a power level other than the maximum (100 % - 900 W) is used, the water takes longer to boil.

Open the oven door by pulling the handle on the upper side of the door. Place a glass of water on the turntable. Close the door.

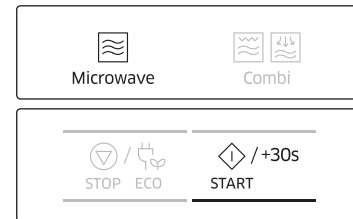

Press the Microwave mode and set the time to 4 or 5 minutes by pressing the **START/+30s** button.

**Result:** The oven heats the water for 4 or 5 minutes. The water should then be boiling.

## Setting the time

When power is supplied, “88:88” and then “12:00” is automatically displayed on the display.

Please set the current time. The time can be displayed in either the 24-hour or 12-hour notation. You must set the clock:

- When you first install your microwave oven
- After a power failure

### NOTE

Do not forget to reset the clock when you switch to and from summer and winter time.

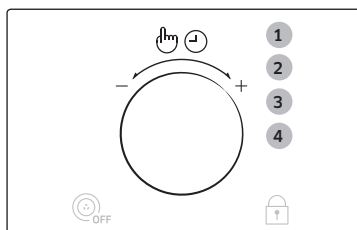

1. Press the **Multi Function Selector Dial**.
2. Turn the **Multi Function Selector Dial** to set time display type. (12H or 24H)
3. Press the **Multi Function Selector Dial** to complete the setup.
4. Turn the **Multi Function Selector Dial** to set the hour.

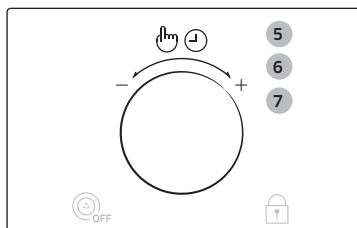

5. Press the **Multi Function Selector Dial**.
6. Turn the **Multi Function Selector Dial** to set the minute.
7. When the right time is displayed, press the **Multi Function Selector Dial** to start the clock.

**Result:** The time is displayed whenever you are not using the microwave oven.

## Cooking/Reheating

The following procedure explains how to cook or reheat food.

### IMPORTANT

ALWAYS check your cooking settings before leaving the oven unattended.

Open the door. Place the food in the centre of the turntable. Close the door. Never switch the microwave oven on when it is empty.

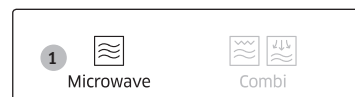

1. Press the **Microwave** button.  
**Result:** The following indications are displayed:

 (Microwave mode)  
900 W (Output power)

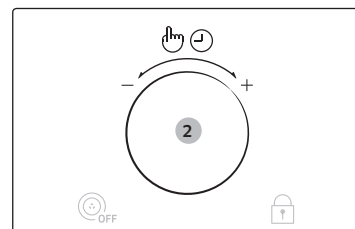

2. Turn the **Multi Function Selector Dial** until the appropriate power level is displayed.  
At that time, press the **Multi Function Selector Dial** to set the power level.
  - If don't set the power level within 5 seconds, Automatically changes to the cooking time setting stage.

# Oven use

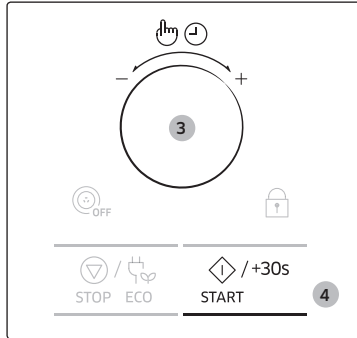

- Set the cooking time by turning the **Multi Function Selector Dial**.  
**Result:** The cooking time is displayed.
- Press the **START/+30s** button.  
**Result:** The oven light comes on and the turntable starts rotating. Cooking starts. When it has finished.
  - The oven beeps 4 times.
  - The end reminder signal will beep 3 times (once every minute).
  - The current time is displayed again.

## Power levels and time variations

The power level function enables you to adapt the amount of energy dissipated and thus the time required to cook or reheat your food, according to its type and quantity.

You can choose between six power levels.

Power level	Percentage	Output
HIGH	100 %	900 W
MEDIUM HIGH	67 %	600 W
MEDIUM	50 %	450 W
MEDIUM LOW	33 %	300 W
DEFROST	20 %	180 W
LOW	11 %	100 W

The cooking times given in recipes and in this booklet correspond to the specific power level indicated.

If you select a...	Then the cooking time must be...
Higher power level	Decreased
Lower power level	Increased

## Adjusting the cooking time

You can increase the cooking time by pressing the **START/+30s** button once for each 30 seconds to be added.

- Check how cooking is progressing at any time simply by opening the door
- Increase the remaining cooking time

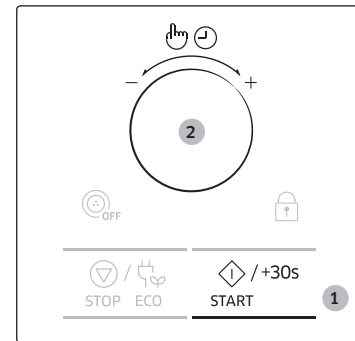

### Method 1

To increase the cooking time of your food during cooking, press the **START/+30s** button once for each 30 seconds that you wish to add.

- Example: To add three minutes, press the **START/+30s** button six times.

### Method 2

Just turning **Multi Function Selector Dial** to adjust cooking time.

- To increase cooking time, turn to right and to decrease cooking time, turn to left.

## Stopping the cooking

You can stop cooking at any time so that you can:

- Check the food
- Turn the food over or stir it
- Leave it to stand

To stop the cooking...	Then...
Temporarily	Open the door or press the <b>STOP/ECO</b> button once. <b>Result:</b> Cooking stops. To resume cooking, close the door again and press the <b>START/+30s</b> button.
Completely	Press the <b>STOP/ECO</b> button once. <b>Result:</b> Cooking stops. If you wish to cancel the cooking settings, press the <b>STOP/ECO</b> button again.

## Setting the energy save mode

The oven has an energy save mode.



- Press the **STOP/ECO** button.  
**Result:** Display off.
- To remove energy save mode, open the door or press the **STOP/ECO** button and then display shows current time. The oven is ready for use.

### NOTE

#### Auto energy saving function

If you do not select any function when appliance is in the middle of setting or operating with temporary stop condition, function is canceled and clock will be displayed after 25 minutes.

Oven Lamp will be turned off after 5 minutes with door open condition.

## Using the hot blast auto features

The 10 **Hot Blast Auto** features include/provide pre-programmed cooking times. You do not need to set either the cooking times or the power level. You can adjust the size of the serving by turning the **Multi Function Selector Dial**.

### IMPORTANT

Use only recipients that are microwave-safe.

Open the door. Place the food in the centre of the turntable. Close the door.

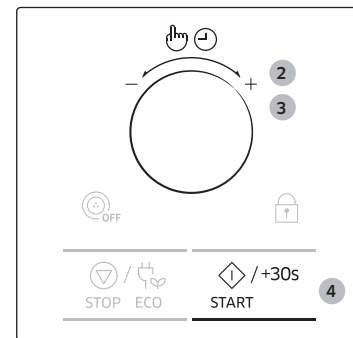
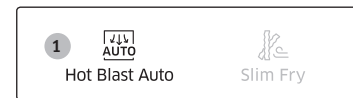

1. Press the **Hot Blast Auto** button.

2. Select the type of food that you are cooking by turning the **Multi Function Selector Dial**.

Refer to the table on the following page for a description of the various pre-programmed settings. At that time, press the **Multi Function Selector Dial** to select the type of food.

3. Select the size of the serving by turning the **Multi Function Selector Dial**.

4. Press the **START/+30s** button.

**Result:** The food is cooked according to the pre-programmed setting selected. When it has finished.

- 1) The oven beeps 4 times.
- 2) The end reminder signal will beep 3 times (once every minute).
- 3) The current time is displayed again.

# Oven use

## Hot Blast guide

The following table presents 10 **Hot Blast auto** programmes, quantities, standing times and appropriate recommendations. Those programmes are running with a combination of microwaves, grill and convection heater.

Code	Food	Serving size	Recommendations
H1	Frozen Pan Pizza	400-450 g	Remove a package and place the Pizza on a Low rack. After cooking, stand for 2-3 minutes.
H2	Salmon steaks	200-250 g 300-350 g	Put fish steaks evenly on crusty plate on the high rack. Brush a bit oil on surface. Turnover as soon as the beep sounds. After cooking, stand for 2 minutes.
H3	Homemade Lasagne	500-600 g 1000-1100 g	<ul style="list-style-type: none"> <li>Ingredients (1000-1100 g) 2 tbsp olive oil, 300 g minced beef, 200 g tomato sauce, 100 ml beef stock, 150 g dried lasagne sheets (8 sheets), 1 onion(chopped), 1 tsp each of dried parsley flakes, oregano, basil, 200g grated mozzarella cheese</li> <li>- In case of 500-600 g, use half quantity.</li> <li>Method Sauce: Heat the oil in a frying pan, then cook the minced beef and chopped onion for about 10 min until browned all over. Pour over the tomato sauce and beef stock, add the dried herbs. Bring up to the boil, then simmer for 30 min. Cook lasagna noodles according to package directions. Layer noodle, meat sauce, and cheese then repeat. Then sprinkle evenly with remaining mozzarella cheese on the top of noodles and put them in the low rack. After cooking, stand for 2-3 minutes.</li> </ul>

Code	Food	Serving size	Recommendations
H4	Homemade Gratin	500-600 g 900-1000 g	<ul style="list-style-type: none"> <li>Ingredients (900-1000 g) 640 g potatoes, 80 ml milk, 80 ml cream, 40 g beaten whole egg, 1 tsp each of salt, pepper, nutmeg, 120 g grated mozzarella cheese, butter, thyme</li> <li>- In case of 500-600 g, Use half quantity.</li> <li>Method Peel potatoes and slice them to 3 mm thickness. Rub the butter all over the surface of a gratin dish. Spread the slices on a clean towel and keep them covered with the towel while you prepare the rest of the ingredients. Mix the rest of the ingredients except for grated cheese into a large bowl and stir well. Layer the potato slices in the dish slightly overlapping and pour the mixture over the potatoes. Spread the grated cheese over the top and put them in the low rack. After cooking, serve sprinkled with a few fresh thyme leaves. After cooking, stand for 2-3 minutes.</li> </ul>
H5	Frozen French Fries	200-250 g 300-350 g	Distribute frozen oven chips evenly on the crusty plate. Set plate on the high rack. After cooking, stand for 2-3 minutes.
H6	Frozen Buffalo Wings	400-450 g 500-550 g	Put the Frozen Buffalo wings (pre-cooked and spiced) on a side of the crusty plate. Set plate on the high rack. After cooking, stand for 2-3 minutes.

Code	Food	Serving size	Recommendations
H7	Roast Chicken Pieces	500-600 g 900-1000 g	Weigh chicken pieces and brush with oil and spices. Place them evenly on high rack. When the beep sounds, turn the chicken over and press start to continue. After cooking, stand for 2-3 minutes.
H8	Roast Chicken	1100-1200 g 1200-1300 g	Brush the chicken oil and spices fully. Put breast side up on the low rack. After cooking, stand for 2-3 minutes.
H9	Beef Steak Pie	500-600 g	<ul style="list-style-type: none"> <li>Ingredients 200 g beef, cubed, 1 tbsp olive oil, 1/2 onion(sliced), 80 g mushroom(sliced), 1 tbsp each of parsley and thyme, chopped, 1 tbsp Worcestershire sauce, salt and pepper 2 tbsp flour, 100 ml hot beef stock, 120 g ready-made pastry dough, 1 egg yolk, beaten</li> <li>Method Sprinkle the beef with flour, salt and pepper. Fry them in a frying pan with oil, stirring frequently until browned. Add onion, mushroom, parsley, thyme, Worcestershire sauce and beef stock and broil. After broiling, reduce to simmer for an hour. Pour the filling mixture to an oven dish and cover with the pie pastry sheet and press the edge together to seal. Decorate with pastry trimming with knife and fork. Cut across the top and brush with beaten egg yolk. Put them on the low rack. After cooking, stand for 2-3 minutes.</li> </ul>

Code	Food	Serving size	Recommendations
H10	Homemade Mini Quiche	400-500 g	<ul style="list-style-type: none"> <li>Ingredients Pastry 200 g plain flour, 80 g butter, 1 egg, 30 g bacon, cubed, 60 g Cream, 60 g Cream fraiche, 2 egg, 40 g grated cheese, salt and pepper</li> <li>Method To make the pastry, put the flour, butter and eggs in a bowl and mix to a soft pastry and then rest it in the refrigerator for 30 mins. Roll out the pastry and place in buttered metal tins (like muffin mould for 6 mini quiches). Mix the cream, cubed bacon, cream fraiche, egg, cheese, salt, pepper and pour the mixture into the moulds. Put them on the low rack. After cooking, stand for 5 minutes.</li> </ul>

# Oven use

## Using the slim fry features

The 11 **Slim Fry** features include/provide pre-programmed cooking times. You do not need to set either the cooking times or the power level. You can adjust the Slim Fry category by turning the **Multi Function Selector Dial**.

### IMPORTANT

Use only recipients that are microwave-safe.

Open the door. Place the food in the centre of the turntable. Close the door.



1. Press the **Slim Fry** button.

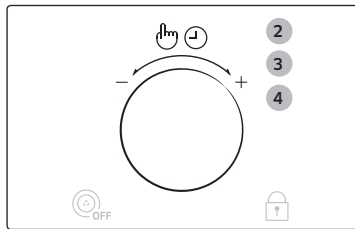

2. Turn the **Multi Function Selector Dial** to select Cook category. At that time, press the **Multi Function Selector Dial** to select the cook category.
  1. Potatoes/Vegetables
  2. Seafood
  3. Chicken
3. Select the type of food that you are cooking by turning the **Multi Function Selector Dial**. Refer to the table on the following page for a description of the various pre-programmed settings. At that time, press the **Multi Function Selector Dial** to select the type of food.
4. Select the size of the serving by turning the **Multi Function Selector Dial**.



5. Press the **START/+30s** button.

**Result:** The food is cooked according to the pre-programmed setting selected. When it has finished.

- 1) The oven beeps 4 times.
- 2) The end reminder signal will beep 3 times (once every minute).
- 3) The current time is displayed again.

### Slim fry guide

The following table presents the 11 **Slim Fry** auto programmes for frying. It contains its quantities and appropriate instructions. You will use less oil compared to frying with oil fryer, while you will get tasty results. Programmes are running with a combination of convection, top heater and microwave energy.

#### 1. Potatoes/Vegetables

Code	Food	Serving size	Recommendations
1-1	Frozen Potato Croquettes	200-250 g 300-350 g	Distribute frozen potato croquettes evenly on the crusty plate. Set plate on low rack. Stand for 1-2 minutes.
1-2	Homemade French Fries	300-350 g 400-450 g	Use hard to medium type of potatoes and wash them. Peel potatoes and cut into sticks with a thickness of 10 x 10 mm. Soak in cold water (for 30 min.). Dry them with a towel, weigh them and brush with 5 g olive oil. Distribute homemade fries evenly on the crusty plate. Set plate on high rack. Stand for 1-2 minutes.

Code	Food	Serving size	Recommendations
1-3	Potato Wedges	200-250 g 300-350 g 400-450 g	Wash normal sized potatoes and cut them into wedges. Brush with olive oil and spices. Put them with the cut side on the crusty plate. Set plate on high rack. Stand for 1-3 minutes.
1-4	Frozen Onion Ring	100-150 g 200-250 g	Put frozen breaded onion rings or frozen breaded squid rings evenly on the crusty plate. Set plate on low rack. Stand for 1-2 minutes.
1-5	Sliced Courgettes	100-150 g 200-250 g	Rinse and slice courgettes. Brush with 5 g olive oil and add spices. Put slices evenly on the crusty plate and set plate on high rack. Turnover after beep sounds. Press start to continue. (The oven keeps operating if you do not turn over). Stand for 1-2 minutes.

## 2. Seafood

Code	Food	Serving size	Recommendations
2-1	Frozen Prawns	200-250 g 300-350 g	Distribute frozen breaded prawns evenly on the crusty plate. Set plate on low rack. Stand for 1-2 minutes.
2-2	Frozen Fish Cutlets	200-250 g 300-350 g	Distribute frozen breaded fish cutlets evenly on the crusty plate. Set plate on low rack. Stand for 1-2 minutes.
2-3	Frozen Fried Squid	100-150 g 200-250 g	Distribute frozen breaded squid rings evenly on the crusty plate. Set plate on low rack. Stand for 1-2 minutes.

## 3. Chicken

Code	Food	Serving size	Recommendations
3-1	Frozen Chicken Nuggets	200-250 g 300-350 g	Distribute frozen chicken nuggets evenly on the crusty plate. Set plate on high rack. Stand for 1-2 minutes.
3-2	Chicken Drumsticks	200-250 g 300-350 g 400-450 g	Weigh drumsticks and brush with oil and spices. Distribute chicken drumsticks evenly on the crusty plate. Set plate on high rack. Turnover after beep sounds, oven will stop process. Press start to continue. Stand for 1-3 minutes.
3-3	Chicken Wings	200-250 g 300-350 g	Weigh chicken wings and brush with oil and spices. Distribute chicken wings evenly on the crusty plate. Set plate on high rack. Turnover after beep sounds, oven will stop process. Press start to continue. Stand for 1-2 minutes.

# Oven use

## Using the healthy cooking features

The 13 **Healthy Cooking** features provide pre-programmed cooking times. You do not need to set either the cooking times or the power level. You can adjust the size of the serving by turning the **Multi Function Selector Dial**.

### IMPORTANT

Use only recipients that are microwave-safe. Open the door. Place the food in the centre of the turntable. Close the door.

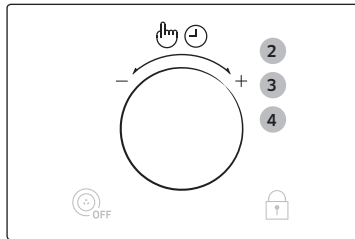
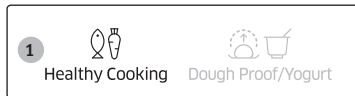

1. Press the **Healthy Cooking** button.
2. Select the category of food by turning the **Multi Function Selector Dial** and press the **Multi Function Selector Dial**.
  1. Grain/Pasta
  2. Vegetables
  3. Poultry/Fish
3. Select the type of food that you are cooking by turning the **Multi Function Selector Dial**. Refer to the table on the following page for a description of the various pre-programmed settings. At that time, press the **Multi Function Selector Dial** to select the type of food.
4. Select the size of the serving by turning the **Multi Function Selector Dial**.



5. Press the **START/+30s** button.
 

**Result:** The food is cooked according to the pre-programmed setting selected. When it has finished.

  - 1) The oven beeps 4 times.
  - 2) The end reminder signal will beep 3 times (once every minute).
  - 3) The current time is displayed again.

## Healthy cooking guide

The following table presents quantities and appropriate instructions about 13 **Healthy Cooking** programmes.

### 1. Grain/Pasta

Code	Food	Serving size	Recommendations
1-1	Brown Rice	150-200 g 200-250 g	Use a large glass ovenware dish with lid. Add cold water of double quantity. Cook covered. Stir before standing time and add salt and herbs. Stand for 5-10 minutes.
1-2	Quinoa	150-200 g 200-250 g	Use a large glass ovenware dish with lid. Add cold water of double quantity. Cook covered. Stir before standing time and add salt and herbs. Stand for 1-3 minutes.
1-3	Macaroni	100-150 g 200-250 g	Use a large glass ovenware dish with lid. Add hot boiling water of 4 times, a pinch of salt and stir well. Cook uncovered. Stir before standing time and drain thoroughly afterwards. Stand for 1-3 minutes.

## 2. Vegetables

Code	Food	Serving size	Recommendations
2-1	Broccoli Florets	200-250 g 450-500 g	Weigh the broccoli after washing. Cutting into similar size. (width 5 cm, length 5 cm, height 1 cm) Put 2-4 tbsp. water in glass bowl. Distribute broccoli (steam part up) well in glass bowl. Cover with plastic wrap. After cooking, Stand for 2-3 minutes.
2-2	Green Beans	200-250 g 300-350 g	Rinse and clean green beans. Put them evenly into a glass bowl with lid. Add 30 ml (2 tbsp) water when cooking for 200-250 g and add 45ml (3 tbsp) for 300-450 g. Put bowl in the center of turntable. Cook covered. Stir after cooking. Stand for 1-2 minutes.
2-3	Spinach	100-150 g 200-250 g	Rinse and clean spinach. Put into a glass bowl with lid. Do not add water. Put bowl in the center of turntable. Cook covered. Stir after cooking. Stand for 1-2 minutes.
2-4	Peeled Potatoes	300-350 g 400-450 g 500-550 g	Wash and peel potatoes, cut into halves and put into a glass bowl with lid. Add 15-30 ml of water (1-2 tbsp). Stir after cooking. When cooking higher quantities stir once during cooking. Stand for 3-5 minutes.
2-5	Grilled Eggplants	100-150 g 200-250 g	Rinse and slice eggplants. Brush with oil and spices. Put slices evenly on the high rack. Turnover after beep sounds. Press start to continue (The oven keeps operating if you do not turnover). Stand for 1-2 minutes.

Code	Food	Serving size	Recommendations
2-6	Grilled Tomatoes	400-450 g 600-650 g	Rinse and clean tomatoes. Cut them into halves and put in an ovenware dish. Add grated cheese on top. Put dish on the high rack. Stand for 1-2 minutes.

## 3. Poultry/Fish

Code	Food	Serving size	Recommendations
3-1	Chicken Breasts	300-350 g 400-450 g	Rinse chicken breast and put on deep glass ovenware dish. Cover with microwave cling film and pierce film. Put dish on the turntable. Stand for 2 minutes.
3-2	Turkey Breasts	300-350 g 400-450 g	Rinse turkey breast and put on deep glass ovenware dish. Cover with microwave cling film and pierce film. Put dish on the turntable. Stand for 2 minutes.
3-3	Grilled Fish Fillets	200-300 g 400-500 g	Put fish fillets on the crusty plate. Set plate on high rack. Turnover as soon as the beep sounds. Stand for 1-2 minutes.
3-4	Roast Fish	300-350 g 400-450 g	Brush skin of whole fish (trout or gilthead) with oil and add herbs and spices. Put fish side by side, head to tail on the high rack. Turnover as soon as the beep sounds. Stand for 3 minutes.

# Oven use

## Using the dough proof/yogurt features

The 5 **Dough Proof/Yogurt** features include/provide pre-programmed cooking times. You do not need to set either the cooking times or the power level. You can adjust the dough proof/yogurt category by turning the **Multi Function Selector Dial** after press the **Dough Proof/Yogurt** button.

First, place the food in the centre of the turntable and close the door.

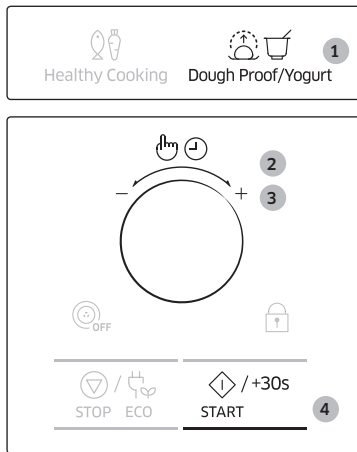

1. Press the **Dough Proof/Yogurt** button.
2. Select the Dough Proof or Homemade Yogurt and press the **Multi Function Selector Dial**.
  1. Dough Proof
  2. Homemade Yogurt
3. Select the type of food that you are cooking by turning the **Multi Function Selector Dial**. Refer to the table on the following page for a description of the various pre-programmed settings.
4. Press the **START/+30s** button.

### IMPORTANT

Turntable is not operating during yogurt cooking.

## Dough proof/yogurt guide

The following table presents how to use the auto programmes for rising yeast dough or homemade yogurt.

### 1. Dough Proof

Code	Food	Serving size	Recommendations
1-1	Pizza Dough	300-500 g	Put dough in suitable sized bowl and set on the low rack. Cover with aluminium foil.
1-2	Cake Dough	500-800 g	Put dough in suitable sized bowl and set on the low rack. Cover with aluminium foil.
1-3	Bread Dough	600-900 g	Put dough in suitable sized bowl and set on the low rack. Cover with aluminium foil.

## 2. Homemade Yogurt

Code	Food	Serving size	Recommendations
2-1	Small Cups	500 g	Distribute 150 g natural yogurt into 5 ceramic cups or small glass jars evenly (30 g each). Add 100 ml milk into each cup. Use long-life milk (room-temperature; 3.5 % fat). Cover each with cling film and set in a circle on turntable. After finish, keep 6 hours in a refrigerator. For the first time we recommend to use dried yoghurt bacteria ferment.
2-2	Large Bowl	500 g	Mix 150 g natural yogurt with 500 ml long-life milk (room-temperature; 3.5 % fat). Pour evenly into large glass bowl. Cover with cling film and set on turntable. After finish, keep 6 hours in a refrigerator. For the first time we recommend to use dried yoghurt bacteria ferment.

## Using the power defrost features

The **Power Defrost** features enable you to defrost meat, poultry, fish, bread, cake and fruit. The defrost time and power level are set automatically. You simply select the programme and the weight.

### NOTE

Use only recipients that are microwave-safe.

Open the door. Place the food in the centre of the turntable. Close the door.

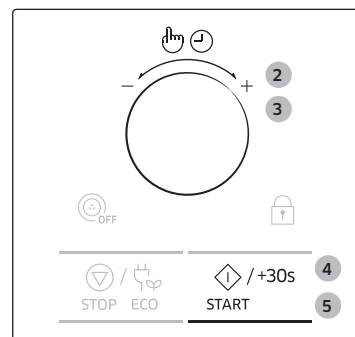

1. Press the **Power Defrost** button.
  2. Select the type of food that you are cooking by turning the **Multi Function Selector Dial**. Refer to the table on the following page for a description of the various pre-programmed settings. At that time, press the **Multi Function Selector Dial** to select the type of food.
  3. Select the size of the serving by turning the **Multi Function Selector Dial**.
  4. Press the **START/+30s** button.
- Result:**
- Defrosting begins.
  - The oven beeps through defrosting to remind you to turn the food over.
5. Press the **START/+30s** button again to finish defrosting.

**Result:** When it has finished.

- 1) The oven beeps 4 times.
- 2) The end reminder signal will beep 3 times (once every minute).
- 3) The current time is displayed again.

# Oven use

## Power defrost guide

The following table presents the various **Power Defrost** programmes, quantities and appropriate instructions. Remove all kind of package material before defrosting. Place meat, poultry and fish on a flat glass plate or on a ceramic plate, arrange bread, cake and fruit on kitchen paper.

Code	Food	Serving size	Recommendations
1	Meat	200-1500 g	Shield the edges with aluminium foil. Turn the meat over, when the oven beeps. This programme is suitable for beef, lamb, pork, steaks, chops, minced meat. Stand for 20-60 minutes.
2	Poultry	200-1500 g	Shield the leg and wing tips with aluminium foil. Turn the poultry over, when the oven beeps. This programme is suitable for whole chicken as well as for chicken portions. Stand for 20-60 minutes.
3	Fish	200-1500 g	Shield the tail of a whole fish with aluminium foil. Turn the fish over, when the oven beeps. This programme is suitable for whole fishes as well as for fish fillets. Stand for 20-50 minutes.

Code	Food	Serving size	Recommendations
4	Bread/Cake	125-1000 g	Put bread horizontally on a piece of kitchen paper and turn over, as soon as the oven beeps. Place cake on a ceramic plate and if possible, turn over, as soon as the oven beeps. (Oven keeps operating and is stopped, when you open the door.) This programme is suitable for all kinds of bread, sliced or whole, as well as for bread rolls and baguettes. Arrange bread rolls in a circle. This programme is suitable for all kinds of yeast cake, biscuit, cheese cake and puff pastry. It is not suitable for short/crust pastry, fruit and cream cakes as well as for cake with chocolate topping. Stand for 10-30 minutes.
5	Fruit	100-600 g	Spread fruits evenly into a flat glass dish. This programme is suitable for all kind of fruits. Stand for 5-20 minutes.

## Using the auto reheat/cook features

The 5 **Auto Reheat/Cook** features include/provide pre-programmed cooking times. You do not need to set either the cooking times or the power level.

You can adjust the size of the serving by turning the **Multi Function Selector Dial**.

### 🔊 IMPORTANT

Use only recipients that are microwave-safe.

Open the door. Place the food in the centre of the turntable. Close the door.

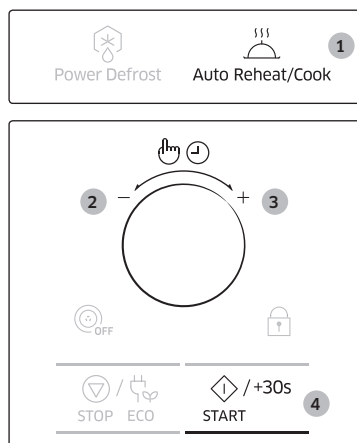

1. Press the **Auto Reheat/Cook** button.
2. Select the type of food that you are cooking by turning the **Multi Function Selector Dial**. Refer to the table on the following page for a description of the various pre-programmed settings. At that time, press the **Multi Function Selector Dial** to select the type of food.
3. Select the size of the serving by turning the **Multi Function Selector Dial**.
4. Press the **START/+30s** button.

**Result:** The food is cooked according to the pre-programmed setting selected. When it has finished.

- 1) The oven beeps 4 times.
- 2) The end reminder signal will beep 3 times (once every minute).
- 3) The current time is displayed again

## Auto reheat/cook guide

The following table presents quantities and appropriate instructions for auto reheat and cook.

Code	Food	Serving size	Recommendations
1	Ready Meal (Chilled)	300-350 g 400-450 g	Put on a ceramic plate and cover with microwave cling film. This program is suitable for meals consisting of 3 components (e.g. meat with sauce, vegetables and a side dish like potatoes, rice or pasta). Stand for 2-3 minutes.
2	Frozen Pizza	300-350 g 400-450 g	Put frozen pizza on the low rack. After cooking, Stand for 2-3 minutes.
3	Frozen Lasagne	400-450 g 600-650 g	Put frozen lasagne into a suitable sized ovenproof dish. Put dish on the turntable. After cooking, stand for 3-4 minutes.
4	Quiche (Chilled)	600-650 g	This program is suitable for refrigerated quiche. Remove a package and put on the dish. Place on the low rack. After cooking, stand for 1-2 minutes.
5	Roast Chicken	1100-1200 g 1200-1300 g	Brush chilled chicken with oil and spices. Put breast-side-down, in the middle of the low rack. Turnover, as soon as the oven beeps. Push <b>Start</b> button to continue process. Stand for 5 minutes.

# Oven use

## Using the crusty plate

This crusty plate allows you to brown food not only on the top with the grill, but also the bottom of the food turns crispy and brown due to the high temperature of the crusty plate. Several items which you can prepare on the crusty plate can be found in the chart (see next page). The crusty plate can also be used for bacon, eggs, sausages, etc.

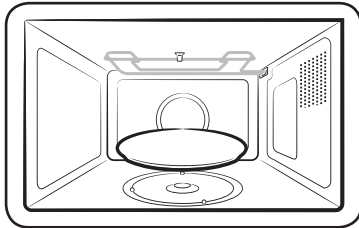

1. Place the crusty plate directly on the turntable and preheat it with highest Microwave-Grill-Combination [600 W + Grill] by following the times and instructions in the chart.
2. Brush the plate with oil if you are cooking food, such as bacon and eggs, in order to brown the food nicely.
3. Place the food on the crusty plate.
4. Place the crusty plate on the metal rack (or turntable) in the microwave.
5. Select the appropriate cooking time and power. (Refer to the table on the side)

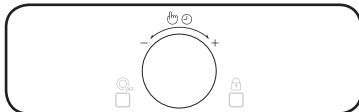
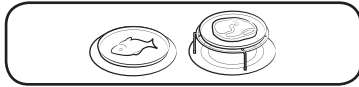

### ⚠ CAUTION

- Always use oven gloves to take out the crusty plate, as will become very hot.
- Do not place any objects on the crusty plate that are not heat-resistant.
- Never place the crusty plate in the oven without turntable.
- Please note that the crust plate is not dish washer-safe.

### 📖 NOTE

- Please note that the crusty plate has a teflon layer which is not scratch-resistant. Do not use any sharp objects like a knife to cut on the crusty plate.
- Clean the crusty plate with warm water and detergent and rinse off with clean water.
- Do not use a scrubbing brush or a hard sponge otherwise the top layer will be damaged.

## Hot Blast

Hot Blast mode is similar to traditional oven. The microwave mode is not used. You can set the temperature, as required, in a range varying from 40 °C to 200 °C. The maximum cooking time is 60 minutes.

- Always use oven gloves when touching the recipients in the oven, as they will be very hot.
- You can get better cooking and browning, if you use the low rack.

Open the door and place the recipient on the low rack and set on turntable.



1. Press the **Hot Blast** button.

**Result:** The following indications are displayed:

 (Hot blast mode)  
180 °C (Temperature)

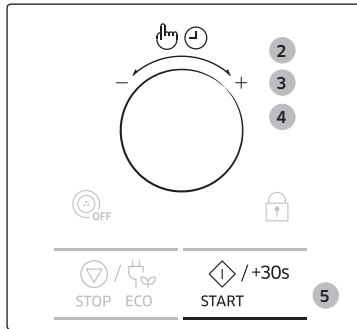

2. Set the temperature by turning the **Multi Function Selector Dial**.  
(Temperature : 40-200 °C, 10 °C interval)
  - If don't set the temperature within 5 seconds, Automatically changes to the cooking time setting stage.
3. Press the **Multi Function Selector Dial**.
4. Set the cooking time by turning the **Multi Function Selector Dial**.  
(If you want to preheat the oven, select “ : 0”)
5. Press the **START/+30s** button.

- Result:** Cooking starts. When it has finished.
- 1) The oven beeps 4 times.
  - 2) The end reminder signal will beep 3 times (once every minute).
  - 3) The current time is displayed again.

## Grilling

The grill enables you to heat and brown food quickly, without using microwaves.

- Always use oven gloves when touching the recipients in the oven, as they will be very hot.
- You can get better cooking and grilling results, if you use the high rack.

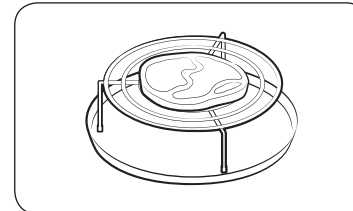

1. Open the door and place the food on the rack.

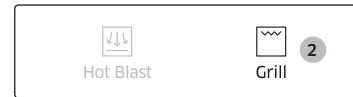

2. Press the **Grill** button.  
**Result:** The following indications are displayed:  
 (Grill mode)
  - You cannot set the temperature of the grill.

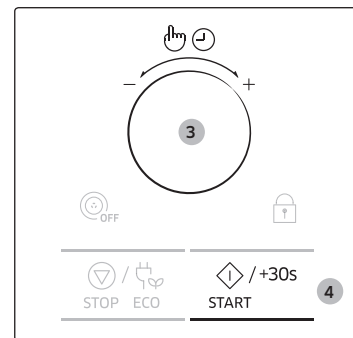

3. Set the grilling time by turning the **Multi Function Selector Dial**.
  - The maximum grilling time is 60 minutes.
4. Press the **START/+30s** button.  
**Result:** Grilling starts. When it has finished.
  - 1) The oven beeps 4 times.
  - 2) The end reminder signal will beep 3 times (once every minute).
  - 3) The current time is displayed again.

# Oven use

## Choosing the accessories

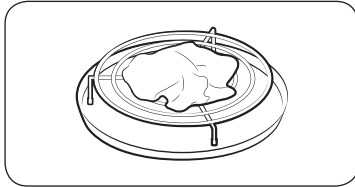

Traditional oven cooking does require cookware. You should, however, use only cookware that you would use in your normal oven.

Microwave-safe containers are not usually suitable for convection cooking; don't use plastic containers, dishes, paper cups, towels, etc.

If you wish to select a combined cooking mode (microwave and grill or hot blast), use only recipients that are microwave-safe and oven-proof.

### IMPORTANT

For further details on suitable cookware and utensils, refer to the Cookware guide on page 32.

## Combining microwaves and grill

You can also combine microwave cooking with the grill, to cook quickly and brown at the same time.

### IMPORTANT

ALWAYS use microwave-safe and oven-proof cookware. Glass or ceramic dishes are ideal as they allow the microwaves to penetrate the food evenly.

### IMPORTANT

ALWAYS use oven gloves when touching the recipients in the oven, as they will be very hot.

You can improve cooking and grilling, if you use the high rack.

Open the door. Place the food on the rack best suited to the type of food to be cooked. Place the rack on the turntable. Close the door.



1. Press the **Combi** button.

**Result:** The following indications are displayed:

Cb-1 (Microwave + Grill)

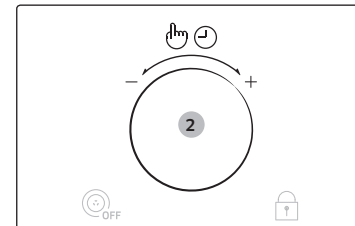

2. Make the display indicating Cb-1, and then press the **Multi Function Selector Dial**.

**Result:** The following indications are displayed:

 (Microwave & Grill combi mode)

450 W (Output power)

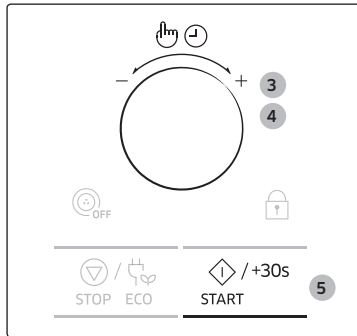

3. Select the appropriate power level by turning the **Multi Function Selector Dial** until the corresponding output power is displayed (450, 300 W). At that time, press the **Multi Function Selector Dial** to set the power level.
  - You cannot set the temperature of the grill.
  - If don't set the temperature within 5 seconds, Automatically changes to the cooking time setting stage.
4. Set the cooking time by turning the **Multi Function Selector Dial**.
  - The maximum cooking time is 60 minutes.
5. Press the **START/+30s** button.

- Result:** Combination cooking starts. When it has finished.
- 1) The oven beeps 4 times.
  - 2) The end reminder signal will beep 3 times (once every minute).
  - 3) The current time is displayed again.

## Combining microwaves and hot blast

Combination cooking uses both microwave energy and hot blast heating. No preheating is required as the microwave energy is immediately available. Many foods can be cooked in combination mode, particularly:

- Roast meats and poultry
- Pies and cakes
- Egg and cheese dishes

### IMPORTANT

ALWAYS use microwave-safe and oven-proof cookware. Glass or ceramic dishes are ideal as they allow the microwaves to penetrate the food evenly.

### IMPORTANT

ALWAYS use oven gloves when touching the recipients in the oven, as they will be very hot. You can get better cooking and browning, if you use the low rack. Open the door. Place the food on the turntable or on the low rack which should then be placed on the turntable. Close the door. The heating element must be in the horizontal position.



1. Press the **Combi** button.  
**Result:** The following indications are displayed:  
Cb-1 (Microwave + Grill)

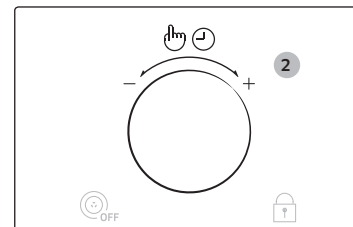

2. Make the display indicating Cb-2 (Microwave + Hot blast) by turning the **Multi Function Selector Dial**, and then press the Multi Function Selector Dial.  
**Result:** The following indications are displayed:  
 (Microwave & Hot blast combi mode)  
 450 W (Output power)

# Oven use

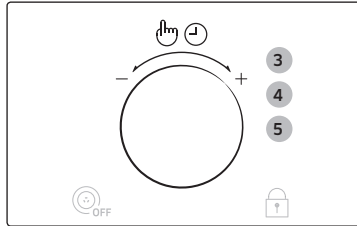

3. Select the appropriate power level by turning the **Multi Function Selector Dial** until the corresponding output power is displayed (450, 300, 180, 100 W). At that time, press the **Multi Function Selector Dial** to set the power level.
  - If don't set the power level within 5 seconds, Automatically changes to the cooking time setting stage. (Default : 450 W)

**Result:** The following indications are displayed:

 (Microwave & Hot blast combi mode)  
 180 °C (Temperature)

4. Select the appropriate temperature by turning the **Multi Function Selector Dial** (Temperature : 200-40 °C). At that time, press the **Multi Function Selector Dial** to set the power level.
  - If don't set the temperature within 5 seconds, Automatically changes to the cooking time setting stage. (Default : 180 °C)
5. Set the cooking time by turning the **Multi Function Selector Dial**.
  - The maximum cooking time is 60 minutes.



6. Press the **START/+30s** button.
 

**Result:** Combination cooking starts. The oven is heated to the required temperature and then microwave cooking continues until the cooking time is over. When it has finished.

  - 1) The oven beeps 4 times.
  - 2) The end reminder signal will beep 3 times (once every minute).
  - 3) The current time is displayed again.

## Switching the beeper off

You can switch the beeper off whenever you want.

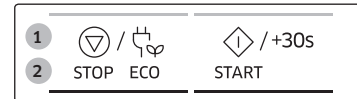

1. Press the **START/+30s** and **STOP/ECO** button at the same time.
 

**Result:** The oven does not beep to indicate the end of a function.

  - The following indications are displayed.
2. To switch the beeper back on, press the **START/+30s** and **STOP/ECO** button again at the same time.
 

**Result:** The oven operates normally.

  - The following indications are displayed.





## Using the child lock features

Your microwave oven is fitted with a special child lock programme, which enables the oven to be “locked” so that children or anyone unfamiliar with it cannot operate it accidentally.

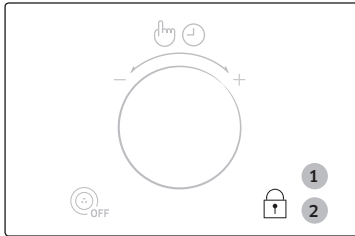

1. Press the **Child Lock** button for 3 second.

**Result:**

- The oven is locked (no functions can be selected).
- The display shows “L”.



2. To unlock the oven, press the **Child Lock** button for 3 second.

**Result:** The oven can be used normally.

## Using the turntable on/off features

The **Turntable On/Off** button enables you to use large dishes which fill the whole oven by stopping the turntable from rotating (only manual cooking mode).

**IMPORTANT**

The results will be less satisfactory in this case as the cooking is less even. We recommend that you turn the dish by hand halfway through the cooking process.

**WARNING**

Never operate the turntable without food in the oven.

**Reason:** This may cause fire or damage to the unit.

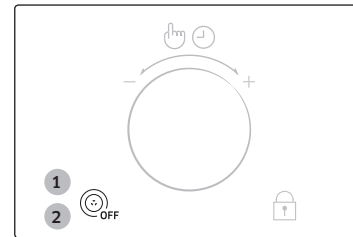

1. Press the **Turntable On/Off** button during setting Microwave, Grill, Hot Blast, Preheat and Combi function.
  - It is not available with pre-programmed function or before press the **Microwave, Grill, Hot Blast, Preheat** and **Combi** button.

**Result:** **Turntable On/Off** symbol appears on the display, the turntable will not rotate during the cooking.

 (Turntable off mode)

2. To switch the turntable rotating back on, press the **Turntable On/Off** button again.

**Result:** **Turntable On/Off** symbol disappears on the display, the turntable will rotate.

**NOTE**

This **Turntable On/Off** button is available only during cooking.

# Cookware guide

To cook food in the microwave oven, the microwaves must be able to penetrate the food, without being reflected or absorbed by the dish used.

Care must therefore be taken when choosing the cookware. If the cookware is marked microwave-safe, you do not need to worry.

The following table lists various types of cookware and indicates whether and how they should be used in a microwave oven.

Cookware	Microwave-safe	Comments
Aluminum foil	✓X	Can be used in small quantities to protect areas against overcooking. Arcing can occur if the foil is too close to the oven wall or if too much foil is used.
Crust plate	✓	Do not preheat for more than 8 minutes.
China and earthenware	✓	Porcelain, pottery, glazed earthenware and bone china are usually suitable, unless decorated with a metal trim.
Disposable polyester cardboard dishes	✓	Some frozen foods are packaged in these dishes.
Fast-food packaging		
• Polystyrene cups containers	✓	Can be used to warm food. Overheating may cause the polystyrene to melt.
• Paper bags or newspaper	X	May catch fire.
• Recycled paper or metal trims	X	May cause arcing.
Glassware		
• Oven-to-tableware	✓	Can be used, unless decorated with a metal trim.
• Fine glassware	✓	Can be used to warm foods or liquids. Delicate glass may break or crack if heated suddenly.
• Glass jars	✓	Must remove the lid. Suitable for warming only.

Cookware	Microwave-safe	Comments
Metal		
• Dishes	X	May cause arcing or fire.
• Freezer bag twist ties	X	
Paper		
• Plates, cups, napkins and kitchen paper	✓	For short cooking times and warming. Also to absorb excess moisture.
• Recycled paper	X	May cause arcing.
Plastic		
• Containers	✓	Particularly if heat-resistant thermoplastic. Some other plastics may warp or discolour at high temperatures. Do not use Melamine plastic.
• Cling film	✓	Can be used to retain moisture. Should not touch the food. Take care when removing the film as hot steam will escape.
• Freezer bags	✓X	Only if boilable or oven-proof. Should not be airtight. Prick with a fork, if necessary.
Wax or grease-proof paper	✓	Can be used to retain moisture and prevent spattering.

✓ : Recommended      ✓X : Use caution      X : Unsafe

# Cooking guide

## Microwaves

Microwave energy actually penetrates food, attracted and absorbed by its water, fat and sugar content.

The microwaves cause the molecules in the food to move rapidly. The rapid movement of these molecules creates friction and the resulting heat cooks the food.

## Cooking

### Cookware for microwave cooking:

Cookware must allow microwave energy to pass through it for maximum efficiency. Microwaves are reflected by metal, such as stainless steel, aluminium and copper, but they can penetrate through ceramic, glass, porcelain and plastic as well as paper and wood. So food must never be cooked in metal containers.

### Food suitable for microwave cooking:

Many kinds of food are suitable for microwave cooking, including fresh or frozen vegetables, fruit, pasta, rice, grains, beans, fish, and meat. Sauces, custard, soups, steamed puddings, preserves, and chutneys can also be cooked in a microwave oven. Generally speaking, microwave cooking is ideal for any food that would normally be prepared on a hob. Melting butter or chocolate, for example (see the chapter with tips, techniques and hints).

### Covering during cooking

To cover the food during cooking is very important, as the evaporated water rises as steam and contributes to cooking process. Food can be covered in different ways: e.g. with a ceramic plate, plastic cover or microwave suitable cling film.

### Standing times

After cooking is over food the standing time is important to allow the temperature to even out within the food.

## Cooking Guide for frozen vegetables

Use a suitable glass pyrex bowl with lid. Cook covered for the minimum time - see table. Continue cooking to get the result you prefer.

Stir twice during cooking and once after cooking. Add salt, herbs or butter after cooking. Cover during standing time.

Food	Serving size	Power	Time (min.)
Spinach	150 g	600 W	5-6
	<b>Instructions</b> Add 15 ml (1 tbsp) cold water. Serve after 2-3 minutes standing.		
Broccoli	300 g	600 W	8-9
	<b>Instructions</b> Add 30 ml (2 tbsp) cold water. Serve after 2-3 minutes standing.		
Peas	300 g	600 W	7-8
	<b>Instructions</b> Add 15 ml (1 tbsp) cold water. Serve after 2-3 minutes standing.		
Green Beans	300 g	600 W	7½-8½
	<b>Instructions</b> Add 30 ml (2 tbsp) cold water. Serve after 2-3 minutes standing.		
Mixed Vegetables (Carrots/Peas/ Corn)	300 g	600 W	7-8
	<b>Instructions</b> Add 15 ml (1 tbsp) cold water. Serve after 2-3 minutes standing.		
Mixed Vegetables (Chinese Style)	300 g	600 W	7½-8½
	<b>Instructions</b> Add 15 ml (1 tbsp) cold water. Serve after 2-3 minutes standing.		

# Cooking guide

## Cooking guide for fresh vegetables

Use a suitable glass pyrex bowl with lid. Add 30-45 ml cold water (2-3 tbsp) for every 250 g unless another water quantity is recommended – see table. Cook covered for the minimum time – see table. Continue cooking to get the result you prefer. Stir once during and once after cooking. Add salt, herbs or butter after cooking. Cover during a standing time of 3 minutes.

**Hint:** Cut the fresh vegetables into even sized pieces. The smaller they are cut, the quicker they will cook.

Food	Serving size	Power	Time (min.)
Broccoli	250 g	900 W	4-4½
	500 g		6-7
<b>Instructions</b> Prepare even sized florets. Arrange the stems to the centre. Serve after 3 minutes standing.			
Brussels Sprouts	250 g	900 W	5½-6
	<b>Instructions</b> Add 60-75 ml (5-6 tbsp) water. Serve after 3 minutes standing.		
Carrots	250 g	900 W	4-4½
	<b>Instructions</b> Cut carrots into even sized slices. Serve after 3 minutes standing.		
Cauliflower	250 g	900 W	4-4½
	500 g		6½-7½
<b>Instructions</b> Prepare even sized florets. Cut big florets into halves. Arrange stems to the centre. Serve after 3 minutes standing.			

Food	Serving size	Power	Time (min.)
Courgettes	250 g	900 W	3½-4
	<b>Instructions</b> Cut courgettes into slices. Add 30 ml (2 tbsp) water or a knob of butter. Cook until just tender. Serve after 3 minutes standing.		
Egg Plants	250 g	900 W	3-3½
	<b>Instructions</b> Cut egg plants into small slices and sprinkle with 1 tbsp lemon juice. Serve after 3 minutes standing.		
Leeks	250 g	900 W	3½-4
	<b>Instructions</b> Cut leeks into thick slices. Serve after 3 minutes standing.		
Mushrooms	125 g	900 W	1½-2
	250 g		2½-3
<b>Instructions</b> Prepare small whole or sliced mushrooms. Do not add any water. Sprinkle with lemon juice. Spice with salt and pepper. Drain before serving. Serve after 3 minutes standing.			
Onions	250 g	900 W	4-4½
	<b>Instructions</b> Cut onions into slices or halves. Add only 15 ml (1 tbsp) water. Serve after 3 minutes standing.		
Pepper	250 g	900 W	4½-5
	<b>Instructions</b> Cut pepper into small slices. Serve after 3 minutes standing.		
Potatoes	250 g	900 W	4-5
	500 g		7-8
<b>Instructions</b> Weigh the peeled potatoes and cut them into similar sized halves or quarters. Serve after 3 minutes standing.			

Food	Serving size	Power	Time (min.)
Turnip Cabbage	250 g	900 W	5½-6
	<b>Instructions</b> Cut turnip cabbage into small cubes. Serve after 3 minutes standing.		

### Cooking guide for rice and pasta

**Rice:** Use a large glass pyrex bowl with lid - rice doubles in volume during cooking. Cook covered. After the cooking time is over, stir before standing time and salt or add herbs and butter. Remark: the rice may not have absorbed all water after the cooking time is finished.

**Pasta:** Use a large glass pyrex bowl. Add boiling water, a pinch of salt and stir well. Cook uncovered. Stir occasionally during and after cooking. Cover during standing time and drain thoroughly afterwards.

Food	Serving size	Power	Time (min.)
White Rice (Parboiled)	250 g	450 W	15-16
	375 g		17½-18½
<b>Instructions</b>			
Add cold water of double quantity. Serve after 5 minutes standing.			
Brown Rice (Parboiled)	250 g	450 W	18-19
	375 g		20-21
<b>Instructions</b>			
Add cold water of double quantity. Serve after 5 minutes standing.			
Mixed Rice (Rice + Wild Rice)	250 g	450 W	18-19
	<b>Instructions</b>		
Add 500 ml cold water. Serve after 5 minutes standing.			
Mixed Corn (Rice + Grain)	250 g	450 W	20-21
	<b>Instructions</b>		
Add 400 ml cold water. Serve after 5 minutes standing.			

Food	Serving size	Power	Time (min.)
Pasta	250 g	900 W	9½-11
	<b>Instructions</b>		
Add 1000 ml hot water. Serve after 5 minutes standing.			
Instant Noodle	1 Small pack (80 g)	900 W	7-7½
	1 Big pack (120 g)		9-9½
<b>Instructions</b>			
Use a glass pyrex bowl. Put the noodle and add room temperature 350 ml water in bowl. Cook covered with wrap and pierce at several times. After cooking, drain water and mix instant noodle spices.			
Homemade Pizza	300-400g	HotBlast 190 °C	14½-15
	<b>Instructions</b>		
Pizza dough: 90g warm water, 3.5 g sachet dry yeast, ½ teaspoon caster sugar, ¼ teaspoon salt, 1 cups plain flour, 1 tablespoons olive oil. Pizza sauce: ½ tin chopped tomato, ½ tablespoons olive oil, ½ tablespoon salt, ½ garlic clove crushed, ¼ tsp dried oregano. Topping: 50 g Mozzarella cheese, grated 50g pizza sauce, 5 basil leaves. Put yeast, sugar, salt, warm water in a glass cup and mix them. Keep it in warm place for 5 minutes. Put flour, oil, mixture in a bowl and mix to a wettish dough. Knead in a mixer or by hand about 10 mins. Cover with lid and keep in warm place for 30 minutes. During fermentation, make a pizza sauce by mixing all ingredients. After fermentation, roll out into crusty plate. Spread a pizza sauce and add a topping on the dough. Preheat oven for 190 °C by using Hot Blast mode. After preheating, put them on the low rack. After cooking, stand for 2-3 minutes.			

# Cooking guide

---

## Reheating

Your microwave oven will reheat food in a fraction of the time that conventional ovens normally take.

Use the power levels and reheating times in the following chart as a guide. The times in the chart consider liquids with a room temperature of about +18 to +20 °C or a chilled food with a temperature of about +5 to +7 °C.

## Arranging and covering

Avoid reheating large items such as joint of meat - they tend to overcook and dry out before the centre is piping hot. Reheating small pieces will be more successful.

## Power levels and stirring

Some foods can be reheated using 900 W power while others should be reheated using 600 W, 450 W or even 300 W.

Check the tables for guidance.

In general, it is better to reheat food using a lower power level, if the food is delicate, in large quantities, or if it is likely to heat up very quickly (mince pies, for example).

Stir well or turn food over during reheating for best results. When possible, stir again before serving.

Take particular care when heating liquids and baby foods. To prevent eruptive boiling of liquids and possible scalding, stir before, during and after heating. Keep them in the microwave oven during standing time. We recommend putting a plastic spoon or glass stick into the liquids. Avoid overheating (and therefore spoiling) the food. It is preferable to underestimate cooking time and add extra heating time, if necessary.

## Heating and standing times

When reheating food for the first time, it is helpful to make a note of the time taken - for future reference.

Always make sure that the reheated food is piping hot throughout.

Allow food to stand for a short time after reheating - to let the temperature even out.

The recommended standing time after reheating is 2-4 minutes, unless another time is recommended in the chart.

Take particular care when heating liquids and baby food. See also the chapter with the safety precautions.

## Reheating liquids

Always allow a standing time of at least 20 seconds after the oven has been switched off to allow the temperature to even out. Stir during heating, if necessary, and ALWAYS stir after heating. To prevent eruptive boiling and possible scalding, you should put a spoon or glass stick into the beverages and stir before, during and after heating.

## Reheating baby food

### Baby food:

Empty into a deep ceramic plate. Cover with plastic lid. Stir well after reheating! Let stand for 2-3 minutes before serving. Stir again and check the temperature. Recommended serving temperature: between 30-40 °C.

### Baby milk:

Pour milk into a sterilised glass bottle. Reheat uncovered. Never heat a baby's bottle with teat on, as the bottle may explode if overheated. Shake well before standing time and again before serving ! Always carefully check the temperature of baby milk or food before giving it to the baby. Recommended serving temperature: ca. 37 °C.

## Remark:

Baby food particularly needs to be checked carefully before serving to prevent burns. Use the power levels and times in the next table as a guide lines for reheating.

## Reheating liquids and food

Use the power levels and times in this table as a guide lines for reheating.

Food	Serving size	Power	Time (min.)
Drinks (Coffee, Tea and Water)	150 ml (1 cup)	900 W	1-1½
	300 ml (2 cups)		2-2½
	450 ml (3 cups)		3-3½
	600 ml (4 cups)		3½-4
	<b>Instructions</b> Pour into cups and reheat uncovered: 1 cup in the centre, 2 cups opposite of each other, 3 cups in a circle. Keep in microwave oven during standing time and stir well. Serve after 1-2 minutes standing.		
Soup (Chilled)	250 g	600 W	4-4½
	350 g		5½-6
	450 g		6½-7
	550 g		8-8½
	<b>Instructions</b> Pour into a deep ceramic plate or deep ceramic bowl. Cover with plastic lid. Stir well after reheating. Stir again before serving. Serve after 2-3 minutes standing.		
Stew (Chilled)	350 g	600 W	4½-5½
	<b>Instructions</b> Put stew in a deep ceramic plate. Cover with plastic lid. Stir occasionally during reheating and again before standing and serving. Serve after 2-3 minutes standing.		

Food	Serving size	Power	Time (min.)
Pasta with Sauce (Chilled)	350 g	600 W	3½-4½
	<b>Instructions</b> Put pasta (e.g. spaghetti or egg noodles) on a flat ceramic plate. Cover with microwave cling film. Stir before serving. Serve after 3 minutes standing.		
Filled Pasta with Sauce (Chilled)	350 g	600 W	4-5
	<b>Instructions</b> Put filled pasta (e.g. ravioli, tortellini) in a deep ceramic plate. Cover with plastic lid. Stir occasionally during reheating and again before standing and serving. Serve after 3 minutes standing.		
Plated Meal (Chilled)	350 g	600 W	5-6
	450 g		6-7
	550 g		7-8
<b>Instructions</b> Plate a meal of 2-3 chilled components on a ceramic dish. Cover with microwave cling-film. Serve after 3 minutes standing.			
Cheese Fondue Ready-to-Serve (Chilled)	400 g	600 W	6-7
	<b>Instructions</b> Put the ready-to-serve cheese fondue in a suitable sized glass pyrex bowl with lid. Stir occasionally during and after reheating. Stir well before serving. Serve after 1-2 minutes standing.		

# Cooking guide

## Reheating baby food and milk

Use the power levels and times in this table as guide lines for reheating.

Food	Serving size	Power	Time
Baby Food (Vegetables + Meat)	190 g	600 W	30 sec.
	<b>Instructions</b> Empty into ceramic deep plate. Cook covered. Stir after cooking time. Before serving, stir well and check the temperature carefully. Serve after 2-3 minutes standing.		
Baby Porridge (Grain + Milk + Fruit)	190 g	600 W	20 sec.
	<b>Instructions</b> Empty into ceramic deep plate. Cook covered. Stir after cooking time. Before serving, stir well and check the temperature carefully. Serve after 2-3 minutes standing.		
Baby Milk	100 ml	300 W	30-40 sec.
	200 ml		1 min. to 1 min. 10 sec.
	<b>Instructions</b> Stir or shake well and pour into a sterilized glass bottle. Place into the centre of turntable. Cook uncovered. Before serving, shake well and check the temperature carefully. Serve after 2-3 minutes standing.		

## Defrosting

Microwaves are an excellent way of defrosting frozen food. Microwaves gently defrost frozen food in a short period of time. This can be of great advantage, if unexpected guests suddenly show up.

Frozen poultry must be thoroughly thawed before cooking. Remove any metal ties and take it out of any wrapping to allow thawed liquid to drain away.

Put the frozen food on a dish without cover. Turn over half way, drain off any liquid and remove any giblets as soon as possible. Check the food occasionally to make sure that it does not feel warm.

If smaller and thinner parts of the frozen food start to warm up, they can be shield by wrapping very small strips of aluminium foil around them during defrosting.

Should poultry start to warm up on the outer surface, stop thawing and allow it to stand for 20 minutes before continuing.

Leave the fish, meat and poultry to stand in order to complete defrosting. The standing time for complete defrosting will vary depending on the quantity defrosted. Please refer to the table below.

**Hint:** Flat food defrosts better than thick and smaller quantities need less time than bigger ones. Remember this hint while freezing and defrosting food.

For defrosting of frozen food with a temperature of about -18 to -20 °C, use the following table as a guide.

Food	Serving size	Power	Time (min.)
Meat	250 g	180 W	6-7
	500 g		8-13
Pork Steaks	250 g	180 W	7-8
	<b>Instructions</b> Place the meat on turntable. Shield thinner edges with aluminium foil. Turn over after half of defrosting time! Serve after 15-30 minutes standing.		

Food	Serving size	Power	Time (min.)
<b>Poultry</b>			
Chicken Pieces	500 g (2 pcs)	180 W	14-15
Whole Chicken	1200 g	180 W	32-34
<b>Instructions</b> First, put chicken pieces first skin-side down, whole chicken first breast-side-down on a flat ceramic plate. Shield the thinner parts like wings and ends with aluminium foil. Turn over after half of defrosting time! Serve after 15-60 minutes standing.			
<b>Fish</b>			
Fish Fillets	200 g	180 W	6-7
Whole Fish	400 g	180 W	11-13
<b>Instructions</b> Put frozen fish in the middle of a flat ceramic plate. Arrange the thinner parts under the thicker parts. Shield narrow ends of fillets and tail of whole fish with aluminium foil. Turn over after half of defrosting time! Serve after 10-25 minutes standing.			
<b>Fruits</b>			
Berries	300 g	180 W	6-7
<b>Instructions</b> Spread fruit on a flat, round glass dish (with a large diameter). Serve after 5-10 minutes standing.			

Food	Serving size	Power	Time (min.)
<b>Bread</b>			
Bread Rolls	2 pcs	180 W	1-1½
(each ca. 50 g)	4 pcs		2½-3
Toast/Sandwich	250 g	180 W	4-4½
German bread (Wheat + Rye Flour)	500 g	180 W	7-9
<b>Instructions</b> Arrange rolls in a circle or bread horizontally on kitchen paper in the middle of turntable. Turn over after half of defrosting time! Serve after 5-20 minutes standing.			

## Grill

The grill-heating element is located underneath the ceiling of the cavity. It operates while the door is closed and the turntable is rotating. The turntable's rotation makes the food brown more evenly. Preheating the grill for 3-5 minutes will make the food brown more quickly.

### Cookware for grilling:

Should be flameproof and may include metal. Do not use any type of plastic cookware, as it can melt.

### Food suitable for grilling:

Chops, sausages, steaks, hamburgers, bacon and gammon rashers, thin fish portions, sandwiches and all kinds of toast with toppings.

### Important remark:

Whenever the grill only mode is used, please remember that food must be placed on the high rack, unless another instruction is recommended.

# Cooking guide

## Microwave + Grill

This cooking mode combines the radiant heat that is coming from the grill with the speed of microwave cooking. It operates only while the door is closed and the turntable is rotating. Due to the rotation of the turntable, the food browns evenly. Three combination modes are available with this model: 600 W + Grill, 450 W + Grill and 300 W + Grill.

### Cookware for cooking with microwave + grill

Please use cookware that microwaves can pass through. Cookware should be flameproof. Do not use metal cookware with combination mode. Do not use any type of plastic cookware, as it can melt.

### Food suitable for microwave + grill cooking:

Food suitable for combination mode cooking include all kinds of cooked food which need reheating and browning (e.g. baked pasta), as well as foods which require a short cooking time to brown the top of the food. Also, this mode can be used for thick food portions that benefit from a browned and crispy top (e.g. chicken pieces, turning them over half way through cooking). Please refer to the grill table for further details.

### Important remark:

Whenever the combination mode (microwave + grill) is used, the food should be placed on the high rack, unless another instruction is recommended. Please refer to the instructions in the following chart. The food must be turned over, if it is to be browned on both sides.

## Grill guide for fresh food

Preheat the grill with the grill-function for 2-3 minutes. Use the power levels and times in this table as guide lines for grilling. Use oven gloves when taking out.

Fresh food	Serving size	Power	1 step (min.)	2 step (min.)
Toast Slices	4 pcs (each 25 g)	Grill only	3½-4	3-4
	<b>Instructions</b> Put toast slices side by side on the high rack.			
Grilled Tomatoes	400 g (2 pcs)	1 step: 450 W + Grill 2 step: Grill	4-6	1-2
	<b>Instructions</b> Cut tomatoes into halves. Put some cheese on top. Arrange in a circle in a flat glass pyrex dish. Place it on the high rack. Stand for 2-3 minutes.			
Tomato-Cheese Toast	4 pcs (300 g)	1 step: 300 W + Grill 2 step: Grill	5-7	1-2
	<b>Instructions</b> Toast the bread slices first. Put the toast with topping on the high rack. Stand for 2-3 minutes.			
Toast Hawaii (Ham, Pineapple, Cheese slices)	4 pcs (500 g)	1 step: 300 W + Grill 2 step: Grill	5-7	1-2
	<b>Instructions</b> Toast the bread slices first. Put the toast with topping on the high rack. Stand for 2-3 minutes.			
Baked Potatoes	500 g	1 step: 450 W + Grill 2 step: Grill	16-17	2-3
	<b>Instructions</b> Cut potatoes into halves. Put them in a circle on the high rack with the cut side to the grill.			

Fresh food	Serving size	Power	1 step (min.)	2 step (min.)
Gratin Potatoes/ Vegetables (Chilled)	450 g	1 step: 450 W + Grill 2 step: Grill	11-13	1-2
	<b>Instructions</b> Put the fresh gratin into a small glass pyrex dish. Put the dish on the high rack. After cooking stand for 2-3 minutes.			
Baked Apples	2 apples (ca. 400 g)	1 step: 300 W + Grill 2 step: Grill	7-8	1-2
	<b>Instructions</b> Core the apples and fill them with raisins and jam. Put some almond slices on top. Put apples on a flat glass pyrex dish. Place the dish directly on the low rack.			
Chicken Pieces	500 g (2 pcs)	1 step: 300 W + Grill 2 step: 300 W + Grill	10-12	12-14
	<b>Instructions</b> Brush chicken pieces with oil and spices. Put them in a circle on the high rack. After grilling stand for 2-3 minutes.			
Roast Chicken	1200 g	1 step: 450 W + HotBlast 200 °C 2 step: 300 W + Grill	21-23	31-33
	<b>Instructions</b> Brush the chicken oil and spices. Put the chicken on the low rack. After grilling stand for 5 minutes.			
Roast Fish	400-500 g	300 W + Grill	6-8	8-10
	<b>Instructions</b> Brush skin of whole fish with oil and add herbs and spices. Put two fishes side by side (head to tail) on the high rack. After grilling stand for 2-3 minutes.			

Fresh food	Serving size	Power	1 step (min.)	2 step (min.)
Roast Vegetables	300 g	Grill	9-11	-
	Rinse and prepare vegetables in slices (e.g. courgette, egg plants, pepper, pumpkin). Brush with olive oil and add spices. Put on crusty plate on high rack			
Plantain	1 ea (200 g)	1 step 450 W + Grill 2 step Grill	6-7	5-6
	<b>Instructions</b> peel and slice plantain 1 cm thick and put on the crusty plate with grill rack. Brush all sides with oil. If plantain becomes soft, reduce time 1-2 minute soft type. Stand for 1-2 minutes.			
Yam	200 g	1 step: 450 W + Grill 2 step: Grill	10-11	1-2
	<b>Instructions</b> Peel yam and cut into sticks with a thickness of 10 x 30 mm. Length is about 10 cm. Put on the crusty plate and brush all sides with oil. Put on the high rack and cook. Stand for 1-2 minutes.			

## Hot blast

Cooking with Hot blast is powerful combination of the grill heater and the convection heater with fan. The hot air blows from the top of the cavity through holes into the oven. The heating element at top and back side and the fan at the back side-wall, keeps the hot air circulating evenly.

### Cookware for Hot blast cooking

All conventional ovenproof cookware, baking tins and sheets - anything you would normally use in a traditional convection oven - can be used.

### Food suitable for Hot blast cooking

Use this mode for biscuits, individual scones, rolls, and cakes as well as fruits cakes, choux, and souffles.

# Cooking guide

## Microwave + Hot blast

This mode combines the microwave energy with the hot air and is therefore reducing the cooking time while giving the food a brown and crispy surface. Cooking with convection is the traditional and well known method of cooking food in an oven with hot air circulated by a fan on the back-wall.

### Cookware for cooking with microwaves + Hot blast

Should be able to let the microwaves pass through. Should be ovenproof (like glass, pottery or china without metal trims); similar to the cookware described under Microwave + Grill.

### Food suitable for microwave + Hot blast cooking:

All kinds of meats and poultry as well as casseroles and gratin dishes, sponge cakes and light fruit cakes, pies and crumbles, roast vegetables, scones and breads.

### Hot blast guide for fresh and frozen food

Preheat the Hot blast with the Hot blast function to the desired temperature. Use the power levels and times in this table as guide lines for Hot blast cooking. Use oven gloves when taking out.

Food	Serving size (g)	Mode (°C)	Cooking Time (min.)
Frozen mini tartes/ pizza snacks	250	200	9-11
	Put pizza snacks on the crusty plate. Put plate on low rack.		
Frozen Oven Chips	300	200	22-25
	Distribute frozen oven chips on crusty plate. Put plate on high rack.		
Frozen chicken nuggets	300	200	8-11
	Put frozen nuggets on crusty plate. Put plate on the high rack.		
Frozen Pizza	300-400	200	11-14
	Put frozen Pizza on the low rack.		

Food	Serving size (g)	Mode (°C)	Cooking Time (min.)
Homemade Lasagna/ Pasta Gratin	500	170	15-20
	Put pasta in ovenproof dish. Put dish on low rack.		
Frozen lasagne	400	450 W + 180 °C	16-18
	Put into a suitable sized glass pyrex dish or leave in the original packaging (take care that this is suitable for microwaves and oven heat). Put frozen lasagne on the low rack. After cooking stand for 2-3 minutes.		
Roast beef/Lamb (medium)	1000-1200	450 W + 160 °C	20-22 (first side) 15-17 (second side)
	Brush beef/ lamb with oil and spice it with pepper, salt and paprika. Put it on the low rack, first with the fat side down. After cooking wrap in aluminium foil and stand for 10-15 minutes.		
Frozen bread rolls	350 (6 pcs)	180 W + 160 °C	8-10
	Put bread rolls on crusty plate. Put plate on the low rack. Stand 2-3 minutes.		
Marble cake	700	160	50-55
	Put the fresh dough in a small rectangular black metal baking dish (length 25 cm). Put the dish on the low rack. After baking stand for 5-10 minutes.		
Small Cakes	each 30	160	30-35
	Put up to 12 small cakes / muffins in paper cups on crusty plate. Put plate on low rack. After baking stand for 5 minutes.		
Croissants/Bread rolls (fresh dough)	200-250	200	13-18
	Put the chilled croissants or bread rolls on baking paper on the low rack.		

Food	Serving size (g)	Mode (°C)	Cooking Time (min.)
Frozen cake	1000	180 W + 160 °C	18-20
	Put the frozen cake directly on the low rack. After defrost and warming keep standing for 15-20 minutes.		
Homemade Potato Gratin	500	450 W + 180 °C	20-23
	Put Gratin in ovenproof dish. Set on low rack.		
Homemade Quiche (Medium size)	500-600	160	45-50
	Prepare quiche using metal medium size pan and put on low rack. Refer a recipe in Hot Blast auto cook guide.		

## Tips and tricks

### Melting butter

Put 50 g butter into a small deep glass dish. Cover with plastic lid. Heat for 30-40 seconds using 900 W, until butter is melted.

### Melting chocolate

Put 100 g chocolate into a small deep glass dish. Heat for 3-5 minutes, using 450 W until chocolate is melted. Stir once or twice during melting. Use oven gloves while taking out!

### Melting crystallized honey

Put 20 g crystallized honey into a small deep glass dish. Heat for 20-30 seconds using 300 W, until honey is melted.

### Melting gelatine

Lay dry gelatine sheets (10 g) for 5 minutes into cold water. Put drained gelatine into a small glass pyrex bowl. Heat for 1 minute using 300 W. Stir after melting.

### Cooking glaze/icing (for cake and gateaux)

Mix instant glaze (approximately 14 g) with 40 g sugar and 250 ml cold water. Cook uncovered in a glass pyrex bowl for 3½ to 4½ minutes using 900 W, until glaze/icing is transparent. Stir twice during cooking.

### Cooking jam

Put 600 g fruits (for example mixed berries) in a suitable sized glass pyrex bowl with lid. Add 300 g preserving sugar and stir well. Cook covered for 10-12 minutes using 900 W. Stir several times during cooking. Empty directly into small jam glasses with twist-off lids. Stand on lid for 5 minutes.

### Cooking pudding

Mix pudding powder with sugar and milk (500 ml) by following the manufacturers instructions and stir well. Use a suitable sized glass pyrex bowl with lid. Cook covered for 6½ to 7½ minutes using 900 W. Stir several times well during cooking.

### Browning almond slices

Spread 30 g sliced almonds evenly on a medium sized ceramic plate. Stir several times during browning for 3½ to 4½ minutes using 600 W. Let it stand for 2-3 minutes in the oven. Use oven gloves while taking out!

# Troubleshooting

## Troubleshooting

If you have any of the problems listed below try the solutions given.

Problem	Cause	Action
<b>General</b>		
The buttons cannot be pressed properly.	Foreign matter may be caught between the buttons.	Remove the foreign matter and try again.
	For touch models: Moisture is on the exterior.	Wipe the moisture from the exterior.
	Child lock is activated.	Deactivate Child lock.
The time is not displayed.	The Eco (power-saving) function is set.	Turn off the Eco function.
The oven does not work.	Power is not supplied.	Make sure power is supplied.
	The door is open.	Close the door and try again.
	The door open safety mechanisms are covered in foreign matter.	Remove the foreign matter and try again.
The oven stops while in operation.	The user has opened the door to turn food over.	After turning over the food, press the <b>Start</b> button again to start operation.

Problem	Cause	Action
The power turns off during operation.	The oven has been cooking for an extended period of time.	After cooking for an extended period of time, let the oven cool.
	The cooling fan is not working.	Listen for the sound of the cooling fan.
	Trying to operate the oven without food inside.	Put food in the oven.
	There is not sufficient ventilation space for the oven.	There are intake/exhaust outlets on the front and rear of the oven for ventilation. Keep the gaps specified in the product installation guide.
	Several power plugs are being used in the same socket.	Designate only one socket to be used for the oven.
There is a popping sound during operation, and the oven doesn't work.	Cooking sealed food or using a container with a lid may causes popping sounds.	Do not use sealed containers as they may burst during cooking due to expansion of the contents.
The oven exterior is too hot during operation.	There is not sufficient ventilation space for the oven.	There are intake/exhaust outlets on the front and rear of the oven for ventilation. Keep the gaps specified in the product installation guide.
	Objects are on top of the oven.	Remove all objects on the top of the oven.

Problem	Cause	Action
The door cannot be opened properly.	Food residue is stuck between the door and oven interior.	Clean the oven and then open the door.
Heating including the Warm function does not work properly.	The oven may not work, too much food is being cooked, or improper cookware is being used.	Put one cup of water in a microwave-safe container and run the microwave for 1-2 minutes to check whether the water is heated. Reduce the amount of food and start the function again. Use a cooking container with a flat bottom.
The thaw function does not work.	Too much food is being cooked.	Reduce the amount of food and start the function again.
The interior light is dim or does not turn on.	The door has been left open for a long time.	The interior light may automatically turn off when the Eco function operates. Close and reopen the door or press the <b>Cancel</b> button.
	The interior light is covered by foreign matter.	Clean the inside of the oven and check again.
A beeping sound occurs during cooking.	If the Auto Cook function is being used, this beeping sound means it's time to turn over the food during thawing.	After turning over the food, press the <b>Start</b> button again to restart operation.

Problem	Cause	Action
The oven is not level.	The oven is installed on an uneven surface.	Make sure the oven is installed on flat, stable surface.
There are sparks during cooking.	Metal containers are used during the oven/thawing functions.	Do not use metal containers.
When power is connected, the oven immediately starts to work.	The door is not properly closed.	Close the door and check again.
There is electricity coming from the oven.	The power or power socket is not properly grounded.	Make sure the power and power socket are properly grounded.
<ol style="list-style-type: none"> <li>1. Water drips.</li> <li>2. Steam emits through a door crack.</li> <li>3. Water remains in the oven.</li> </ol>	There may be water or steam in some cases depending on the food. This is not an oven malfunction.	Let the oven cool and then wipe with a dry dish towel.
The brightness inside the oven varies.	Brightness changes depending on power output changes according to function.	Power output changes during cooking are not malfunctions. This is not an oven malfunction.
Cooking is finished, but the cooling fan is still running.	To ventilate the oven, the cooling fan continues to run for about 3 minutes after cooking is complete.	This is not an oven malfunction.

# Troubleshooting

Problem	Cause	Action
<b>Turntable</b>		
While turning, the turntable comes out of place or stops turning.	There is no roller ring, or the roller ring is not properly in place.	Install the roller ring and then try again.
The turn table drags while turning.	The roller ring is not properly in place, there is too much food, or the container is too large and touches the inside of the microwave.	Adjust the amount of food and do not use containers that are too large.
The turn table rattles while turning and is noisy.	Food residue is stuck to the bottom of the oven.	Remove any food residue stuck to the bottom of the oven.
<b>Grill</b>		
Smoke comes out during operation.	During initial operation, smoke may come from the heating elements when you first use the oven.	This is not a malfunction, and if you run the oven 2-3 times, it should stop.
	Food is on the heating elements.	Let the oven cool and then remove the food from the heating elements.
	Food is too close to the grill.	Put the food a suitable distance away while cooking.
	Food is not properly prepared and/or arranged.	Make sure food is properly prepared and arranged.

Problem	Cause	Action
<b>Oven</b>		
The oven does not heat.	The door is open.	Close the door and try again.
Smoke comes out during preheating.	During initial operation, smoke may come from the heating elements when you first use the oven.	This is not a malfunction, and if you run the oven 2-3 times, it should stop.
	Food is on the heating elements.	Let the oven cool and then remove the food from the heating elements.
There is a burning or plastic smell when using the oven.	Plastic or non heat-resistant cookware is used.	Use glass cookware suitable for high temperatures.
There is a bad smell coming from inside the oven.	Food residue or plastic has melted and stuck to the interior.	Use the steam function and then wipe with a dry cloth. You can put a lemon slice inside and run the oven to remove the odour more quickly.

Problem	Cause	Action
The oven does not cook properly.	The oven door is frequently opened during cooking.	If you open the door often, the interior temperature will be lowered and this may affect the results of your cooking.
	The oven controls are not correctly set.	Correctly set the oven controls and try again.
	The grill or other accessories are not correctly inserted.	Correctly insert the accessories.
	The wrong type or size of cookware is used.	Use suitable cookware with flat bottoms.

 **NOTE**

If the above guidelines do not enable you to solve the problem, then contact your local SAMSUNG customer service centre.

Please have the following information read;

- The model and serial numbers, normally printed on the rear of the oven
- Your warranty details
- A clear description of the problem

Then contact your local dealer or SAMSUNG aftersales service.

## Information code

Check code	Cause	Action
C-20	Temperature sensor is needed to check.	Press the <b>Stop/Cancel</b> button and operate again. If it occurs again, turn off the microwave oven over 30 seconds and try setting again. If it appears again, call your local SAMSUNG Customer Care Centre.
C-21	Temperature sensor detect higher temperature than setting temperature.	Turn off the microwave oven for cooling the product and then try setting again. If it appears again, call your local SAMSUNG Customer Care Centre.
C-d0	Control buttons are pressed over 10 seconds.	Clean the keys and check if there is water on the surface around key. If it occurs again, turn off the microwave oven over 30 seconds and try setting again. If it appears again, call your local SAMSUNG Customer Care Centre.

 **NOTE**

For any codes not listed above, or if the suggested solution does not solve the problem, contact your local SAMSUNG Customer Care Centre.

# Technical specifications



SAMSUNG strives to improve its products at all times. Both the design specifications and these user instructions are thus subject to change without notice.

Please be advised that the Samsung warranty does NOT cover service calls to explain product operation, correct improper installation, or perform normal cleaning or maintenance.

### QUESTIONS OR COMMENTS?

Model	MC32K7058**
<b>Power source</b>	240 V ~ 50 Hz AC
<b>Power consumption</b>	
Maximum power	2300 W
Microwave	1400 W
Grill (heating element)	1650 W
Hot blast (heating element)	Max. 2300 W
<b>Output power</b>	100 W / 900 W - 6 levels (IEC-705)
<b>Operating frequency</b>	2450 MHz
<b>Dimensions (W x H x D)</b>	
Outside (Include Handle)	523 x 309 x 479.8 mm
Oven cavity	373 x 233 x 370 mm
<b>Volume</b>	32 liter
<b>Weight</b>	
Net	20.0 kg approx.

COUNTRY	CALL	OR VISIT US ONLINE AT
AUSTRALIA	1300 362 603	<a href="http://www.samsung.com/au/support">www.samsung.com/au/support</a>
NEW ZEALAND	0800 726 786	<a href="http://www.samsung.com/nz/support">www.samsung.com/nz/support</a>
CHINA	400-810-5858	<a href="http://www.samsung.com/cn/support">www.samsung.com/cn/support</a>
HONG KONG	3698 4698	" <a href="http://www.samsung.com/hk/support">www.samsung.com/hk/support</a> (Chinese) <a href="http://www.samsung.com/hk_en/support">www.samsung.com/hk_en/support</a> (English)"
INDIA	1800 3000 8282 - Toll Free 1800 266 8282 - Toll Free	<a href="http://www.samsung.com/in/support">www.samsung.com/in/support</a>
BANGLADESH	0961-2300300 0800-0300300 (Toll free)	
INDONESIA	021-56997777 8001128888	<a href="http://www.samsung.com/id/support">www.samsung.com/id/support</a>
JAPAN	0120-363-905	<a href="http://www.samsung.com/jp/support">www.samsung.com/jp/support</a>
MALAYSIA	1800-88-9999 603-77137477 (Overseas contact)	<a href="http://www.samsung.com/my/support">www.samsung.com/my/support</a>
PHILIPPINES	1-800-10-726-7864 [ PLDT Toll Free ] 1-800-8-726-7864 [ Globe Landline and Mobile ] 02- 422-2111 [ Standard Landline ]	<a href="http://www.samsung.com/ph/support">www.samsung.com/ph/support</a>
SINGAPORE	1800-SAMSUNG(726-7864)	<a href="http://www.samsung.com/sg/support">www.samsung.com/sg/support</a>
THAILAND	0-2689-3232 1800-29-3232	<a href="http://www.samsung.com/th/support">www.samsung.com/th/support</a>
TAIWAN	0800-329999	<a href="http://www.samsung.com/tw/support">www.samsung.com/tw/support</a>
VIETNAM	1800 588 889	<a href="http://www.samsung.com/vn/support">www.samsung.com/vn/support</a>
MACAU	0800 333	<a href="http://www.samsung.com/support">www.samsung.com/support</a>
MYANMAR	+95-1-2399-888	
SRI LANKA	117540540 115900000	

DE68-04387P-01