

OWNER'S MANUAL

**MODEL NO.
625.384600**

Caution:
Read and Follow
All Safety Rules,
Installation and
Operating
Instructions
Before First Use
of This Product.

If you have questions
when installing and us-
ing your drinking water
filter system, call this
toll-free number...

1 - 800 - 426 - 9345

SAVE THIS MANUAL

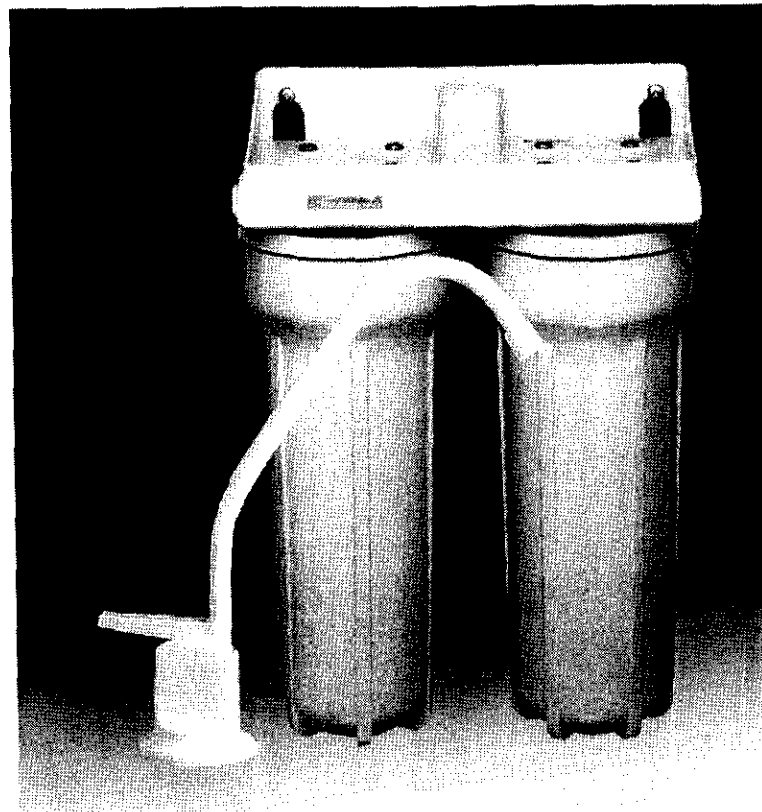

UNDERSINK DRINKING WATER FILTER SYSTEM

- ◆ Safety Guides
- ◆ Installation
- ◆ Operation
- ◆ Cartridge Replacement
- ◆ Repair Parts

System tested and certified by NSF International to
ANSI/NSF Standard 42 and 53 for the reduction of
the claims specified on the performance data sheet.

NSF.

Sears, Roebuck and Co., Hoffman Estates, IL 60179 USA

SAFETY GUIDES / SPECIFICATIONS

▼ Read all steps and guides carefully before installing and using your undersink drinking water filter system. Follow all steps exactly to correctly install. Reading this manual will also help you to get all the benefits from the undersink drinking water filter system.

▼ Do not use with water that is microbiologically unsafe or of unknown quality without adequate disinfection before or after the system. This system is certified for cyst reduction and may be used on disinfected waters that may contain filterable cysts.

▼ Check with your local public works department for plumbing and sanitation codes. You must follow their guides as you install the system. Follow your local codes if they differ with guides in this manual. In Massachusetts, plumbing codes of

Massachusetts shall be adhered to. Consult with your licensed plumber.

▼ The undersink drinking water filter system works on water pressures of 40 psi (minimum) to 100 psi (maximum). If your house water pressure is over the maximum, install a pressure reducing valve in the water supply pipe to the filter system.

▼ Do not install the undersink drinking water filter system outside, or in extreme hot or cold temperatures. Temperature of the water supply to the undersink drinking water filter system must be between 40°F and 100°F. Do not install on hot water.

▼ Read the other limits (pH, hardness, etc.) in the specifications and be sure your water supply conforms.

Min. - Max. Supply Water Pressure	40 - 100 psi
Min. - Max. Supply Water Temperature	40 - 100 °F
Inlet - Outlet	3/8" NPT, fittings and tubing included

WARRANTY

FULL ONE YEAR WARRANTY ON UNDERSINK DRINKING WATER FILTER SYSTEM

For one year from the date of purchase, Sears will replace this Undersink Drinking Water Filter System (except filter cartridges, which are purchased separately), free of charge, if defective in material or workmanship.

WARRANTY IS AVAILABLE BY SIMPLY RETURNING THE UNDERSINK DRINKING WATER FILTER SYSTEM TO THE NEAREST SEARS STORE THROUGHOUT THE UNITED STATES.

This warranty gives you specific legal rights, and you may have other rights which vary from state to state.

Sears, Roebuck and Co., DEPT. 817 WA, Hoffman Estates, IL 60179

TABLE OF CONTENTS

Parts of the System / Typical Installation Drawing / Tools and Materials Needed	4
Drinking Water Filter System Installation	5 - 7
Installing Supply Fitting	5
Installing Faucet	5 - 6
Installing Filter Cartridge	7
Using the Filtered Water System	8
Filter Cartridge Life / Replacement	8 - 9
Repair Parts	10 - 11

Locate the water filter housing on the **cold** water supply pipe, under the kitchen and/or bathroom sink, to filter the cold drinking water. Refer to the following drawing.

FILTERING WATER TO ONE FAUCET

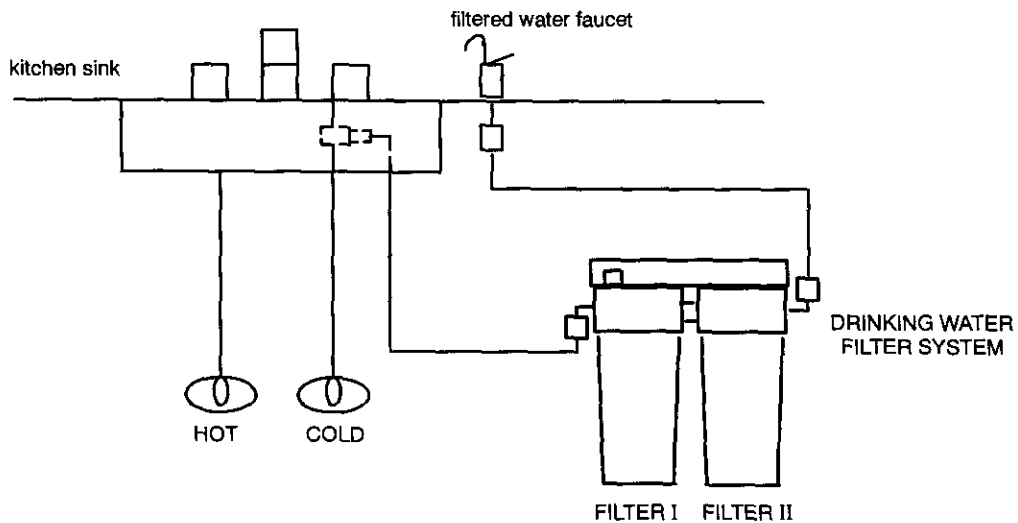

PARTS OF THE SYSTEM

- ✓ filter system assembly including mounting bracket and screws
- ✓ water supply fitting
- ✓ filtered water faucet for sink or countertop mounting
- ✓ 3/8" tubing to make all needed connections

MATERIALS AND TOOLS NEEDED

- plumbers putty
- slotted and Phillips screwdrivers
- pliers and adjustable jaw wrench
- tubing cutter
- sandpaper or emery cloth
- electric drill and 3/4" drill bit if mounting hole is needed for the faucet, see page 6

CAUTION: To avoid damaging the sink, consult a qualified plumber or installer for drilling procedures in porcelain or stainless steel.

TYPICAL UNDERSINK INSTALLATION

FIG. 1

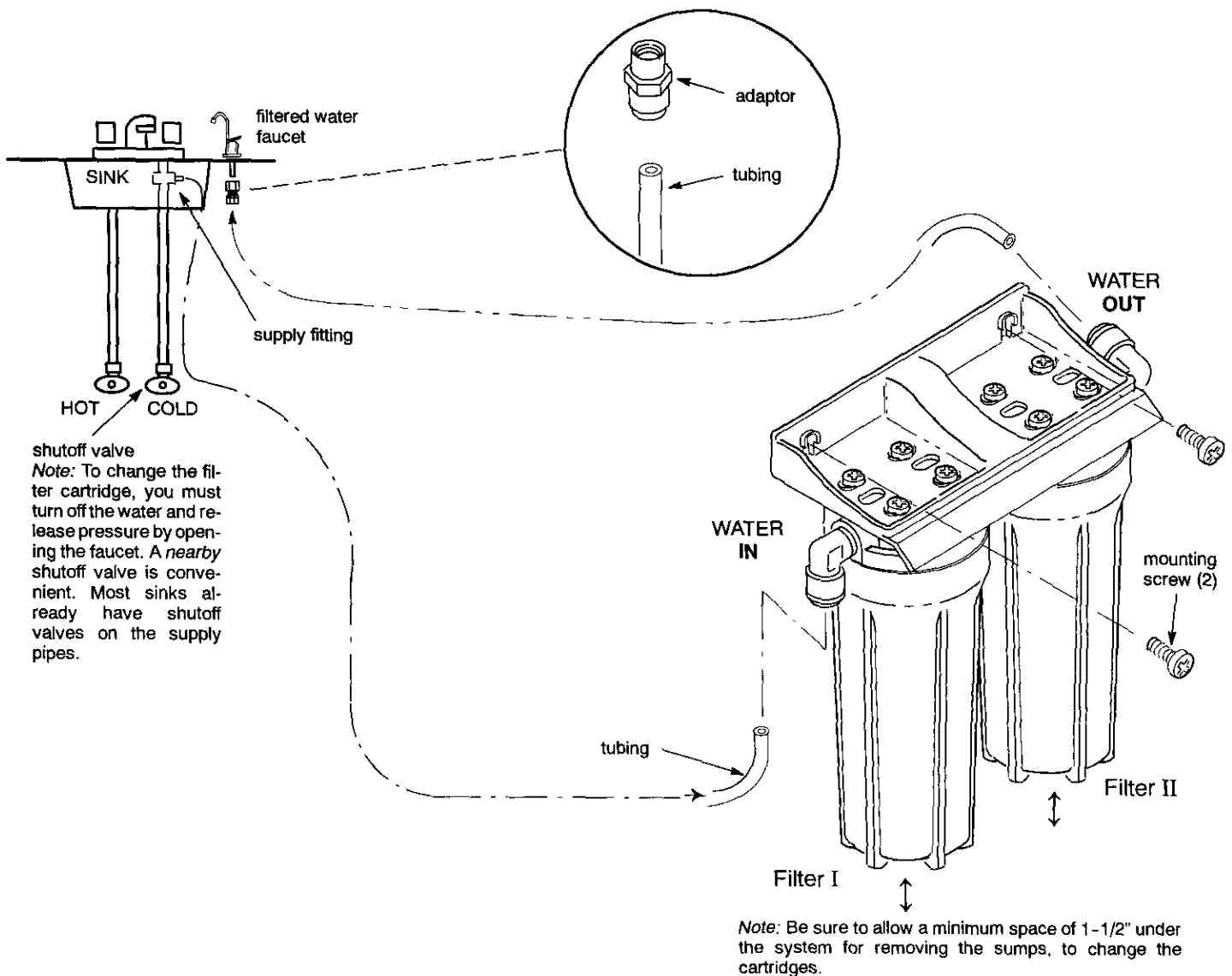

INSTALLATION STEPS

STEP 1 - COLD WATER SUPPLY FITTING

Check and comply with local plumbing codes as you plan, then install a cold feed (supply) water fitting. The fitting must provide a leak-tight connection to the water filter 3/8" tubing. A typical connection using the included water supply fitting is shown in FIG.2 - A. An optional connection using standard plumbing fittings (not included), is shown in B.

A. WATER SUPPLY FITTING

1. Close the house main water shutoff valve and open faucets to drain water from the sink cold water pipe.
2. Remove nut that connects the cold water faucet to cold water plumbing.
3. Thread water supply fitting onto pipe and reconnect nut to bottom of fitting.

B. OPTIONAL PIPE FITTINGS

(compression type shown)

Note: Be sure to turn off the water supply and open a low faucet to drain the pipe.

Complying with plumbing codes, install a fitting on the cold water pipe to adapt 3/8" OD tubing. A typical connection is shown in figure 2B. If threaded fittings are used, be sure to use pipe joint compound or Teflon tape on outside threads.

FIG. 2

A. WATER SUPPLY CONNECTION
(using included water supply fitting)

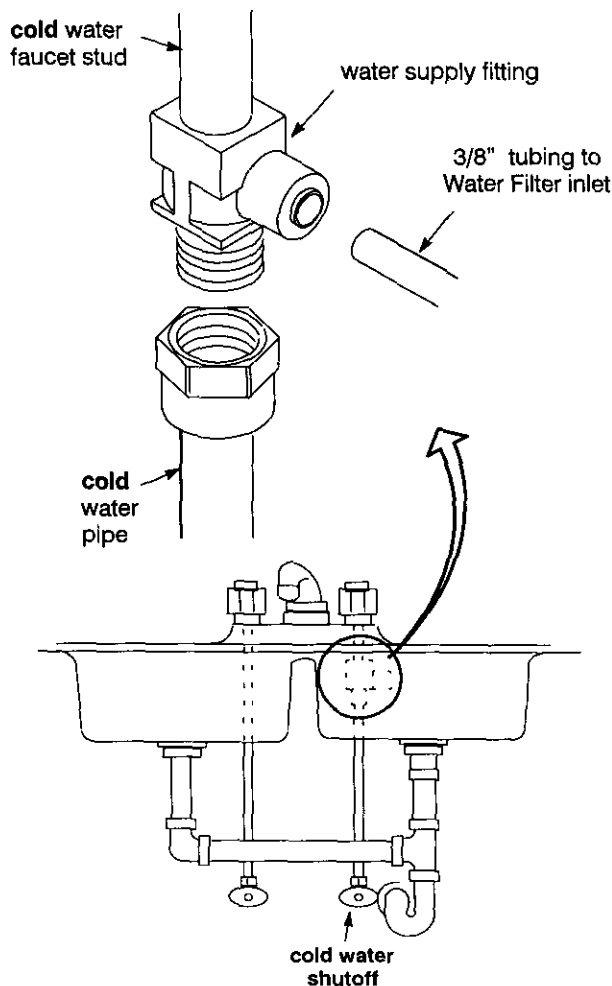

B. WATER SUPPLY TYPICAL CONNECTION
(using compression fitting)

- parts not included -

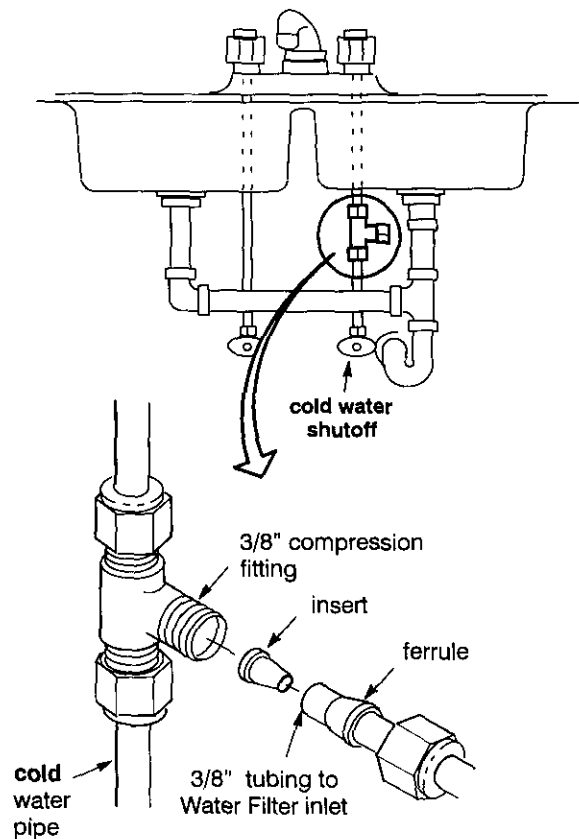

INSTALLATION STEPS

STEP 2 - MAKE HOLE FOR FILTERED WATER FAUCET

Select 1 of the following places to install the faucet. Be sure there's room underneath so you can make the needed connections.

- In an existing sink spray attachment hole.
- Drill a hole in the sink top.
- Drill a hole in the countertop next to the sink.

1. If drilling is needed make a 3/4" dia. (minimum) hole for the faucet.

CAUTION: To avoid damaging the sink, consult a qualified plumber or installer for drilling procedures

in porcelain or stainless steel. Special drill bits are made for this.

2. Place plumbers putty around the drilled hole to prevent water leaks around the faucet.

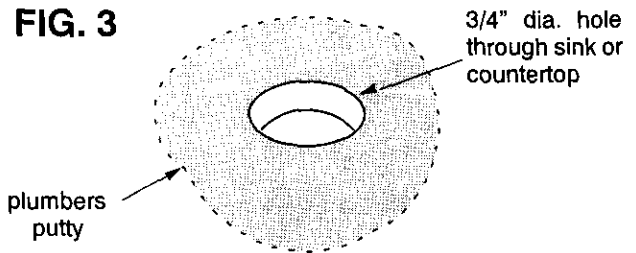

STEP 3 - ASSEMBLE AND INSTALL FAUCET

Note: If the faucet is not assembled, slide the lever over the cylindrical nut. Then push or turn the spout into the faucet body.

1. Faucet, FIG. 4:

A. If not already assembled, install the rubber washer, spacer, flat (or lock) washer and hex nut onto the threaded faucet stud.

B. Apply Teflon tape to the end of the faucet stud. Turn the tubing adapter onto the stud and hand tighten, then wrench 1/4 turn only. **BE CAREFUL NOT TO CROSS THREAD.**

3. Wet the o-ring seals on the faucet spout. Then, remove and discard the short piece of tubing from the faucet body and insert the spout in it's place.

4. Connect tubing to faucet as follows.

5. Lower the faucet into the sink or countertop hole.

6. On the underside of the sink or countertop insert the large steel washer between the mounting hole and the spacer on the faucet stud (see assembled view). Then turn the hex nut up to the spacer and tighten. **Tighten the hex nut so the faucet can not move, but do not overtighten and break the faucet.**

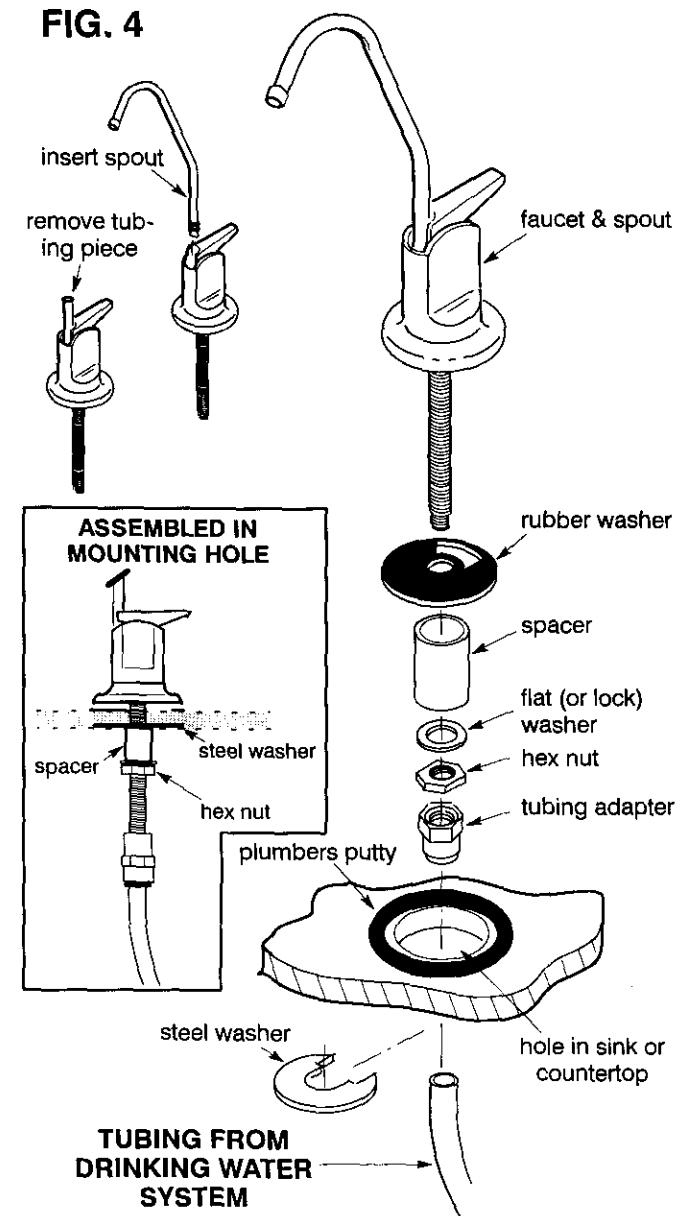

INSTALLATION STEPS

STEP 4 - MAKE TUBING CONNECTIONS

1. Allowing some slack, measure and cut a length of 3/8" tubing to connect between the supply fitting and the filter system inlet, FIG. 1. Cut the ends of the tubing square.
2. Insert tubing all the way into the supply fitting and inlet elbow fitting. **Pull on the tubing to be sure that it's held firmly in the fitting.**
3. Repeat steps 1 and 2 to connect tubing between the filter system outlet and the adaptor on the bottom of the faucet stud, FIG. 1.

TUBING CONNECTION (all push-in fitting locations)

This system includes push-in fittings for quick tubing connection at most locations. If working with the fittings do the following.

Connection, FIG. 5:

1. Use a sharp cutter or knife to cut the end of tubing square.
2. Inspect the end (about 1") of the tubing to be sure there are no nicks, scratches or other rough spots. If needed cut the tubing again.
3. Push tubing through the collet and all the way into fitting. Full engagement is 11/16" for 1/4" tubing, and 3/4" for 3/8" tubing.

If tubing other than supplied with the system is used, be sure it is of high quality, exact size and roundness with a smooth surface.

To Disconnect Tubing: Push the collet inward and hold with a finger while pulling the tubing out.

FIG. 5

Tubing correctly cut and connected

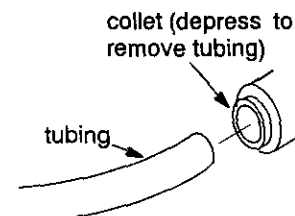
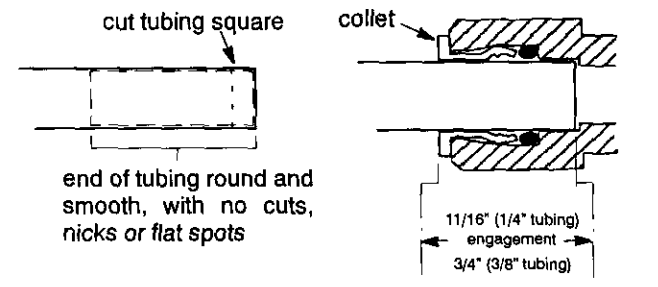

CAUTION

DO NOT USE VINEGAR, OR OTHER ACID BASED CLEANERS ON THIS SYSTEM. THEY WILL DEGRADE SOME SYSTEM PARTS. ALWAYS USE SOAP AND WATER.

STEP 5 - FILTER CARTRIDGE INSTALLATION

Turn to page 9 and follow all steps under "Filter Cartridge Replacement".

USING THE SYSTEM

The sink or countertop faucet vends the filtered water when opened. It has a hand operated, spring loaded closed lever to prevent waste. You can also keep the faucet open by pushing upward on the lever and locking it against the faucet spout.

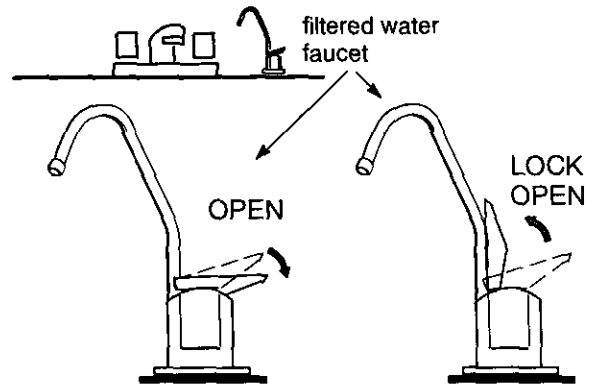

FILTER CARTRIDGE / USEFUL LIFE / REPLACEMENT

FILTER CARTRIDGE LIFE

Several variables determine how long a cartridge will last. These include:

1. how much water you use
2. how much sediment, taste and/or odor, or other unwanted substance, is in the water

Use the following information as a guide. However, no matter which type of cartridge you are using, you will know **it is time to replace it when you first notice the return of the unwanted substance in your water.**

Kenmore system model 625.384600 with replacement elements 42-34370 and 42-34377 has been tested and certified by NSF International for the reduction of protozoan cysts, lead and chlorine. The rated capacity for this system is 1000 gallons.

Other filter cartridges are available from Sears to remove sediments, tastes and odors, and chemical contaminants. Following is a list of filter cartridges available.

Taste and Odor Cartridges: Many bad tastes and/or odors are removed from water by an activated carbon cartridge. It is most often used to remove chlorine taste and smell, usually to a single faucet such as the kitchen cold.

Note: Small amounts of hydrogen sulfide (noticeable as "rotten egg" odor) may be reduced by taste and odor filters for a short time, quickly exhausting the carbon media. Consult your Sears store for proper continuous treatment.

Sears Item No. 42-34362: for sediment removal,
Sears Item No. 42-34365: for 99% chlorine reduction, *plus* chemical contaminants

Sediment Filter Cartridge, Sears Item No. 42-34360 (25 micron): Sediment cartridges remove sand, silt, clay, dirt, and other sediments from water. The 25 micron cartridge filters larger sediments from water, and allows higher flows at less pressure drop.

FILTER CARTRIDGE REPLACEMENT

CAUTION: Never remove sumps with water pressure in the filter system.

1. Close the water supply shut-off valve (FIG. 1, page 4) to the filter. Open the filtered water faucet to relieve pressure in the system.

2. Turn the sump off of the filter head, to the left or clockwise. Be careful, the sump is full of water. Do not lose the large o-ring seal.

Note: A special wrench is available from Sears for removing the sump. See the parts list on page 11.

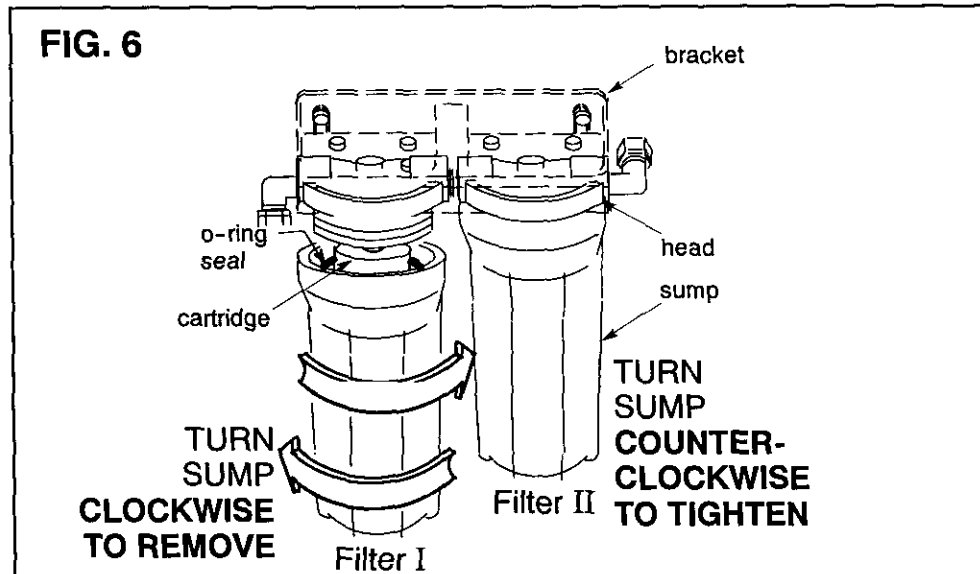

3. Be sure the inside of the sump is clean. Use hot, soapy water and rinse thoroughly.

4. Remove the wrapper from the new filter cartridge and insert the filter cartridge in the sump. Some cartridges fit either way, while others fit only one way. Observe markings on the cartridge, or on the wrapper.

Note: If you are installing two different types of filter cartridges, be sure to install in filters I and II as the guideline on page 3 shows.

5. Lightly lubricate the o-ring seal in the sump with silicone grease or Vaseline. Be sure it is fully seated in its groove.

6. Hold the sump up to the filter head aligning the center hole in the cartridge with the protrusion on the bottom of the head.

Note: If the sump will not tighten up to the head you may have the cartridge in upside down. Take the cartridge out and check for correct orientation.

7. Being careful not to cross-thread, turn (counter-clockwise) the sump onto the filter head and tighten securely.

8. Repeat steps 2 through 7 at the other filter.

9. Open the filtered water faucet. Then, slowly open the water supply valve and allow the filter housing to fill.

10. Close the filtered water faucet. Check for leaks between the sump and the head.

Note: If leaking, turn off the water supply and open the filtered water faucet to depressurize the filter. Then disassemble the filter and check the o-ring for cuts, flat spots, etc., and sealing surfaces for foreign material. Clean the o-ring and lubricate with silicone grease or Vaseline. Carefully press into the groove in the sump.

11. Taste and Odor Cartridges: A taste and odor cartridge contains activated carbon, a black powder. When new, open the filtered water faucet and allow fine, harmless carbon particles to purge from the cartridge. Close the faucet when you no longer see the "fines" in the filtered water, or approximately 10 minutes.

REPAIR PARTS

Kenmore Undersink Drinking Water Filter System, Model No. 625.384600

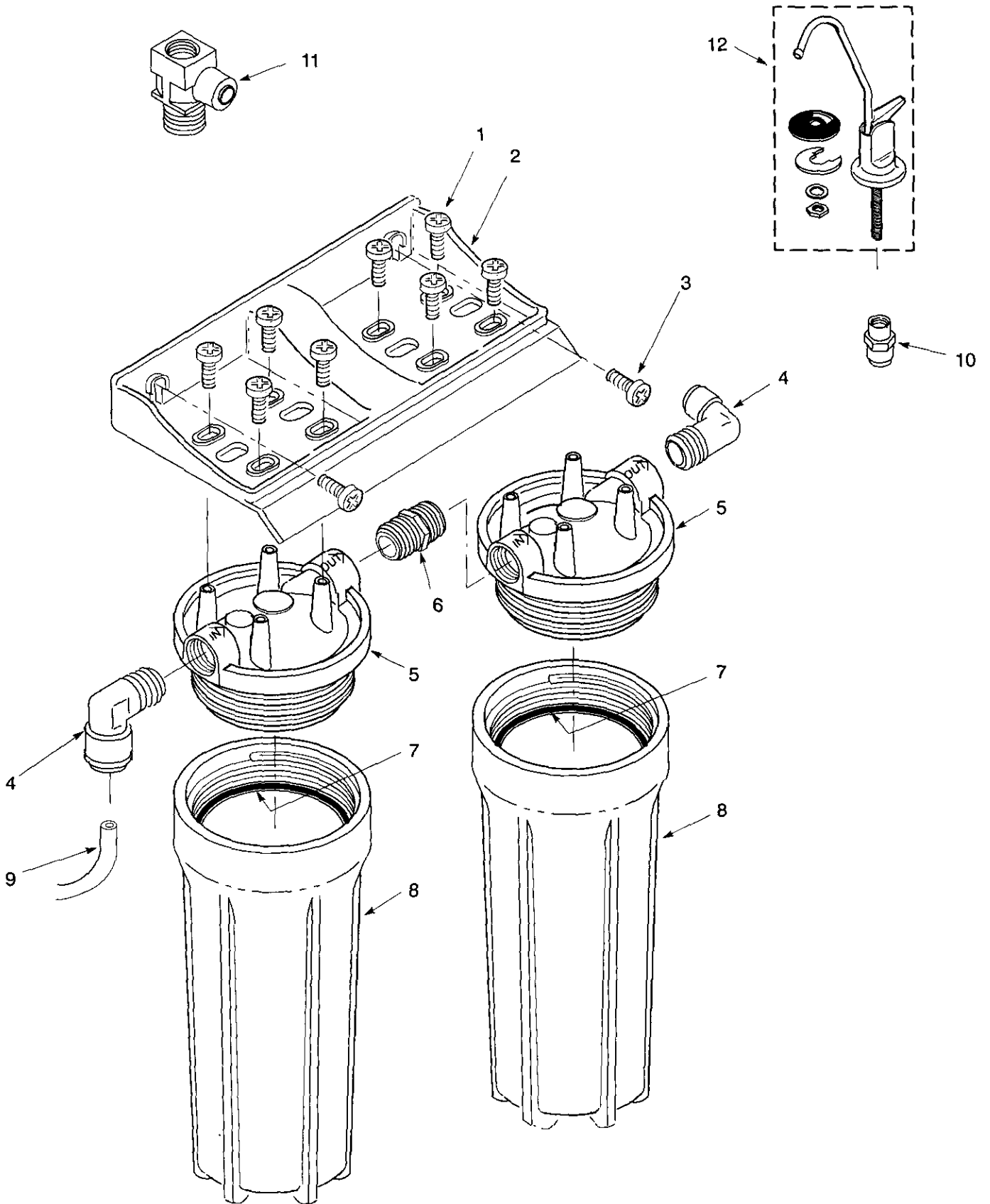

REPAIR PARTS LIST

KEY NO.	PART NUMBER	DESCRIPTION
1	7160453	Screw, #10 - 14 x 3/4" (8 req.)
2	7182502	Mounting Bracket
3	9006053	Screw, #10 - 14 x 1-1/4" (2 req.)
4	7207881	Elbow, 3/8" NPT x 3/8" Tube (2 req.)
5	7156535	Head (2 req.)
6	7161255	Nipple, 3/8" NPT x 1 - 1/2"
7	42-34385	O-ring, 3-3/8" I.D. x 3-5/8" O.D. (2 req.)
8	7156577	Sump (2 req.)
9	7168435	Tubing, 3/8" x 72"
10	7207920	Faucet Adaptor
11	7228536	Tee, Feed Adaptor
12	7228510	Faucet Assembly
◆	7228528	Owners Manual
♣	42-34360	Sediment Cartridge, 25 micron
♣	42-34362	Sediment Cartridge, 5 micron
♣	42-34370	Taste & Odor Cartridge, 95% chlorine reduction
♣	42-34372	Taste & Odor Cartridge, 99% chlorine reduction
♣	42-34365	Taste & Odor / Chemical Contaminant Cartridge
♣	42-34377	Taste & Odor / Lead Cartridge / Cyst
♣	42-34334	Sump Removal Wrench

◆ not illustrated

♣ available options from Sears at time of this printing, not illustrated, and not included with Water Filter System

OWNERS MANUAL

MODEL NO.
625.384600

The model number of your drinking water filter system is found on the rating decal, on the mounting bracket .

When requesting service or ordering parts, always provide the following information:

- ◆ Product Type
- ◆ Model Number
- ◆ Part Number
- ◆ Part Description



UNDERSINK DRINKING WATER FILTER SYSTEM

For the repair or replacement parts you need

Call 7 am - 7 pm, 7 days a week

1 - 800 - 366 - PART

(1 - 800 - 366 - 7278)

For in-home major brand repair service

Call 24 hours a day, 7 days a week

1 - 800 - 4 - REPAIR

(1 - 800 - 473 - 7247)

**For the location of a
Sears Repair Service Center in your area**

Call 24 hours a day, 7 days a week

1 - 800 - 488 - 1222

**For information on purchasing a Sears
Maintenance Agreement, or to inquire
about an existing Agreement**

Call 9 am - 5 pm, Monday - Saturday

1 - 800 - 827 - 6655