

# 7-Quart & 11-Quart Drop-Ins

## INSTALLATION INSTRUCTIONS

### CAUTION

INSPECT CONTENTS IMMEDIATELY AND FILE CLAIM WITH DELIVERING CARRIER FOR ANY DAMAGE.

**SAVE YOUR BOX AND ALL PACKING MATERIALS.**

YOU ARE RESPONSIBLE FOR DAMAGE TO YOUR UNIT IF RETURNED IMPROPERLY PACKED.

#### Step 1 - Cut out holes.

- Cut out holes for the well and for the control panel.

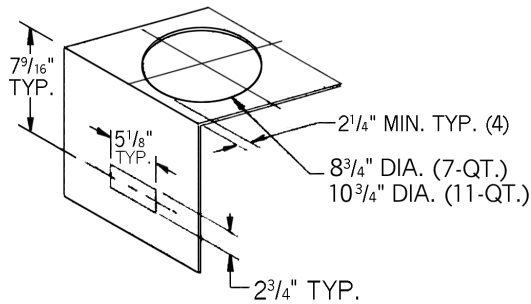

#### Step 2 - Apply silicone rubber.

Apply bead of silicone rubber to underside of drop-in flange.

Note: Silicone can be purchased at a local hardware store.

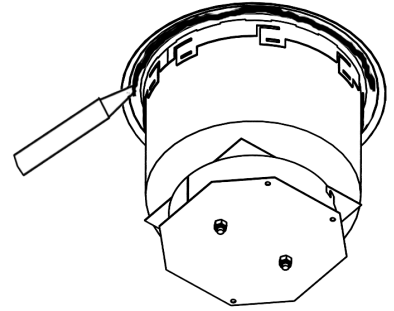

#### Step 3 - Install drop-in.

- Drop control box through top round cutout.
- Set drop-in inside cutout with control facing toward front.
- Insert flat screwdriver into slot of each locking strip tab and twist to secure drop-in to countertop.
- Wipe off excess silicone with clean cloth before it cures.

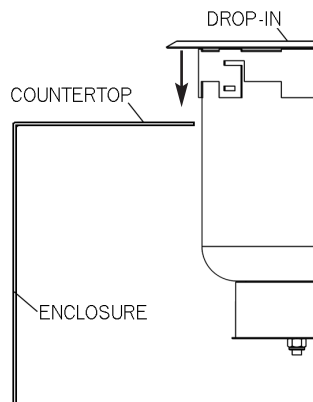

#### Step 4 - Install recess control panel.

- Remove control from recess control panel by removing knob and two mounting screws.
- With indicator light still attached to panel, insert recess control panel thru the 2 3/4 x 5 1/8 cutout from rear of enclosure.
- Remount control to recess control panel and attach knob. Recess control panel should be mounted to enclosure using screws or rivets (not supplied).

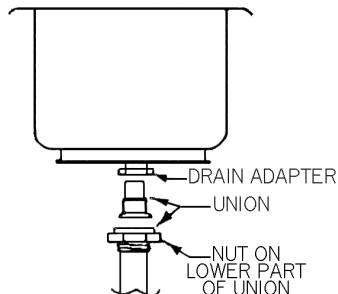
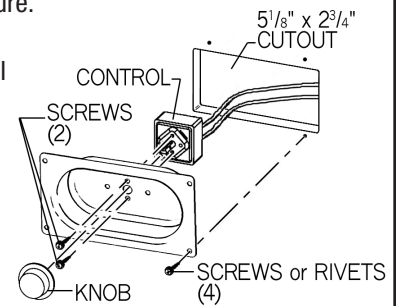

#### PLEASE NOTE – FOR UNITS WITH DRAIN:

- Unit supplied with drain option must have a union installed in drain line directly below drain adapter on bottom of well.
- Union must be installed with nut on lower part to allow removal of heating element.

(For wiring instructions, see reverse side.)

# 7-Quart & 11-Quart Drop-Ins

## INSTALLATION INSTRUCTIONS

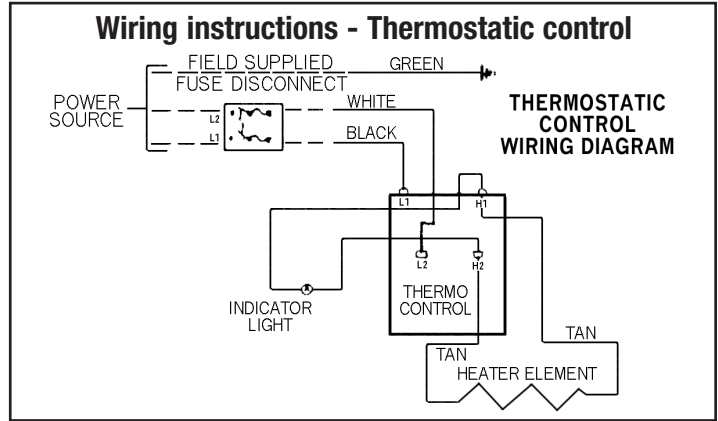
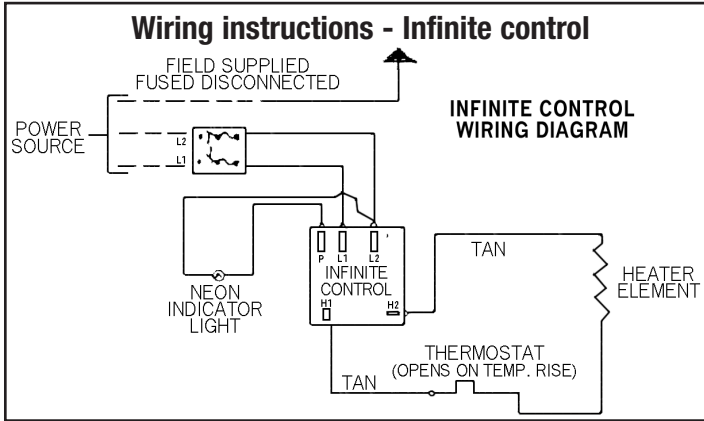

### Please note:

- Connect power supply to 15" power leads.
- Be sure to connect ground to green wire.

Replacement parts may be purchased through our Authorized Parts & Service Center.

## UL CONDITION OF ACCEPTANCY

- 1) This equipment must be installed in an all-metal fixture of stainless steel construction, 0.050" minimum thickness for the top and supporting frame. Side enclosures to be at least 22 MSG.
- 2) A removable bottom enclosure must be provided under each drop-in unit and be of all metal construction of at least 22 MSG. If ventilating openings are provided, they must not allow the entrance of a 3/4"-diameter rod nor be located directly below uninsulated live terminals, wiring or electrical components and must be located at least 1" away from any insulated live terminals.
- 3) Minimum spacing between drop-ins or edges shown in **Step 1** (front page).
- 4) Controls shall be mounted on the front vertical surface of the fixture.
- 5) Cabinet supply wires shall have minimum temperature rating of 220°F (105°C).

(End)

**CAUTION:** Temperature in control area must not exceed 220°F (105°C).

## WARRANTY INFORMATION

### Eagle Hot Food Tables, Cold Pan Units, Portable Warming Equipment, Heated Drawers, and Transport Holding Cabinets

Eagle will warrant for 12 months from the date of shipment from the factory or 6 months from the date first placed into service (whichever comes first). Eagle will replace any defective part or component material upon demonstration to its satisfaction that a breach of warranty did not exist. This warranty does not cover any cost associated with maintenance, misuse, abuse, improper installation, pilot light adjustments, pilot outage, improper ventilation, adjustments, alteration, calibration, wrong voltage, wrong gas, voltage or gas conversions, resetting of circuit breakers, or safety controls, overtime charges, mileage in excess of 100 miles, operation contrary to the installation and operating instructions, damage caused by flood, fire or acts of God. The warranty shall not apply if the nameplate has been removed or altered.

### Eagle Cooking Equipment—including but not limited to all Gas and Electric Griddles, Charbroilers, Hot Plates and Fryers

Eagle will warrant for 12 months from the date of shipment from the factory or 6 months from the date first placed into service (whichever comes first). Units intended for other than household use. These commercial appliances must be installed within surroundings and ventilation requirements as dictated by National and/or local code. This warranty does not cover any cost associated with maintenance, misuse, abuse, improper installation, pilot light adjustments, pilot outage, improper ventilation, adjustments, alteration, calibration, wrong voltage, wrong gas, voltage or gas conversions, resetting of circuit breakers, or safety controls, overtime charges, mileage in excess of 100 miles, operation contrary to the installation and operating instructions, damage caused by flood, fire or acts of God. The warranty shall not apply if the nameplate has been removed or altered.

[CLICK HERE to review full warranty information](#)



- 100 Industrial Boulevard, Clayton, Delaware 19938-8903 U.S.A.
- Phone: 302/653-3000 • 800/441-8440 • Fax: 302/653-2065
- [www.eaglegrp.com](http://www.eaglegrp.com) • [www.eaglegrpnews.com](http://www.eaglegrpnews.com) • [www.eaglemhc.com](http://www.eaglemhc.com)