

Sears

*owners
manual*

MODEL NO.

113.29580

SAW ONLY

113.295820

SAW WITH LEGS AND
TWO TABLE EXTENSIONS

Serial
Number _____

Model and serial
number may be found
at the right-hand side
of the base.

You should record both
model and serial number
in a safe place for
future use.

CAUTION:

Read **GENERAL**
and **ADDITIONAL**
SAFETY
INSTRUCTIONS
carefully

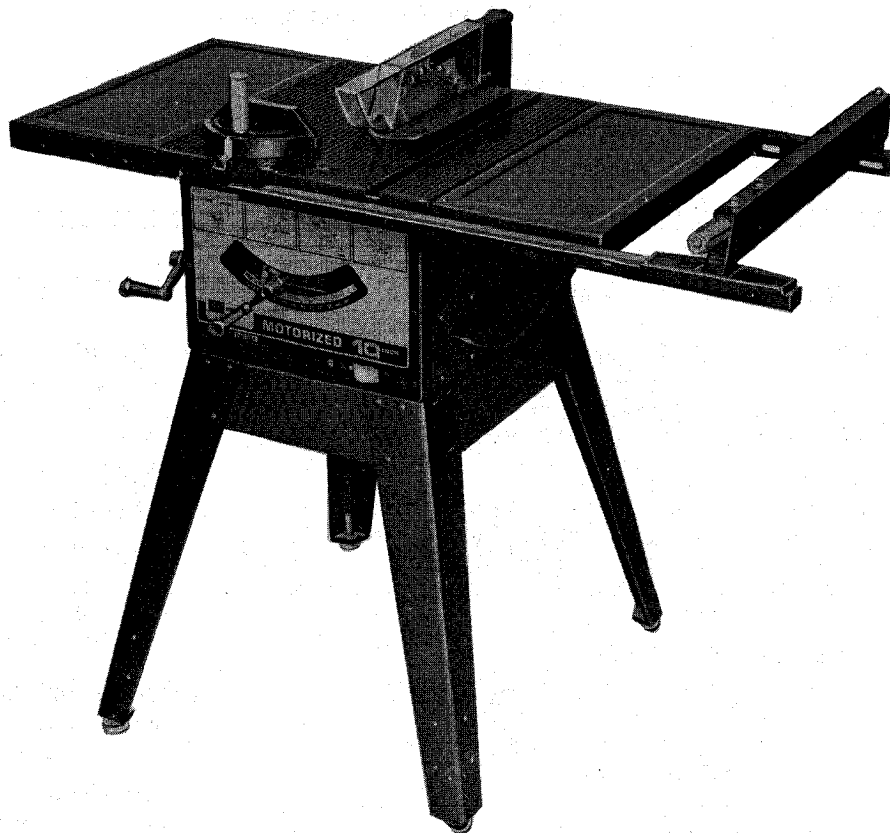

Sears

CRAFTSMAN®

**10-INCH MOTORIZED
TABLE SAW**

- *assembly*
- *operating*
- *repair parts*

Sold by SEARS, ROEBUCK AND CO., Chicago, IL. 60684 U.S.A.

FULL ONE YEAR WARRANTY ON CRAFTSMAN TABLE SAWS

If within one year from the date of purchase, this Craftsman Table Saw fails due to a defect in material or workmanship, Sears will repair it, free of charge.

Warranty service is available by simply contacting the nearest Sears store or Service Center throughout the United States.

This warranty gives you specific legal rights, and you may also have other rights which vary from state to state.

SEARS, ROEBUCK AND CO.
BSC 41-3
SEARS TOWER
CHICAGO, IL 60684

general safety instructions for power tools

- 1. KNOW YOUR POWER TOOL**
Read the owner's manual carefully. Learn its application and limitations as well as the specific potential hazards peculiar to this tool.
- 2. GROUND ALL TOOLS**
This tool is equipped with an approved 3-conductor cord and a 3-prong grounding type plug to fit the proper grounding type receptacle. The green conductor in the cord is the grounding wire. Never connect the green wire to a live terminal.
- 3. KEEP GUARDS IN PLACE**
in working order, and in proper adjustment and alignment.
- 4. REMOVE ADJUSTING KEYS AND WRENCHES**
Form habit of checking to see that keys and adjusting wrenches are removed from tool before turning it on.
- 5. KEEP WORK AREA CLEAN**
Cluttered areas and benches invite accidents. Floor must not be slippery due to wax or sawdust.
- 6. AVOID DANGEROUS ENVIRONMENT**
Don't use power tools in damp or wet locations or expose them to rain. Keep work area well lighted. Provide adequate surrounding work space.
- 7. KEEP CHILDREN AWAY**
All visitors should be kept a safe distance from work area.
- 8. MAKE WORKSHOP KID-PROOF**
— with padlocks, master switches, or by removing starter keys.
- 9. DON'T FORCE TOOL**
It will do the job better and safer at the rate for which it was designed.
- 10. USE RIGHT TOOL**
Don't force tool or attachment to do a job it was not designed for.
- 11. WEAR PROPER APPAREL**
Do not wear loose clothing, gloves, neckties or jewelry (rings, wrist watches) to get caught in moving parts. Non-slip footwear is recommended. Wear protective hair covering to contain long hair. Roll long sleeves above the elbow.
- 12. USE SAFETY GOGGLES (Head Protection)**
Wear Safety goggles (must comply with ANS Z87.1) at all times. Also, use face or dust mask if cutting operation is dusty, and ear protectors (plugs or muffs) during extended periods of operation.
- 13. SECURE WORK**
Use clamps or a vise to hold work when practical. It's safer than using your hand, frees both hands to operate tool.
- 14. DON'T OVERREACH**
Keep proper footing and balance at all times.
- 15. MAINTAIN TOOLS WITH CARE**
Keep tools sharp and clean for best and safest performance. Follow instructions for lubricating and changing accessories.
- 16. DISCONNECT TOOLS**
before servicing; when changing accessories such as blades, bits, cutters, etc.
- 17. AVOID ACCIDENTAL STARTING**
Make sure switch is in "OFF" position before plugging in.
- 18. USE RECOMMENDED ACCESSORIES**
Consult the owner's manual for recommended accessories. Follow the instructions that accompany the accessories. The use of improper accessories may cause hazards.
- 19. NEVER STAND ON TOOL**
Serious injury could occur if the tool is tipped or if the cutting tool is accidentally contacted.
Do not store materials above or near the tool such that it is necessary to stand on the tool to reach them.
- 20. CHECK DAMAGED PARTS**
Before further use of the tool, a guard or other part that is damaged should be carefully checked to ensure that it will operate properly and perform its intended function. Check for alignment of moving parts, binding of moving parts, breakage of parts, mounting, and any other conditions that may affect its operation. A guard or other part that is damaged should be properly repaired or replaced.
- 21. DIRECTION OF FEED**
Feed work into a blade or cutter against the direction of rotation of the blade or cutter only.
- 22. NEVER LEAVE TOOL RUNNING UNATTENDED**
Turn power off. Don't leave tool until it comes to a complete stop.

ADDITIONAL SAFETY INSTRUCTIONS FOR TABLE SAWS

WARNING: FOR YOUR OWN SAFETY, DO NOT OPERATE YOUR SAW UNTIL IT IS COMPLETELY ASSEMBLED AND INSTALLED ACCORDING TO THE INSTRUCTIONS ... AND UNTIL YOU HAVE READ AND UNDERSTOOD THE FOLLOWING.

1. **GENERAL SAFETY INSTRUCTIONS FOR POWER TOOLS ... SEE PAGE 2**
2. **GETTING TO KNOW YOUR SAW ... SEE PAGE 15**
3. **BASIC SAW OPERATION ... SEE PAGE 17**
4. **ADJUSTMENTS ... SEE PAGE 23**
5. **MAINTENANCE ... SEE PAGE 26**
6. **STABILITY OF SAW**

If there is any tendency for the saw to tip over or move during certain cutting operations such as cutting extremely large heavy panels or long heavy boards, the saw should be bolted down.

If you attach any kind of table extensions over 24 in. wide, make sure they are supported underneath by a sturdy brace attached to saw base or bench.

7. LOCATION

The saw should be positioned so neither the operator nor a casual observer is forced to stand in line with the saw blade.

8. KICKBACKS

Kickbacks can cause serious injury: A "KICKBACK" occurs when a part of the workpiece binds between the sawblade and the rip fence or other fixed object, rises from the table, and is thrown toward the operator.

Keep your face and body to one side of the sawblade, out of line with a possible "Kickback."

Kickbacks — and possible injury from them — can usually be avoided by:

- A. Maintaining the rip fence parallel to the sawblade.
- B. Keeping the sawblade sharp. Replace or sharpen antikickback pawls when points become dull.
- C. Keeping sawblade guard, spreader, and antikickback pawls in place and operating properly. The spreader must be in alignment with the sawblade and the pawls must stop a kickback once it has started. Check their action before ripping.
- D. NOT ripping work that is twisted or warped or does not have a straight edge to guide along the rip fence.
- E. NOT releasing work until you have pushed it all the way past the sawblade.
- F. Using a "PUSH-STICK" for ripping widths of 2 to 6 in., and an auxiliary fence and push block for ripping widths narrower than 2 in. (See "Basic Saw Operation Using The Rip Fence" section.)
- G. NOT confining the cut-off piece when ripping or cross-cutting.
- H. When ripping apply the feed force to the section of the workpiece between the saw blade and the rip fence.

9. PROTECTION: EYES, HANDS, FACE, EARS, BODY

- A. If any part of your saw is malfunctioning, has been damaged or broken ... such as the motor switch, or other operating control, a safety device or the power cord ... cease operating immediately until the particular part is properly repaired or replaced.
- B. Wear safety goggles that comply with ANS Z87.1, and a face shield if operation is dusty. Wear ear plugs or muffs during extended periods of operation.
- C. Small loose pieces of wood or other objects that contact the rear of the revolving blade can be

thrown back at the operator at excessive speed. This can usually be avoided by keeping the guard and spreader in place for all "THRU-SAWING" operations (sawing entirely thru the work) AND by removing all loose pieces from the table with a long stick of wood IMMEDIATELY after they are cut off.

- D. Use extra caution when the guard assembly is removed for resawing, dadoing, rabbeting, or molding — replace the guard as soon as that operation is completed.
 - E. NEVER turn the saw "ON" before clearing the table of all tools, wood scraps, etc., except the workpiece and related feed or support devices for the operation planned.
 - F. NEVER place your face or body in line with the cutting tool.
 - G. NEVER place your fingers or hands in the path of the sawblade or other cutting tool.
 - H. NEVER reach in back of the cutting tool with either hand to hold down or support the workpiece, remove wood scraps, or for any other reason. Avoid awkward operations and hand positions where a sudden slip could cause fingers or hand to move into a sawblade or other cutting tool.
1. DO NOT perform any operation "FREEHAND" — always use either the rip fence or the miter gauge to position and guide the work.
 - J. NEVER use the rip fence when crosscutting or the miter gauge when ripping. DO NOT use the rip fence as a length stop.
Never hold onto or touch the "free end" of the workpiece or a "free piece" that is cut off, while power is "ON" and/or the sawblade is rotating.
 - K. Shut "OFF" the saw and disconnect the power cord when removing the table insert, changing the cutting tool, removing or replacing the blade guard, or making adjustments.
 - L. Provide adequate support to the rear and sides of the saw table for wider or long workpieces.
 - M. Plastic and composition (like hardboard) materials may be cut on your saw. However, since these are usually quite hard and slippery, the antikickback pawls may not stop a kickback.
Therefore, be especially attentive to following proper set-up and cutting procedures for ripping. Do not stand, or permit anyone else to stand, in line with a potential kickback.
 - N. DO NOT Perform layout, assembly, or set-up work on the table while cutting tool is rotating.
 - O. If you stall or jam the sawblade in the workpiece, turn saw "OFF", remove the workpiece from the sawblade, and check to see if the sawblade is parallel to the miter gauge grooves and if the spreader is in proper alignment with the sawblade. If ripping at the time, check to see if the rip fence is parallel with the sawblade. Readjust as indicated.

10. KNOW YOUR CUTTING TOOLS

- A. Dull, gummy, or improperly sharpened or set cutting tools can cause material to stick, jam, stall the saw, or kickback at the operator.
Minimize potential injury by proper cutting tool and machine maintenance.
NEVER ATTEMPT TO FREE A STALLED SAWBLADE WITHOUT FIRST TURNING THE SAW OFF.

B. Never use grinding wheels, abrasive cut-off wheels, friction wheels (metal slitting blades) wire wheels or buffing wheels.

11. USE ONLY ACCESSORIES DESIGNED FOR THIS SAW.

12. Crosscutting operations are more conveniently worked and with greater safety if an auxiliary wood facing is attached to the miter gauge using the holes provided. However, the facing must not interfere with the proper functioning of the sawblade guard.

13. Make sure the top of the arbor or cutting tool rotates toward you when standing in normal operating position. Also make sure the cutting tool, arbor collars and arbor nut are installed properly. Keep the cutting tool as low as possible for the operation being performed. Keep all guards in place whenever possible.

14. Do not use any blade or other cutting tool marked for an operating speed less than 3450 RPM. Never use a cutting tool larger in diameter than the diameter for which the saw was designed. For greatest safety and efficiency when ripping, use the maximum diameter blade for which the saw is designed, since under these conditions the spreader is nearest the blade.

15. Adjust table inserts flush with the table top. **NEVER** Operate the saw unless the proper insert is installed.

16. NEVER FEED MATERIAL INTO THE CUTTING TOOL FROM THE REAR OF THE SAW. An accident and serious injury could result.

17. THINK SAFETY.

Safety is a combination of operator common sense and alertness at all times when the saw is being used.

18. NOTE AND FOLLOW SAFETY INSTRUCTIONS THAT APPEAR ON THE FRONT OF YOUR SAW.

DANGER

FOR YOUR OWN SAFETY

READ AND UNDERSTAND OWNER'S MANUAL

BEFORE OPERATING MACHINE:

1. WEAR SAFETY GOGGLES
2. USE SAW-BLADE GUARD FOR "THRU-SAWING"
3. KEEP HANDS OUT OF PATH OF SAWBLADE
4. USE A "PUSH-STICK" WHEN REQUIRED
5. KNOW HOW TO AVOID "KICKBACKS"
6. DO NOT PERFORM OPERATIONS "FREEHAND"

19. WARNING: DO NOT ALLOW FAMILIARITY (GAINED FROM FREQUENT USE OF YOUR SAW) TO BECOME COMMONPLACE. - ALWAYS REMEMBER THAT A CARELESS FRACTION OF A SECOND IS SUFFICIENT TO INFLICT SEVERE INJURY.



The operation of any power tool can result in foreign objects being thrown into the eyes, which can result in severe eye damage. Always wear safety goggles complying with ANSI Z87.1 (shown on Package) before commencing power tool operation. Safety Goggles are available at Sears retail or catalog stores.

MOTOR SPECIFICATIONS AND ELECTRICAL REQUIREMENTS

MOTOR SPECIFICATIONS

The AC motor used in this saw is a capacitor start, non-reversible type, with the following specifications:

Voltage	120
Amperes	12
Hertz	60
Phase	Single
RPM	3450
Rotation (viewed from Sawblade end)	Counterclockwise

MOTOR SAFETY PROTECTION

The saw motor is equipped with a manual-reset thermal overload protector, designed to open the power line circuit when the motor temperature exceeds a safe value.

NOTE: The starting relay is a GRAVITY SENSITIVE TYPE. NEVER TURN THE POWER ON WHILE THE SAW IS UPSIDE DOWN AS THIS WILL DAMAGE THE MOTOR.

1. If the protector opens the line and stops the saw motor, move the saw switch lever to the "OFF" position immediately and allow the motor to cool.
2. After cooling to a safe operating temperature, the overload protector can be closed manually by pushing in the red RESET button on the front of the saw. If the red button will not snap into place immediately, the motor is still too hot and must be allowed to cool for a while longer.

3. As soon as the red button will snap into running position, the saw may be started and operated normally by moving the saw switch lever to the "ON" position.

4. Frequent opening of fuses or circuit breakers may result if motor is overloaded, or if the motor circuit is fused with a fuse other than those recommended. Do not use a fuse of greater capacity without consulting the power company.

5. Although the motor is designed for operation on the voltage and frequency specified on motor nameplate, normal loads will be handled safely on voltages not more than 10% above or below the nameplate voltage. Heavy loads, however, require that voltage at motor terminals by not less than the voltage specified on nameplate.

6. Most motor troubles may be traced to loose or incorrect connections, overloading, reduced input voltage (which results when small size wires are used in the supply circuit) or when the supply circuit is extremely long. Always check connection, load and supply circuit when the motor fails to perform satisfactorily. Check wire sizes and lengths with table at end of this section.

CONNECTING TO POWER SOURCE OUTLET

This saw must be grounded while in use to protect the operator from electrical shock.

If power cord is worn or cut, or damaged in any way, have it replaced immediately.



If your saw is for use on less than 150 volts it has a plug that looks like below.

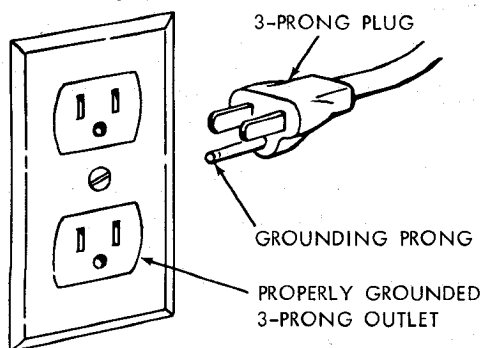

Plug power cord into 110-120V properly grounded type outlet protected by a 15-amp. time delay or Circuit-Saver fuse or circuit breaker.

IF YOU ARE NOT SURE THAT YOUR OUTLET IS PROPERLY GROUNDED, HAVE IT CHECKED BY A QUALIFIED ELECTRICIAN.

WARNING: DO NOT PERMIT FINGERS TO TOUCH THE TERMINALS OF PLUG WHEN INSTALLING OR REMOVING THE PLUG TO OR FROM THE OUTLET.

WARNING: IF NOT PROPERLY GROUNDED THIS POWER TOOL CAN INCUR THE POTENTIAL HAZARD OF ELECTRICAL SHOCK, PARTICULARLY WHEN USED IN DAMP LOCATIONS; IN PROXIMITY TO PLUMBING, OR OUT OF DOORS. IF AN ELECTRICAL SHOCK OCCURS THERE IS THE POTENTIAL OF A SECONDARY HAZARD SUCH AS YOUR HANDS CONTACTING THE SAWBLADE.

This saw is equipped with a 3-conductor cord and grounding type plug which has a grounding prong, approved by Underwriters' Laboratories and the Canadian Standards Association. The ground conductor has a green lug and is attached to the tool housing at one end and to the ground prong in the attachment plug at the other end.

This plug requires a mating 3-conductor grounded type outlet as shown.

If the outlet you are planning to use for this saw is of the two prong type **DO NOT REMOVE OR ALTER THE GROUNDING PRONG IN ANY MANNER.** Use an adapter as shown and always connect the grounding lug to a known ground.

It is recommended that you have a qualified electrician replace the TWO prong outlet with a properly grounded THREE prong outlet.

An adapter as shown below is available for connecting plugs to 2-prong receptacles. The green grounding lug extending from the adapter must be connected to a permanent ground such as to a properly grounded outlet box.

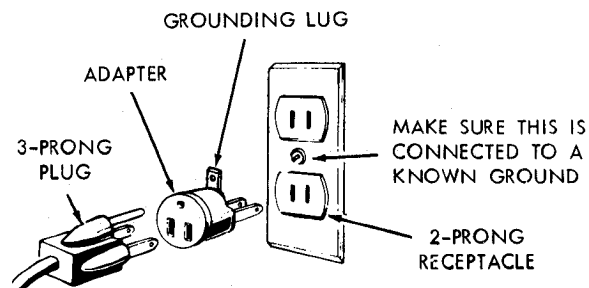

NOTE: The adapter illustrated is for use only if you already have a properly grounded 2-prong receptacle. Adapter is not allowed in Canada by the Canadian Electrical Code.

The use of any extension cord will cause some loss of power. To keep this to a minimum and to prevent over-heating and motor burn-out, use the table below to determine the minimum wire size (A.W.G.) extension cord. Use only 3 wire extension cords which have 3 prong grounding type plugs and 3-pole receptacles which will accept the plug on the saw.

Extension Cord Length	Wire Size A.W.G.
Up to 100 Ft.	12
100 - 200 Ft.	10
200 - 400 Ft.	8

CONTENTS

WARRANTY	2
GENERAL SAFETY INSTRUCTIONS FOR POWER TOOLS	2
ADDITIONAL SAFETY INSTRUCTIONS FOR TABLE SAWS	3
MOTOR SPECIFICATIONS AND ELECTRICAL REQUIREMENTS	4
UNPACKING AND CHECKING CONTENTS	6
Tools Needed	6
List of Loose Parts	6
ASSEMBLY	7
Installing Elevation and Tilt Cranks	7
Checking Table Insert	7
Checking Blade Squareness to Table	8
Checking Blade Elevation	8
Attaching Table Extensions	8
Installing Rip Fence Guide Bars	9
Assembling Steel Legs	10
Mounting Saw	10
Aligning Table Extensions	11
Aligning Rip Fence	11
Installing Blade Guard	13
GETTING TO KNOW YOUR SAW	15
On-Off Switch	15
Reset Button	16
Elevation Crank	16
Tilt Crank	16
Rip Fence	16
Miter Gauge	16

Blade Guard	16
Table Insert	16
Removing and Installing Saw Blade	17
BASIC SAW OPERATION USING THE MITER GAUGE	17
Work Helpers	17
Crosscutting	18
Repetitive Cutting	19
Miter Cutting	20
Bevel Crosscutting	20
Compound Miter Cutting	20
BASIC SAW OPERATION USING THE RIP FENCE	20
Ripping	21
Bevel Ripping	21
Resawing	22
Cutting Panels	23
Rabbeting	23
ADJUSTMENTS	23
Miter Gauge	23
Heeling Adjustment or Parallelism of Sawblade to Miter Gauge Groove	24
Blade Tilt, or Squareness of Blade to Table	24
Blade Elevation	26
Tilt and Elevation Mechanism	26
MAINTENANCE	26
LUBRICATION	27
RECOMMENDED ACCESSORIES	27
TROUBLE SHOOTING	28
REPAIR PARTS	30

UNPACKING AND CHECKING CONTENTS

TOOLS NEEDED

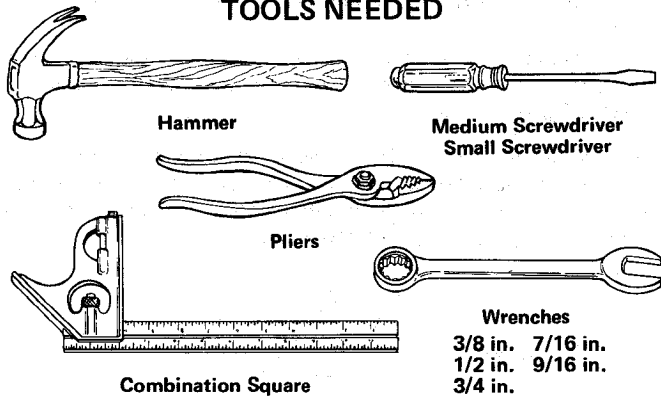

COMBINATION SQUARE MUST BE TRUE.

STRAIGHT EDGE OF BOARD
3/4" THICK. THIS EDGE MUST
BE PERFECTLY STRAIGHT.
DRAW LIGHT LINE ON
BOARD ALONG THIS EDGE.

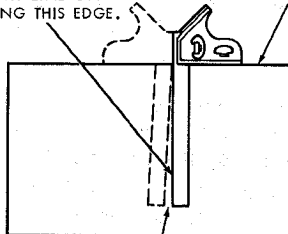

SHOULD BE NO GAP OR OVERLAP
HERE WHEN SQUARE IS FLIPPED
OVER IN DOTTED POSITION.

Model 113.29580 Motorized Table Saw is shipped complete in one carton but **DOES NOT INCLUDE** Table Extensions and Steel Legs.

Model 113.295820 Motorized Table Saw is shipped complete in one carton but **INCLUDES TWO** Table Extensions and Steel Legs.

Separate all parts from packing materials and check each one with the illustration and the list of Loose Parts to make certain all items are accounted for, before discarding any packing material.

If any parts are missing, do not attempt to assemble the table saw, plug in the power cord or turn the switch on until the missing parts are obtained and are installed correctly.

WARNING: FOR YOUR OWN SAFETY, NEVER CONNECT PLUG TO POWER SOURCE OUTLET UNTIL ALL ASSEMBLY STEPS ARE COMPLETE, AND YOU HAVE READ AND UNDERSTAND THE SAFETY AND OPERATIONAL INSTRUCTIONS.

LIST OF LOOSE PARTS

Key No.	Part Name	Qty.
1	Miter Gauge	1
2	Rip Fence	1
3	Blade Guard and Spreader	1
4	Crank	2
5	Rip Fence Guide Bar, Rear	1
6	Rip Fence Guide Bar Rod	1
7	Rip Fence Guide Bar with Rip Scale (Front)	1
8	Arbor Wrench	1
9	Arbor Nut Wrench	1
10	Owners Manual	1
	Pkg. of Miscellaneous Small Parts, No. 62658	
	Consisting of the Following:	
11	Spreader Support	1
12	Spreader Clamp	1
13	Spreader Bracket	1
14	Setscrew Wrench, 1/8 in.	1
14	Setscrew Wrench, 3/16 in.	1
15	Switch Key	2
16	Guide Bar Spacer	2
17	Soc. Hd. Set Screw 1/4-20 x 7/8	2
18	Square Nut, 1/4-20	2
19	Self Threading Nut	2
20	Flatwasher, (dia. of hole 17/64 in.)	4
20	Flatwasher, (dia. of hole 21/64 in.)	4
21	Hex Nut, 1/4 in. - 20	
	(approx. dia. of hole 1/4 in.)	2
21	Hex Nut, 5/16 in. - 20	
	(approx. dia. of hole 5/16 in.)	4
22	Lockwasher, 1/4 in. External Type	
	(approx. dia. of hole 1/4 in.)	4

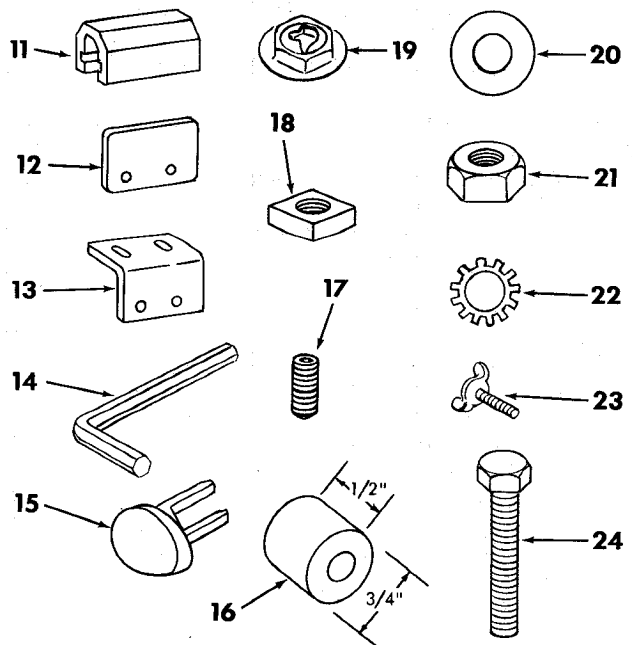
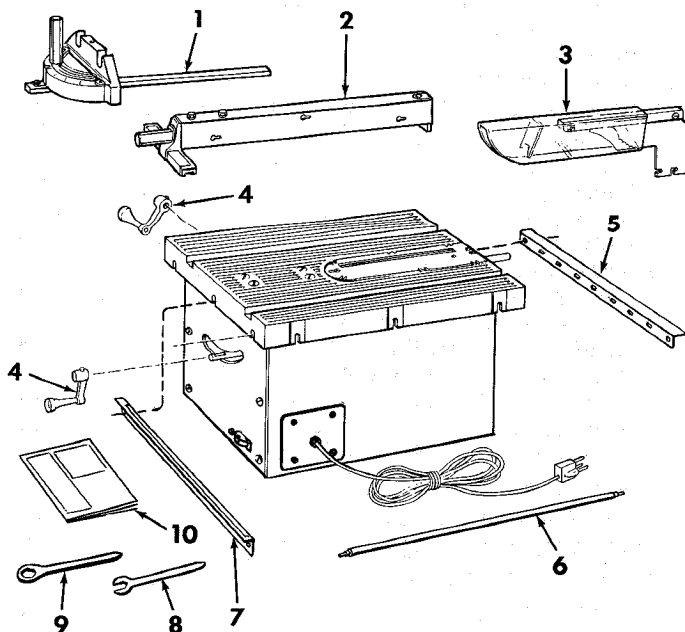

22	Lockwasher, 5/16 in. External Type (approx. dia. of hole 5/16 in.)	4
23	Wing Screw, 1/4 in.-20 x 1/2 in. long	2
24	Hex Hd. Screw, 5/16 - 18 x 1-1/2 in. long	2
24	Hex Hd. Screw, 5/16 - 18 x 1 in. long	2

The following parts are included with Model 113.295820
(NOT SUPPLIED IN CANADA)

Key		
No.	Part Name	Qty.
1	Leg	4
2	Side Stiffener	2
3	End Stiffener	2
4	Table Extension	2
Pkg. of Miscellaneous Small Parts, No. 62659 Consisting of the Following:		
5	Hex Head Screw 5/16 in.-18 x 1-1/4 in. long	6
6	Lockwasher, 1/4 in. External Type (approx. dia. of hole 1/4 in.)	24
6	Lockwasher, 5/16 in. External Type (approx. dia. of hole 5/16 in.)	6
7	Hex Nut, 1/4 in.-20 (approx. dia. of hole 1/4 in.)	24
7	Hex Nut, 5/16 in.-18 (approx. dia. of hole 5/16 in.)	6
7	Hex Nut, 1/2 in.-13 (approx. dia. of hole 1/2 in.)	8

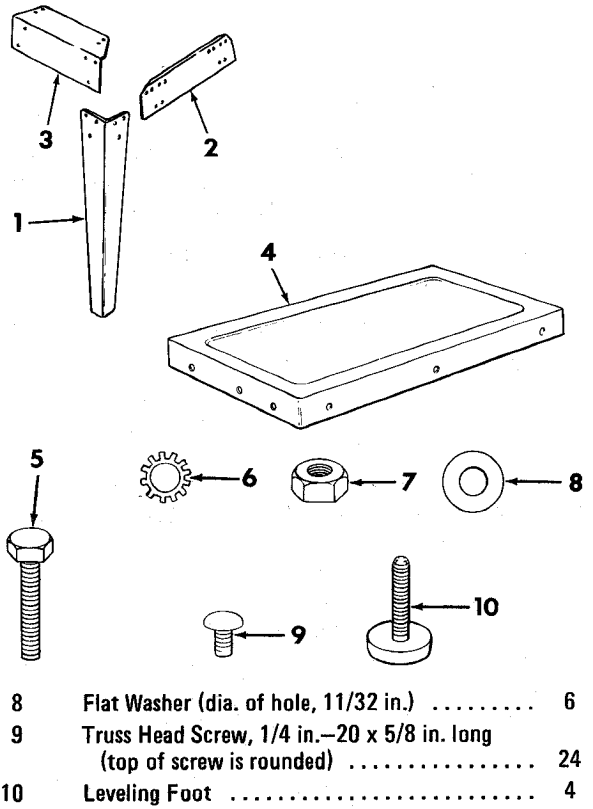

ASSEMBLY

Before mounting the saw on legs, a stand or a bench, the Table Insert and Blade Squareness and Blade Elevation must be checked at this time.

INSTALLING ELEVATION AND TILT CRANKS

- Line up set screw in cranks with **FLAT SPOTS** on shafts . . . tighten screws using 1/8 in. set screw wrench furnished with saw.

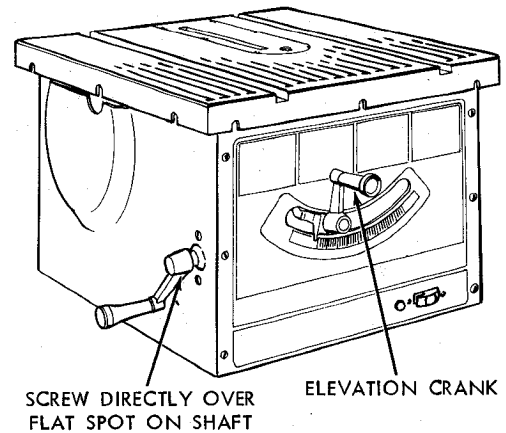

CHECKING TABLE INSERT

- With the insert in place, and sawblade all the way down, use a small scale or straight edge to check near each of the eight leveling tab positions, in order to determine if the insert is flush with saw table surface at all eight tab locations.
- If the insert is above the table surface, the leveling tabs must be adjusted.
 - Loosen Screw.
 - Lift insert from front end, and pull toward front of saw.
 - Remove the insert, place it upside down on your workbench and **GENTLY TAP** each of the tabs downward only a slight amount. Replace insert . . . check it and readjust tabs, if necessary.

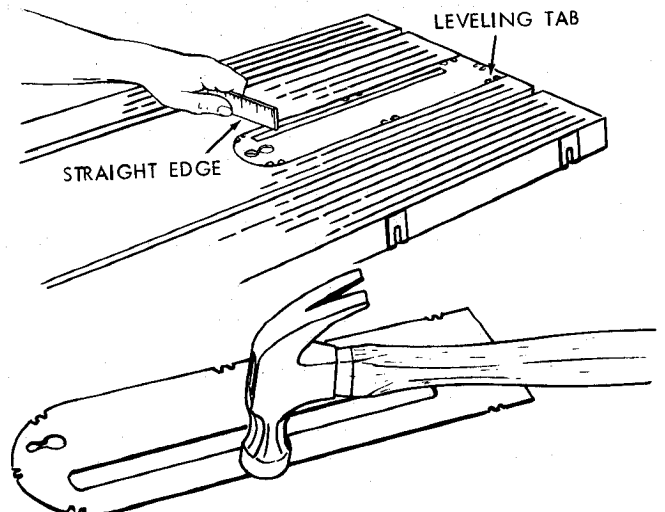

3. If the insert is **BELOW** the table surface, remove the insert and bend the tabs (with pliers) enough to make the insert **ABOVE** the table surface.
4. Re-install insert and adjust as described under "2".

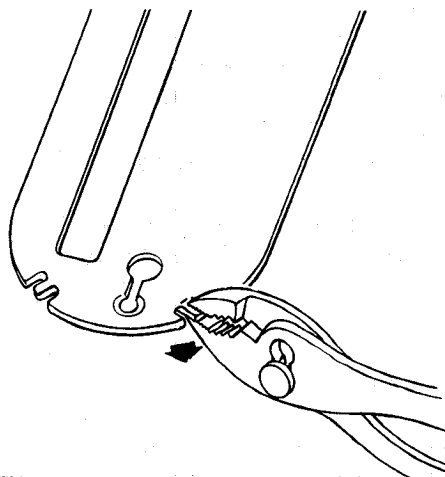

DO NOT TIGHTEN SCREW TO THE POINT WHERE IT DEFLECTS THE INSERT.

CHECKING BLADE SQUARENESS TO TABLE

IMPORTANT: BLADE must be **SQUARE** (90°) to TABLE, in order to proceed with assembly.

1. Turn **ELEVATION** crank counterclockwise until blade is up as high as it will go.
2. Check for **BLADE SQUARENESS** . . . if blade is not square to table, adjust it at this time.

NOTE: The Combination Square must be "TRUE" — See start of "Unpacking and Checking Contents" section on page 6 for checking method.

Refer to "BLADE TILT, OR SQUARENESS OF BLADE TO TABLE" adjustments on page 24.

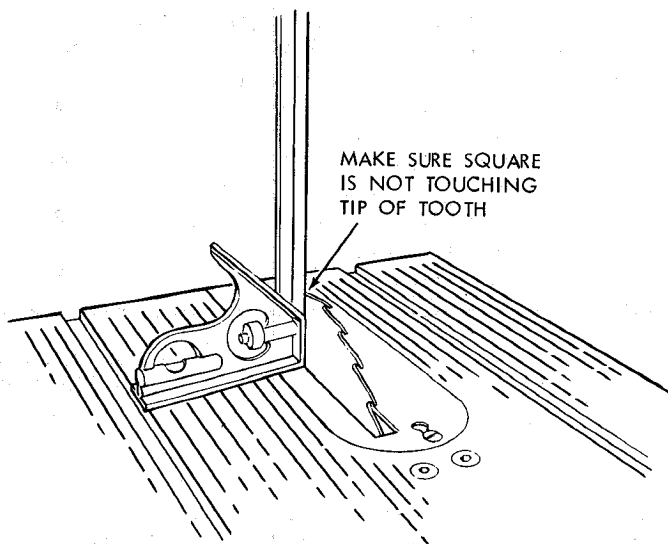

CHECKING BLADE ELEVATION

Maximum depth of cut **MUST NOT EXCEED TWO AND ONE HALF (2-1/2) INCHES**. This adjustment is set at the factory and should be checked to make sure that it has not changed due to rough handling during shipment.

With the blade up as high as it will go, measure the distance from the top of the table to top of the highest saw tooth. If it is more than two inches, adjust it at this time. Refer to "BLADE ELEVATION" adjustments on page 26.

ATTACHING TABLE EXTENSIONS

If you received two Table Extensions with your saw (furnished with Model No. 113.295820) attach them at this time.

1. Position saw upside down on floor.

NOTE: To protect the finished surfaces of the saw and extensions, lay a piece of heavy paper on the floor.

2. From among the loose parts find the following hardware:
 - 6 Hex Head Screws 5/16. — 18 x 1 in. long
 - 6 Lockwashers, 5/16 in. External Type (approx. dia. of hole 5/16 in.)
 - 6 Flat Washers (dia. of hole 11/32 in.)
 - 6 Hex Nuts, 5/16 in. — 18 (approx. dia. of hole 5/16 in.)
3. Install screws, washers, and nuts for extensions as shown . . . tighten screws **SLIGHTLY**.
BE SURE END OF EXTENSIONS ARE EVEN WITH FRONT EDGE OF SAW.
4. Leave saw in upside down position until you attach the rip fence guide bars and legs.

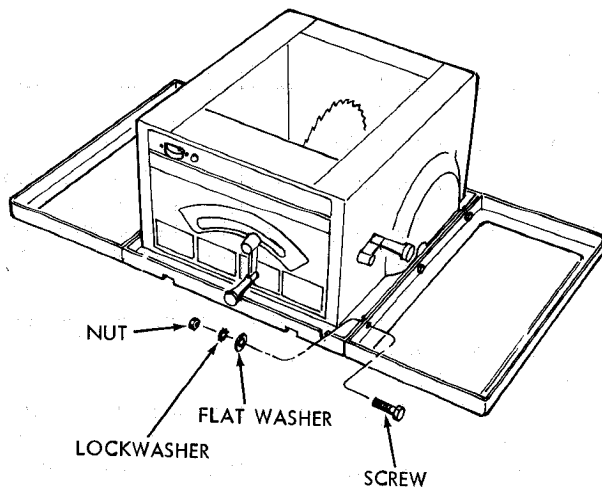

INSTALLING RIP FENCE GUIDE BARS

- From among the loose parts find the following hardware:
 - 2 Hex. Head Screws, 5/16 in. - 18 x 1-1/2 in. long
 - 2 Hex. Head Screws, 5/16 in. - 18 x 1 in. long
 - 4 Hex. Nuts, 5/16 in. - 18 (approx. dia. of hole 5/16 in.)
 - 4 External Lockwashers, 5/16 in. (approx. dia. of hole 5/16 in.)
 - 4 Flat Washers (Dia. of hole 21/64 in.)
 - 2 Spacers, 3/4 in. dia. x 1/2 in. long
 - 2 Self-threading nuts
- Position guide bars on floor and install hardware as shown . . . do not screw nuts on all the way.

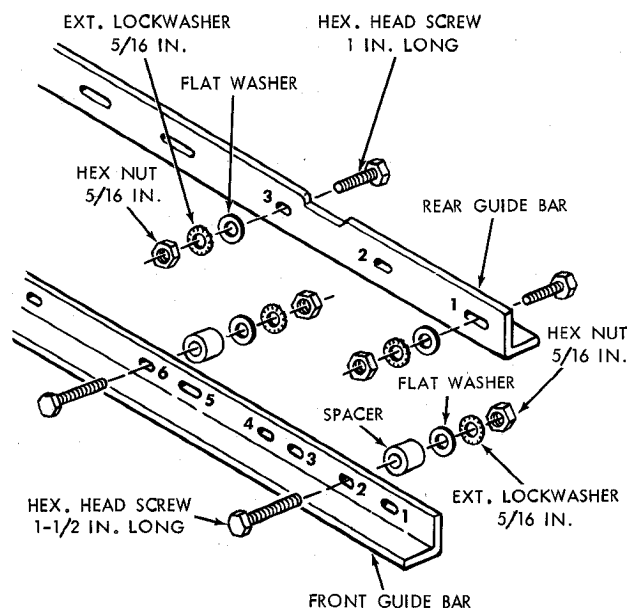

- Place front guide bar against saw table and drop it in place . . . engaging the screws in the slots. Make sure the spacers are between the rail and the table.
- End of front guide bar must be 5 13/16 in. from side of saw table. This is important so that rip fence pointer can be aligned.
- With the blade of your combination square set to 1/4 in., use it as a gauge and attach the rail so that the edge of the rail is 1/4 in. ABOVE the edge of the table.

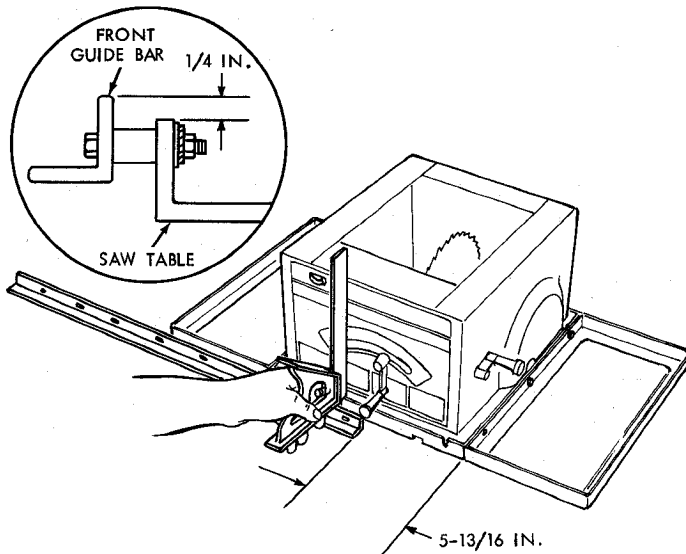

- Remove the three screws from rear of table extension.
- Insert ends of FENCE GUIDE BAR ROD through round holes at outer end of bars.

NOTE: The ends of the ROD are not threaded . . . the SELF THREADING NUTS will cut threads on the rod as they are screwed on.
- Attach the rear bar in a similar manner, but make sure that the end of the bar is 8 5/8 in. from the side of the saw table.

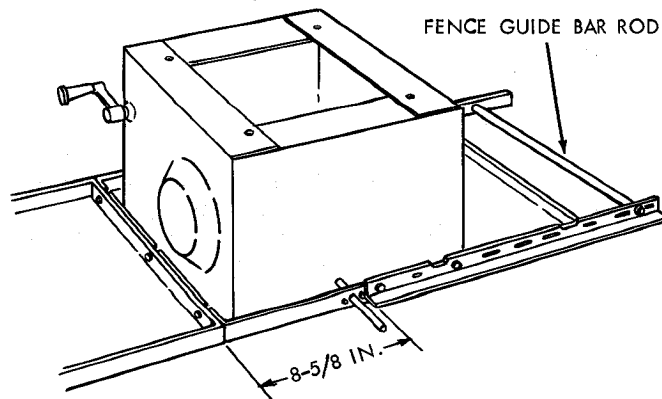

ASSEMBLING STEEL LEGS

NOTE: Steel Legs are furnished with Model 113.295820. From among the loose parts, find the following Hardware:

- 24 Truss Head Screws, 1/4 in. – 20 x 5/8 in. long (top of screw is rounded)
- 24 Lockwashers, 1/4 in. External Type (approx. dia. of hole 1/4 in.)
- 24 Hex Nuts, 1/4 in. – 20 (approx. dia. of hole 1/4 in.)
- 8 Hex Nuts, 1/2 in. – 13 (approx. dia. of hole 1/2 in.)
- 4 Leveling feet.

Assemble the legs as shown . . .

1. Insert the Truss Head Screws through the holes in the legs, then through the holes in the stiffeners. **MAKE SURE THE SCREWS GO THROUGH THE HOLES IN THE SIDE STIFFENERS MARKED "X"**.
2. Screw on the nuts but do not tighten until completely assembled.
3. Install leveling feet.

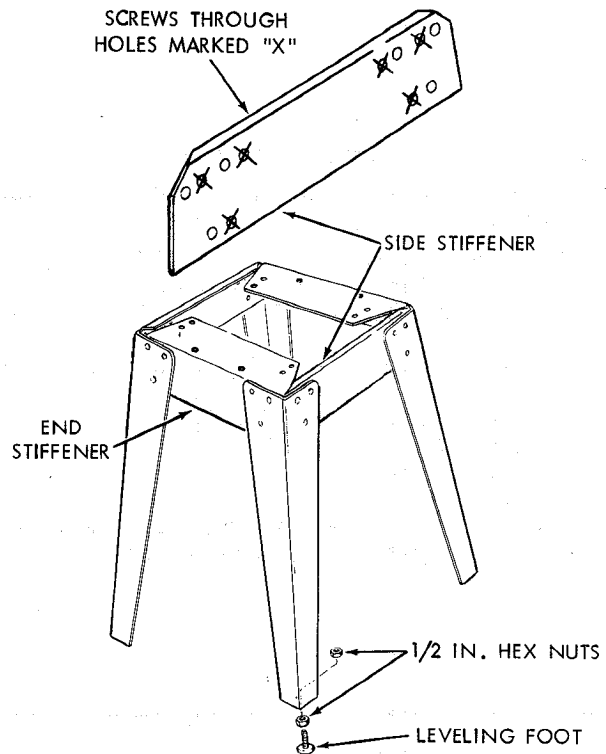

MOUNTING SAW

1. Remove the four Truss Head screws, flatwashers, lockwashers and nuts from bottom of saw.
2. Position legs as shown and line up holes in stiffeners with holes in saw base.

NOTE: At front of saw you will see four sets of holes. Insert bolts through holes closest to front of saw . . . these holes are 9-1/4" apart.

Replace the screws, washers and nuts . . . tighten the nuts.

3. Place saw in upright position.

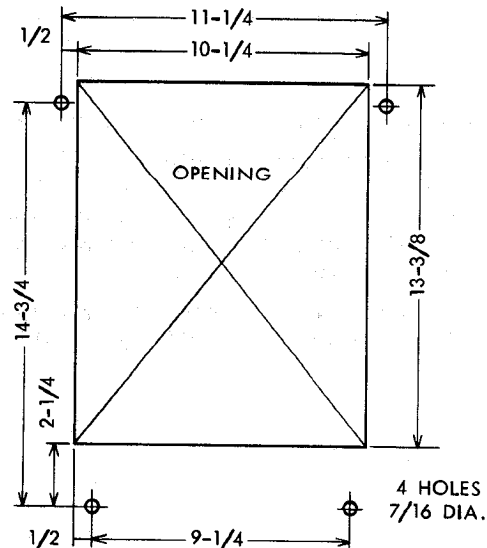
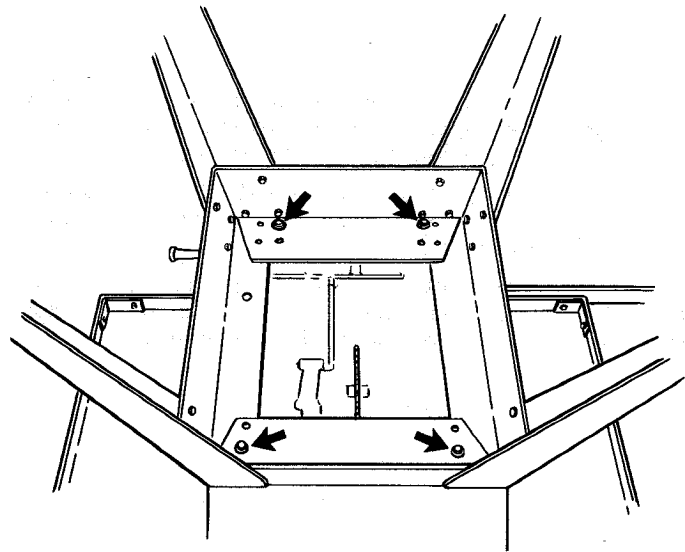

NOTE: All dimensions in inches.

FRONT OF SAW

If you mount the saw on any other bench, make sure that there is an opening in the top of the bench the same size as the opening in the bottom of the saw so that the sawdust can drop through. Recommended working height is 33 to 37 in. from the top of the saw table to the floor.

ALIGNING TABLE EXTENSIONS

1. "Tap" extensions upwards or downwards, using a block of wood and a hammer until they are even with top of saw table. Be sure end of extensions are even with front edge of saw.
2. Tighten screws.

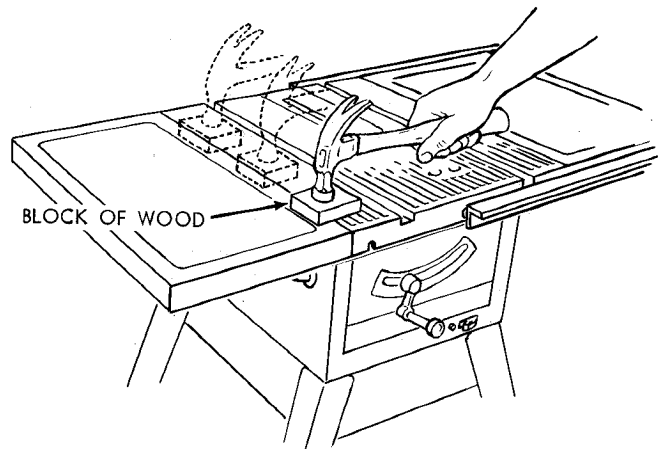

3. Lay a straight piece of wood or a framing square on table to act as a straightedge. If outer edge of extension is higher or lower than table surface:
 - A. Slightly loosen nuts holding bracket to extension using 7/16 in. wrench.
 - B. Move end of extension up or down until outer edge is even with table surface . . . check with GUIDE BAR . . . tighten nuts.
 - C. Recheck INNER edge of extension to make sure it has not moved . . . readjust, if necessary.
4. Replace three screws in rear of table extension on right side.

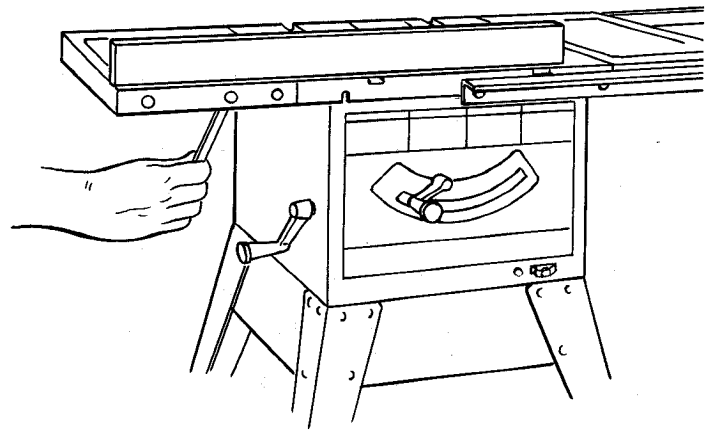

5. Hold rod with one hand and with a 7/16 in. wrench or pliers start screwing on ONE of the nuts only A TURN OR TWO . . . screw on other nut the same way. Using TWO 7/16 in. wrenches or pliers tighten both of the nuts.

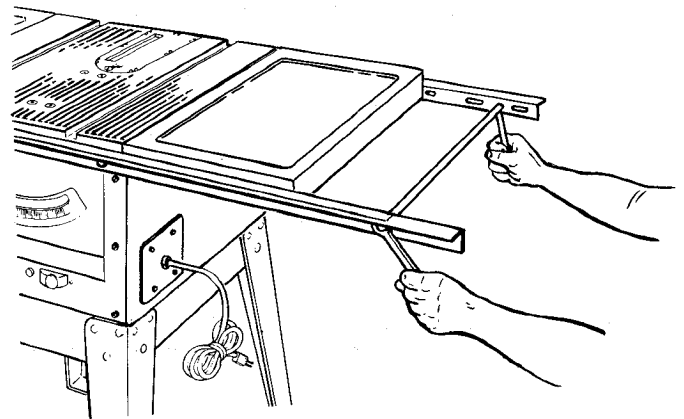

IMPORTANT: Apply a coat of paste wax to the top surface and front edge of the front guide bar. This will allow the fence to slide more easily.

ALIGNING RIP FENCE

6. Position rip fence over miter gauge groove, holding up the rear end while engaging front end with bar . . . lower fence onto table.

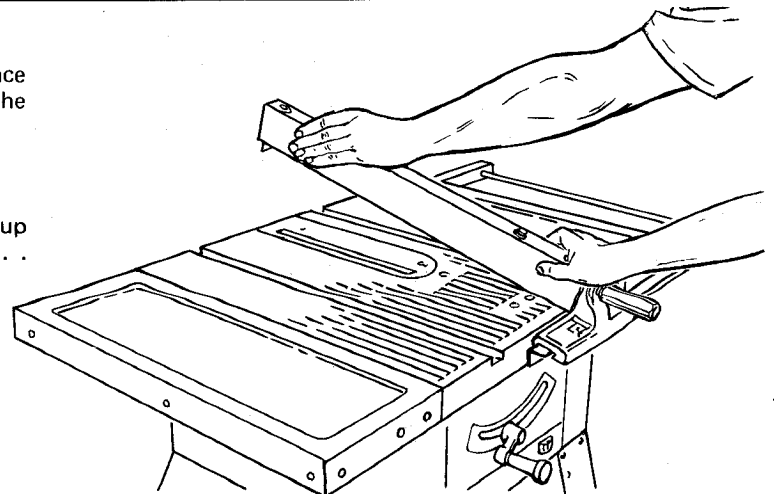

The rip fence must be PARALLEL with the sawblade and Miter Gauge grooves . . . Move fence until it is along side of groove. Do NOT LOCK IT. It should be parallel to groove. If it is not;

- A. Loosen the two "Hex. Head Screws."
- B. Hold fence head tightly against bar . . . move end of fence so that it is parallel with groove.
- C. Tighten handle.
- D. Alternately tighten the screws.

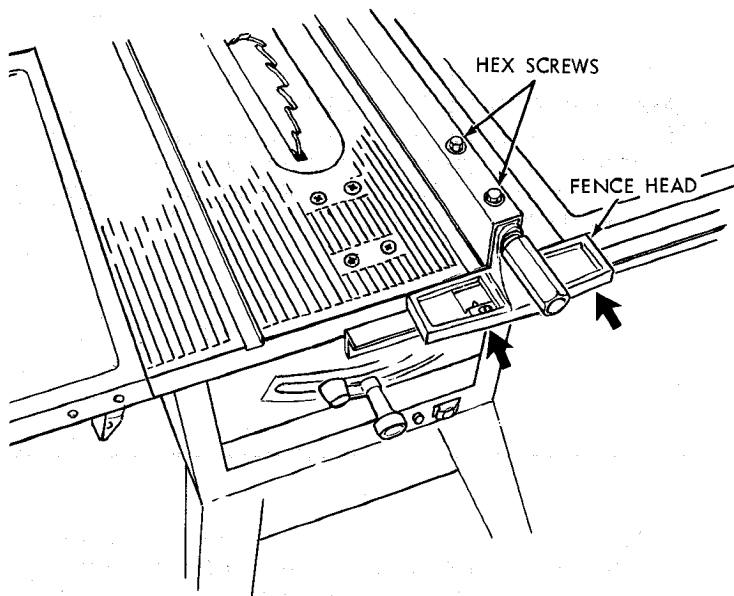

Place fence on saw but DO NOT LOCK IT. Move the REAR END of the fence slightly to the right or left . . . when you release it, the fence should "spring" back to its original position. If it does not, the spring pressure must be INCREASED.

1. Loosen the screws.
2. Move Spring slightly toward front of fence.

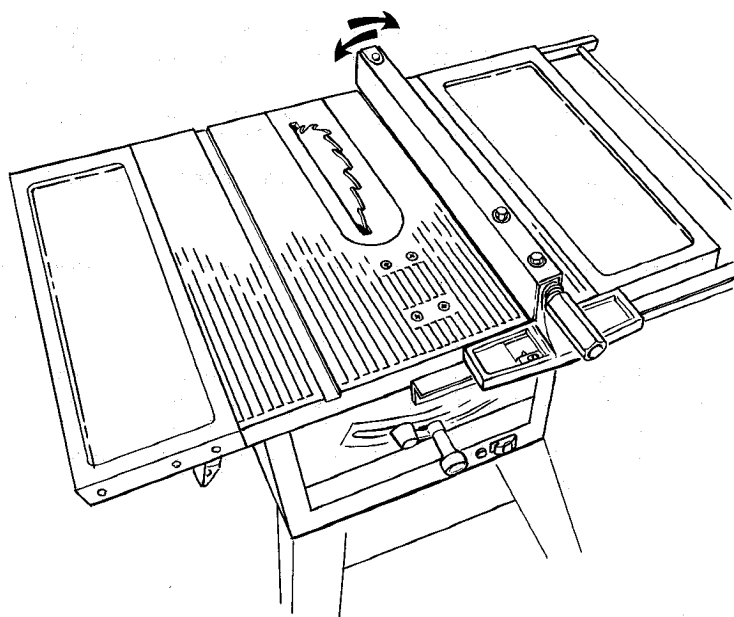

If the fence does not slide easily along the bars, the pressure of the spring can be REDUCED.

1. Loosen the screws.
2. Move spring slightly toward rear of fence . . . tighten screws.

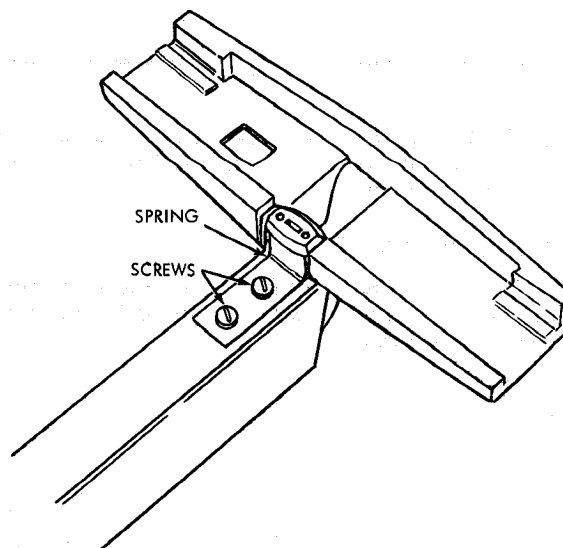

ADJUSTING RIP SCALE POINTER

1. Turn ELEVATION crank counterclockwise until blade is up as high as it will go.

IMPORTANT: BLADE must be SQUARE (90°) to TABLE, in order to ALIGN rip fence.

2. Position fence on right side of sawblade so that it touches the sides of the teeth . . . tighten lock handle.
3. Loosen screw holding the pointer . . . adjust pointer so that it points to "0" . . . tighten screw.

NOTE: If you cannot adjust pointer so that it points to "0", loosen the screws holding the front guide bar and move the guide bar.

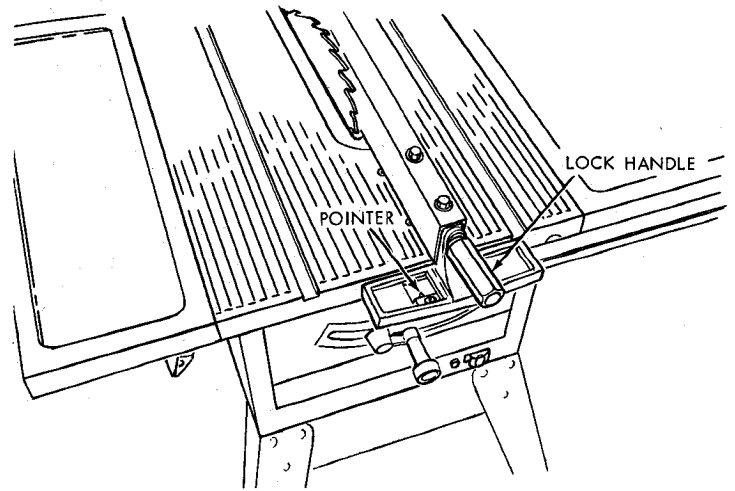

INSTALLING BLADE GUARD

1. From among the loose parts, find the hardware as shown.

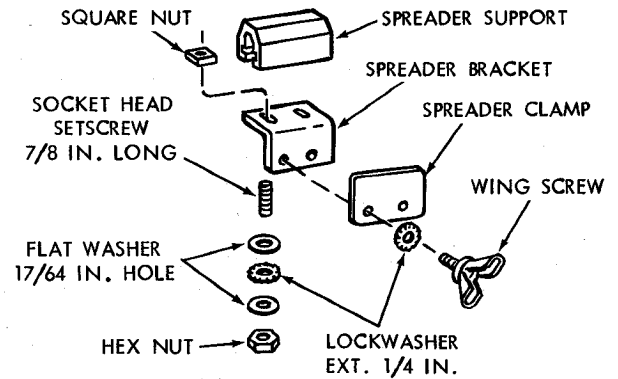

2. MAKE SURE THE BLADE IS ALL THE WAY UP AND SQUARE WITH THE TABLE.
3. Position SPREADER SUPPORT on rod until it is even with the end of the rod.

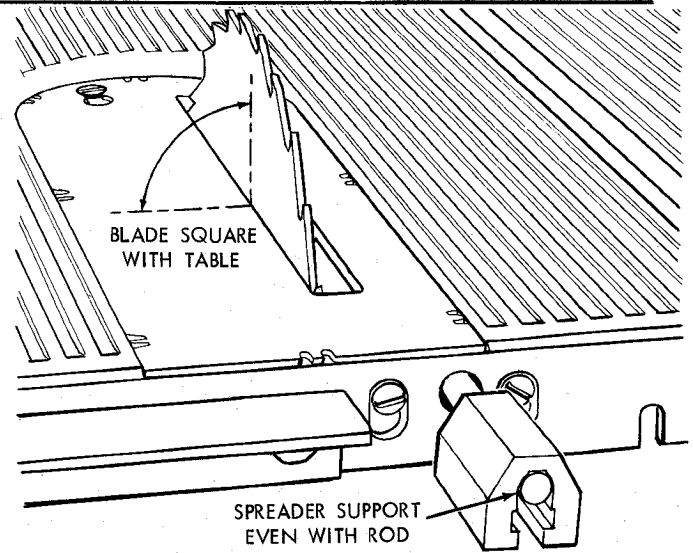

4. Assemble the 7/8 in. long setscrews, nuts, lockwashers and washers to the SPREADER SUPPORT BRACKET and slip the nuts into the slot in the spreader support.
5. Finger tighten ONLY THE HEX NUTS.

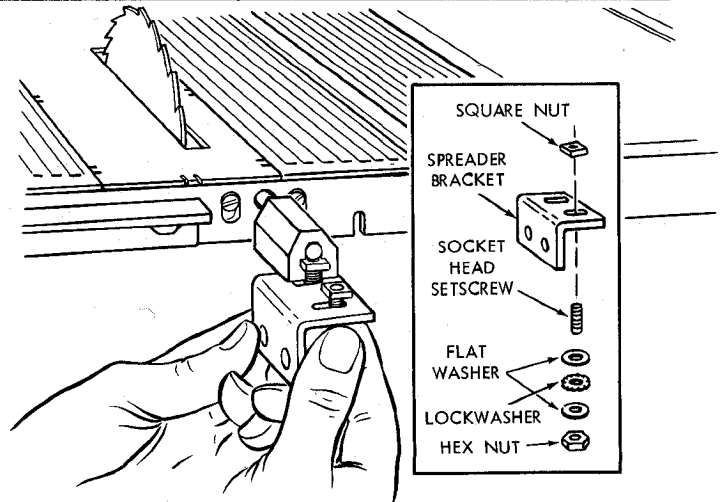

6. Lay a piece of flat straight wood and a square on saw table and rotate the SPREADER SUPPORT until the bracket is aligned with square.
7. MAKE SURE END OF SUPPORT, BRACKET AND ROD ARE EVEN . . . using an 1/8 in. setscrew wrench, TIGHTEN THE SET SCREWS ONLY.

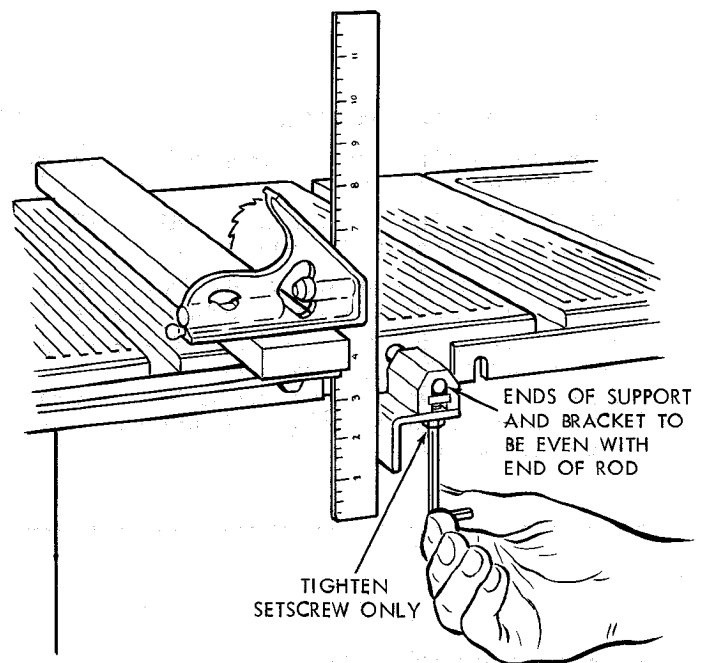

IMPORTANT: The SPREADER must always be PARALLEL to the sawblade and in the MIDDLE of the cut (KERF) made by the sawblade.

NOTE: The spreader is thinner than the width of the KERF by approximately six thicknesses of paper.

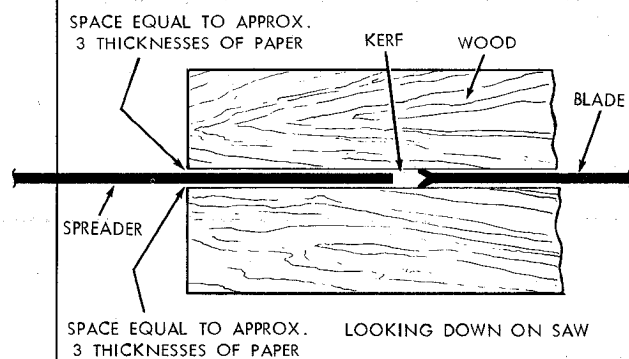

8. Make two folds in a small piece (6 x 6 in.) of ordinary NEWSPAPER making three thicknesses. The folded paper will be used as a "spacing gauge".

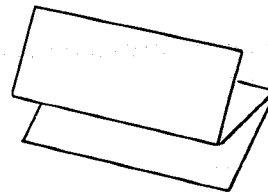

9. Install the SPREADER CLAMP. Place spreader between spreader clamp and bracket. Move forward until all three are in line. TIGHTEN WINGSCREWS.
10. Lift up both ANTI-KICKBACK PAWLS . . . insert one of the setscrew wrenches or a pencil in the notches to hold the pawls out of the way.
11. Lay a piece of straight flat wood against the sawblade. Insert folded paper between spreader and strip of wood.
12. MAKE SURE THE HEX NUTS UNDERNEATH ARE LOOSE.
13. Hold the spreader tightly against the wood and make sure the wood is against the saw blade. TIGHTEN THE HEX NUTS.
This will align the spreader in the middle of the cut (KERF) made by sawblade.

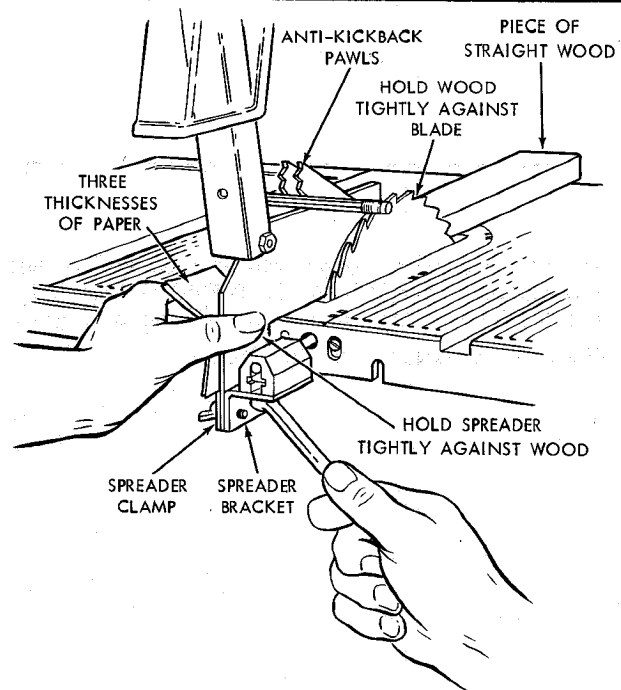

GETTING TO KNOW YOUR SAW

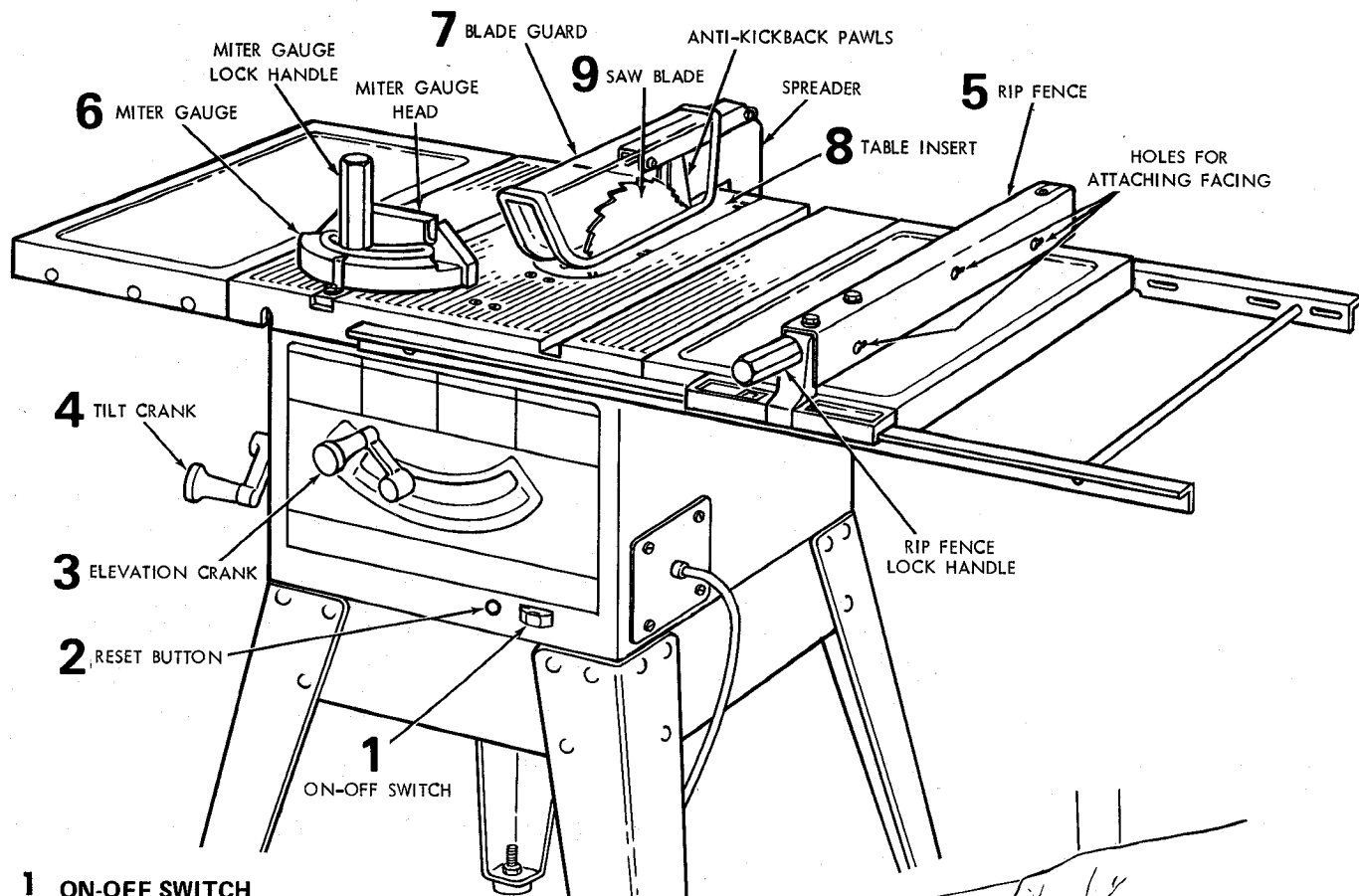

1 ON-OFF SWITCH

CAUTION: Before turning switch on, make sure the blade guard is correctly installed and operating properly.

The On-Off Switch has a locking feature. THIS SHOULD PREVENT UNAUTHORIZED AND POSSIBLY HAZARDOUS USE BY CHILDREN AND OTHERS.

- A. Insert key into switch.
- B. TO turn saw ON ... stand to either side of the blade never in line with it ... insert finger under switch lever and pull END of lever out. After turning switch ON, always allow the blade to come up to full speed before cutting. Do not cycle the motor switch on and off rapidly, as this may cause the sawblade to loosen. In the event this should ever occur, allow the sawblade to come to a complete stop and retighten the arbor nut normally, not excessively. Never leave the saw while the power is "ON".
- C. TO turn saw OFF ... PUSH lever in. Never leave the saw until the cutting tool has come to a complete stop.
- D. TO lock switch in OFF position ... hold switch IN with one hand ... REMOVE key with other hand.

WARNING: FOR YOUR OWN SAFETY, LOWER BLADE OR OTHER CUTTING TOOL BELOW TABLE SURFACE. (IF BLADE IS TILTED, RETURN IT TO VERTICAL (90°) POSITION). ALWAYS LOCK THE SWITCH "OFF". WHEN SAW IS NOT IN USE ... REMOVE KEY AND KEEP IT IN A SAFE PLACE ... ALSO ... IN THE EVENT OF A POWER FAILURE (ALL OF YOUR LIGHTS GO OUT) TURN SWITCH OFF ... LOCK IT AND REMOVE THE KEY. THIS WILL PREVENT THE SAW FROM STARTING UP AGAIN WHEN THE POWER COMES BACK ON.

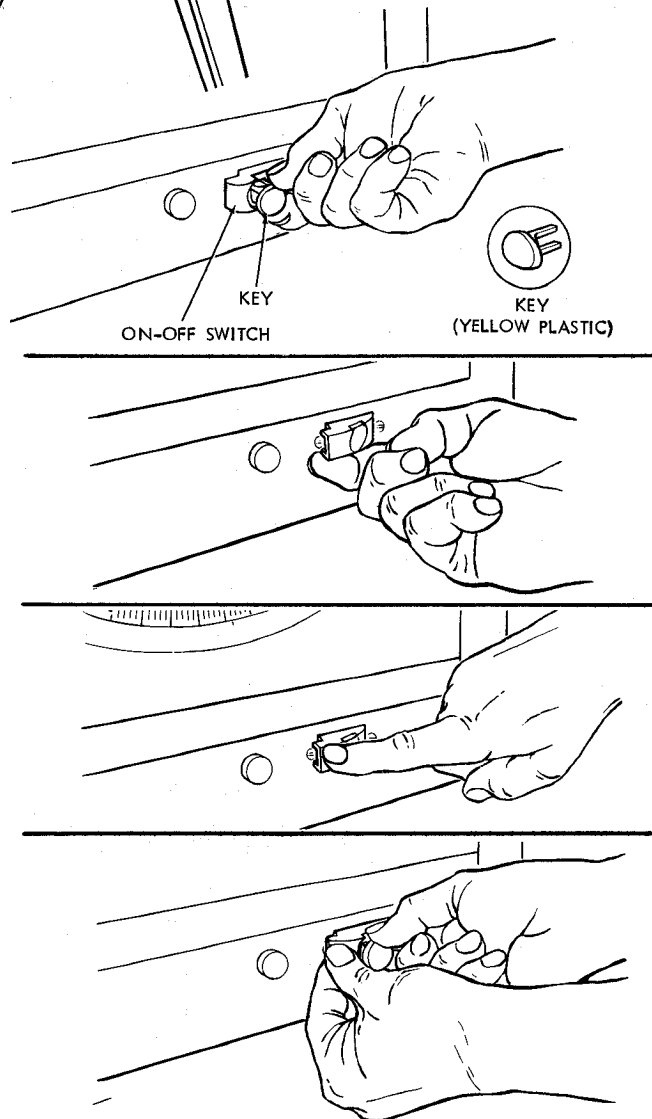

2 RESET BUTTON ... See "Motor Specifications and Electrical Requirements" section, "Motor Safety Protection."

3 ELEVATION CRANK ... elevates or lowers the blade. Turn counterclockwise to elevate ... clockwise to lower.

NOTE: WHEN THE BLADE IS TILTED TO 45°, IT CANNOT BE LOWERED ALL THE WAY BELOW THE TABLE. IT WILL PROJECT APPROX. 1/2 IN.

4 TILT CRANK ... tilts the blade for bevel cutting. Turn clockwise to tilt toward left ... counterclockwise to tilt toward right.

When the blade is tilted to the LEFT as far as it will go, it should be at 45° to the table and the bevel pointer should point 45°.

NOTE: There are LIMIT STOPS inside the saw which prevent the blade from tilting beyond 45° to the LEFT and 90° to the RIGHT. (See "Adjustments" section "Blade Tilt, or Squareness of Blade to Table").

5 RIP FENCE ... is locked in place by tightening the lock handle. To move the fence, loosen the handle and grasp the fence with one hand at the front.

Holes are provided in the rip fence for attaching a wood facing when using the dado head, or molding head.

Select a piece of smooth straight wood approx. 3/4 in. thick and the same size as the rip fence.

Attach it to the fence with three Round Head #10 Wood Screws 2 in. long. To remove the facing, loosen the screws, slide the facing forward and pull the screws through the round holes.

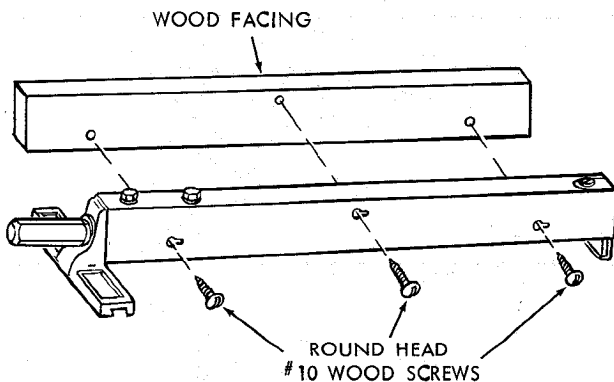

6 MITER GAUGE ... head is locked in position for crosscutting or mitering by tightening the lock handle. ALWAYS LOCK IT SECURELY WHEN IN USE.

Notches are provided in the miter gauge for attaching an AUXILIARY FACING to make it easier to cut long pieces. Be positive facing does not interfere with the proper operation of the sawblade guard.

Select a suitable piece of smooth straight wood ... drill two holes through it and attach it with screws.

NOTE: When bevel crosscutting, attach facing so that it extends to the right of the miter gauge and use the miter gauge in the groove to the right of the blade.

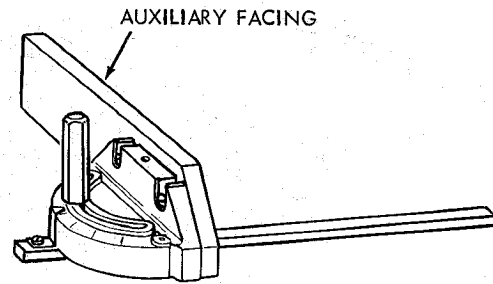

7 BLADEGUARD must always be in place and working properly for all thru-sawing cuts. That is, all cuts whereby the blade cuts completely through the workpiece.

To remove the guard for special operations, loosen the wingscrews and move spreader away from saw and lift upwards. DO NOT DISTURB THE SETTING OF THE HEX. HEAD SCREWS.

When replacing the guard, make sure the spreader is moved toward front of saw so that wingscrews are at end of slots. TIGHTEN THE WINGSCREWS SECURELY.

8 TABLE INSERT is removable for removing or installing blades or other cutting tools . . .

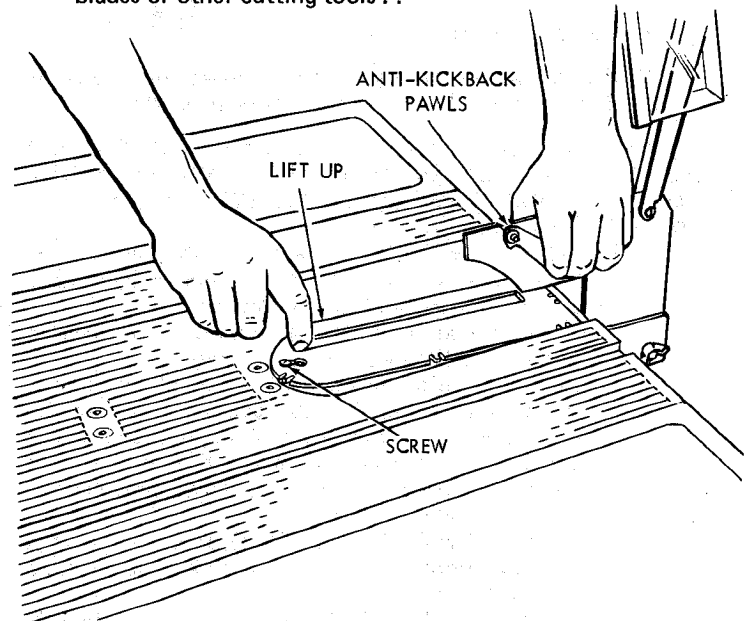

WARNING: FOR YOUR OWN SAFETY, TURN SWITCH "OFF" AND REMOVE PLUG FROM POWER SOURCE OUTLET BEFORE REMOVING INSERT.

- Lower the blade below the table surface.
- Loosen screw.
- Lift anti-kickback pawls.
- Lift insert from front end, and pull toward front of saw.

NEVER OPERATE THE SAW WITHOUT THE PROPER INSERT IN PLACE. USE THE SAW BLADE INSERT WHEN SAWING ... USE THE COMBINATION DADO MOLDING INSERT WHEN DADOING OR MOLDING.

REMOVING AND INSTALLING SAWBLADE

WARNING: FOR YOUR OWN SAFETY, TURN SWITCH "OFF" AND REMOVE PLUG FROM POWER SOURCE OUTLET BEFORE REMOVING OR INSTALLING SAWBLADE.

- A. Remove insert.
- B. Place ARBOR wrench on flat surfaces of saw ARBOR . . . ARBOR NUT wrench on nut . . . position wrenches as shown . . . hold your hands well above blade.
- C. With ARBOR wrench against table, PULL ARBOR NUT wrench FORWARD to LOOSEN nut.
- D. To TIGHTEN nut . . . HOLD ARBOR wrench against rear of table . . . PUSH ARBOR NUT wrench toward rear.

NOTE: When installing the blade . . . make sure the teeth are pointing toward the front of the saw . . . and that the blade and collars are clean, and free from any burrs.

The HOLLOW side of the collars must be against the blade.

Always tighten the arbor nut securely.

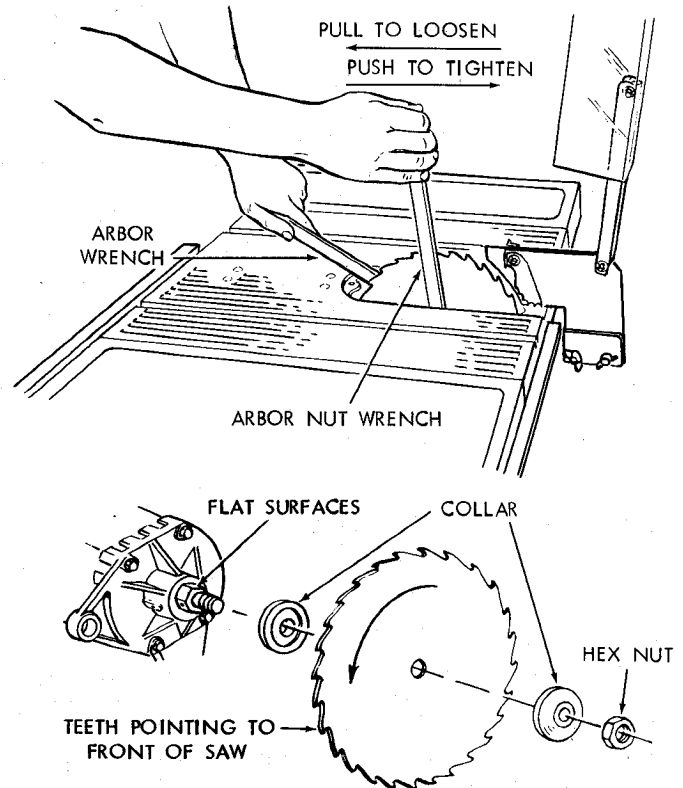

BASIC SAW OPERATION

USING THE MITER GAUGE

CROSSCUTTING, MITER CUTTING, BEVEL CUTTING, COMPOUND MITER CUTTING and when **RABBETING** across the end of narrow workpiece, **THE MITER GAUGE IS USED.**

WARNING: FOR YOUR OWN SAFETY, ALWAYS OBSERVE THE FOLLOWING SAFETY PRECAUTIONS IN ADDITION TO THE SAFETY INSTRUCTIONS ON PAGES 2,3, and 4.

1. Never make these cuts freehand (without using the miter gauge or other auxiliary devices) because the blade could bind in the cut and cause a KICKBACK or cause your fingers or hand to slip into the blade.
2. Always lock the miter gauge securely when in use.
3. Remove rip fence from table.
4. Make sure blade guard is installed for all "THRU-SAWING" operations (when sawblade cuts entirely thru the thickness of the workpiece.) Replace guard IMMEDIATELY after completion of dadoing, molding or rabbeting cuts.
5. Have blade extend approximately 1/8 in. above top of workpiece. Additional blade exposure would increase the hazard potential.
6. Do not stand directly in front of the blade in case of a THROWBACK (Small cut-off piece caught by the back of the blade and thrown toward the operator). Stand to either side of the blade.
7. Keep your hands clear of the blade and out of the path of the blade.

8. If blade stalls or stops while cutting, TURN SWITCH OFF before attempting to free the blade.
9. Do not reach over or behind the blade to pull the workpiece through the cut . . . to support long or heavy workpieces . . . to remove cut-off pieces of material or FOR ANY OTHER REASON.
10. Do not pick up small pieces of cut-off material from the table. REMOVE them by pushing them OFF the table with a long stick. Otherwise they could be thrown back at you by the rear of the blade.
11. Do not remove small pieces of cut-off material that may become TRAPPED inside the blade guard while the saw is RUNNING. THIS COULD ENDANGER YOUR HANDS or cause a KICKBACK.

Turn the saw OFF. After the blade has stopped turning, lift the guard and remove the piece.

WORK HELPERS

Before cutting any wood on your saw, study all of the "Basic Saw Operations".

Notice that in order to make some of the cuts, it is necessary to use certain devices "Work Helpers" like the Push Stick, the Push Block and the Auxiliary Fence which you can make yourself.

After you have made a few practice cuts, make up these "helpers" before starting any projects. Make the "Push Stick" first. To rip the piece for the push stick, start out with a wide board, say 11-1/2 in. wide and set the rip fence 9-3/4 in. from the blade.

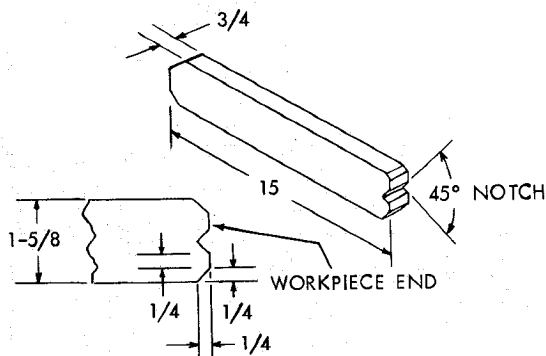

NOTE: All dimensions in inches

PUSH STICK

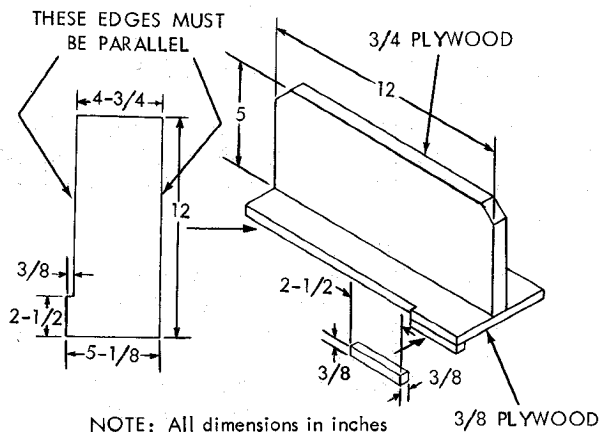

NOTE: All dimensions in inches

PUSH BLOCK

PUSH STICK AND PUSH BLOCK

Make the Push Stick using a piece of 1 x 2.

Make the Push Block using a piece of 3/8 in. and 3/4 in. plywood.

The small piece of wood 3/8 in. x 3/8 in. x 2-1/2 in. should be **GLUED** to the plywood . . . **DO NOT USE NAILS**. This is to prevent dulling the sawblade in the event you mistakenly cut into the push block.

Position the handle in the center of the plywood and fasten together with glue and woodscrews.

AUXILIARY FENCE

Make one using a piece of 3/8 in. and 3/4 in. plywood. Fasten together with glue and woodscrews.

NOTE: Since the Push Block is used with the Auxiliary Fence, the 4-3/4 in. dimensions must be held identical on both the pieces.

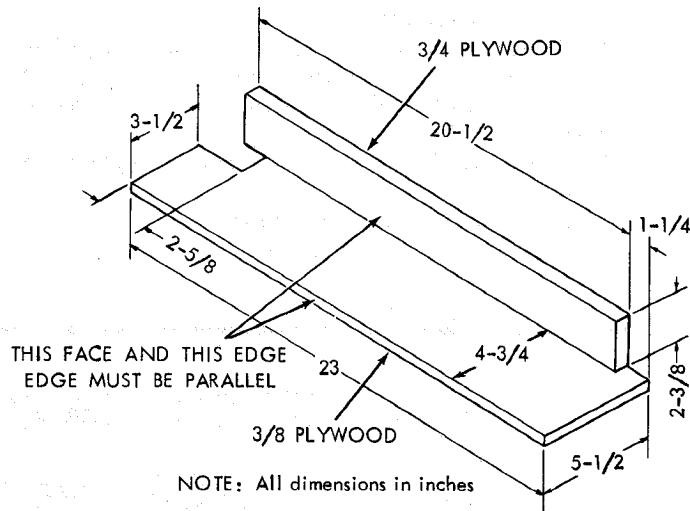

NOTE: All dimensions in inches

AUXILIARY FENCE

CROSSCUTTING

CROSSCUTTING is known as cutting wood across the grain, at 90°, or square with both the edge and the flat side of the wood. This is done with miter gauge set at "0".

The graduations on the miter gauge provide accuracy for average woodworking. In some cases where extreme accuracy is required, when making angle cuts, for example, make a trial cut and then recheck it with an accurate square, or protractor.

If necessary, the miter gauge head can be swiveled slightly to compensate for any inaccuracy.

NOTE: The space between the miter gauge bar and the groove in the table is held to a minimum during manufacturing.

For maximum accuracy when using the miter gauge, always "favor" one side of the groove in the table. In other words, don't move the miter gauge from side to side while cutting, but keep one side of the bar riding against one side of the groove.

NOTE: Glue a piece of sandpaper to the face of the miter gauge head. This will help prevent the workpiece from "creeping" while it is being cut.

The Hold-Down Clamp (Optional Accessory) should be used on the miter gauge for greater accuracy.

The miter gauge may be used in either of the grooves in the table. Make sure it is locked.

When using the miter gauge in the **LEFT** hand groove, hold the workpiece firmly against the miter gauge head with your left hand, and grip the lock knob with your right.

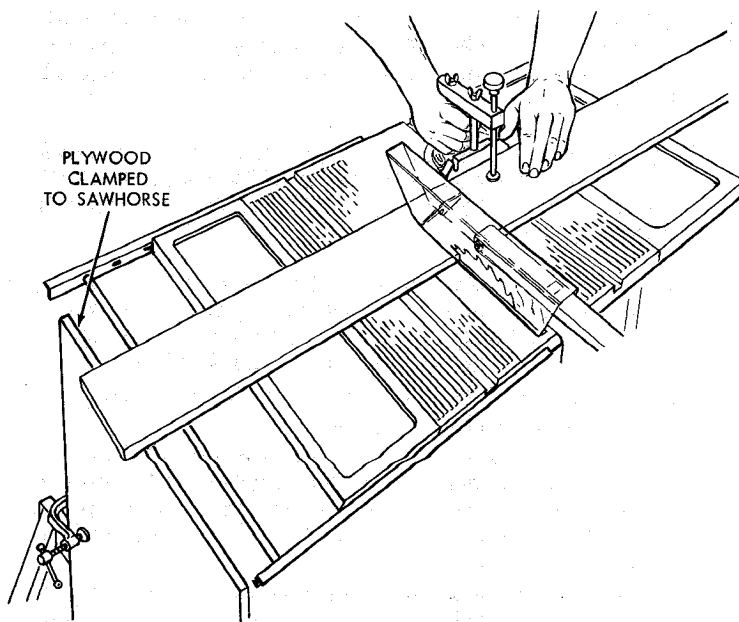

When using the **RIGHT** hand groove, hold the workpiece with your right hand and the lock knob with your left hand.

When crosscutting a long board, make sure that it is supported.

You can make a simple support by clamping a piece of plywood to a sawhorse.

When cutting long workpieces, you can also invert the AUXILIARY FENCE/WORK SUPPORT and position it on top of the guide bars to support the workpiece as near to the end as possible.

Use the Hold-Down Clamp (Optional Accessory) on the miter gauge for greater accuracy.

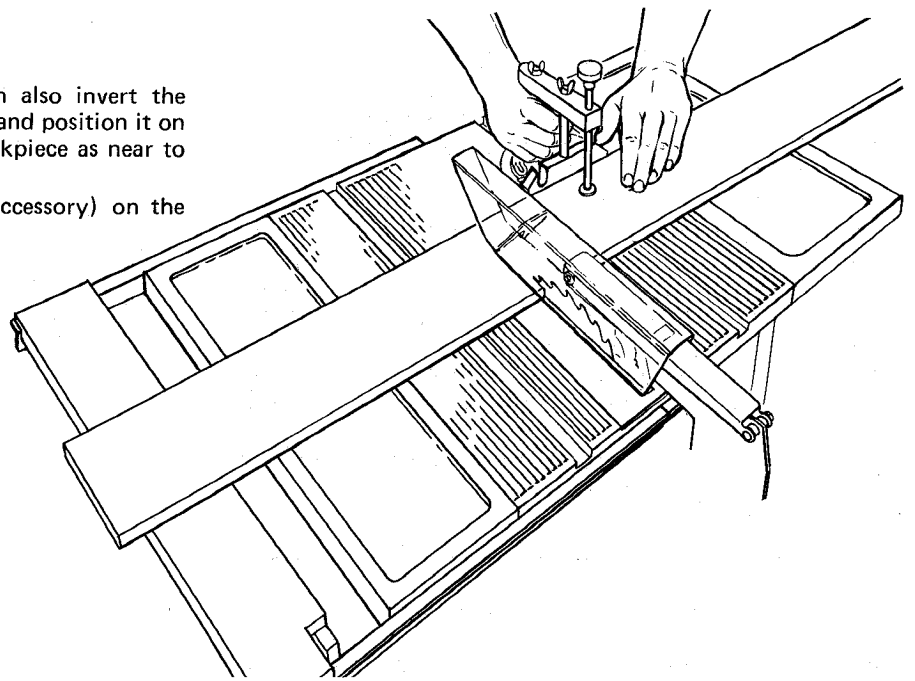

REPETITIVE CUTTING

REPETITIVE CUTTING is known as cutting a quantity of pieces the same length without having to mark each piece.

1. Use the Stop Rods (optional accessory) only for cutting duplicate pieces 6 in. long and longer.
2. **DO NOT FEED** workpiece with RIGHT hand, merely guide it, making sure that it does not bind or pinch the sawblade.

When making repetitive cuts from a long workpiece, make sure it is supported.

The Adjustable Table Extension (Optional Accessory) is recommended . . . or you can make a simple support by clamping a piece of plywood to a sawhorse.

Use the Hold-Down Clamp (Optional Accessory) on the miter gauge for greater accuracy.

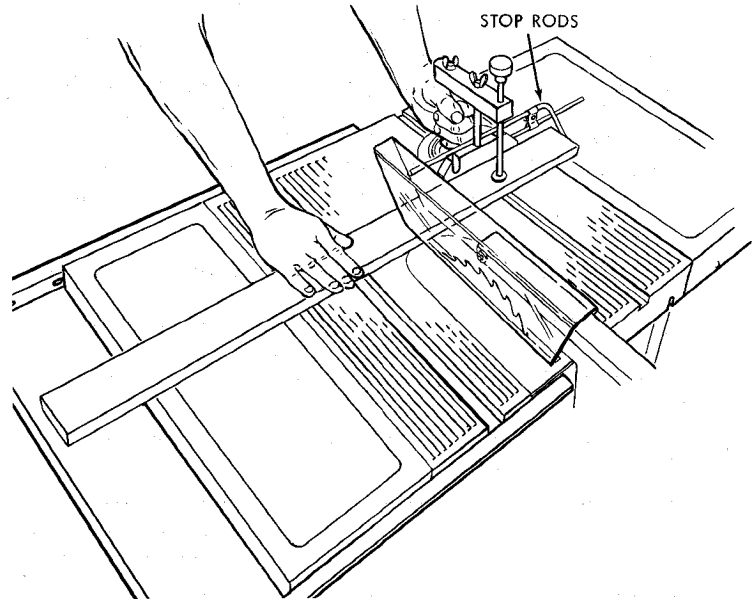

1. **NEVER USE THE RIP FENCE AS A LENGTH STOP BECAUSE THE CUTOFF PIECE COULD BIND BETWEEN THE FENCE AND THE BLADE CAUSING A KICKBACK.**

2. When making repetitive cuts shorter than 6 in., clamp a block of wood 3 in. long to the table to act as a length stop.

CAUTION: When clamping the block, make sure that the end of the block is well in front of the sawblade. Be sure it is clamped securely.

3. Slide the workpiece along the miter gauge until it touches the block . . . hold it securely or clamp it with the Hold-Down Clamp (Optional Accessory).
4. Make the cut . . . pull the workpiece back . . . push the cut off piece off the table with a long push stick . . . **DO NOT ATTEMPT TO PICK IT UP AS THIS COULD ENDANGER YOUR HANDS.**

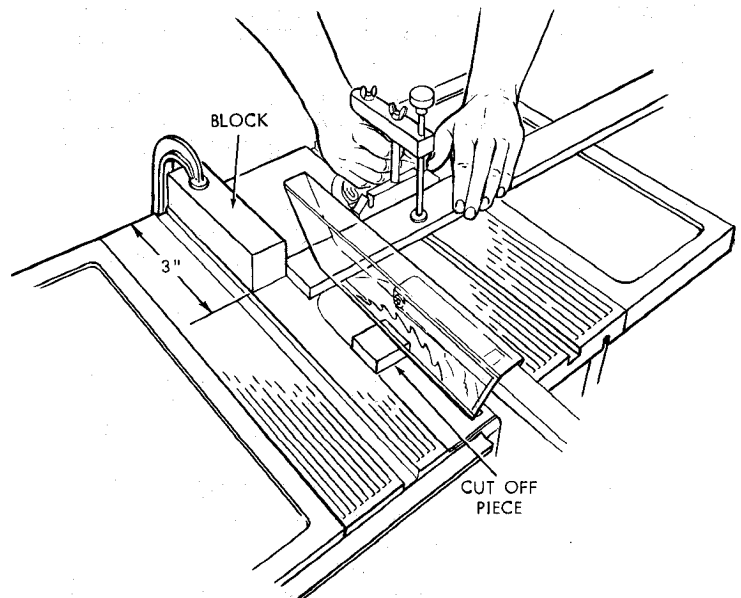

MITER CUTTING

MITER CUTTING is known as cutting wood at an angle other than 90° with the edge of the wood. Follow the same procedure as you would for crosscutting.

Adjust the miter gauge to the desired angle, and lock it.

The miter gauge may be used in either of the grooves in the table.

When using the miter gauge in the LEFT hand groove, hold the workpiece firmly against the miter gauge head with your left hand, and grip the lock handle with your right.

When using the RIGHT hand groove, hold the workpiece with your right hand and the lockhandle with your left hand.

Use the Hold-Down Clamp (Optional Accessory) on the miter gauge for greater accuracy.

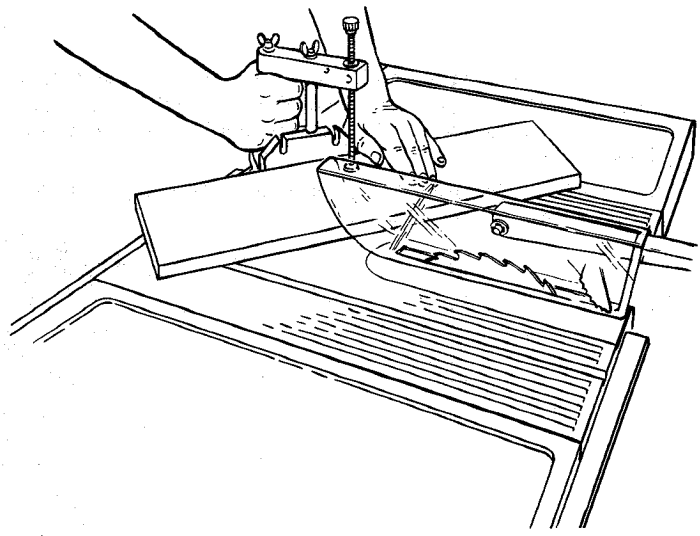

BEVEL CROSSCUTTING

BEVEL CROSSCUTTING is the same as crosscutting except that the wood is also cut at an angle . . . other than 90° with the flat side of the wood.

Adjust the blade to the desired angle.

Use the Miter Gauge in the groove to the RIGHT of the blade. It cannot be used in the groove to the left because the blade guard will interfere. Hold the workpiece with your right hand and the lockhandle with your left hand.

Use the Hold-Down Clamp (Optional Accessory) on the miter gauge for greater accuracy.

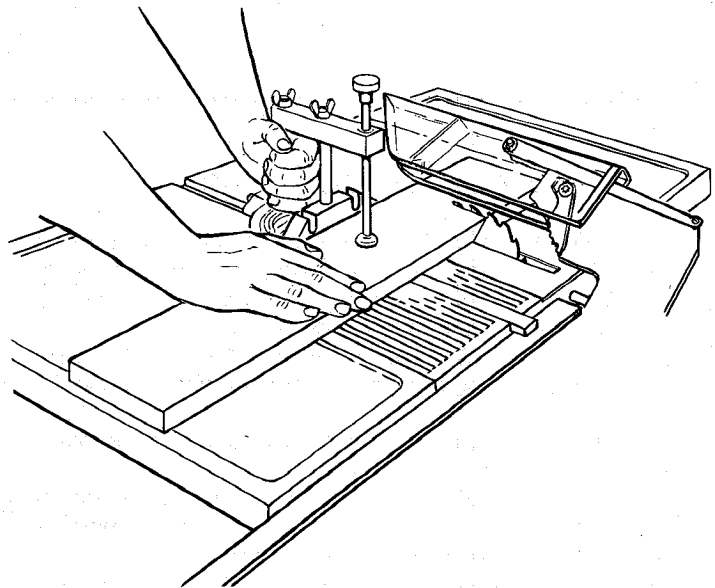

COMPOUND MITER CUTTING

COMPOUND MITER CUTTING is a combination of miter cutting and bevel crosscutting. The cut is made at an angle other than 90° to both the edge and the flat side of the wood.

Adjust the miter gauge and the blade to the desired angle . . .
. Make sure miter gauge is locked.

USING THE RIP FENCE

RIPPING, BEVEL RIPPING, RESAWING AND RABBETING are performed using the RIP FENCE together with the AUXILIARY FENCE, PUSH STICK OR PUSH BLOCK.

WARNING: FOR YOUR OWN SAFETY, ALWAYS OBSERVE THE FOLLOWING SAFETY PRECAUTIONS IN ADDITION TO THE SAFETY INSTRUCTIONS ON PAGES 2, 3, and 4.

1. Never make these cuts FREEHAND (without using the rip fence or auxiliary devices when required) because the blade could bind in the cut and cause a KICKBACK.
2. Always lock the rip fence securely when in use.
3. Remove miter gauge from table.
4. Make sure blade guard is installed for all thru-sawing type cuts. Replace the guard IMMEDIATELY following completion of resawing, rabbeting, dadoing, or molding operations.

Frequently check the action of the ANTI-KICKBACK PAWLS by passing the workpiece alongside of the spreader while saw is OFF.

Pull the workpiece TOWARD you. If the PAWLS do not DIG into the workpiece and HOLD it . . . the pawls must be REPLACED. See "Maintenance" section.

5. Have blade extend approximately 1/8 in. above top of workpiece. Additional blade exposure would increase the hazard potential.
6. Do not stand directly in front of the blade in case of a KICKBACK. Stand to either side of the blade.
7. Keep your hands clear of the blade and out of the path of the blade.
8. If the blade stalls or stops while cutting, TURN SWITCH OFF before attempting to free the blade.
9. Do not reach over or behind the blade to pull the workpiece through the cut . . . to support long or heavy workpieces . . . to remove small cut-off pieces of material or FOR ANY OTHER REASON.
10. Do not pick up small pieces of cut-off material from the table. REMOVE them by pushing them OFF the table with a long stick. Otherwise they could be thrown back at you by the rear of the blade.
11. Do not remove small pieces of cut-off material that may become TRAPPED inside the blade guard while the saw is RUNNING. THIS COULD ENDANGER YOUR HANDS or cause a KICKBACK.

Turn the saw OFF. After the blade has stopped turning, lift the guard and remove the piece.

RIPPING

RIPPING is know as cutting a piece of wood with the grain, or lengthwise. This is done using the rip fence. Position the fence to the desired **WIDTH OF RIP** and lock in place.

Before starting to rip, be sure

- A. Rip Fence is parallel to sawblade.
- B. Spreader is properly aligned with sawblade.
- C. Anti-Kickback pawls are functioning properly.

When ripping **LONG BOARDS** or **LARGE PANELS**, always use a work support.

A simple one can be made by clamping a piece of plywood to a sawhorse.

ALWAYS SUPPORT LONG WORKPIECES

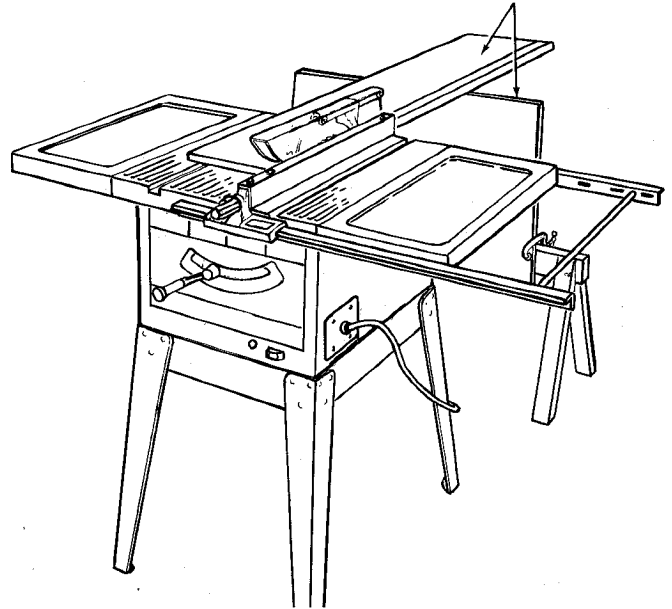

BEVEL RIPPING

When bevel ripping material 6 in. or narrower, use fence on the right side of the blade **ONLY**. This will provide more space between the fence and the sawblade for use of a push stick. If the fence is mounted to the left, the sawblade guard may interfere with proper use of a push stick.

When "WIDTH OF RIP" is 6 in. and **WIDER** use your **RIGHT** hand to feed the workpiece until it is clear of the table.

Use **LEFT** hand **ONLY** to guide the workpiece . . . do not **FEED** the workpiece with the left hand.

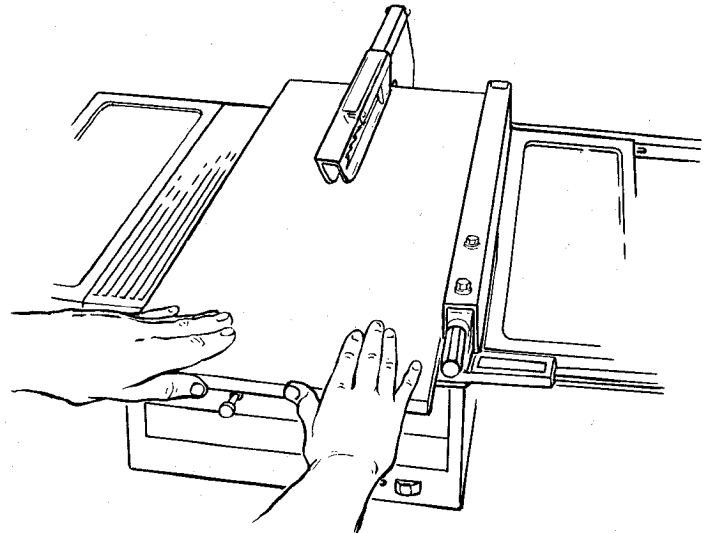

When "WIDTH OF RIP" is 2 in. to 6 in. wide **USE THE PUSH STICK** to feed the work.

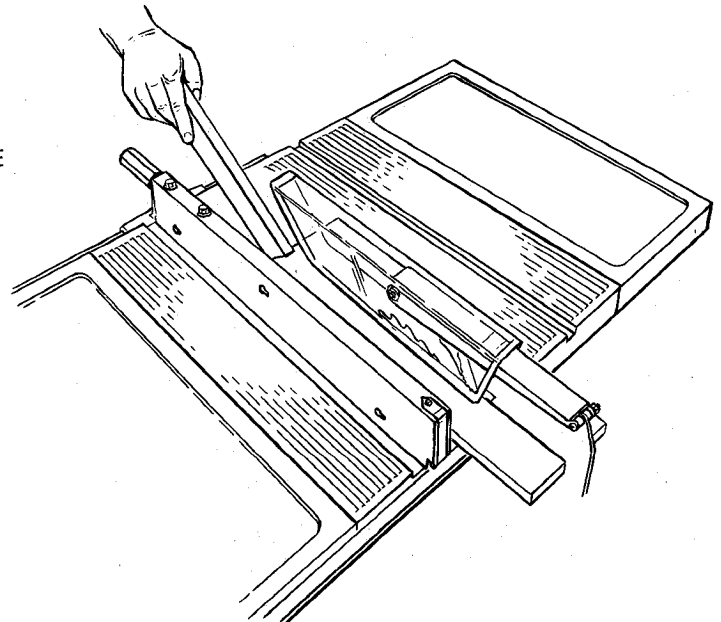

When WIDTH OF RIP is NARROWER than 2 in., the push stick CANNOT be used because the guard will interfere . . . USE the AUXILIARY FENCE and PUSH BLOCK.

Attach auxiliary fence to rip fence with two "C" clamps. Feed the workpiece by hand until the end is approx. 1 in. from the front edge of the table. Continue to feed using the PUSH BLOCK.

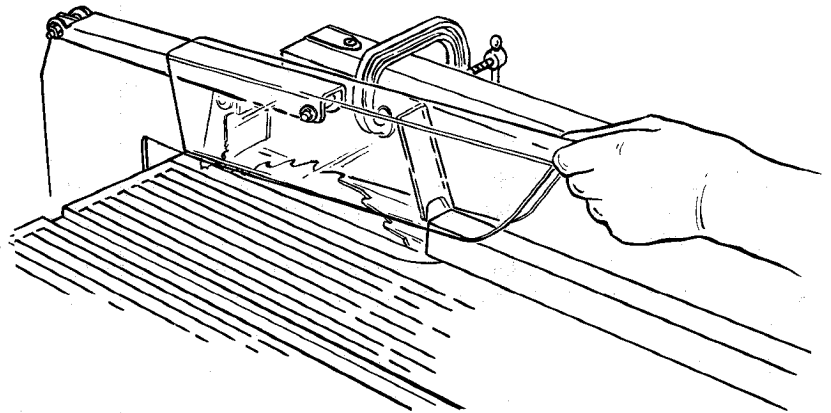
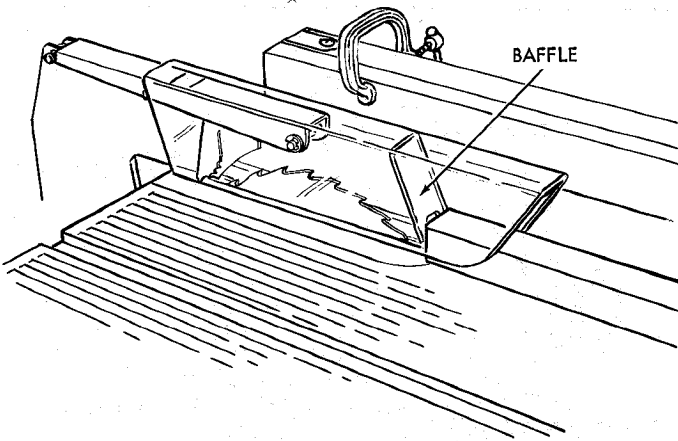
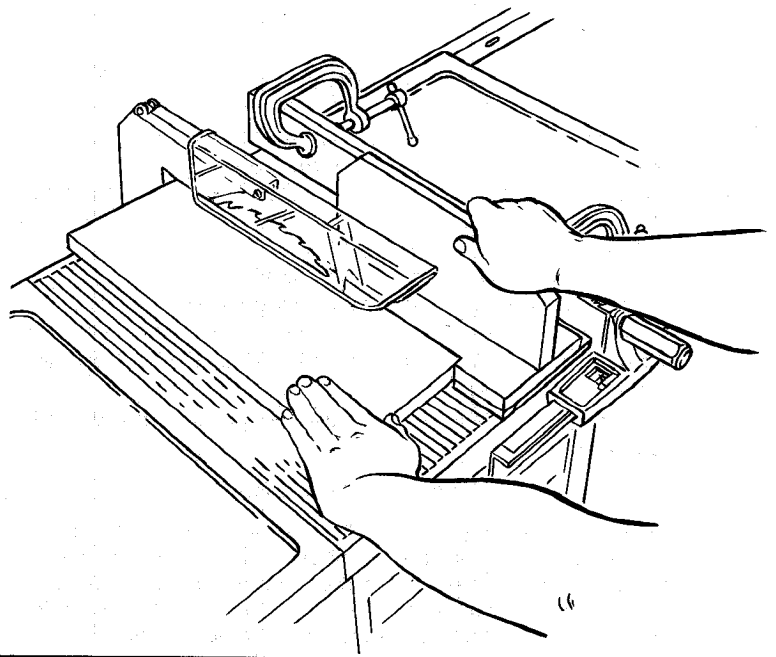

When ripping narrow strips that may enter the guard and strike the baffle, CAREFULLY raise guard only enough to clear the workpiece. Use Push Block to complete cut.

RESAWING

RESAWING is known as ripping a piece of wood through its thickness. NOTE: to RESAW a piece of wood wider than 2 in. . . it will be necessary to remove the blade guard . . . and use the AUXILIARY FENCE (See Page 18)

Do not attempt to resaw BOWED or WARPED material.

Clamp it to the table so that the workpiece will SLIDE EASILY but not TILT or MOVE SIDeways without BINDING between the two fences.

Do not clamp directly to the bottom edge of the table because the "swivel" of the clamps will not grip properly. Place a small block of wood between the bottom edge of the table and the "C" clamps.

WARNING: FOR YOUR OWN SAFETY . . .

1. DO NOT "BACK UP" (REVERSE FEEDING) WHILE RESAWING BECAUSE THIS COULD CAUSE A KICKBACK.
2. INSTALL BLADE GUARD IMMEDIATELY UPON COMPLETION OF THE RESAWING OPERATION.

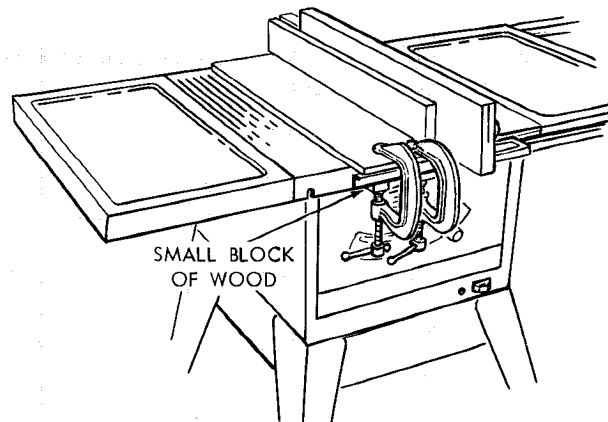

CUTTING PANELS

When cutting panels (whenever fence is positioned outside of table surface), ALWAYS use the AUXILIARY FENCE/WORK SUPPORT.

1. Unlock fence and raise rear end.
2. Position AUXILIARY FENCE as shown and attach it with two "C" clamps.

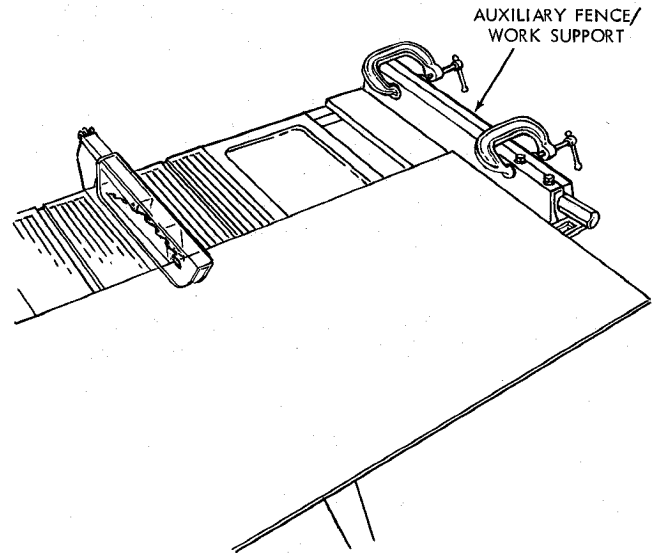

RABBETING

Rabbeting is known as cutting out a section of the corner of a piece of material.

To make a RABBET requires two cuts which do not go all the way through the material. Therefore the blade guard must be removed.

1. Remove blade guard.
2. Adjust rip fence and blade to required dimensions.
3. Make first cut through edge. Follow resawing procedure.
4. Remove auxiliary fence and make second cut.
5. INSTALL BLADE GUARD IMMEDIATELY UPON COMPLETION OF RABBETING OPERATION.

Rabbet cuts can also be made using the dado head or molding head.

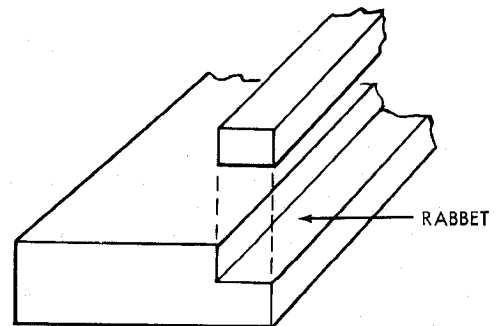

ADJUSTMENTS

WARNING: FOR YOUR OWN SAFETY, TURN SWITCH "OFF" AND REMOVE PLUG FROM POWER SOURCE OUTLET BEFORE MAKING ANY ADJUSTMENTS.

MITER GAUGE

NOTE: The graduations on the miter gauge provide accuracy for average woodworking. In some cases where extreme accuracy is required, when making angle cuts, for example, make a trial cut and then recheck it with an accurate square or protractor.

If necessary, the miter gauge head can be swiveled slightly to compensate for any inaccuracy.

The HEAD should be SQUARE (90°) with the bar when the pointer points to "0".

To check for squareness, place an accurate square on the miter gauge. If the head is NOT SQUARE with the bar:

1. Loosen the lock knob.
2. Position the head square with the bar . . . tighten the lock knob.

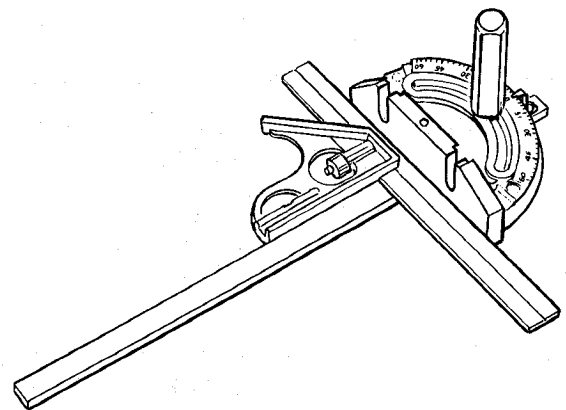

3. Loosen the screw and adjust the pointer, so it points to zero.

The swiveling movement of the head can be adjusted by tightening or loosening the set screw located in side of the head using the 1/8 in. setscrew wrench.

HEELING ADJUSTMENT or PARALLELISM OF SAWBLADE TO MITER GAUGE GROOVE

While cutting, the material must move in a straight line PARALLEL to the SAWBLADE . . . therefore both the miter gauge GROOVE and the RIP FENCE must be PARALLEL to the SAWBLADE.

If the sawblade IS NOT parallel to the miter gauge groove, the blade will bind at one end of the cut. (This is known as "HEELING").

To check for parallelism:

WARNING – FOR YOUR OWN SAFETY, TURN SWITCH "OFF" AND REMOVE PLUG FROM POWER SOURCE OUTLET.

1. Raise blade all the way up . . . raise blade guard.
2. Mark an "X" on one of the teeth which is SET (bent) to the LEFT.
3. Place the head of a combination square in the GROOVE . . . adjust blade of square so that it just touches the tip of the MARKED tooth.
4. Move square to REAR, rotate blade to see if MARKED tooth again touches blade of square.
5. If tooth touches square the same amount at FRONT and REAR . . . sawblade is PARALLEL to MITER GAUGE GROOVE.

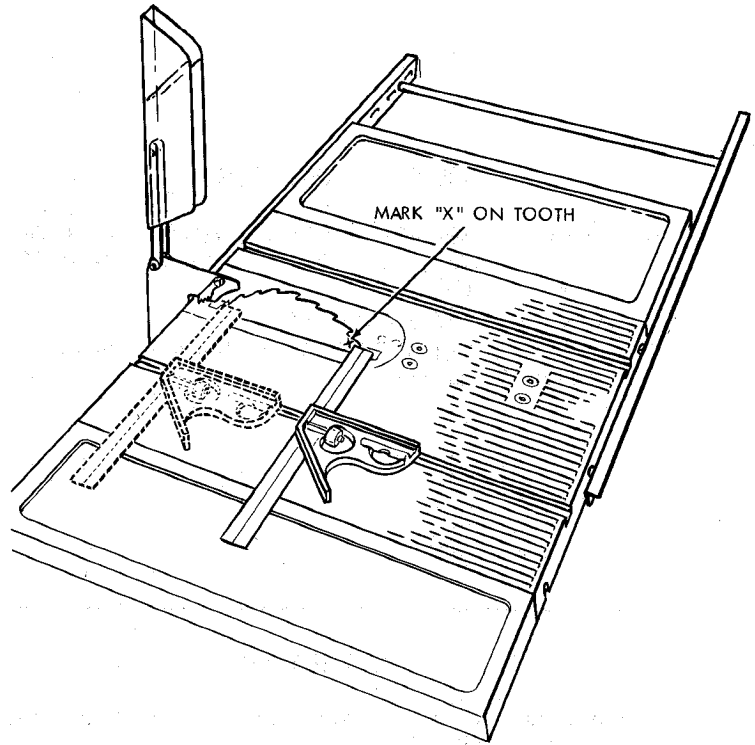

If tooth does not touch the same amount . . . the mechanism underneath must be adjusted to make the blade PARALLEL to GROOVE.

1. Loosen the 4 screws (about 1/4 to 1/2 turn) using 3/16 in. setscrew wrench furnished with saw.
This will allow the mechanism below the table to be shifted sideways.
 2. Fold a piece of cardboard or heavy paper over the blade to protect your hands.
 3. Grasp the blade and move it to the right or left a small amount and tighten one of the screws.
 4. Check with square to determine if MARKED TOOTH touches square the same amount at front and rear.
If it does, tighten other three screws. If it does not, loosen screw and move blade the required amount.
 5. Alternately tighten the screws slowly.
- NOTE:** Use the setscrew wrench as shown . . . do not use a pair of pliers or any other tool to gain more leverage on the setscrew wrench.

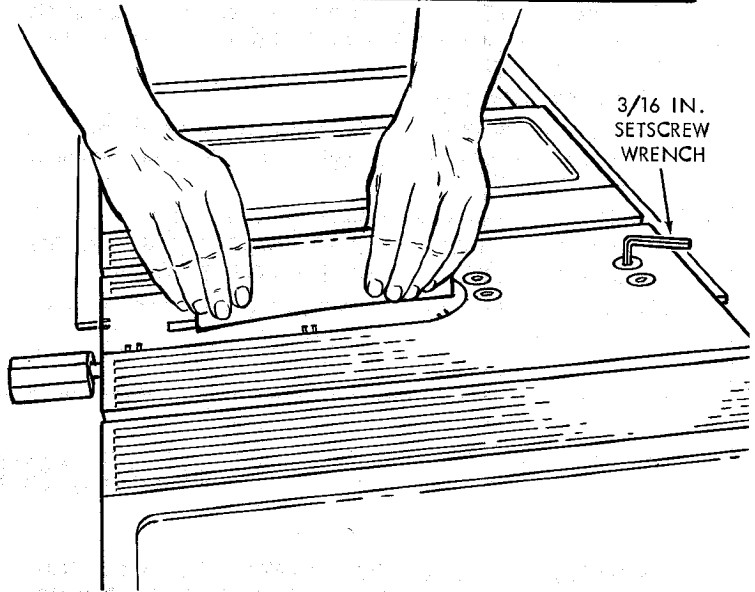

BLADE TILT, OR SQUARENESS OF BLADE TO TABLE

90° (SQUARE) and 45° (BEVEL) STOP COLLARS.

When the bevel pointer is pointing directly to the "0" mark on the bevel scale, the sawblade should make a SQUARE cut 90° to the table.

To check for SQUARENESS:

WARNING: FOR YOUR OWN SAFETY, TURN SWITCH "OFF" AND REMOVE PLUG FROM POWER SOURCE OUTLET.

1. Raise blade all the way UP . . . raise blade guard.
2. TILT blade a few degrees to the LEFT . . . now tilt blade back to the RIGHT as far as it will go.
3. Place and ACCURATE square against blade. Make sure square is not touching the TIP of one of the saw TEETH.

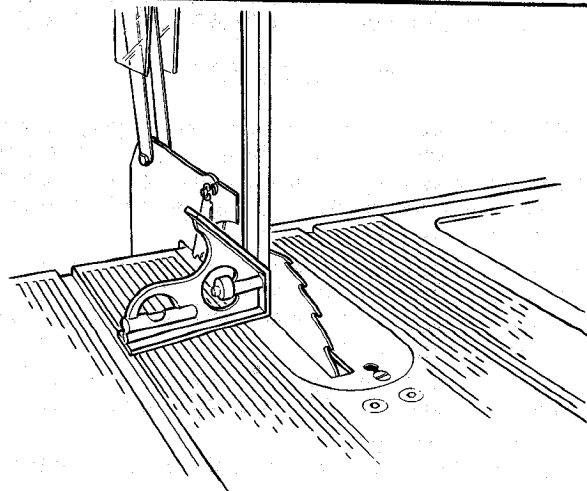

If blade IS SQUARE to table;

A. Check pointer

If POINTER DOES NOT point to the "0" mark on the bevel scale;

B. Loosen screw and adjust pointer . . . using medium screwdriver.

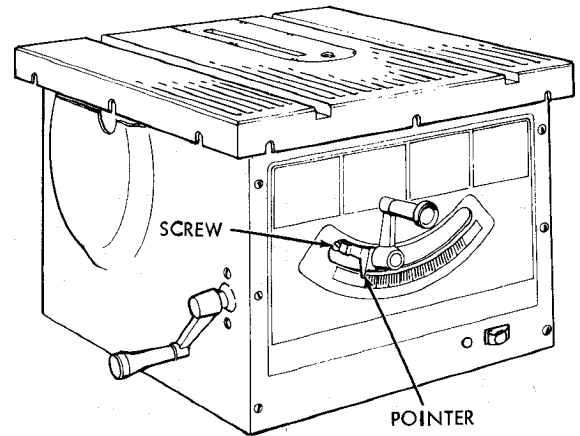

If blade is NOT SQUARE to table . . . the 90° LIMIT STOP must be ADJUSTED.

CAUTION: Cover blade with piece of cardboard to protect your hand.

1. Using a small size screwdriver, reach UNDERNEATH saw and loosen BOTH setscrews in 90° STOP COLLAR.

NOTE: If you can't reach the setscrews, turn the TILT CRANK slightly.

2. ROTATE the STOP COLLAR moving it away from pivot nut.

3. TILT blade RIGHT or LEFT . . . checking with your square until blade is square to table.

4. ROTATE STOP COLLAR moving it toward PIVOT NUT until it TOUCHES the PIVOT NUT . . . TIGHTEN the setscrews.

5. Check POINTER. If it DOES NOT point to the "0" mark on the bevel scale . . . loosen screw and adjust pointer.

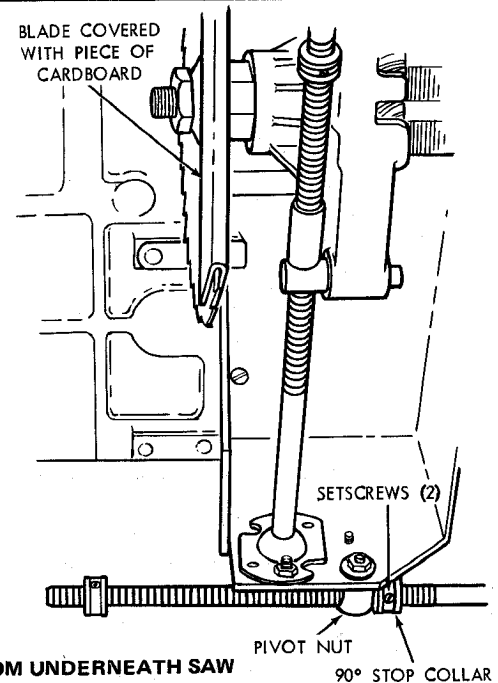

TILT blade to LEFT as far as it will go. It will stop when the PIVOT NUT is against the 45° STOP COLLAR . . . and the pointer SHOULD POINT to the "45" mark on the bevel scale.

If POINTER DOES NOT POINT to the "45" mark . . . the 45° STOP COLLAR must be ADJUSTED.

1. TILT blade all the way to the RIGHT.
2. Remove BLADE GUARD and BLADE.
3. Reach inside of saw from top . . . loosen both setscrews in 45° STOP COLLAR.
4. ROTATE collar moving it toward end of tilt screw.
5. TILT blade until POINTER points to "45" mark.
6. Reach UNDERNEATH saw . . . rotate COLLAR moving it against PIVOT NUT . . . TIGHTEN the setscrews. Pivot nut is visible through curved slot in front of saw.

NOTE: If you can't reach the setscrews, turn TILT CRANK slightly.

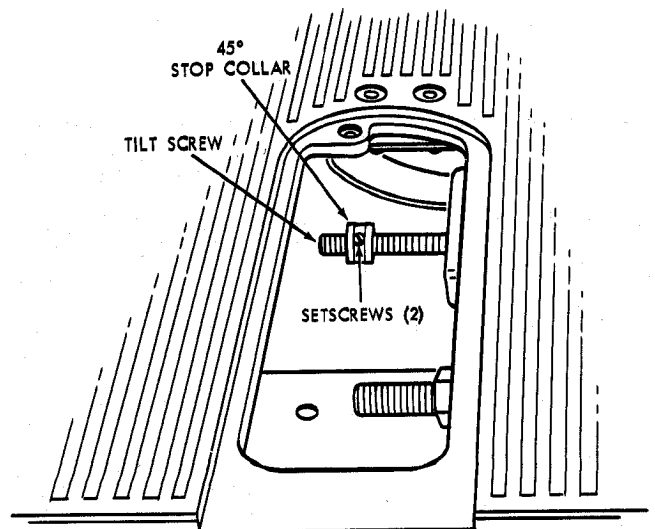

BACK OF SAW

BLADE ELEVATION

When the elevation crank is turned COUNTERCLOCKWISE, until it stops, the blade must not be more than two and one half (2-1/2) inches above the table. If the blade extends more than 2-1/2 inches, the motor could interfere with the underside of the table causing misalignment.

With the blade extending two inches above the table, the STOP COLLAR and SPACER must be against the ELEVATION SCREW PIVOT NUT. If the blade extends more than two and one half inches, loosen two screws in STOP COLLAR, and readjust it.

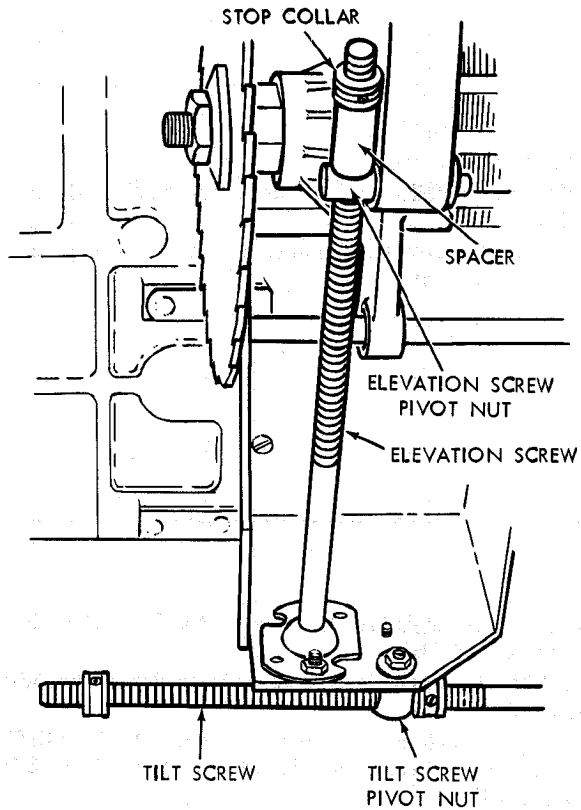

TILT AND ELEVATION MECHANISM

The cranks should turn freely without binding. The turning action can be adjusted by tightening or loosening the screws in the bearing retainer.

NOTE: When adjusting the screws on the tilt crank, hold the nut inside using a 3/8 in. wrench.

The screws for the ELEVATION crank can be reached with a screwdriver through the slot on the front of the saw.

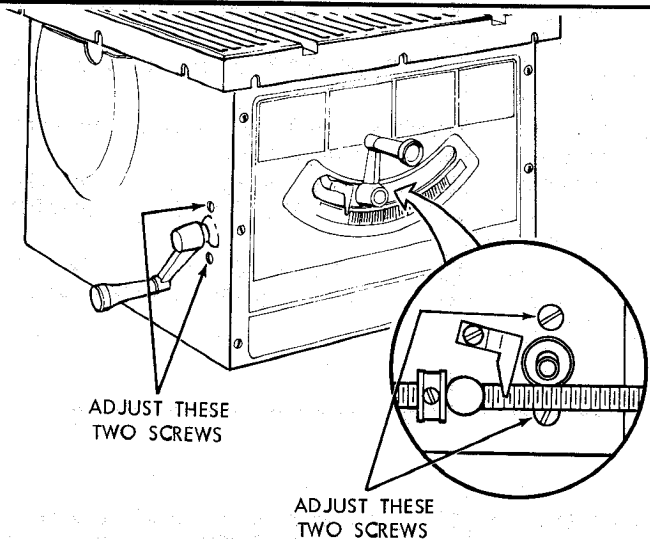

MAINTENANCE

WARNING: FOR YOUR OWN SAFETY, TURN SWITCH "OFF" AND REMOVE PLUG FROM POWER SOURCE OUTLET BEFORE MAINTAINING OR LUBRICATING YOUR SAW.

Do not allow sawdust to accumulate inside the saw. Frequently blow out any dust that may accumulate inside the saw cabinet and the motor.

Frequently clean your cutting tools with Craftsman Gum and Pitch Remover.

A coat of automobile-type wax applied to the table will help to keep the surface clean and allow workpieces to slide more freely. Treat unplated and unpainted steel parts and surfaces with Sears "Stop Rust."

If the power cord is worn or cut, or damaged in any way, have it replaced immediately.

Make sure the teeth of the ANTIKICKBACK pawls are always sharp. To sharpen:

1. Remove blade guard.

2. Rotate pawl toward rear of spreader so that teeth are above top of spreader.
3. Hold spreader with left hand and place pawl over corner of workbench.
4. Using a small round file (Smooth Cut) sharpen the teeth.

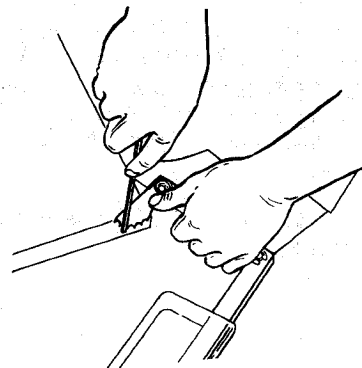

LUBRICATION

The saw motor bearings have been packed at the factory with proper lubricant and require no additional lubrication. The following parts should be oiled occasionally with SAE No. 20 or No. 30 engine oil.

1. Tilt screw threads and pivot nut. (First Clean with Craftsman Gum & Pitch Remover.)
2. Elevation screw threads and pivot nut. (First Clean with Craftsman Gum & Pitch Remover.)
3. Cradle bearing points.
4. Bearing points in guard assembly, miter gauge and rip fence.

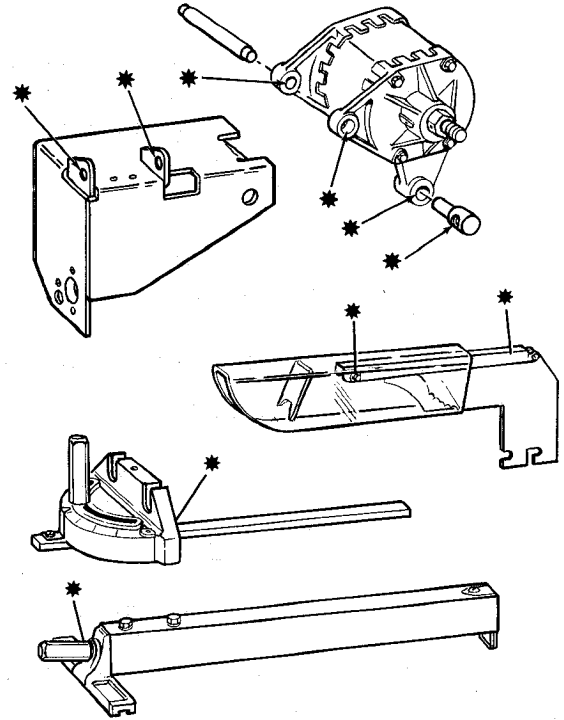
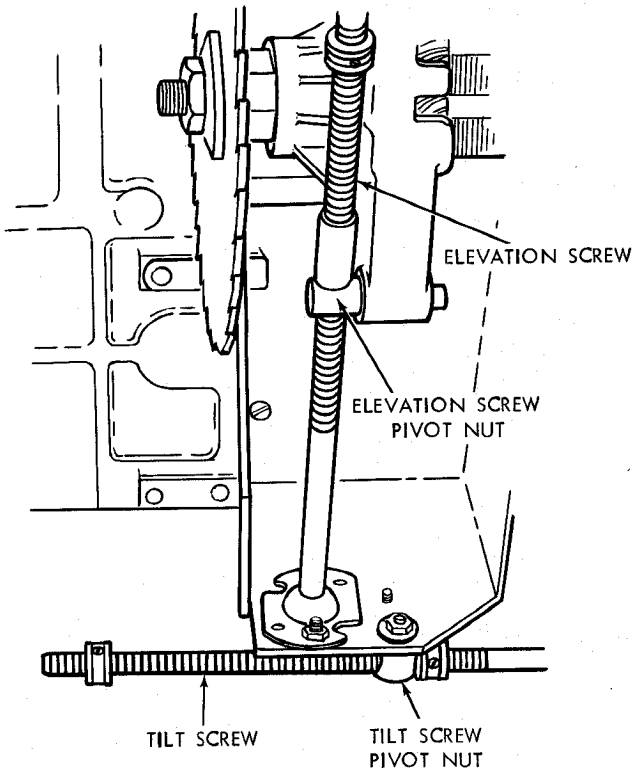

RECOMMENDED ACCESSORIES

IN CANADA, SEE YOUR LOCAL SIMPSONS-SEARS STORE OR CATALOG FOR ACCESSORY SELECTION AND NUMBERS

ITEM	CAT.NO.	ITEM	CAT.NO.
Steel Legs	9-22235	Work Light	9-2481
Steel Stand	9-22214	7 in. Dia. Adjustable Dado Head	9-3263 9-3267
Retractable Caster Set for Steel Legs	9-22209	7 in. Dia. Dado Head	9-3257
Retractable Caster Set for Steel Stand	9-22201	Blade Stabilizers	9-4952
Solid Table Extension	9-29954	Sanding Wheel	9-2274
*7 in. Molding Head Set	9-3217 9-3218	Miter-Gauge Stop Rods	9-29924
*7 in. Molding Head	9-3214	Miter-Gauge Hold-Down Clamp	9-29928
Molding/Dado Insert for 7 in. Dia. Molding or dado Head	9-29933	Hold-Down Set	9-3230
Work Light	9-2480	Taper Jig	9-3233
		Universal Jig	9-3231

"Power Tool Know How Handbook" Table Saw . . 9-2918

The above recommended accessories are current and were available at the time this manual was printed.

*Smaller Dia. Molding Heads cannot be used because they do not provide adequate depth of cut.



TROUBLE SHOOTING

WARNING: FOR YOUR OWN SAFETY, TURN SWITCH "OFF" AND ALWAYS REMOVE PLUG FROM POWER SOURCE OUTLET BEFORE TROUBLESHOOTING.

TROUBLE SHOOTING -- GENERAL

TROUBLE	PROBABLE CAUSE	REMEDY
Excessive vibration.	1. Blade out of balance.	1. Discard Blade and use a different blade.
Cannot make square Cut when crosscutting.	1. Miter gauge not adjusted properly.	1. See "Adjustments" section "Miter Gauge."
Cut binds, burns or stalls motor when ripping.	1. Dull blade with improper tooth set. 2. Blade is Heeling. 3. Warped board. 4. Rip fence not parallel to blade. 5. Spreader out of alignment	1. Sharpen or replace blade. 2. See "Adjustments" section, "Heeling Adjustment . . ." 3. Make sure concave or hollow side is facing "down," feed slowly. 4. See "Assembly" section, "Aligning Rip Fence" 5. See "Assembly" section, "Installing Blade Guard."
Cut not true at 90° or 45° positions.	1. Stop collars not properly adjusted.	1. See "Adjustments" section, "Blade Tilt, or "Squareness of Blade to Table."
Tilt crank and elevating crank turn hard.	1. Sawdust on threads of tilt screw or elevating screw. 2. Bearing retainers to tight.	1. See "Maintenance and Lubrication" section. 2. See "Maintenance" section "Tilt and Elevation Mechanism."

TROUBLE SHOOTING -- MOTOR

NOTE: Motors used on wood-working tools are particularly susceptible to the accumulation of sawdust and wood chips and should be blown out or "vacuumed" frequently to prevent interference with normal motor ventilation.

NOTE: The starting relay is a GRAVITY SENSITIVE TYPE. NEVER TURN THE POWER ON WHILE THE SAW IS UPSIDE DOWN AS THIS WILL DAMAGE THE MOTOR.

TROUBLE	PROBABLE CAUSE	REMEDY
Excessive noise.	1. Motor.	1. Have motor checked by qualified service technician. Repair service is available at your nearest Sears store.
Motor fails to develop full power. (Power output of motor decreases rapidly with decrease in voltage at motor terminals. For example, a reduction of 10% in voltage causes a reduction of 19% in maximum power output of which the motor is capable, while a reduction of 20% in voltage causes a reduction of 36% in maximum power output.)	1. Circuit overloaded with lights, appliances and other motors. 2. Undersize wires or circuit too long. 3. General overloading of power company facilities. (In some sections of the country, demand for electrical power may exceed the capacity of existing generating and distribution systems.) 4. Incorrect fuses or circuit breakers in power line.	1. Do not use other appliances or motors on same circuit when using the saw. 2. Increase wire sizes, or reduce length of wiring. See "Motor Specification and Electrical Requirements" section. 3. Request a voltage check from the power company. 4. Install correct fuses or circuit breakers.

TROUBLE SHOOTING -- MOTOR (Continued)

TROUBLE	PROBABLE CAUSE	REMEDY
Motor starts slowly or fails to come up to full speed.	<ol style="list-style-type: none"> 1. Low voltage will not trip relay. 2. Windings burned out or open. 3. Starting relay not operating. 	<ol style="list-style-type: none"> 1. Request voltage check from the power company. 2. Have motor repaired or replaced. 3. Have relay replaced.
Motor overheats.	<ol style="list-style-type: none"> 1. Motor overloaded. 2. Improper cooling. (Air circulation restricted through motor due to sawdust, accumulating inside of saw). 	<ol style="list-style-type: none"> 1. Feed work slower into blade. 2. Clean out sawdust to provide normal air circulation through motor. See "Maintenance and Lubrication" section.
Starting relay in motor will not operate.	<ol style="list-style-type: none"> 1. Burned relay contacts (due to extended hold-in periods caused by low line voltage, etc.) 2. Saw not in upright position. 3. Loose or broken connections. 	<ol style="list-style-type: none"> 1. Have relay replaced and request a voltage check from the power company. 2. Place saw in upright position. 3. Have wiring checked and repaired.
Motor stalls (resulting in blown fuses or tripped circuit breakers).	<ol style="list-style-type: none"> 1. Starting relay not operating. 2. Voltage too low to permit motor to reach operating speed. 3. Fuses or circuit breakers do not have sufficient capacity. 	<ol style="list-style-type: none"> 1. Have relay replaced. 2. Request voltage check from the power company. 3. Install proper size fuses or circuit breakers.
Frequent opening of fuses or circuit breakers.	<ol style="list-style-type: none"> 1. Motor overloaded. 2. Fuses or circuit breakers do not have sufficient capacity. 3. Starting relay not operating (motor does not reach normal speed). 	<ol style="list-style-type: none"> 1. Feed work slower into blade. 2. Install proper size fuses or circuit breakers. 3. Have relay replaced.

PARTS LIST FOR CRAFTSMAN 10 INCH MOTORIZED SAW
 MODEL NO. 113.29580 & 113.295820

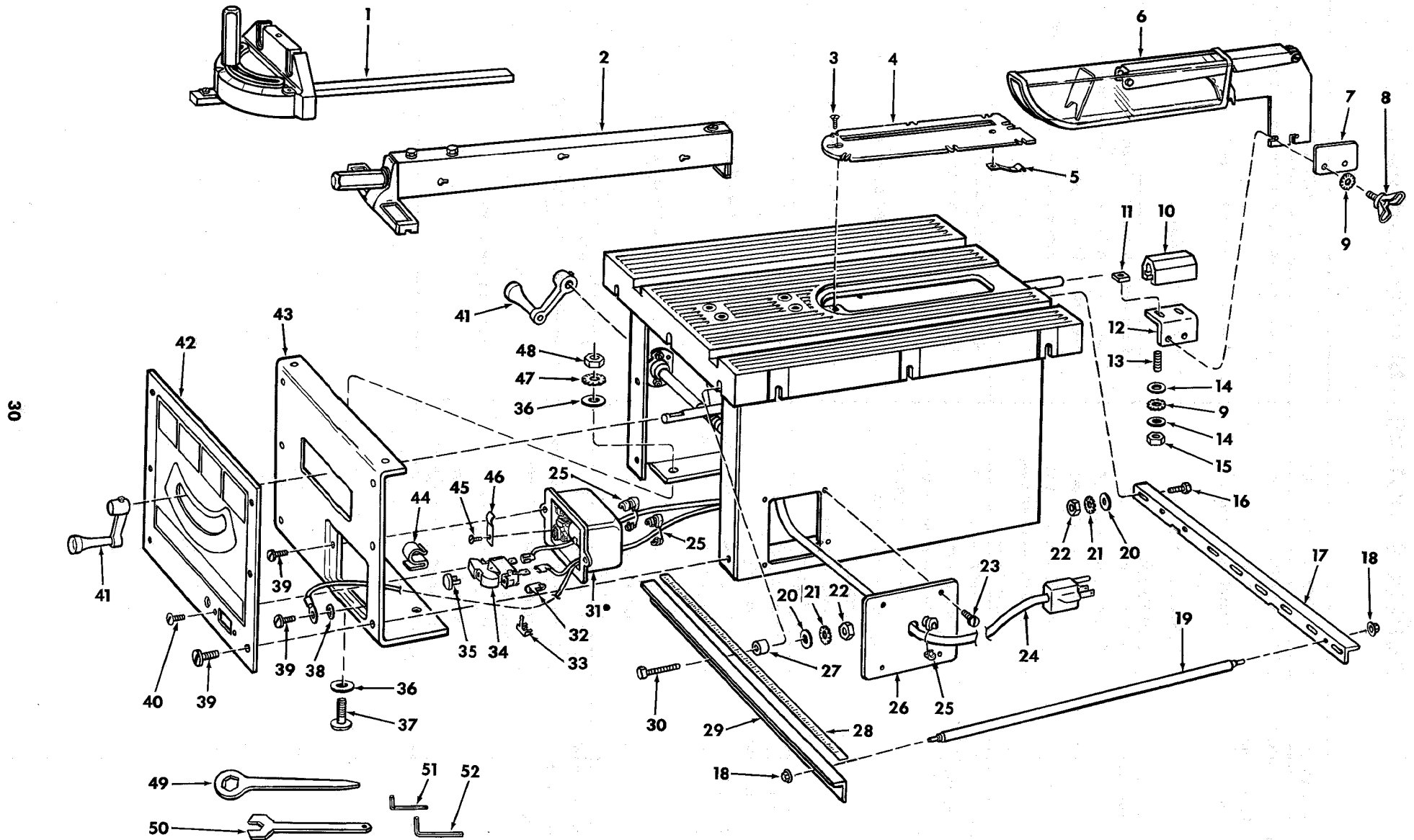

Figure 1

**PARTS LIST FOR CRAFTSMAN 10 INCH MOTORIZED SAW
MODEL NO. 113.29580 & 113.295820**

Always order by Part Number — not by Key Number

FIGURE 1 PARTS LIST

Key No.	Part No.	Description
1	62523	Gauge Assembly, Miter (See Figure 4)
2	62525	Fence Assembly, Rip (See Figure 3)
3	447441	Screw, Flat Hd. Type "T" 10-32 x 7/8
4	62514	Insert Assembly (Includes Key No. 5)
5	62545	Clip, Retaining
6	62655	Guard Assembly (See Figure 5)
7	62643	Clamp, Spreader
8	30540	Screw, Wing 1/4-20 x 1/2
9	STD 551225	*Lockwasher, External Tooth 1/4
10	62642	Support, Spreader
11	62636	*Nut, Square 1/4-20
12	62644	Bracket
13	139331	Screw, Set Hex Cup 1/4-20 x 7/8
14	STD 551012	*Washer, 17/64 x 9/16 x 1/16
15	STD 541025	*Nut, Hex 1/4-20
16	STD 523110	Screw, Hex Hd. 5/16-18 x 1
17	62541	Bar, Fence Rear
18	60313	Nut, Self Threading
19	62542	Rod, Separation
20	STD 551031	Washer, 21/64 x 5/8 x 1/16
21	STD 551131	*Lockwasher, External Tooth 5/16
22	STD 541031	*Nut, Hex, 5/16-18
23	STD 600603	Screw, Ty "T" Pan Hd. 6-32 x 3/8
24	62441	Cord with Plug
25	37818	Relief, Strain
26	62652	Plate, Cover
27	62539	Spacer, Fence Guide Bar
28	62544	Tape, Fence

Key No.	Part No.	Description
29	62540	Bar Assembly, Fence Guide (Includes Key No. 28)
30	STD 523115	*Screw, Hex, 5/16-18 x 1-1/2
31	62505	•Motor and Control Box
32	63467	Cap — Flag Term
33	62267	Clip, Capacitor
34	62442	Switch, Locking
35	60256	Key, Switch
36	STD 551025	*Washer, 17/64 x .734 x .062
37	60314	Screw, Truss 1/4-20 x 5/8
38	STD 551208	*Lockwasher, External Tooth No. 8
39	STD 610805	Screw, Pan Hd., Ty "AB" No. 8 x 1/2
40	STD 600602	*Screw, Type 23, Pan Hd., 6-32 x 1/4
41	62333	Crank Assembly, w/Set Screw
42	62654	Panel, Trim
43	62653	Panel, Front
44	62204	Clip, Cord
45	STD 610802	*Screw, Pan Hd., Type B, No. 8 x 5/16
46	62452	Clamp, Relay
47	STD 551225	*Lockwasher, External Tooth 1/4
48	STD 541025	Nut, Hex 1/4-20
49	3540	Wrench, Arbor
50	63062	Wrench, Shaft
51	30505	Wrench, Hex "L" 1/8
52	37911	Wrench, Hex "L" 3/16
—	62658	Bag of Loose Parts (Not Illustrated)
—	62657	Owners Manual (Not Illustrated)

* Standard Hardware Item — May be Purchased Locally.

• Any attempt to repair this motor may create a HAZARD unless repair is done by a qualified service technician. Repair service is available at your nearest Sears Store.

**PARTS LIST FOR CRAFTSMAN 10 INCH MOTORIZED SAW
MODEL NO. 113.29580 & 113.295820**

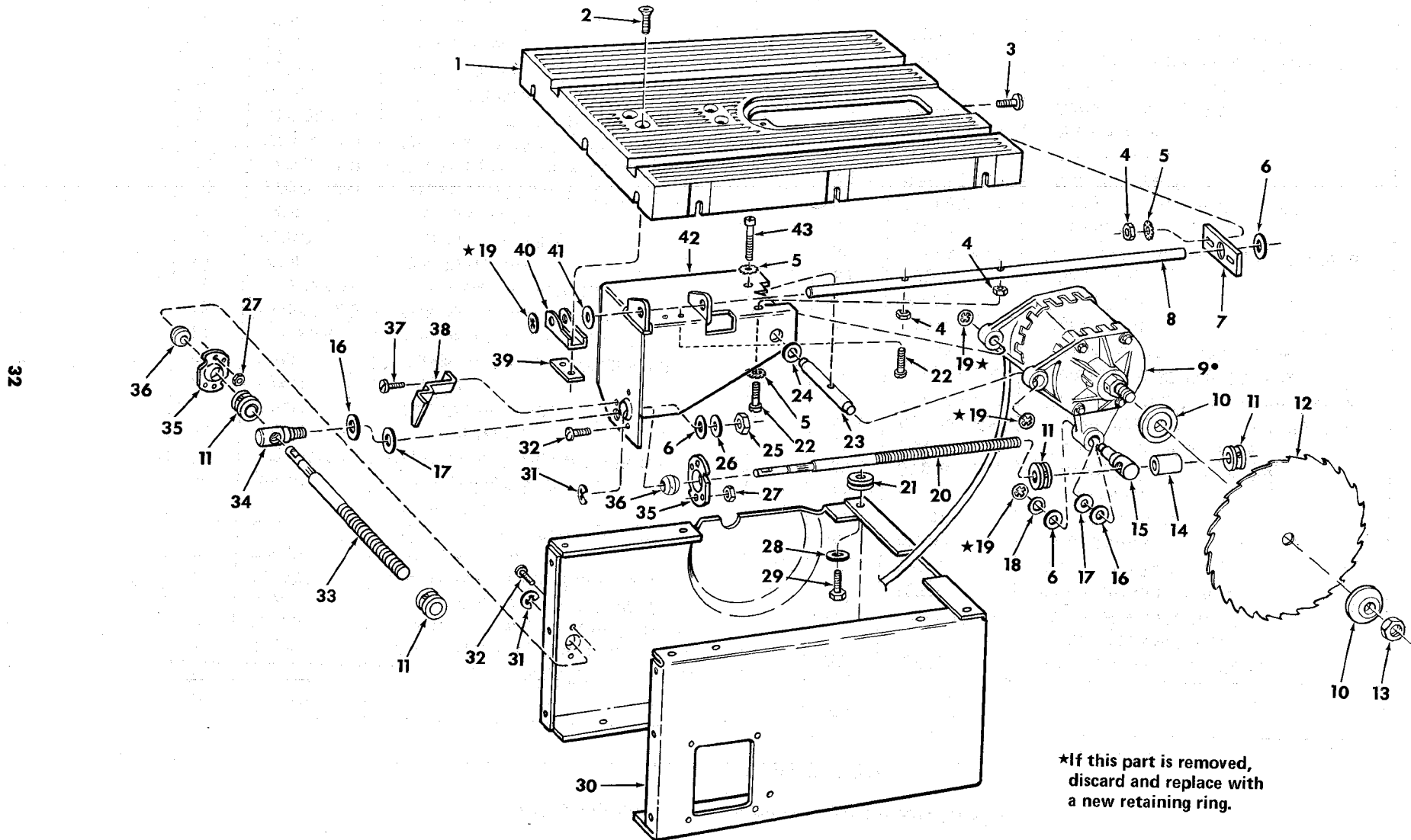

Figure 2

**PARTS LIST FOR CRAFTSMAN 10 INCH MOTORIZED SAW
MODEL NO. 113.29580 & 113.295820**

FIGURE 2 PARTS LIST

Key No.	Part No.	Description
1	62628	Table, Saw
2	805297-1	Screw, Flat Hd. 5/16-18 x 1-1/4
3	STD 511107	*Screw, Pan Hd. 10-32 x 3/4
4	STD 541110	*Nut, Hex No. 10-32
5	STD 551210	*Lockwasher, External Tooth No. 10
6	62648	Washer, Rubber
7	62629	Support, Rod
8	62624	Rod, Cradle
9	62505	• Motor and Control Box
10	62445	Collar, Blade
11	37900	Collar, Stop
12	60175	+Blade, Saw 10 inch
13	6362	Nut, Arbor
14	60303	Spacer
15	62646	Nut, Pivot
16	60328	Washer, Nylon
17	62647	Washer, Rubber
18	STD 551037	*Washer, 13/32 x .625 x .062
19	60301	*Ring, Retaining
20	62630	Screw, Elevation
21	62649	Grommet, Rubber
22	STD 511110	*Screw, Pan No. 10-32 x 1

Key No.	Part No.	Description
23	62651	Rod, Motor
24	60076	Washer, .505 x 1-1/8 x 1/16
25	STD 541425	*Nut, Lock 1/4-20
26	STD 551025	*Washer, 17/64 x .734 x .062
27	STD 541411	*Nut, Lock 10-32
28	STD 551031	*Washer 21/64 x 3/4 x 1/16
29	STD 523110	*Screw, Hex Washer 5/16-18 x 1
30	62633	Base, Saw
31	60045	Ring, Retaining
32	STD 511105	Screw, Pan Hd. 10-32 x 1/2
33	62438	Screw, Tilt
34	62645	Nut, Pivot
35	62437	Retainer, Bearing
36	62306	Bearing
37	STD 600803	*Screw, Type "T" Pan 8-32 x 3/8
38	62632	Indicator, Bevel
39	62436	Nut
40	62625	Hanger
41	62435	Washer, Thrust
42	62623	Cradle Assembly
43	60052	*Screw, Fillister Hd. 10-32 x 1-1/2

* Standard Hardware Item – May be Purchased Locally.

- Any attempt to repair this motor may create a HAZARD unless repair is done by a qualified service technician. Repair service is available at your nearest Sears Store.

+ Stock Item – May be secured through the hardware departments of most Sears or Simpson-Sears Retail Stores or Catalog Order Houses.

- ★ If this part is removed, discard and replace with a new retaining ring.

**PARTS LIST FOR CRAFTSMAN 10 INCH MOTORIZED SAW
MODEL NO. 113.29580 & 113.295820**

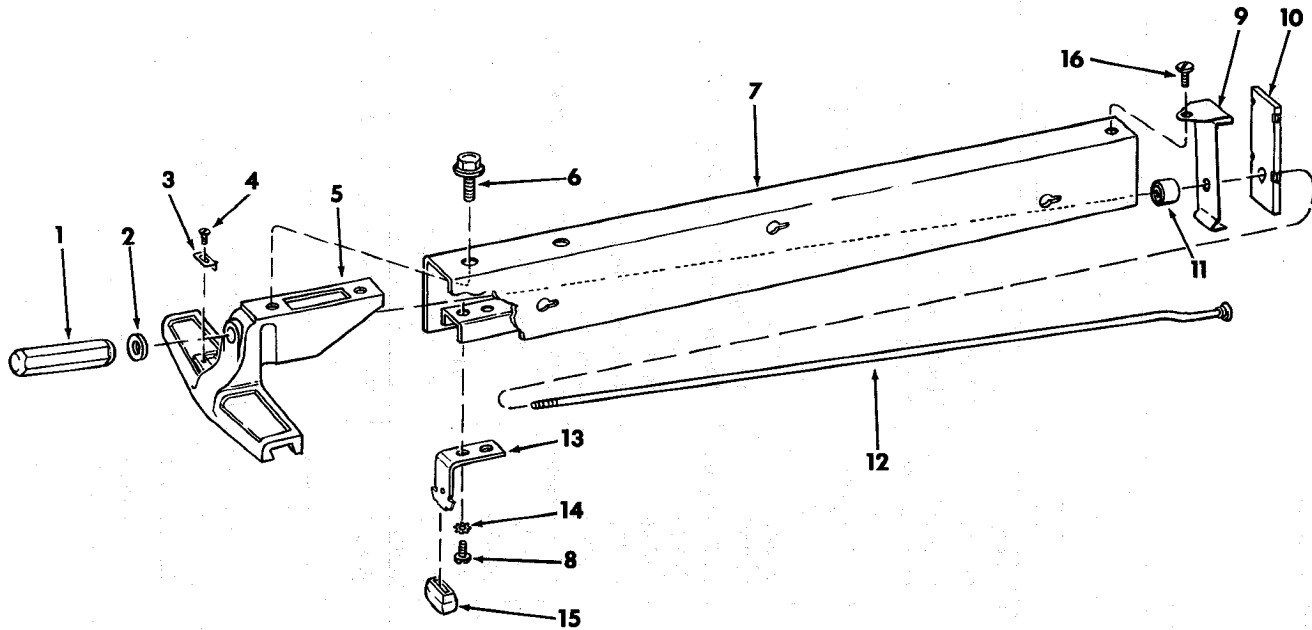

FIGURE 3 – 62525 FENCE ASSEMBLY

Key No.	Part No.	Description
—	62525	Fence Assembly, Rip
1	62524	Handle
2	STD 551031	*Washer, 21/64 x 1/2 x 1/32
3	62534	Indicator, Fence
4	60049	*Screw, Pan Hd. Type "T" 4-40 x 3/16
5	62527	Head, Fence
6	423350	Screw, Sems 3/8-16 x 1/2
7	62526	Channel, Fence
8	STD 611005	*Screw, Pan Hd. Type "A" 10-32 x 5/8
9	62528	Spring, Fence Lock
10	62529	Lock, Rear Fence
11	62531	Roller, Rear Fence
12	62530	Rod, Fence Lock
13	62533	Spring, Head Alignment
14	STD 551210	*Lockwasher, External Tooth No. 10
15	62532	Pad, Alignment
16	STD 600805	Screw, Pan Hd. Type "T" 8-32 x 1/2

* Standard Hardware Item – May be Purchased Locally.



**PARTS LIST FOR CRAFTSMAN 10 INCH MOTORIZED SAW
MODEL NO. 113.29580 & 113.295820**

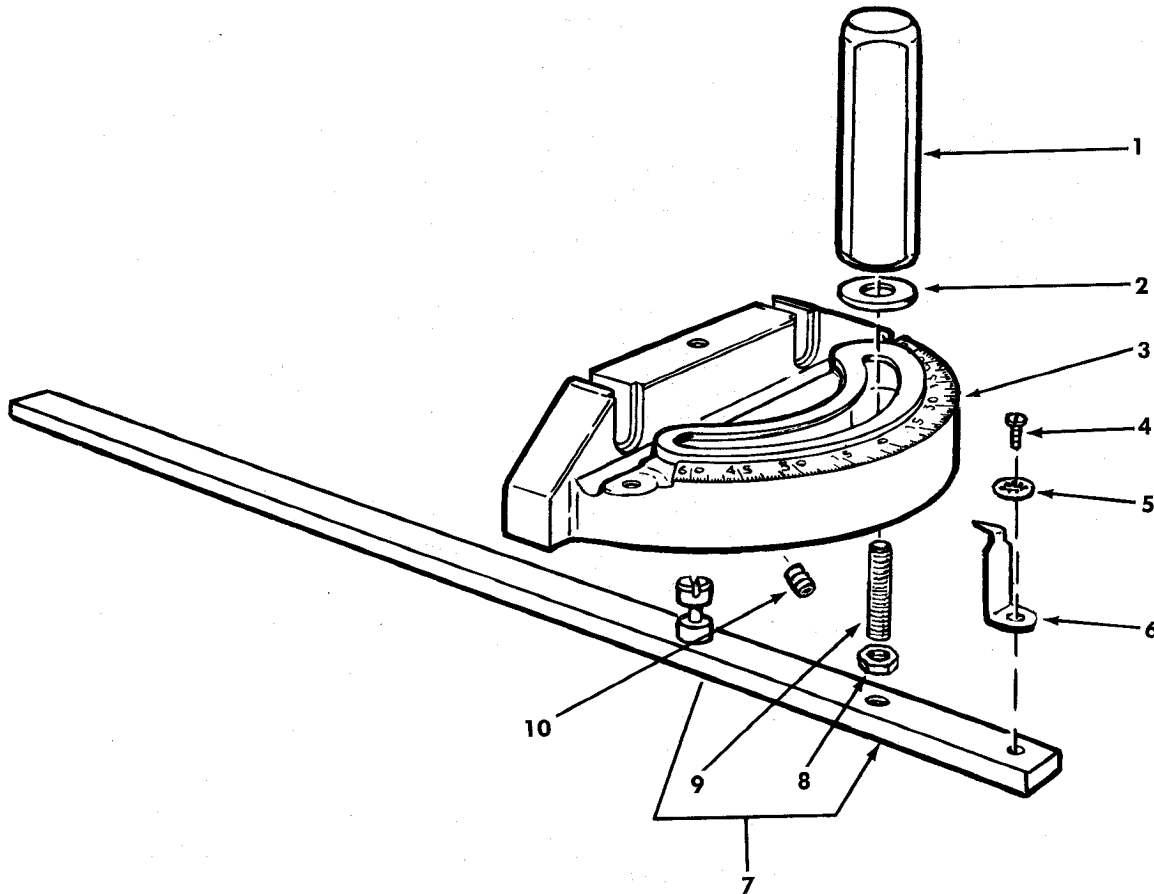

FIGURE 4 – 62523 MITER GAUGE ASSEMBLY

Key No.	Part No.	Description
—	62523	†Gauge Assembly, Miter
1	62524	Handle, Miter Gauge
2	STD 551031	*Washer, Plain, .320 x 1 x 1/16"
3	62014	Gauge, Miter
4	STD 600803	*Screw, Mach., No. 8-32 x 5/16" Pan Hd. Slotted
5	STD 551208	*Lockwasher, External Tooth No. 8
6	62042	Indicator
7	62252	Rod Assembly, Miter Gauge Includes Key Nos. 8 & 9
8	STD 541231	*Nut, Hex—5/16-18
9	62225	Stud, Clamp
10	STD 60288	*Screw, Set, Locking 1/4-20 x 3/8", Hex Socket Hd., Cone Pt.

* Standard Hardware Item — May be Purchased Locally.

† Stock Item — May be secured through the hardware departments of most Sears or Simpson-Sears Retail Stores or Catalog Order Houses.

**PARTS LIST FOR CRAFTSMAN 10 INCH MOTORIZED SAW
MODEL NO. 113.29580 & 113.295820**

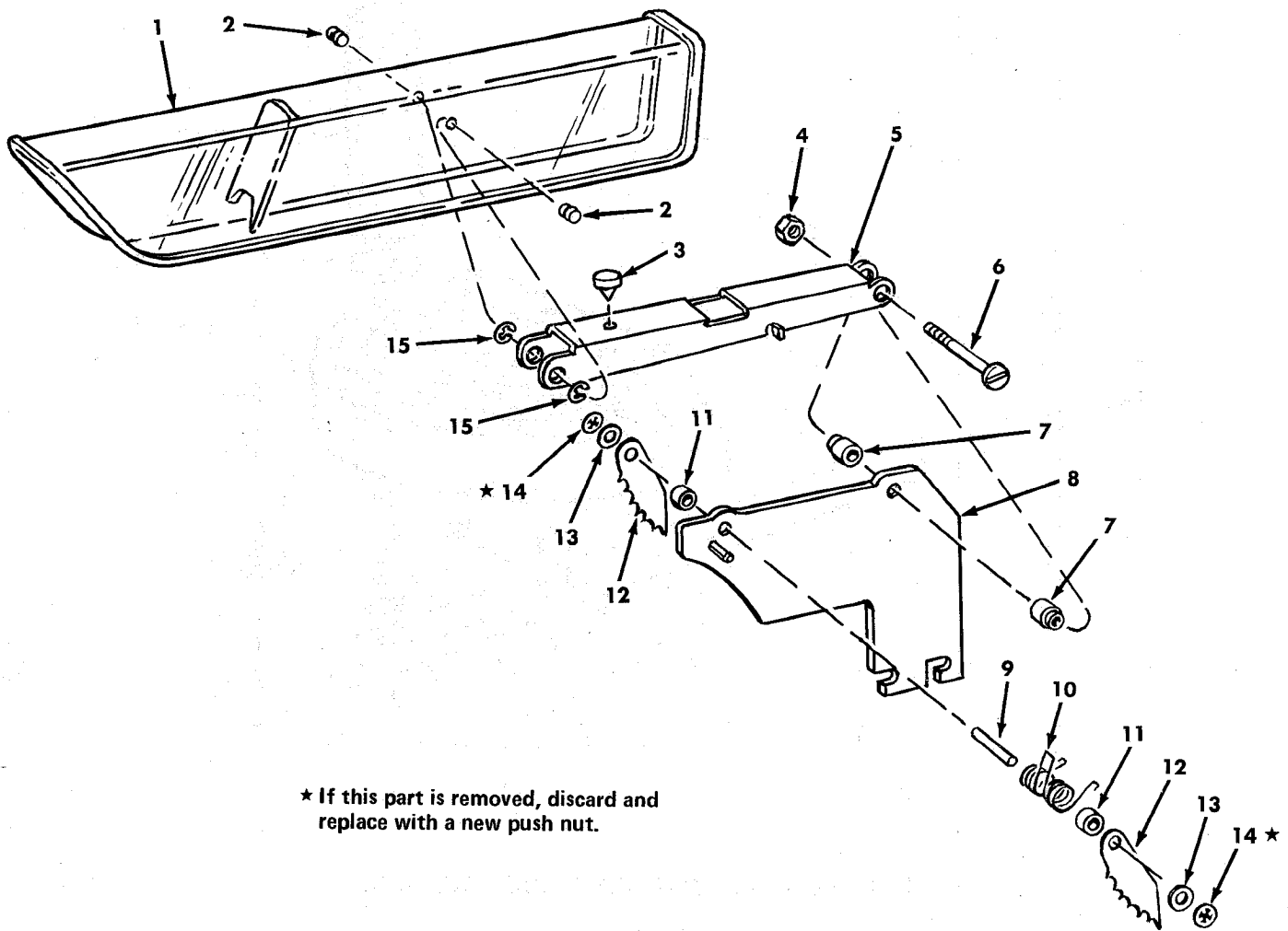

* If this part is removed, discard and replace with a new push nut.

FIGURE 5 – 62655 GUARD ASSEMBLY

Key No.	Part No.	Description
—	62655	Guard Assembly
1	62415	Guard
2	62516	Pin
3	62650	Bumper, Snap In
4	STD 541425	*Nut, Lock 1/4-20
5	62517	Link, Guard
6	STD 512515	*Screw, Pan Hd., 1/4-20 x 1-1/2
7	62522	Spacer, Link
8	62656	Blade, Spreader
9	62410	Pin, 1/4 x 1-3/64
10	62519	Spring, Pawl
11	62520	Spacer, Pawl
12	62521	Pawl
13	STD 551012	*Washer, 17/64 x 1/2 x 1/32
14	60297	*Nut, Push
15	STD 581025	*Ring, Retaining 1/4

* Standard Hardware Item – May be Purchased Locally.

**PARTS LIST FOR CRAFTSMAN 10 INCH MOTORIZED SAW
MODEL NO. 113.29580 & 113.295820**

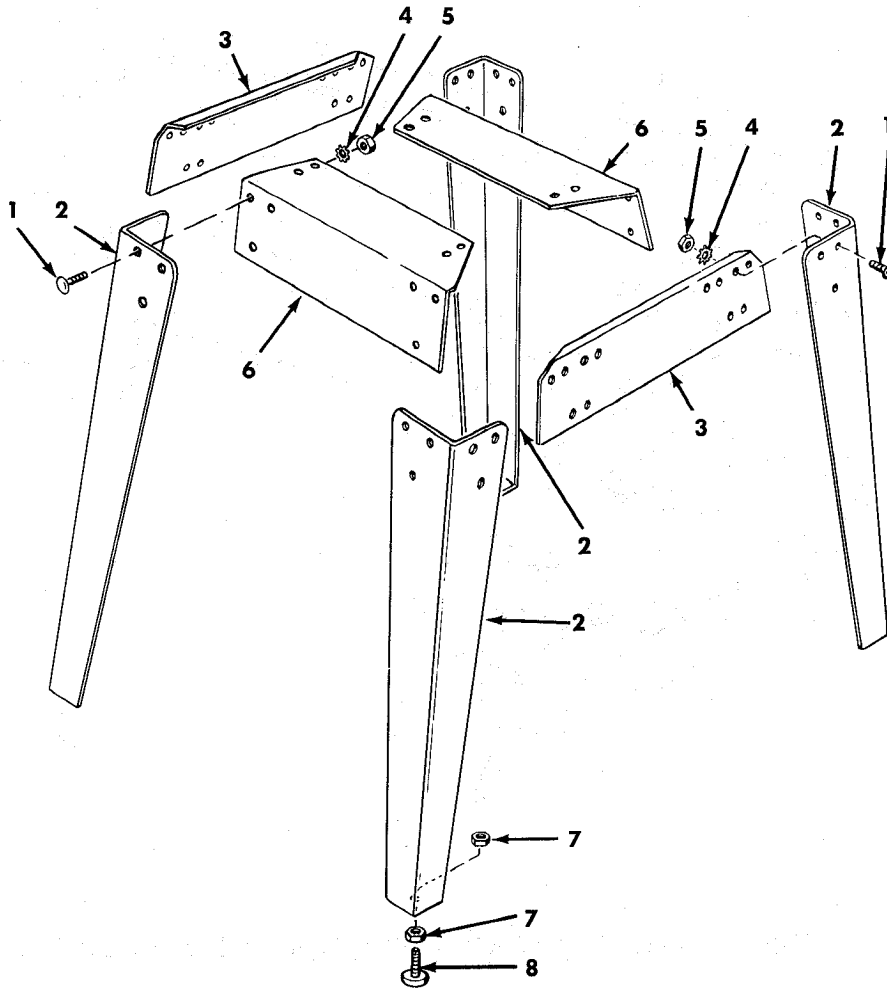

**FIGURE 6 – MODEL 113.295820 ONLY
(NOT SUPPLIED IN CANADA)**

Key No.	Part No.	Description
1	60314	Screw, Serrated Truss Hd. 1/4-20 x 5/8
2	62552	Leg
3	62554	Stiffener, Side
4	STD 551225	*Lockwasher, Ext. 1/4
5	STD 541025	*Nut, Hex 1/4-20
6	62553	Stiffener, End
7	STD 541250	*Nut, Hex 1/2-13
8	803835	Foot, Leveling
	62659	†Bag of Loose Parts (not illustrated)

* Standard Hardware Items – May be Purchased Locally.

† Bag contains all Loose Parts for both Legs and Extensions

**PARTS LIST FOR CRAFTSMAN 10 INCH MOTORIZED SAW
MODEL NO. 113.29580 & 113.295820**

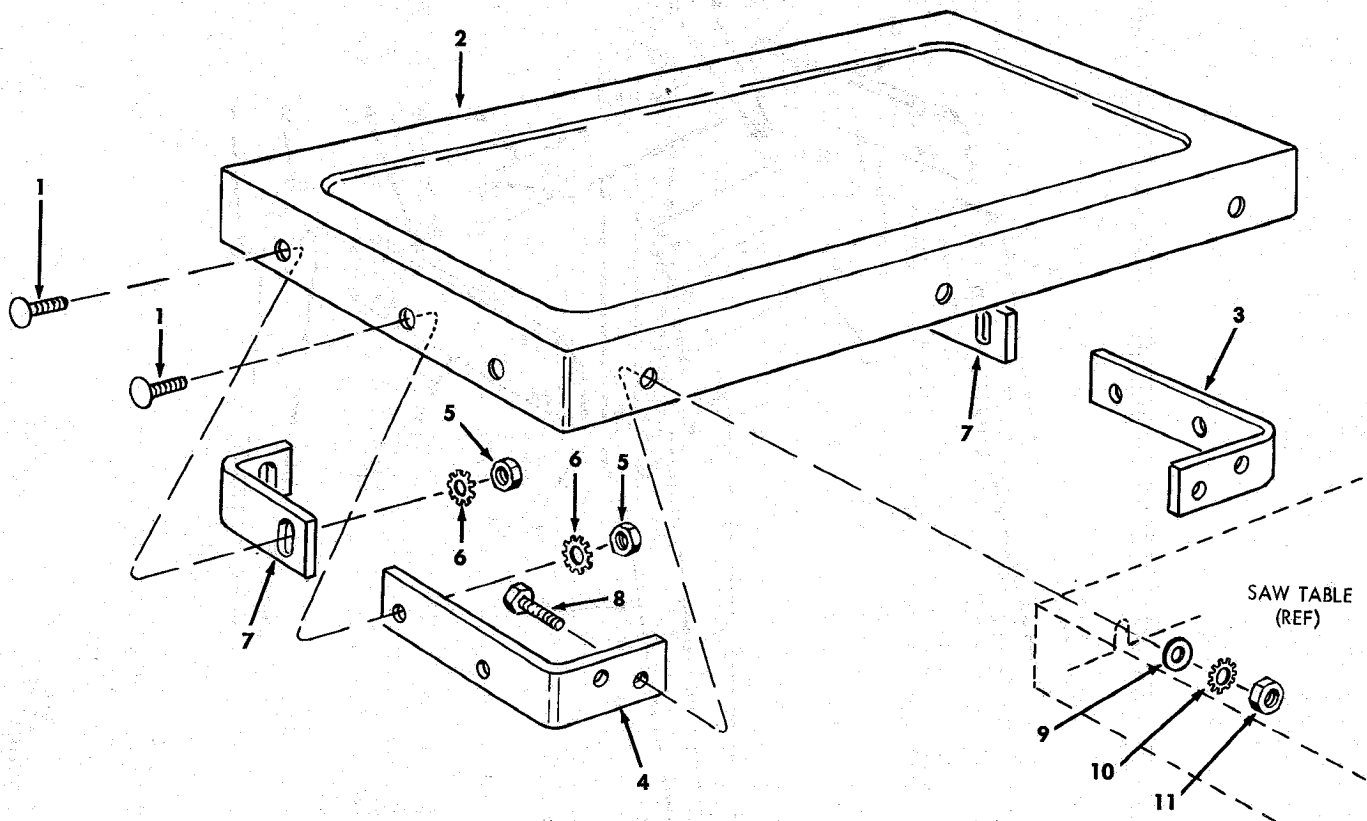

FIGURE 7 – TABLE EXTENSION FOR MODEL 113.295820 ONLY

Key No.	Part No.	Description
—	62546	Extension Assembly, Complete
1	60323	Screw, Serrated Truss Hd. 1/4-20 x 1"
2	62547	Extension
3	62549	Bracket, Corner Support No. 2
4	62548	Bracket, Corner Support No. 1
5	STD 541025	*Nut, Hex 1/4-20
6	STD 551225	*Lockwasher, Ext. 1/4
7	62550	Bracket, Corner Stiffener
HARDWARE FOR ATTACHING EXTENSION TO TABLE		
8	STD 523112	*Screw, Hex Hd. 5/16-18 x 1-1/4
9	STD 551031	*Washer, 11/32 x 11/16 x 1/16
10	STD 551131	*Lockwasher, Ext. 5/16
11	STD 541031	*Nut, Hex 5/16-18
	62659	†Bag of Loose Parts (not illustrated)

* Standard Hardware Item – May be Purchased Locally.

† Bag contains all Loose Parts for both Legs and Extension.

Sears

*owners
manual*

SERVICE

MODEL NO.

113.29580

SAW ONLY

113.295820

SAW WITH LEGS AND
TWO TABLE EXTENSIONS

HOW TO ORDER REPAIR PARTS

10 INCH MOTORIZED TABLE SAW

Now that you have purchased your 10 inch motorized table saw should a need ever exist for repair parts or service, simply contact any Sears Service Center and most Sears, Roebuck and Co. stores. Be sure to provide all pertinent facts when you call or visit.

The model number of your 10 inch motorized table saw will be found on a plate attached to your saw, at the right-hand side of the base.

WHEN ORDERING REPAIR PARTS, ALWAYS GIVE THE FOLLOWING INFORMATION:

PART NUMBER	PART DESCRIPTION
MODEL NUMBER	NAME OF ITEM
113.29580 or	10-INCH MOTORIZED TABLE SAW
113.295820	

All parts listed may be ordered from any Sears Service Center and most Sears stores. If the parts you need are not stocked locally, your order will be electronically transmitted to a Sears Repair Parts Distribution Center for handling.

Sold by SEARS, ROEBUCK AND CO., Chicago, IL. 60684 U.S.A.