

Owner's Manual

CRAFTSMAN®

10 in. COMPOUND MITER SAW Double Insulated

Model No.
315.243000

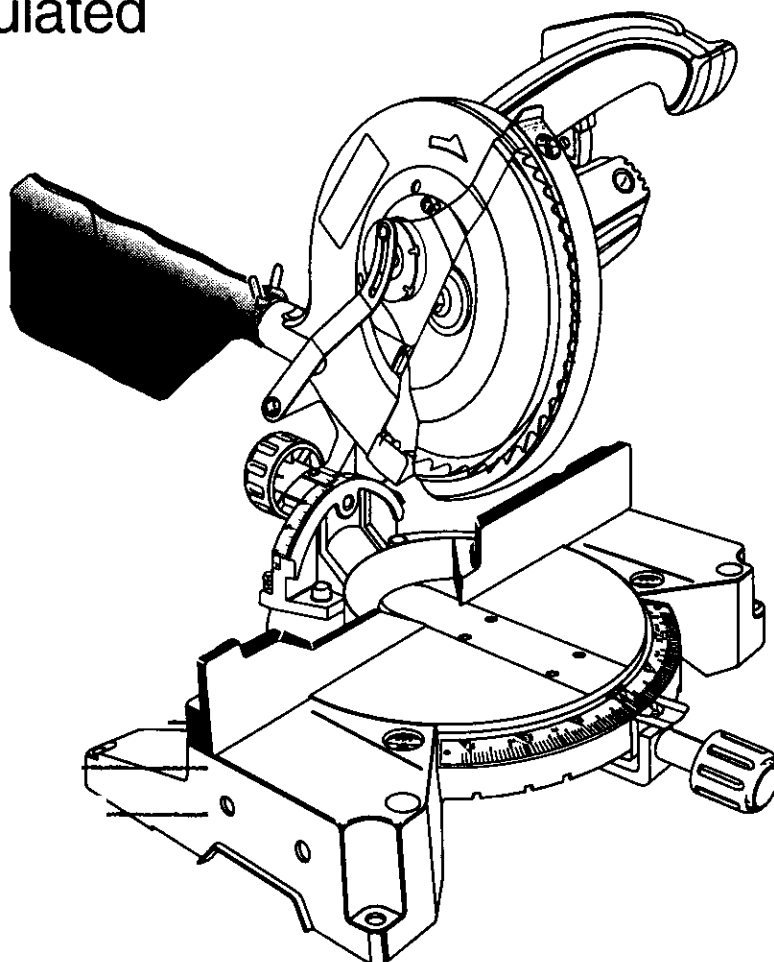

Save this manual for
future reference

⚠ CAUTION: Read and follow
all Safety Rules and Operating
Instructions before first use of
this product.

Customer Help Line: 1-800-932-3188

Sears, Roebuck and Co., Hoffman Estates, IL 60179 USA
Visit the Craftsman web page: www.sears.com/craftsman

972000-710
1-00

- Safety
- Features
- Adjustments
- Operation
- Maintenance
- Parts List



TABLE OF CONTENTS

| | |
|--|-------|
| ■ Table of Contents | 2 |
| ■ Warranty and Introduction | 2 |
| ■ Rules For Safe Operation | 3-6 |
| ■ Glossary | 6 |
| ■ Product Specifications and Unpacking | 7 |
| ■ Labels | 8 |
| ■ Loose Parts and Tools Needed | 9 |
| ■ Features | 10-12 |
| ■ Adjustments | 12-19 |
| ■ Operation | 20-26 |
| ■ Maintenance | 27-28 |
| ■ Exploded View and Repair Parts List | 30-37 |
| ■ Parts Ordering / Service | 38 |

WARRANTY

FULL ONE YEAR WARRANTY

If this product fails due to a defect in material or workmanship within one year from the date of purchase, Sears will repair it free of charge.

Contact a Sears Service Center for repair.

If this product is used for commercial or rental purposes, this warranty applies only for 90 days from the date of purchase.

This warranty gives you specific legal rights, and you may also have other rights which vary from state to state.

Sears, Roebuck and Co., Dept. 817WA, Hoffman Estates, IL 60179

INTRODUCTION

Your saw has many features for making cutting operations more pleasant and enjoyable. Safety, performance and dependability have been given top priority in the design of this saw making it easy to maintain and operate.

⚠ CAUTION: Carefully read through this entire owner's manual before using your new saw. Pay close attention to the Rules For Safe Operation, and all Safety Alert Symbols including Danger, Warning and Caution. If you use your saw properly and only for what it is intended, you will enjoy years of safe, reliable service.

⚠ Look for this symbol to point out important safety precautions. It means 'attention!!! Your safety is involved.

⚠ WARNING:



The operation of any power tool can result in foreign objects being thrown into your eyes, which can result in severe eye damage. Before beginning power tool operation, always wear safety goggles or safety glasses with side shields and a full face shield when needed. We recommend Wide Vision Safety Mask for use over eyeglasses or standard safety glasses with side shields, available at Sears Retail Stores.

RULES FOR SAFE OPERATION

The purpose of safety symbols is to attract your attention to possible dangers. The safety symbols, and the explanations with them, deserve your careful attention and understanding. The safety warnings do not by themselves eliminate any danger. The instructions or warnings they give are not substitutes for proper accident prevention measures.

SYMBOL MEANING



SAFETY ALERT SYMBOL:

Indicates danger, warning or caution. May be used in conjunction with other symbols or pictographs.



DANGER: Failure to obey a safety warning will result in serious injury to yourself or to others. Always follow the safety precautions to reduce the risk of fire, electric shock and personal injury.



WARNING: Failure to obey a safety warning can result in serious injury to yourself or to others. Always follow the safety precautions to reduce the risk of fire, electric shock and personal injury.



CAUTION: Failure to obey a safety warning may result in property damage or personal injury to yourself or to others. Always follow the safety precautions to reduce the risk of fire, electric shock and personal injury.

NOTE: Advises you of information or instructions vital to the operation or maintenance of the equipment.

DOUBLE INSULATION

Double insulation is a concept in safety, in electric power tools, which eliminates the need for the usual three-wire grounded power cord. All exposed metal parts are isolated from internal metal motor components with protecting insulation. Double insulated tools do not need to be grounded.

 **WARNING:** Do not attempt to operate this tool until you have read thoroughly and understand completely all instructions, safety rules, etc. contained in this manual. Failure to comply can result in accidents involving fire, electric shock, or serious personal injury. Save owner's manual and review frequently for continuing safe operation, and instructing others who may use this tool.

READ ALL INSTRUCTIONS

- **KNOW YOUR POWER TOOL.** Read the owner's manual carefully. Learn the saw's applications and limitations as well as the specific potential hazards related to this tool.
- **GUARD AGAINST ELECTRICAL SHOCK BY PREVENTING BODY CONTACT WITH GROUNDED SURFACES.** For example, pipes, radiators, ranges, refrigerator enclosures.
- **KEEP GUARDS IN PLACE** and in good working order.
- **REMOVE ADJUSTING KEYS AND WRENCHES.** Get in the habit of checking to see that hex keys and adjusting wrenches are removed from tool before turning on saw.

IMPORTANT

Servicing requires extreme care and knowledge of the system and should be performed only by a qualified service technician. For service we suggest you return the tool to your nearest Sears store for repair. Always use original factory replacement parts when servicing.

- **KEEP THE WORK AREA CLEAN.** Cluttered work areas and work benches invite accidents. **DO NOT** leave tools or pieces of wood on the saw while it is in operation.
- **DO NOT USE IN DANGEROUS ENVIRONMENTS.** Do not use power tools near gasoline or other flammable liquids, in damp or wet locations, or expose them to rain. Keep the work area well lit.
- **KEEP CHILDREN AND VISITORS AWAY.** All visitors should wear safety glasses and be kept a safe distance from work area. Do not let visitors contact tool or extension cord while operating.
- **MAKE WORKSHOP CHILD-PROOF** with padlocks and master switches, or by removing starter keys.
- **DO NOT FORCE THE TOOL.** It will do the job better and safer at the rate for which it was designed.
- **USE THE RIGHT TOOL.** Do not force the tool or attachment to do a job it was not designed for. Don't use it for a purpose not intended.

RULES FOR SAFE OPERATION (Continued)

- **USE THE PROPER EXTENSION CORD.** Make sure your extension cord is in good condition. When using an extension cord, be sure to use one heavy enough to carry the current your product will draw. An undersized cord will cause a drop in line voltage resulting in loss of power and overheating. A wire gage size (A.W.G.) of at least **14** is recommended for an extension cord 25 feet or less in length. If in doubt, use the next heavier gage. The smaller the gage number, the heavier the cord.
 - **INSPECT EXTENSION CORDS PERIODICALLY** and replace if damaged.
 - **DRESS PROPERLY.** Do not wear loose clothing, gloves, neckties, rings, bracelets, or other jewelry. They can get caught and draw you into moving parts. Rubber gloves and nonslip footwear are recommended when working outdoors. Also wear protective hair covering to contain long hair.
 - **ALWAYS WEAR SAFETY GLASSES WITH SIDE SHIELDS.** Everyday eyeglasses have only impact-resistant lenses; they are **NOT** safety glasses.
 - **PROTECT YOUR LUNGS.** Wear a face or dust mask if the cutting operation is dusty.
 - **PROTECT YOUR HEARING.** Wear hearing protection during extended periods of operation.
 - **SECURE WORK.** Use clamps or a vise to hold work when practical. It's safer than using your hand and it frees both hands to operate tool.
 - **DO NOT OVERREACH.** Keep proper footing and balance at all times.
 - **MAINTAIN TOOLS WITH CARE.** Keep tools sharp and clean for better and safer performance. Follow instructions for lubricating and changing accessories.
 - **DISCONNECT ALL TOOLS.** When not in use, before servicing, or when changing attachments, blades, bits, cutters, etc., all tools should be disconnected.
 - **AVOID ACCIDENTAL STARTING.** Be sure switch is off when plugging in.
 - **USE RECOMMENDED ACCESSORIES.** The use of improper accessories may cause risk of injury.
 - **NEVER STAND ON TOOL.** Serious injury could occur if the tool is tipped or if the blade is unintentionally contacted.
 - **CHECK DAMAGED PARTS.** Before further use of the tool, a guard or other part that is damaged should be carefully checked to determine that it will operate properly and perform its intended function. Check for alignment of moving parts, binding of moving parts, breakage of parts, mounting and any other conditions that may affect its operation. A guard or other part that is damaged must be properly repaired or replaced by a qualified service technician at a Sears store to avoid risk of personal injury.
 - **NEVER LEAVE TOOL RUNNING UNATTENDED. TURN THE POWER OFF.** Do not leave tool until it comes to a complete stop.
 - **FIRMLY CLAMP OR BOLT** your miter saw to a workbench or table at approximately hip height.
 - **USE ONLY CORRECT BLADES.** Do not use blades with incorrect size holes. Never use blade washers or blade bolts that are defective or incorrect. The maximum blade capacity of your saw is 10 in.
 - **KEEP BLADES CLEAN, SHARP AND WITH SUFFICIENT SET.** Sharp blades minimize stalling and kickback.
 - **DO NOT REMOVE THE SAW'S BLADE GUARDS.** Never operate the saw with any guard or cover removed. Make sure all guards are operating properly before each use.
 - **KEEP HANDS AWAY FROM CUTTING AREA.** Keep hands away from blades. Do not reach underneath work or around or under the blade while blade is rotating. Do not attempt to remove cut material when blade is moving.
-  **WARNING:** Blade coasts after turn off.
- **DO NOT ABUSE CORD.** Never yank cord to disconnect it from receptacle. Keep cord from heat, oil, and sharp edges.
 - **INSPECT TOOL CORDS PERIODICALLY** and if damaged, have repaired by a qualified service technician at a Sears store. Stay constantly aware of cord location and keep it well away from the rotating blade.
 - **USE OUTDOOR EXTENSION CORDS.** When tool is used outdoors, use only extension cords with approved ground connection that are intended for use outdoors and so marked.
 - **DO NOT USE TOOL IF SWITCH DOES NOT TURN IT ON AND OFF.** Have defective switches replaced by a qualified service technician at a Sears store.
 - **KEEP TOOL DRY, CLEAN, AND FREE FROM OIL AND GREASE.** Always use a clean cloth when cleaning. Never use brake fluids, gasoline, petroleum-based products, or any solvents to clean tool.

RULES FOR SAFE OPERATION (Continued)

- **ALWAYS SUPPORT LONG WORKPIECES** to minimize risk of blade pinching and kickback. Saw may slip, walk, or slide while cutting long or heavy boards.
 - **BEFORE MAKING A CUT, BE SURE ALL ADJUSTMENTS ARE SECURE.**
 - **GUARD AGAINST KICKBACK.** Kickback occurs when the blade stalls rapidly and workpiece is driven back towards the operator. It can pull your hand into the blade resulting in serious personal injury. Stay out of blade path and turn switch off immediately if blade binds or stalls.
 - **AVOID CUTTING NAILS.** Inspect for and remove all nails from lumber before cutting.
 - **ALWAYS USE A CLAMP** to secure the workpiece when possible.
 - **NEVER TOUCH BLADE** or other moving parts during use.
 - **NEVER START A TOOL WHEN THE BLADE IS IN CONTACT WITH WORKPIECE.** Allow motor to come up to full speed before starting cut.
 - **MAKE SURE THE MITER TABLE AND SAW ARM (BEVEL FUNCTION) ARE LOCKED IN POSITION BEFORE OPERATING YOUR SAW.** Lock the miter table by securely tightening the miter lock handle. Lock the saw arm (bevel function) by securely tightening the bevel lock knob.
 - **NEVER USE A LENGTH STOP ON THE FREE SCRAP END OF A CLAMPED WORKPIECE.** NEVER hold onto or bind the free scrap end of the workpiece in any operation. If a work clamp and length stop are used together, they must both be installed on the same side of the saw table to prevent the saw from catching the loose end and kicking up.
 - **NEVER** cut more than one piece at a time. **DO NOT STACK** more than one workpiece on the saw table at a time.
 - **NEVER PERFORM ANY OPERATION "FREE-HAND".** Always place the workpiece to be cut on the miter table and position it firmly against the fence as a backstop. Always use the fence.
 - **NEVER** hand hold a workpiece that is too small to be clamped. Keep hands clear of the no hands zone.
 - **NEVER** reach behind, under, or within three inches of the blade and its cutting path with your hands and fingers for any reason.
 - **NEVER** reach to pick up a workpiece, a piece of scrap, or anything else that is in or near the cutting path of the blade.
 - **AVOID AWKWARD OPERATIONS AND HAND POSITIONS** where a sudden slip could cause your hand to move into the blade. **ALWAYS** make sure you have good balance. **NEVER** operate your miter saw on the floor or in a crouched position.
 - **NEVER** stand or have any part of your body in line with the path of the saw blade.
 - **ALWAYS** release the power switch and allow the saw blade to stop rotating before raising it out of the workpiece.
 - **DO NOT TURN THE MOTOR SWITCH ON AND OFF RAPIDLY.** This could cause the saw blade to loosen and could create a hazard. Should this ever occur, stand clear and allow the saw blade to come to a complete stop. Disconnect your saw from the power supply and securely retighten the blade bolt.
 - **REPLACEMENT PARTS.** All repairs, whether electrical or mechanical, should be made by qualified service technician at a Sears store.
-  **WARNING:** When servicing use only identical Craftsman replacement parts. Use of any other parts may create a hazard or cause product damage.
- **NEVER USE IN AN EXPLOSIVE ATMOSPHERE.** Normal sparking of the motor could ignite fumes.
 - **NEVER** leave the miter saw unattended while connected to a power source.
 - **POLARIZED PLUGS.** To reduce the risk of electric shock, this tool has a polarized plug (one blade is wider than the other). This plug will fit in a polarized outlet only one way. If the plug does not fit fully in the outlet, reverse the plug. If it still does not fit, contact a qualified electrician to install the proper outlet. Do not change the plug in any way.
 - **IF ANY PART OF THIS MITER SAW IS MISSING** or should break, bend, or fail in any way, or should any electrical component fail to perform properly, shut off the power switch, remove the miter saw plug from the power source and have damaged, missing, or failed parts replaced before resuming operation.
 - **DO NOT OPERATE THIS TOOL WHILE UNDER THE INFLUENCE OF DRUGS, ALCOHOL, OR ANY MEDICATION.**

RULES FOR SAFE OPERATION (Continued)

- **ALWAYS STAY ALERT!** Do not allow familiarity (gained from frequent use of your saw) to cause a careless mistake. **ALWAYS REMEMBER** that a careless fraction of a second is sufficient to inflict severe injury.
- **STAY ALERT AND EXERCISE CONTROL.** Watch what you are doing and use common sense. **Do not operate tool when you are tired. Do not rush.**
- **MAKE SURE THE WORK AREA HAS AMPLE LIGHTING** to see the work and that no obstructions will interfere with safe operation **BEFORE** performing any work using your saw.
- **ALWAYS TURN OFF SAW** before disconnecting it, to avoid accidental starting when re-connecting to power supply.
- **SAVE THESE INSTRUCTIONS.** Refer to them frequently and use to instruct other users. If you loan someone this tool, loan them these instructions also.

SAVE THESE INSTRUCTIONS

GLOSSARY OF TERMS FOR WOODWORKING

Arbor

The shaft on which a blade or cutting tool is mounted.

Bevel Cut

A cutting operation made with the blade at any angle other than 90° to the miter table.

Crosscut

A cutting or shaping operation made across the grain of the workpiece.

Compound Miter Cut

A compound miter cut is a cut made using a miter angle and a bevel angle at the same time.

Freehand

Performing a cut without using a fence, miter gage, fixture, work clamp, or other proper device to keep the workpiece from twisting or moving during the cut.

Gum

A sticky, sap based residue from wood products.

Miter Cut

A cutting operation made with the blade at any angle other than 90° to the fence.

Resin

A sticky, sap base substance that has hardened.

Revolutions Per Minute (RPM)

The number of turns completed by a spinning object in one minute.

Saw Blade Path

The area over, under, behind, or in front of the blade. As it applies to the workpiece, that area which will be, or has been, cut by the blade.

Set

The distance that the tip of the sawblade tooth is bent (or set) outward from the face of the blade.

Throw-Back

Throwing of a workpiece in a manner similar to a kickback. Usually associated with a cause other than the kerf closing, such as a workpiece not being against the fence, being dropped into the blade, or being placed inadvertently in contact with the blade.

Through Sawing

Any cutting operation where the blade extends completely through the thickness of the workpiece.

Workpiece

The item on which the cutting operation is being done. The surfaces of a workpiece are commonly referred to as faces, ends, and edges.

Zero Clearance Throat Plate

A plastic throat plate inserted in the miter table that allows for blade clearance. When you make your first cut with your compound miter saw, the saw blade cuts a slot through the throat plate the exact width of the blade. This provides for a zero clearance kerf that minimizes workpiece tear-out.

No Hands Zone

The area between the marked lines on the left and right side of the miter table base. This zone is identified by no hands zone labels placed inside the marked lines on the miter table base.

PRODUCT SPECIFICATIONS

| | | |
|----------------|--------------------------|---|
| Blade Diameter | 10 in. | Cutting Capacity with Miter at 0°/Bevel 0°: |
| Blade Arbor | 5/8 in. | 5-9/16 in. wide X 2-9/32 in. thick |
| No Load Speed | 5000 RPM | 3-9/16 in. thick X 4 in. wide |
| Rating | 120 Volts, 60 Hz-AC Only | Maximum Cutting Capacity with Miter at 45°/Bevel 0°: |
| Input | 15 Amperes | 3-15/16 in. wide X 2-9/32 in. thick |
| Net Weight | 32 lbs. | Maximum Cutting Capacity with Miter at 0°/Bevel 45°: |
| | | 5-9/16 in. wide X 1-9/16 in. thick |
| | | Maximum Cutting Capacity with Miter at 45°/Bevel 45°: |
| | | 4 in. wide X 1-9/16 in. thick |

UNPACKING

Your Compound Miter Saw has been shipped completely assembled except for the blade, miter lock handle, and dust guide.

⚠ WARNING: If any parts are missing, do not operate this tool until the missing parts are replaced. Failure to do so could result in possible serious personal injury.

- Remove all loose parts from the carton. Separate and check with the list of loose parts. *See Figure 2.*
- Remove the packing materials from around your saw.
- Carefully lift saw from the carton and place it on a level work surface. This saw is heavy. To avoid back injury, get help when needed.

- Do not discard the packing materials until you have carefully inspected the saw, identified all loose parts, and satisfactorily operated your new saw.
- Your saw has been shipped with the saw arm locked in the down position. To release saw arm, push down on top of saw arm and pull out the lock pin. *See Figure 4.*
- Lift the saw arm by the handle. Hand pressure should remain on the saw arm to prevent sudden rise upon release of the lock pin.
- Examine all parts to make sure no breakage or damage has occurred during shipping.

If any parts are damaged or missing, do not attempt to plug in the power cord and turn the switch on until the damaged or missing parts are obtained and are installed correctly.

LABELS

The following labels are on the miter saw with locations indicated.

Restore lower blade guard and securely tighten screw before use

Lift For Blade Change. See Owner's Manual.

DANGER: DO NOT REMOVE ANY GUARD. USE OF SAW WITHOUT THIS GUARD WILL RESULT IN SERIOUS INJURY.

⚠ WARNING / ADVERTENCIA

- For your safety, read owners manual before operating miter saw.
- Wear eye protection.
- Keep hands out of path of saw blade.
- Do not operate saw without guards in place.
- Do not perform any operation freehand.
- Never reach around the saw blade.
- Turn off tool and wait for saw blade to stop before moving workpiece or changing settings.
- Disconnect the saw from the power source before changing blade or servicing.
- Do not expose to rain or use in damp places.
- Para su seguridad, lea el manual del usuario antes de usar la sierra ingletadora.

10 inch Compound Miter Saw

DOUBLE INSULATED 5,000 RPM 120 VOLTS 60 Hz AC ONLY 15 A

WARNING: WHEN SERVICING, USE ONLY IDENTICAL CRAFTSMAN REPLACEMENT PARTS.

MODEL 315.243000
MADE IN TAIWAN
SEARS, ROEBUCK AND CO.

SER. NO.



Customer Help Line 1-800-932-3188

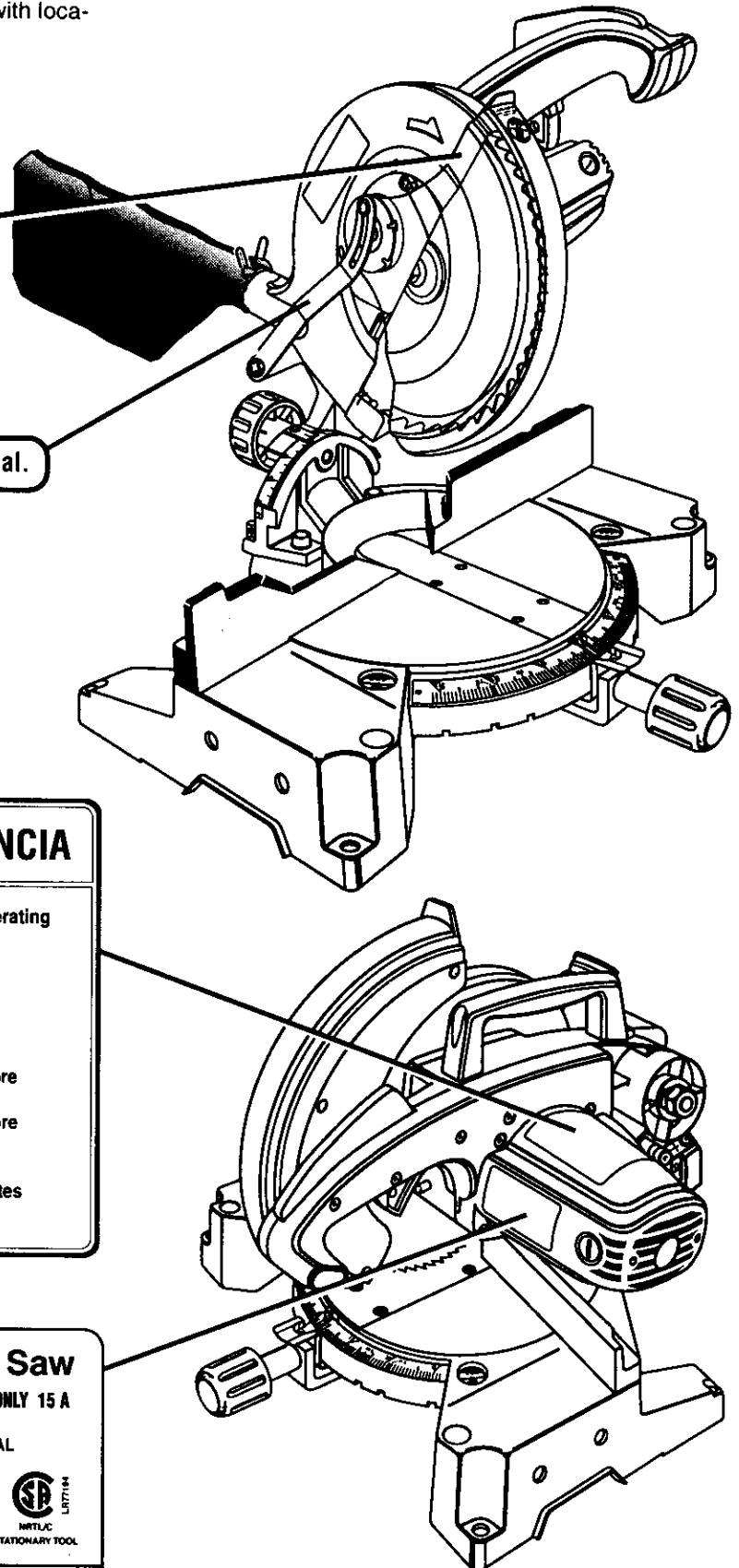

Fig. 1

LOOSE PARTS LIST

The following items are included with your Compound Miter Saw:

- Saw Blade - 10 in.
- Miter Lock Handle
- Dust Guide
- Dust Bag
- Blade Wrench
- 5 mm Hex Key Wrench
- 6 mm Hex Key Wrench
- 8 mm Hex Key Wrench
- Owner's Manual

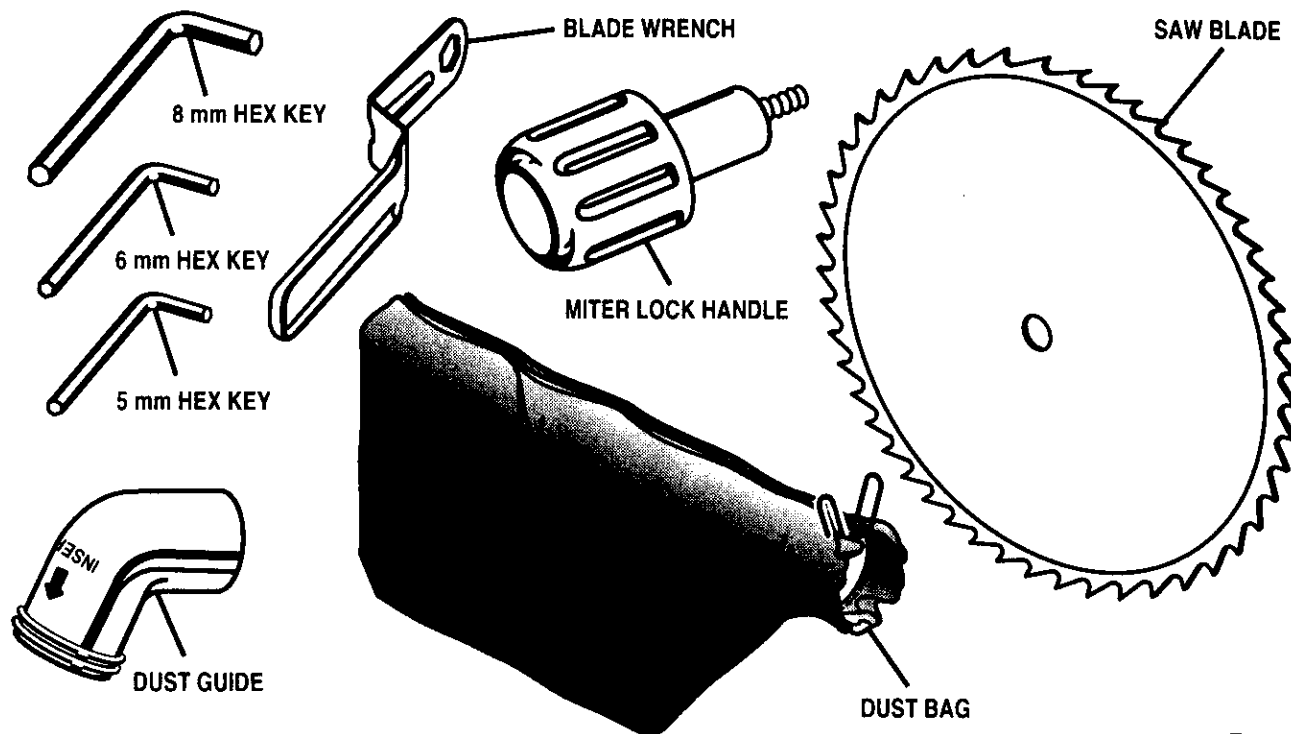
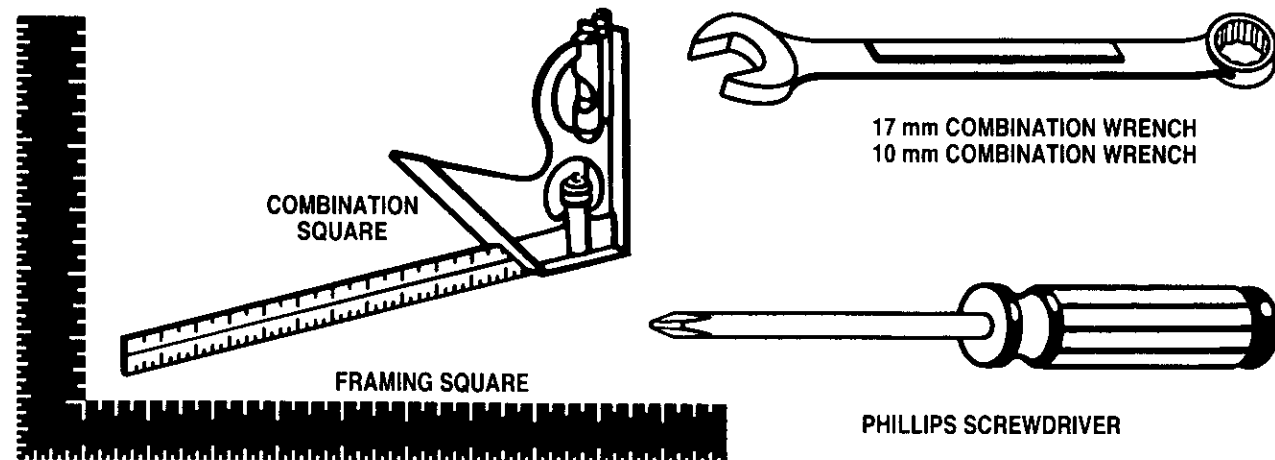

Fig. 2

⚠ WARNING: The use of attachments or accessories not listed might be hazardous and could cause serious personal injury.

TOOLS NEEDED

The following tools (not included) are needed for checking adjustments of your saw or for installing the blade:



FEATURES

KNOW YOUR COMPOUND MITER SAW

See Figure 3.

Before attempting to use your saw, familiarize yourself with all operating features and safety requirements.

⚠ WARNING: Do not allow familiarity with your saw to make you careless. Remember that a careless fraction of a second is sufficient to inflict severe injury.

15 AMP MOTOR

Your saw has a powerful 15 amp motor with sufficient power to handle tough cutting jobs. It is made with all ball bearings, and has externally accessible brushes for ease of servicing.

10 in. BLADE

A 10 in. saw blade is included with your compound miter saw. It will cut materials up to 2-5/8 in. thick or 5-3/4 in. wide, depending upon the thickness of the material and the setting at which the cut is being made.

ELECTRIC BRAKE

An electric brake has been provided to quickly stop blade rotation after the switch is released.

FENCE

The fence on your compound miter saw has been provided to hold your workpiece securely against when making all cuts.

SELF-RETRACTING LOWER BLADE GUARD

The lower blade guard is made of shock-resistant, see-through plastic that provides protection from each side of the blade. It retracts over the upper blade guard as the saw is lowered into the workpiece.

MITER LOCK HANDLE

See Figure 4.

The miter lock handle securely locks your saw at desired miter angles.

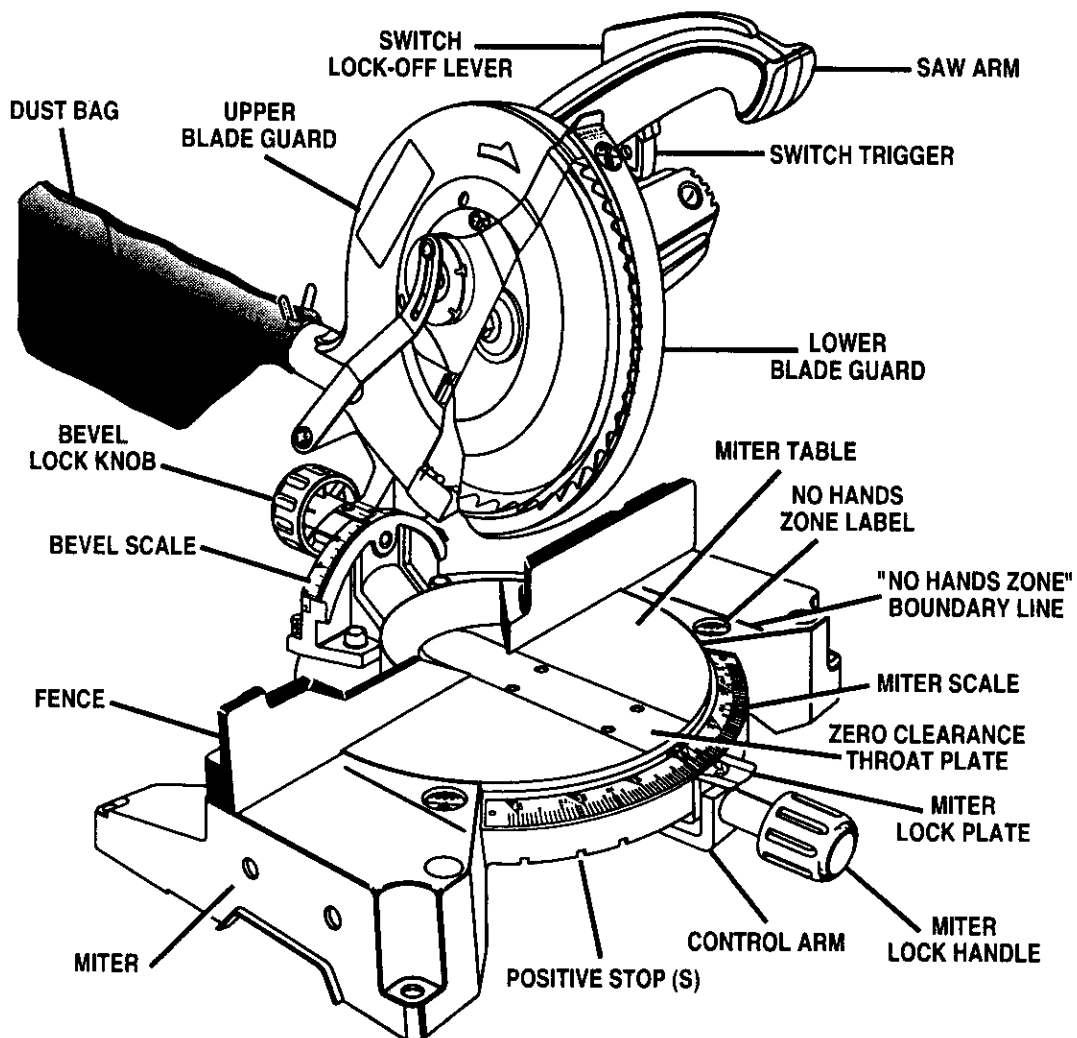

Fig. 3

FEATURES

CARRYING HANDLE

See Figure 4.

For convenience when carrying or transporting your miter saw from one place to another, a carrying handle has been provided on top of the saw arm as shown in figure 4. To transport, turn off and unplug your saw, then lower the saw arm and lock it in the down position. Lock saw arm by depressing the lock pin.

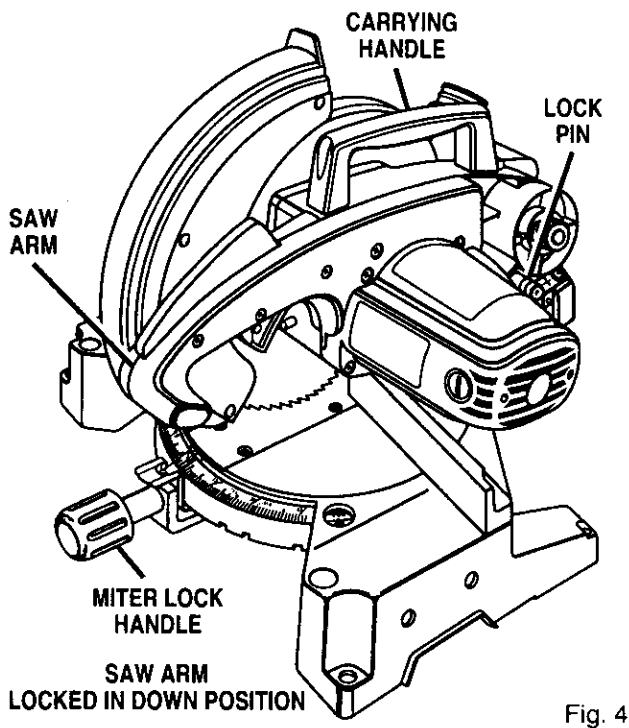

Fig. 4

POSITIVE STOPS ON MITER TABLE

Positive stops have been provided at 0°, 22-1/2° and 45°. The 22-1/2° and 45° positive stops have been provided on both the left and right side of the miter table.

BEVEL LOCK KNOB

The bevel lock knob securely locks your compound miter saw at desired bevel angles. Positive stop adjustment screws have been provided on each side of the saw arm. These adjustment screws are for making fine adjustments at 0° and 45°. See pages 18 and 19.

LOCK-OFF LEVER

See Figure 5.

The switch trigger is equipped with a lock-off lever to reduce the possibility of accidental starting. The lock-off lever must be pressed down with the palm of your hand to turn saw on. Once the saw is on, the lock-off lever can be released. The spring loaded lever will spring back into the lock-off position when the switch trigger is released.

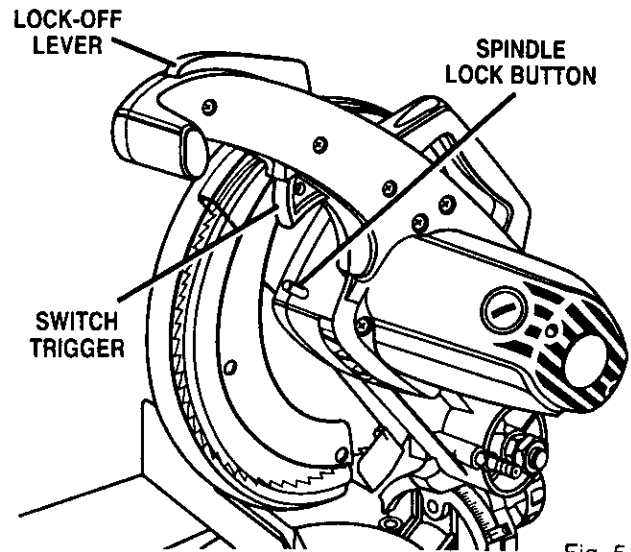

Fig. 5

SPINDLE LOCK BUTTON

See Figure 5.

A spindle lock button has been provided for locking the spindle which stops the rotation of the blade in your saw. Depress and hold the lock button while installing, changing, or removing blade.

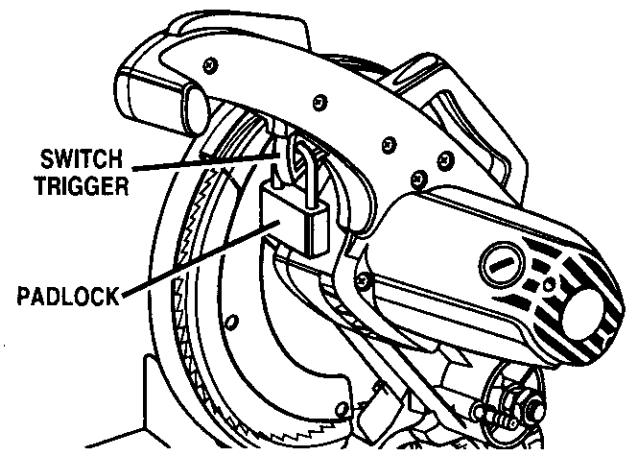

Fig. 6

TRIGGER LOCK

See Figure 6.

To prevent unauthorized use of your compound miter saw, we suggest that you disconnect it from the power supply and lock the switch in the off position. To lock the switch, install a padlock through the hole in the switch trigger. A lock with a shackle up to 13/64 in. diameter may be used. When the lock is installed and locked, the switch is inoperable. Store the padlock key in another location.

FEATURES

MOUNTING HOLES

See Figure 7.

Your compound miter saw should be permanently mounted to a firm supporting surface such as workbench. Four 7/16 in. bolt holes have been provided in the saw base for this purpose. Each of the four mounting holes should be bolted securely using 3/8 in. machine bolts, lock washers, and hex nuts (not included). Bolts should be of sufficient length to accommodate the saw base, lock washers, hex nuts, and the thickness of the workbench.

Tighten all four bolts securely.

The hole pattern for an 18 in. x 24 in. workbench is shown in Figure 7. Carefully check the workbench after mounting to make sure that no movement can occur during use. If any tipping, sliding, or walking is noted, secure the workbench to the floor before operating.

⚠ WARNING: Always make sure your compound miter saw is securely mounted to a workbench or an approved workstand. Failure to do so could result in an accident resulting in possible serious personal injury.

ELECTRICAL CONNECTION

Your saw has a precision built electric motor. It should be connected to a **power supply that is 120 volts, 60 Hz, AC only (normal household current)**. Do not operate this tool on direct current (DC). A substantial voltage drop will cause a loss of power and the motor will overheat. If your tool does not operate when plugged into an outlet, double-check the power supply.

⚠ WARNING: To prevent accidental starting that could cause possible serious personal injury, assemble all parts to your saw before connecting it to power supply. Saw should never be connected to power supply when you are assembling parts, making adjustments, installing or removing blades, or when not in use.

As mentioned previously your saw has been factory assembled and adjusted. The miter lock handle, dust guide, and blade are the only parts that have to be installed.

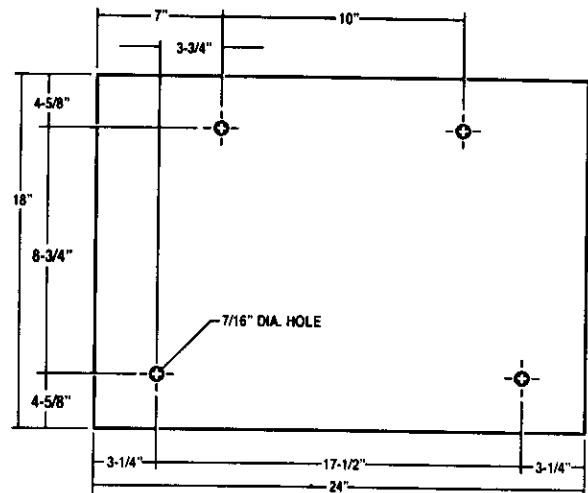

Fig. 7

⚠ WARNING: The operation of any saw can result in foreign objects being thrown into your eyes, which can result in severe eye damage. Before starting power tool operation, always wear safety goggles or safety glasses with side shields and a full face shield when needed. We recommend wide vision safety mask for use over eyeglasses or standard safety glasses with side shields.

⚠ WARNING: Do not attempt to modify this tool or create accessories not recommended for use with this tool. Any such alteration or modification is misuse and could result in a hazardous condition leading to possible serious personal injury.

ADJUSTMENTS

MITER LOCK HANDLE

See Figure 8.

To install the miter lock handle, place the threaded stud on the end of the miter lock handle into the threaded hole in the control arm. Turn clockwise to tighten.

ADJUSTMENTS

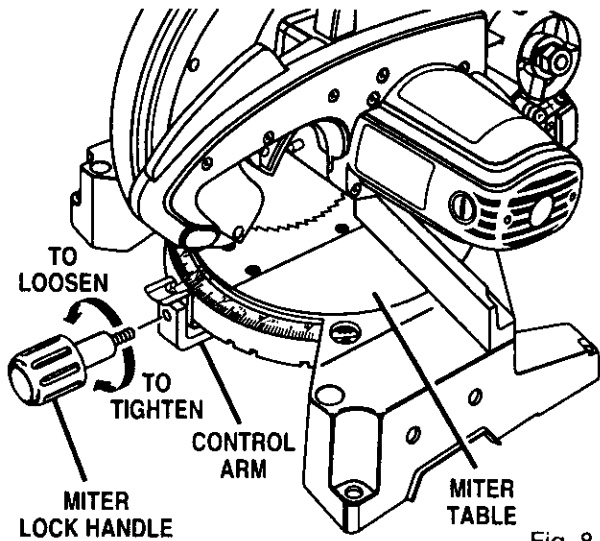

Fig. 8

DUST GUIDE

See Figure 9.

To install the dust guide, place the end marked **INSERT** over the exhaust port in the upper blade guard. Turn the guide so that the open end is facing down or toward the rear of the saw.

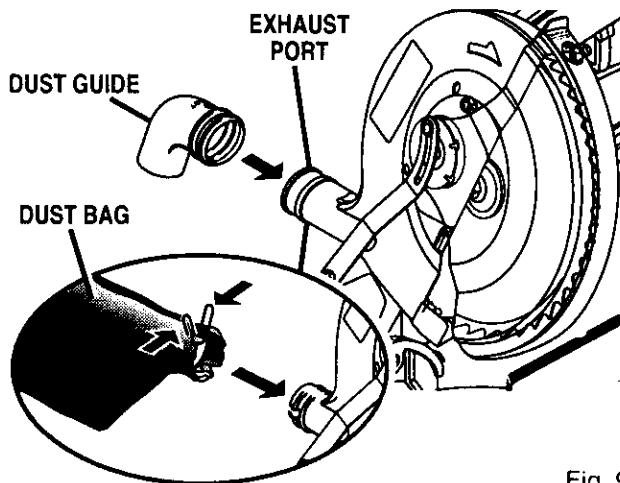

Fig. 9

DUST BAG

See Figure 9.

The dust bag fits over the exhaust port on the upper blade guard. To install the dust bag, remove the dust guide from the exhaust port. Then, squeeze the two metal clips to open the mouth of the bag and slide the bag on the exhaust port. Release the clips. The metal ring in the bag should lock in between the grooves on the exhaust port. For more efficient operation, empty the dust bag when no more than half full. This will permit better air flow through the bag.

TO INSTALL BLADE

See Figures 10, 11, and 12.

WARNING: A 10 in. blade is the maximum blade capacity of your saw. Never use a blade that is too thick to allow outer blade washer to engage with the flats on the spindle. Larger blades will come in contact with the blade guards, while thicker blades will prevent the blade screw from securing the blade on the spindle. Either of these situations could result in a serious accident and can cause serious personal injury.

■ Unplug your saw.

WARNING: Failure to unplug your saw could result in accidental starting causing possible serious personal injury.

■ Push down on the saw arm and pull out the lock pin to release saw arm. Raise saw arm to its full raised position. Be cautious, saw arm is spring loaded to raise.

■ Loosen the phillips screw on the blade bolt cover until blade bolt cover can be raised. See Figure 10 and 11.

■ Gently raise the lower blade guard bracket, releasing lower blade guard from notch so that lower blade guard and blade bolt cover can be rotated up and back to expose the blade bolt. See Figures 10 and 11.

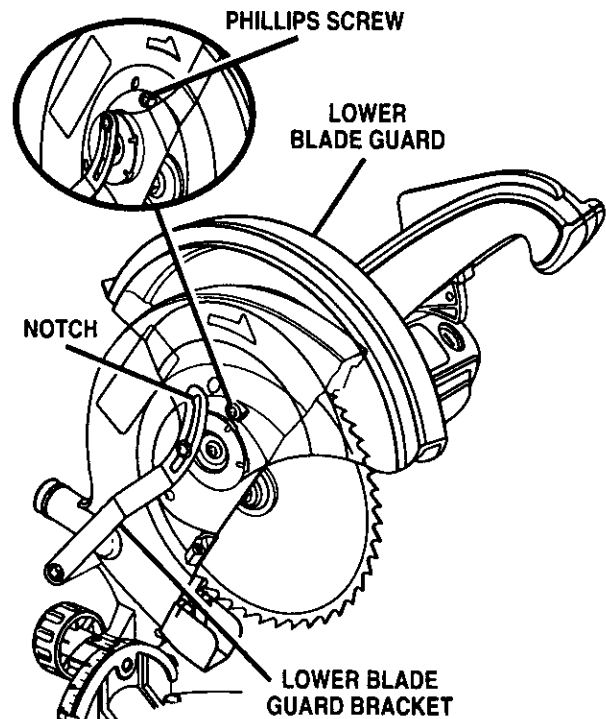

Fig. 10

ADJUSTMENTS

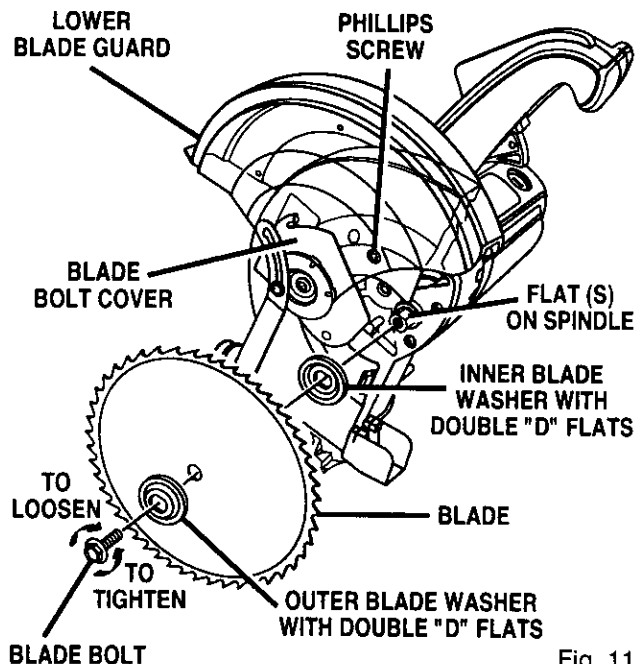

Fig. 11

- Depress the spindle lock button and rotate the blade bolt until the spindle locks. *See Figure 12.*
- Using the blade wrench provided, loosen and remove the blade bolt.
Note: The blade bolt has left hand threads. Turn blade bolt clockwise to loosen.
- Remove outer blade washer. **Do not** remove inner blade washer.

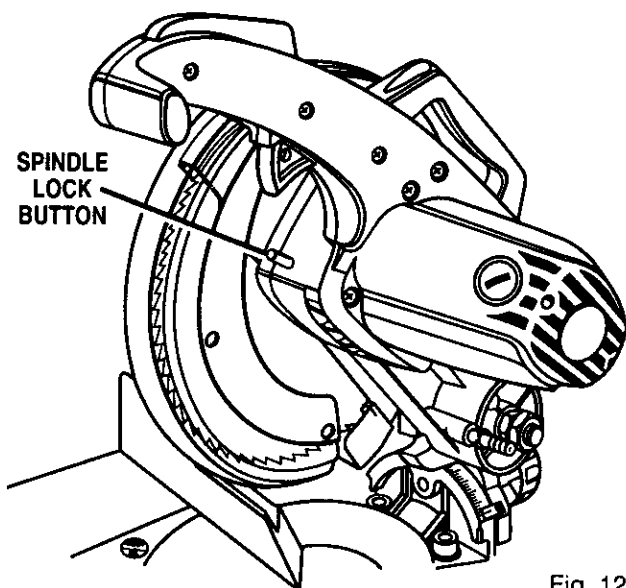

Fig. 12

- Wipe a drop of oil onto inner blade washer and outer blade washer where they contact the blade.
- ⚠ **WARNING:** If inner blade washer has been removed, replace it before placing blade on spindle. Failure to do so could cause an accident since blade will not tighten properly.
- Fit saw blade inside lower blade guard and onto spindle. The blade teeth point downward at the front of saw as shown in figure 11.
- ⚠ **CAUTION:** Always install the blade with the blade teeth and the arrow printed on the side of the blade pointing down at the front of the saw. The direction of blade rotation is also stamped with an arrow on the upper blade guard.
- Replace outer blade washer. The double "D" flats on the blade washers align with the flats on the spindle.
- Depress spindle lock button and replace blade bolt.
Note: The blade bolt has left hand threads. Turn blade bolt counterclockwise to tighten.
- Tighten blade bolt securely.
- Remove the blade wrench and store it in a safe place for future use.
- Replace the lower blade guard and blade bolt cover.
- Retighten phillips screw securing blade bolt cover. Tighten screw securely. *See Figure 11.*

⚠ **WARNING:** Make sure the spindle lock button is not engaged before reconnecting saw into power source. Never engage spindle lock button when blade is rotating.

Your compound miter saw has been adjusted at the factory for making very accurate cuts. However, some of the components might have been jarred out of alignment during shipping. Also, over a period of time, readjustment will probably become necessary due to wear. After unpacking your saw, check the following adjustments before you begin using saw. Make any readjustments that are necessary and periodically check the parts alignment to make sure that your saw is cutting accurately.

⚠ **WARNING:** Your saw should never be connected to power supply when you are assembling parts, making adjustments, installing or removing blades, or when not in use. Disconnecting your saw will prevent accidental starting that could cause serious injury.

ADJUSTMENTS

Note: Many of the illustrations in this manual show only portions of your compound miter saw. This is intentional so that we can clearly show points being made in the illustrations. Never operate your saw without all guards securely in place and in good operating condition.

CUTTING A SLOT IN THE ZERO CLEARANCE THROAT PLATE

In order to use your compound miter saw, you must cut a slot through the zero clearance throat plate to allow for blade clearance. To cut the slot, set your saw at 0 degrees miter, turn saw on and allow the blade to reach full speed, then carefully make a straight cut as far as it will go through the throat plate. Turn your saw off and allow the blade to come to a complete stop before raising the saw arm.

Next, adjust the bevel angle to 45 degrees, turn your saw on and allow the blade to reach full speed, then carefully make another cut through the zero clearance throat plate. The throat plate will then be wide enough to allow the blade to pass through it at any angle from 0 to 45 degrees.

SQUARING THE MITER TABLE TO THE FENCE

See Figures 13 - 16.

- Unplug your saw.

WARNING: Failure to unplug your saw could result in accidental starting causing possible serious personal injury.

- Push down on the saw arm and pull out the lock pin to release the saw arm.
- Raise saw arm to its full raised position.
- Loosen the miter lock handle approximately one-half turn.
- Depress the miter lock plate and rotate the miter table until the pointer on the control arm is positioned at 0°.
- Release the miter lock plate and securely tighten the miter lock handle.
- Lay a framing square flat on the miter table. Place one leg of the square against the fence. Place the other leg of the square beside the zero clearance throat plate in the miter table. The edge of the square and the zero clearance throat plate in the miter table should be parallel as shown in figure 13.
- If the edge of the framing square and the zero clearance throat plate in the miter table are not parallel as shown in figures 14 and 15, adjustments are needed.

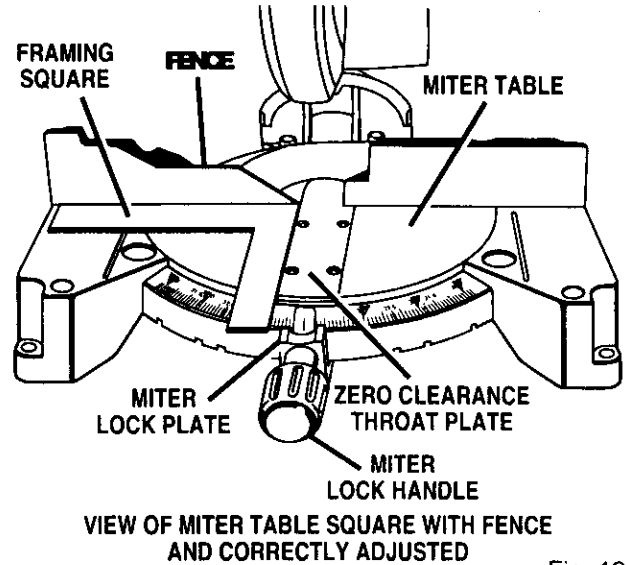

Fig. 13

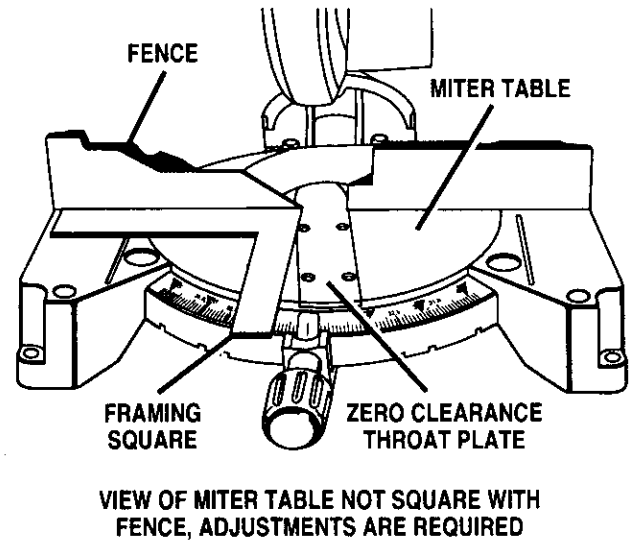

Fig. 14

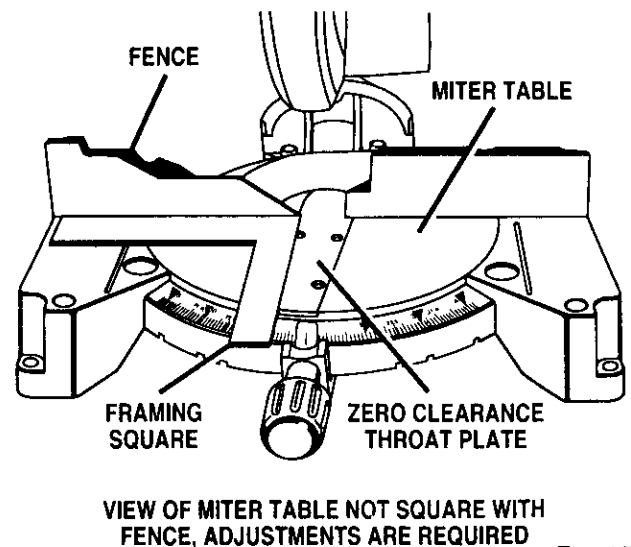

Fig. 15

ADJUSTMENTS

- Using a 6 mm key, loosen the socket head screws securing the fence. See Figure 16. Adjust the fence left or right until the framing square and zero clearance throat plate are parallel.
- Retighten the screws securely and recheck the fence-to-table alignment.

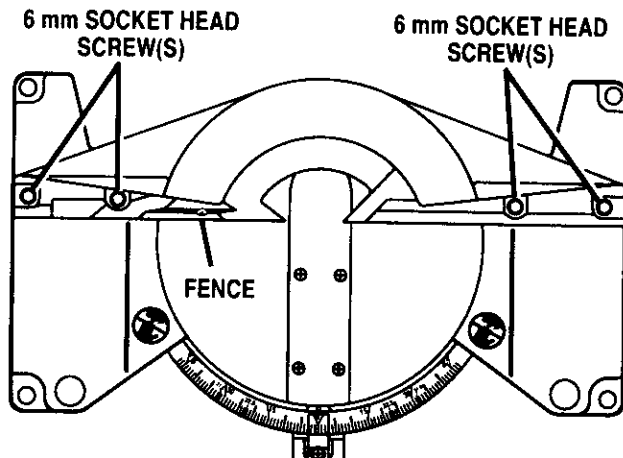

Fig. 16

SQUARING THE SAW BLADE TO THE FENCE

See Figures 17 - 20.

- Unplug your saw.

⚠ WARNING: Failure to unplug your saw could result in accidental starting causing possible serious personal injury.

- Pull the saw arm all the way down and engage the lock pin to hold the saw arm in transport position.
- Loosen the miter lock handle approximately one-half turn.
- Depress the miter lock plate and rotate the miter table until the pointer on the control arm is positioned at 0°.
- Release the miter lock plate and securely tighten the miter lock handle.
- Lay a framing square flat on the miter table. Place one leg of the square against the fence. Slide the other leg of the square against the flat part of saw blade.

Note: Make sure that the square contacts the flat part of the saw blade, not the blade teeth.

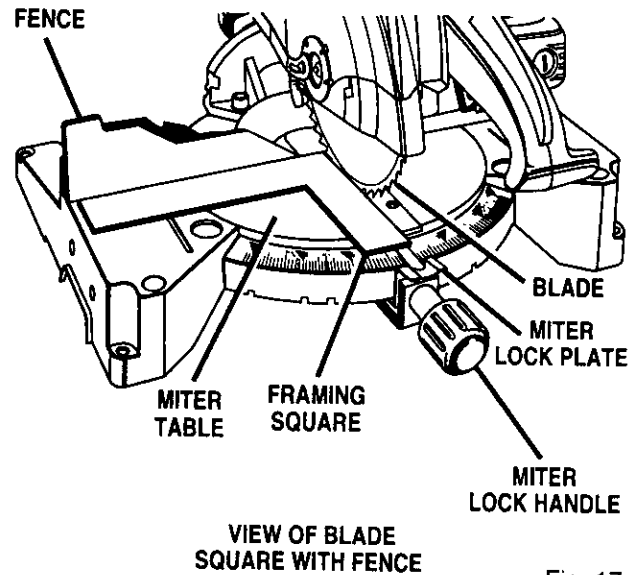

Fig. 17

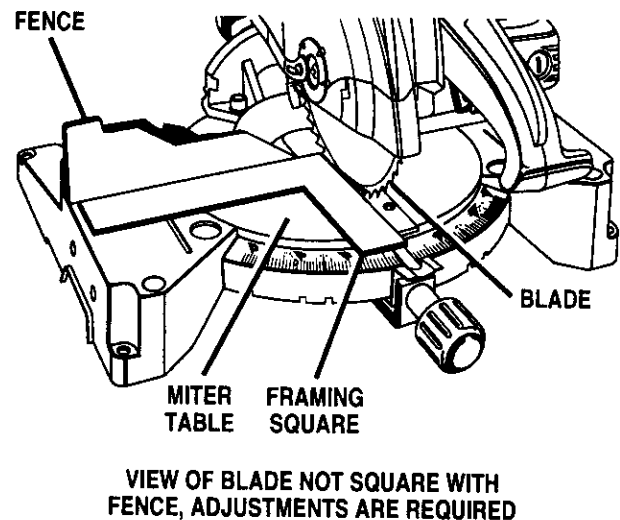
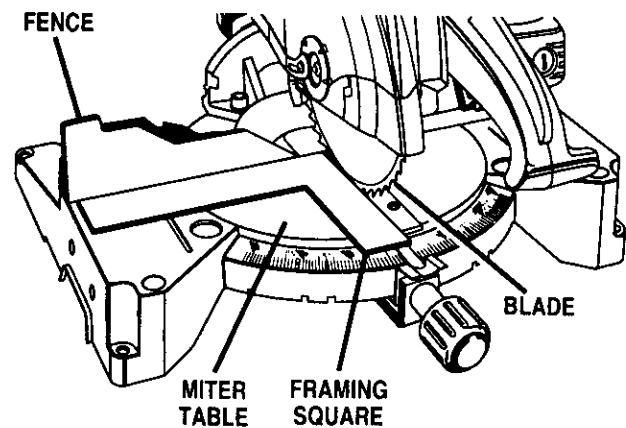

Fig. 18



VIEW OF BLADE NOT SQUARE WITH FENCE, ADJUSTMENTS ARE REQUIRED

Fig. 19

ADJUSTMENTS

- The edge of the square and the saw blade should be parallel as shown in figure 17.
- If the front or back edge of the saw blade angles away from the square as shown in figures 18 and 19, adjustments are needed.
- Using the 8 mm hex key provided, loosen the socket head screws that secure the mounting bracket to the miter table. See Figure 20.

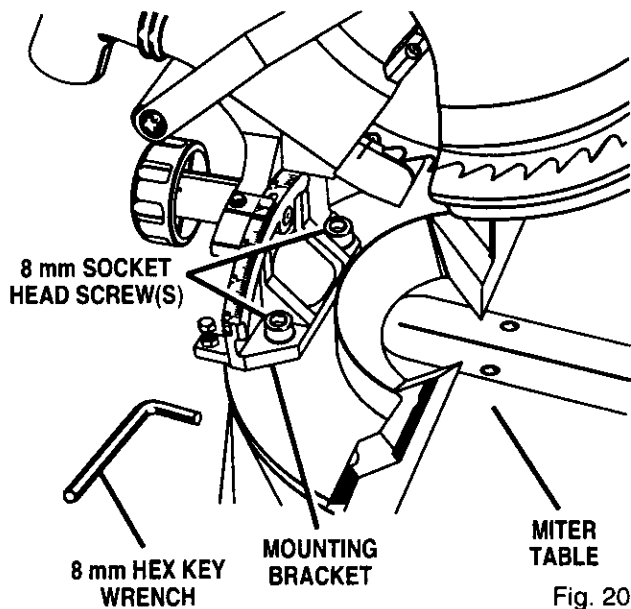

Fig. 20

- Rotate the mounting bracket left or right until the saw blade is parallel with the square.
- Retighten the screws securely and recheck the blade-to-fence alignment.

SQUARING THE BLADE TO THE MITER TABLE

See Figures 21-24.

- Unplug your saw.

⚠ WARNING: Failure to unplug your saw could result in accidental starting causing possible serious personal injury.

- Pull the saw arm all the way down and engage the lock pin to hold the saw arm in transport position.
- Loosen the miter lock handle approximately one-half turn.
- Depress the miter lock plate and rotate the miter table until the pointer on the control arm is positioned at 0°.
- Release the miter lock plate and securely tighten the miter lock handle.

- Loosen bevel lock knob and set saw arm at 0° bevel (blade set 90° to miter table). Tighten bevel lock knob.
- Place a combination square against the miter table and the flat part of saw blade.

Note: Make sure that the square contacts the flat part of the saw blade, not the blade teeth.
- Rotate the blade by hand and check the blade-to-table alignment at several points.
- The edge of the square and the saw blade should be parallel as shown in figure 21.

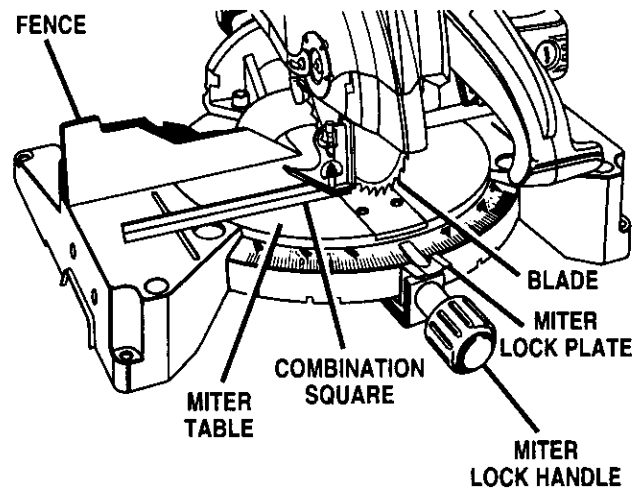

CORRECT VIEW OF BLADE SQUARE WITH MITER TABLE

Fig. 21

- If the top or bottom of the saw blade angles away from the square as shown in figures 22 and 23, adjustments are needed.

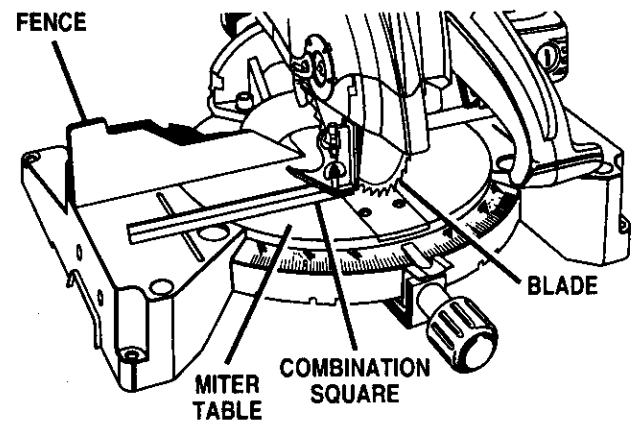

VIEW OF BLADE NOT SQUARE WITH MITER TABLE, ADJUSTMENTS ARE REQUIRED

Fig. 22

ADJUSTMENTS

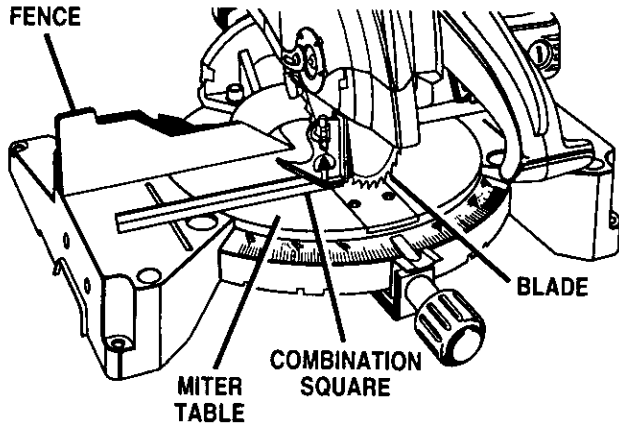

VIEW OF BLADE NOT SQUARE WITH MITER TABLE, ADJUSTMENTS ARE REQUIRED

Fig. 23

- Using a 10 mm wrench or adjustable wrench, loosen the lock nut securing positive stop adjustment screw. Also loosen bevel lock knob.
- Adjust positive stop adjustment screw to bring saw blade into alignment with the square. See Figure 24.

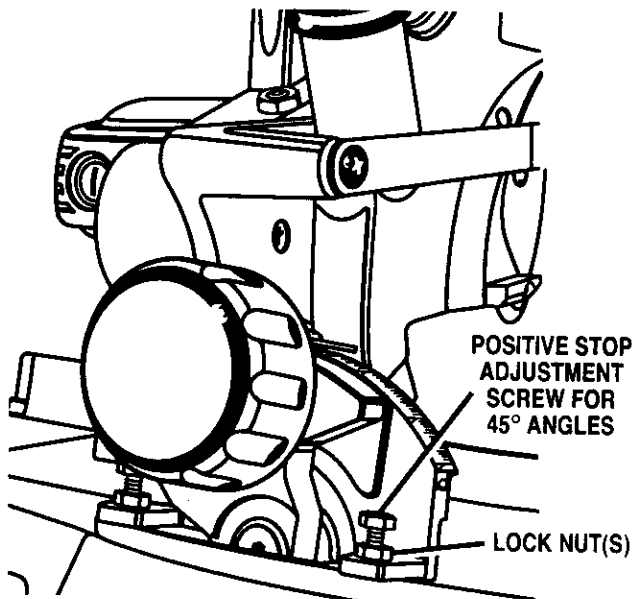

Fig. 24

- Retighten bevel lock knob. Next, retighten lock nut securing the positive stop adjustment screw. Recheck blade-to-table alignment.

Note: The above procedure can be used to check blade squareness of the saw blade to the miter table at both 0° and 45° angles.

Your saw has three scale indicators, two on either side of the bevel scale and one on the miter scale. After squaring adjustments have been made, it may be necessary to loosen the indicators screws and reset them to zero.

PIVOT ADJUSTMENTS

Note: These adjustments were made at the factory and normally do not require readjustment.

TRAVEL PIVOT ADJUSTMENT

- The saw arm should rise completely to the up position by itself.
- If the saw arm does not raise by itself or if there is play in the pivot joints, have saw repaired by a qualified service technician at your nearest Sears store to avoid risk of personal injury.

BEVEL PIVOT ADJUSTMENT

- Your compound miter saw should bevel easily by loosening the bevel lock knob and tilting the saw arm to the left.
- If movement is tight or if there is play in the pivot, have saw repaired by a qualified service technician at your nearest Sears store to avoid risk of personal injury.

DEPTH STOP

The depth stop limits the blade's downward travel. It allows the blade to go below the miter table enough to maintain full cutting capacities. The depth stop positions the blade 1/4 in. from the miter table support.

Note: The miter table support is located inside miter table.

The depth stop is factory set to provide maximum cutting capacity for the 10 in. saw blade provided with your saw. Therefore, the saw blade provided should never need adjustments.

However, when the diameter of the blade has been reduced due to sharpening, it may be necessary to adjust the depth stop to provide maximum cutting capacity. Also, when a new blade is installed, it is necessary to check the clearance of the blade to the miter table support before starting the saw. Make adjustments if needed.

DEPTH STOP ADJUSTMENTS

See Figure 25.

- Unplug your saw.

WARNING: Failure to unplug your saw could result in accidental starting causing possible serious personal injury.

- To adjust the depth stop use a 17 mm wrench or adjustable wrench and loosen the hex nut at the rear of the miter saw arm.
- Use the 5 mm hex key wrench provided to adjust the depth stop adjustment screw. The saw blade is lowered by turning the screw counter-clockwise and raised by turning the screw clockwise.

ADJUSTMENTS

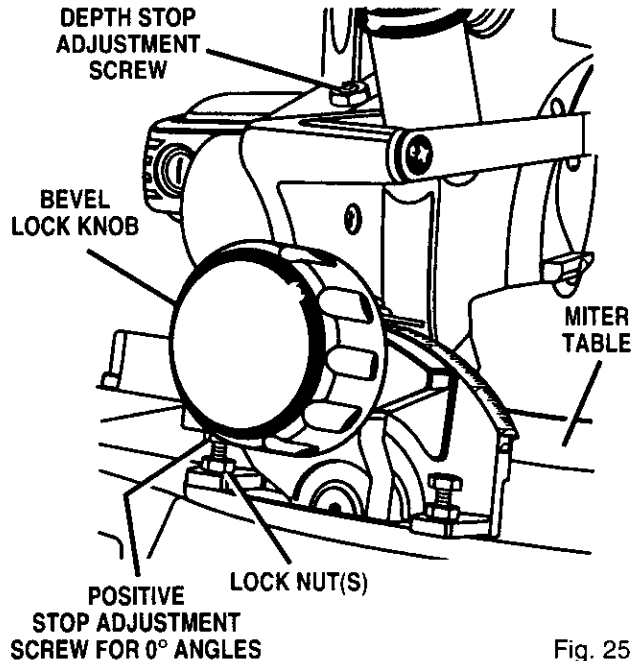

Fig. 25

- Lower the blade into the zero clearance throat plate of the miter table. Check blade clearance and maximum cutting distance (distance from fence where blade enters) to front of miter table slot.
- Readjust if necessary.

WARNING: Do not start your compound miter saw without checking for interference between the blade and the miter table support. Damage could result to the blade if it strikes the miter table support during operation of the saw.

- Tighten the hex nut with a 17 mm wrench or adjustable wrench.
- To prevent the depth stop adjustment screw from turning while tightening the hex nut, carefully hold it with the hex key wrench while tightening the hex nut.

APPLICATIONS

(Use only for the purposes listed below)

- Cross cutting wood and plastic.
- Cross cutting miters, joints, etc. for picture frames, moldings, door casings, and fine joinery.

Note: The 104 tooth crosscut blade provided is fine for most wood cutting operations, but for fine joinery cuts or cutting plastic, use one of the accessory blades available from your nearest Sears store.

WARNING: Before starting any cutting operation, clamp or bolt your compound miter saw to a workbench. Never operate your miter saw on the floor or in a crouched position. Failure to heed this warning can result in serious personal injury.

CUTTING WITH YOUR COMPOUND MITER SAW

WARNING: When using a work clamp or C-clamp to secure your workpiece, clamp workpiece on one side of the blade only. The workpiece must remain free on one side of the blade to prevent the blade from binding in workpiece. The workpiece binding the blade will cause motor stalling and kickback. This situation could cause an accident resulting in possible serious personal injury.

CROSSCUTTING

See Figure 26.

A crosscut is made by cutting across the grain of the workpiece. A straight crosscut is made with the miter table set at the zero degree position. Miter crosscuts are made with the miter table set at some angle other than zero.

TO CROSSCUT WITH YOUR MITER SAW:

- Pull out the lock pin and lift saw arm to its full height.
- Loosen the miter lock handle. Rotate the miter lock handle approximately one-half turn to the left to loosen.
- Press the miter lock plate down with your thumb and hold.
- Rotate the control arm until the pointer aligns with the desired angle on the miter scale.
- Release the miter lock plate.

Note: You can quickly locate 0°, 22-1/2° left or right, and 45° left or right by releasing the lock plate as you rotate the control arm. The lock plate will seat itself in one of the positive stop notches, located in the miter table frame.

- Tighten the miter lock handle securely.

WARNING: To avoid serious personal injury, always tighten the miter lock handle securely before making a cut. Failure to do so could result in movement of the control arm or miter table while making a cut.

OPERATION

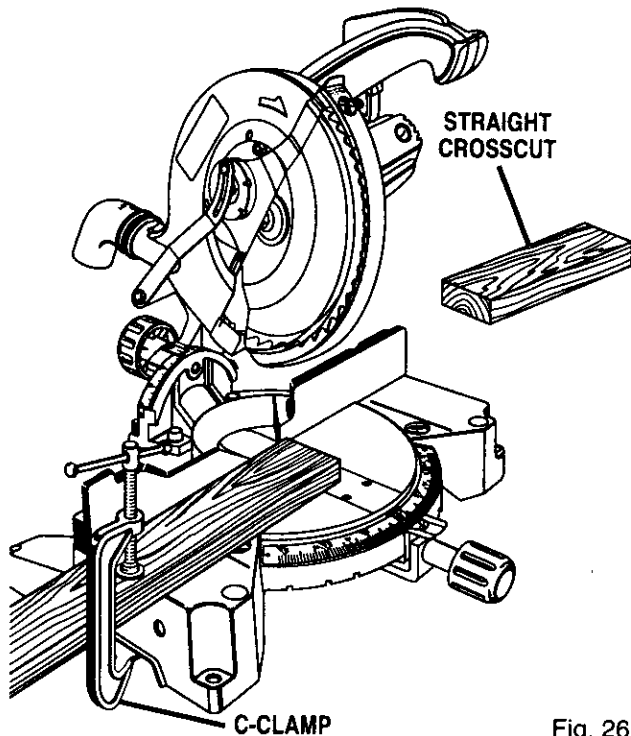

Fig. 26

- Place the workpiece flat on the miter table with one edge securely against the fence. If the board is warped, place the convex side against the fence. If the concave edge of a board is placed against the fence, the board could collapse on the blade at the end of the cut, jamming the blade. See Figures 33 and 34.
- When cutting long pieces of lumber or molding, support the opposite end of the stock with a roller stand or with a work surface level with the saw table.
- Align cutting line on the workpiece with the edge of saw blade.
- Grasp the stock firmly with one hand and secure it against the fence. Use the optional work clamp or a C-clamp to secure the workpiece when possible. See Figure 26.

⚠ WARNING: To avoid serious personal injury, keep your hands outside the no hands zone; at least 3 in. from blade. Never perform any cutting operation freehand (without holding workpiece against the fence). The blade could grab the workpiece if it slips or twists.

- Before turning on the saw, perform a dry run of the cutting operation just to make sure that no problems will occur when the cut is made.
- Grasp the saw handle firmly, press the lock-off tab down, then squeeze the switch trigger. Allow several seconds for the blade to reach maximum speed.

- Slowly lower the blade into and through the workpiece. See Figure 26.
- Release the switch trigger and allow the saw blade to stop rotating before raising the blade out of workpiece. Wait until the electric brake stops blade from turning before removing the workpiece from the miter table.

BEVEL CUT

See Figures 27 and 28.

A bevel cut is made by cutting across the grain of the workpiece with the blade angled to the workpiece. A straight bevel cut is made with the miter table set at the zero degree position and the blade set at an angle between 0° and 45°.

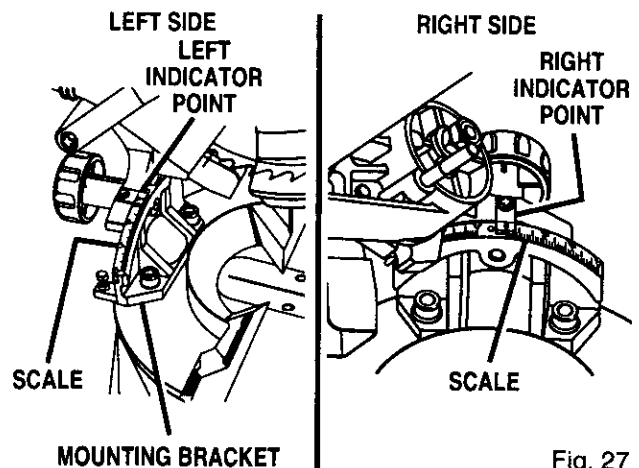

Fig. 27

TO BEVEL CUT WITH YOUR MITER SAW:

- Pull out the lock pin and lift saw arm to its full height.
- Loosen the miter lock handle. Rotate the miter lock handle approximately one-half turn to the left to loosen.
- Press the miter lock plate down with your thumb and hold.
- Rotate the control arm until the pointer aligns with zero on the miter scale.
- Release the miter lock plate.

Note: You can quickly locate zero by releasing the lock plate as you rotate the control arm. The lock plate will seat itself in one of the built-in positive stop notches, located in the miter table frame.

- Tighten the miter lock handle securely.

⚠ WARNING: To avoid serious personal injury, always tighten the miter lock handle securely before making a cut. Failure to do so could result in movement of the control arm or miter table while making a cut.

OPERATION

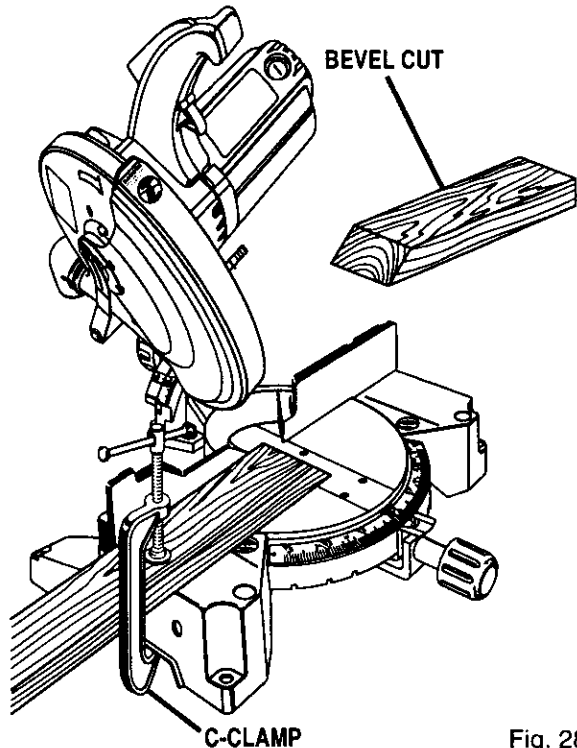

Fig. 28

- Loosen the bevel lock knob and move the saw arm to the left to the desired bevel angle.
- Bevel angles can be set from 0° to 45°.
- For your convenience there is a double scale located on the mounting bracket. See Figure 27. If one side becomes difficult to read as you move the saw arm to the left, simply refer to the other side. Always use the indicator point for the side you choose with the desired angle.
- Once the saw arm has been set at the desired angle, securely tighten the bevel lock knob.
- Place the workpiece flat on the miter table with one edge securely against the fence. If the board is warped, place the convex side against the fence. If the concave edge of a board is placed against the fence, the board could collapse on the blade at the end of the cut, jamming the blade. See Figures 33 and 34.
- When cutting long pieces of lumber or molding, support the opposite end of the stock with a roller stand or with a work surface level with the saw table.
- Align the cutting line on the workpiece with the edge of saw blade.
- Grasp the stock firmly with one hand and secure it against the fence. Use the optional work clamp or a C-clamp to secure the workpiece when possible. See Figure 28.

⚠ WARNING: To avoid serious personal injury, keep your hands outside the no hands zone; at least 3 in. from blade. Never perform any cutting operation freehand (without holding workpiece against the fence). The blade could grab the workpiece if it slips or twists.

- Before turning on the saw, perform a dry run of the cutting operation just to make sure that no problems will occur when the cut is made.
- Grasp the saw handle firmly, press the lock-off tab down, then squeeze the switch trigger. Allow several seconds for the blade to reach maximum speed.
- Slowly lower the blade into and through the workpiece. See Figure 28.
- Release the switch trigger and allow the saw blade to stop rotating before raising the blade out of workpiece. Wait until the electric brake stops blade from turning before removing the workpiece from miter table.

COMPOUND MITER CUT

A compound miter cut is a cut made using a miter angle and a bevel angle at the same time. This type of cut is used to make picture frames, cut molding, make boxes with sloping sides, and for certain roof framing cuts.

To make this type of cut the control arm on the miter table must be rotated to the correct angle and the saw arm must be tilted to the correct bevel angle. Care should always be taken when making compound miter setups due to the interaction of the two angle settings.

Adjustments of miter and bevel settings are interdependent with one another. Each time you adjust the miter setting you change the effect of the bevel setting. Also, each time you adjust the bevel setting you change the effect of the miter setting.

It may take several settings to obtain the desired cut. The first angle setting should be checked after setting the second angle, since adjusting the second angle affects the first.

Once the two correct settings for a particular cut have been obtained, always make a test cut in scrap material before making a finish cut in good material.

OPERATION

TO MAKE A COMPOUND CUT WITH YOUR MITER SAW:

- Pull out the lock pin and lift saw arm to its full height.
- Loosen the miter lock handle. Rotate the miter lock handle approximately one-half turn to the left to loosen.
- Press the miter lock plate down with your thumb and hold.
- Rotate the control arm until the pointer aligns with the desired angle on the miter scale.
- Release the miter lock plate.

Note: You can quickly locate 0°, 22-1/2° left or right, and 45° left or right by releasing the miter lock plate as you rotate the control arm. The miter lock plate will seat itself in one of the positive stop notches, located in miter table frame.

- Tighten the miter lock handle securely.

⚠ WARNING: To avoid serious personal injury, always tighten the miter lock handle securely before making a cut. Failure to do so could result in movement of the control arm or miter table while making a cut.

- Loosen the bevel lock knob and move the saw arm to the left to the desired bevel angle.
- Bevel angles can be set from 0° to 45°.
- For your convenience there is a double scale located on the mounting bracket. *See Figure 27.* If one side becomes difficult to read as you move the saw arm to the left, simply refer to the other side. Align the indicator point for the side you choose with the desired angle.
- Once the saw arm has been set at the desired angle, securely tighten the bevel lock knob.

- Recheck miter angle setting. Make a test cut in scrap material.
- Place the workpiece flat on the miter table with one edge securely against the fence. If the board is warped, place the convex side against the fence. If the concave edge of a board could collapse on the blade at the end of the cut, jamming the blade. *See Figures 33 and 34.*
- When cutting long pieces of lumber or molding, support the opposite end of the stock with a roller stand or with a work surface level with the saw table.
- Align the cutting line on the workpiece with the edge of saw blade.
- Grasp the stock firmly with one hand and secure it against the fence. Use the optional work clamp or a C-clamp to secure the workpiece when possible. *See Figure 29.*

⚠ WARNING: To avoid serious personal injury, always keep your hands outside the no hands zone; at least 3 in. from blade. Never perform any cutting operation freehand (without holding workpiece against the fence). The blade could grab the workpiece if it slips or twists.

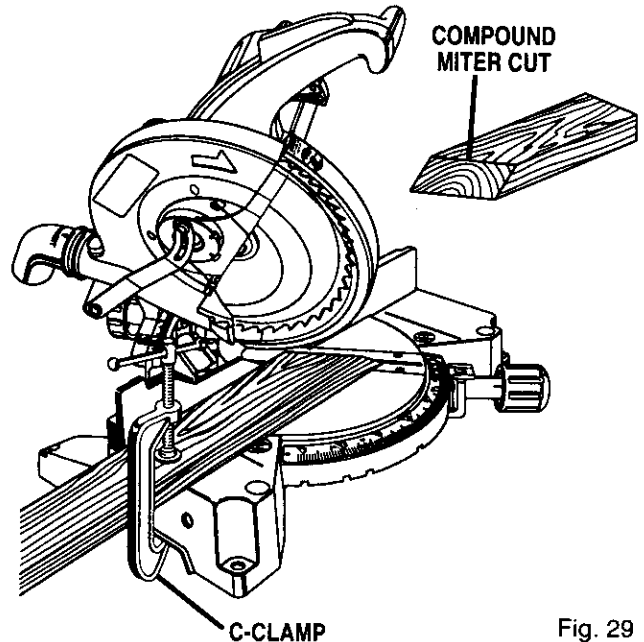

Fig. 29

OPERATION

- Before turning on the saw, perform a dry run of the cutting operation just to make sure that no problems will occur when the cut is made.
- Grasp the saw handle firmly, press the lock-off tab down, then squeeze the switch trigger. Allow several seconds for the blade to reach maximum speed.
- Slowly lower the blade into and through the workpiece. See Figures 29 and 30.
- Release the switch trigger and allow the saw blade to stop rotating before raising the blade out of workpiece. Wait until the electric brake stops blade from turning before removing the workpiece from miter table.

SUPPORT LONG WORKPIECES

See Figure 31.

Long workpieces need extra supports. Supports should be placed along the workpiece so it does not sag. The support should let the workpiece lay flat on the base of the saw and work table during the cutting operation. Use the optional work clamp or a C-clamp to secure the workpiece.

⚠ WARNING: To avoid serious personal injury, always keep your hands outside the no hands zone; at least 3 in. from blade. Never perform any cutting operation freehand (without holding workpiece against the fence). The blade could grab the workpiece if it slips or twists.

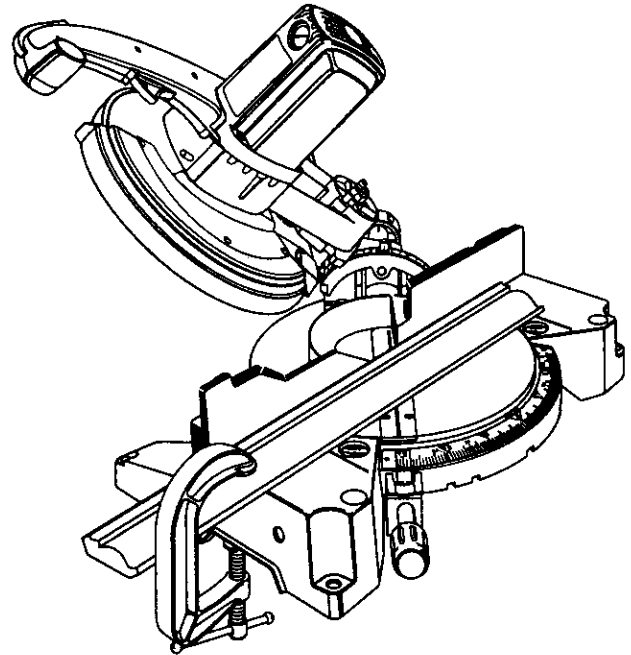

45° X 45° COMPOUND MITER CUT

Fig. 30

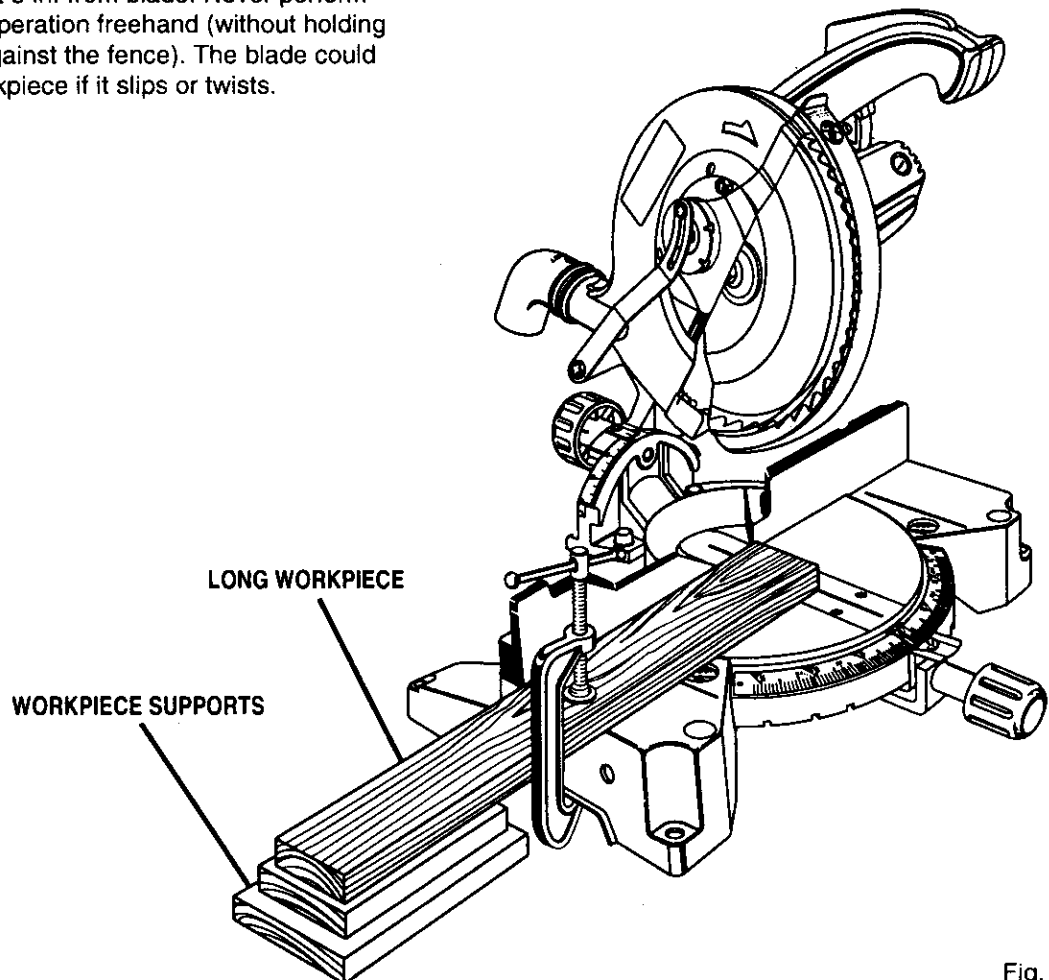

Fig. 31

OPERATION

CUTTING COMPOUND MITERS

To aid in making the correct settings, the compound angle setting chart below has been provided. Since compound cuts are the most difficult to accurately obtain, trial cuts should be made in scrap material, and much thought and planning made, prior to making your required cut.

| PITCH OF SIDE | NUMBER OF SIDES | | | | | | |
|---------------|------------------------|------------------------|------------------------|------------------------|------------------------|------------------------|------------------------|
| | 4 | 5 | 6 | 7 | 8 | 9 | 10 |
| 0° | M- 45.00° B- 0.00° | M- 36.00° B- 0.00° | M- 30.00° B- 0.00° | M- 25.71° B- 0.00° | M- 22.50° B- 0.00° | M- 20.00° B- 0.00° | M- 18.00° B- 0.00° |
| 5° | M- 44.89° B- 3.53° | M- 35.90° B- 2.94° | M- 29.91° B- 2.50° | M- 25.63° B- 2.17° | M- 22.42° B- 1.91° | M- 19.93° B- 1.71° | M- 17.94° B- 1.54° |
| 10° | M- 44.56° B- 7.05° | M- 35.58° B- 5.86° | M- 29.62° B- 4.98° | M- 25.37° B- 4.32° | M- 22.19° B- 3.81° | M- 19.72° B- 3.40° | M- 17.74° B- 3.08° |
| 15° | M- 44.01° B- 10.55° | M- 35.06° B- 8.75° | M- 29.15° B- 7.44° | M- 24.95° B- 6.45° | M- 21.81° B- 5.68° | M- 19.37° B- 5.08° | M- 17.42° B- 4.59° |
| 20° | M- 43.22° B- 14.00° | M- 34.32° B- 11.60° | M- 28.48° B- 9.85° | M- 24.35° B- 8.53° | M- 21.27° B- 7.52° | M- 18.88° B- 6.72° | M- 16.98° B- 6.07° |
| 25° | M- 42.19° B- 17.39° | M- 33.36° B- 14.38° | M- 27.62° B- 12.20° | M- 23.56° B- 10.57° | M- 20.58° B- 9.31° | M- 18.26° B- 8.31° | M- 16.41° B- 7.50° |
| 30° | M- 40.89° B- 20.70° | M- 32.18° B- 17.09° | M- 26.57° B- 14.48° | M- 22.64° B- 12.53° | M- 19.73° B- 11.03° | M- 17.50° B- 9.85° | M- 15.72° B- 8.89° |
| 35° | M- 39.32° B- 23.93° | M- 30.76° B- 19.70° | M- 25.31° B- 16.67° | M- 21.53° B- 14.41° | M- 18.74° B- 12.68° | M- 16.60° B- 11.31° | M- 14.90° B- 10.21° |
| 40° | M- 37.45° B- 27.03° | M- 29.10° B- 22.20° | M- 23.86° B- 18.75° | M- 20.25° B- 16.19° | M- 17.60° B- 14.24° | M- 15.58° B- 12.70° | M- 13.98° B- 11.46° |
| 45° | M- 35.26° B- 30.00° | M- 27.19° B- 24.56° | M- 22.21° B- 20.70° | M- 18.80° B- 17.87° | M- 16.32° B- 15.70° | M- 14.43° B- 14.00° | M- 12.94° B- 12.62° |
| 50° | M- 32.73° B- 32.80° | M- 25.03° B- 26.76° | M- 20.36° B- 22.52° | M- 17.20° B- 19.41° | M- 14.91° B- 17.05° | M- 13.17° B- 15.19° | M- 11.80° B- 13.69° |
| 55° | M- 29.84° B- 35.40° | M- 22.62° B- 28.78° | M- 18.32° B- 24.18° | M- 15.44° B- 20.82° | M- 13.36° B- 18.27° | M- 11.79° B- 16.27° | M- 10.56° B- 14.66° |
| 60° | M- 26.57° B- 37.76° | M- 19.96° B- 30.60° | M- 16.10° B- 25.66° | M- 13.54° B- 22.07° | M- 11.70° B- 19.35° | M- 10.31° B- 17.23° | M- 9.23° B- 15.52° |
| 65° | M- 22.91° B- 39.86° | M- 17.07° B- 32.19° | M- 13.71° B- 26.95° | M- 11.50° B- 23.16° | M- 9.93° B- 20.29° | M- 8.74° B- 18.06° | M- 7.82° B- 16.26° |
| 70° | M- 18.88° B- 41.64° | M- 13.95° B- 33.53° | M- 11.17° B- 28.02° | M- 9.35° B- 24.06° | M- 8.06° B- 21.08° | M- 7.10° B- 18.75° | M- 6.34° B- 16.88° |
| 75° | M- 14.51° B- 43.08° | M- 10.65° B- 34.59° | M- 8.50° B- 28.88° | M- 7.10° B- 24.78° | M- 6.12° B- 21.69° | M- 5.38° B- 19.29° | M- 4.81° B- 17.37° |
| 80° | M- 9.85° B- 44.14° | M- 7.19° B- 35.37° | M- 5.73° B- 29.50° | M- 4.78° B- 25.30° | M- 4.11° B- 22.14° | M- 3.62° B- 19.68° | M- 3.23° B- 17.72° |
| 85° | M- 4.98° B- 44.78° | M- 3.62° B- 35.84° | M- 2.88° B- 29.87° | M- 2.40° B- 25.61° | M- 2.07° B- 22.41° | M- 1.82° B- 19.92° | M- 1.62° B- 17.93° |
| 90° | M- 0.00° B- 45.00° | M- 0.00° B- 36.00° | M- 0.00° B- 30.00° | M- 0.00° B- 25.71° | M- 0.00° B- 22.50° | M- 0.00° B- 20.00° | M- 0.00° B- 18.00° |

Each B (Bevel) and M (Miter) Setting is Given to the Closest 0.005°.

COMPOUND-ANGLE SETTINGS FOR POPULAR STRUCTURES

OPERATION

CUTTING CROWN MOLDING

Your compound miter saw does an excellent job of cutting crown molding. In general, compound miter saws do a better job of cutting crown molding than any other tool made.

In order to fit properly, crown molding must be compound mitered with extreme accuracy.

The two contact surfaces on a piece of crown molding that fit flat against the ceiling and the wall of a room are at angles that, when added together, equal exactly 90° . Most crown molding has a top rear angle (the section that fits flat against the ceiling) of 52° and a bottom rear angle (the section that fits flat against the wall) of 38° .

LAYING MOLDING FLAT ON THE MITER TABLE

See Figure 32.

To use this method for accurately cutting crown molding for a 90° inside or outside corner, lay the molding with its broad back surface flat on the miter table and against the fence.

When setting the bevel and miter angles for compound miters, remember that the settings are interdependent; changing one angle changes the other angle as well.

Keep in mind that the angles for crown moldings are very precise and difficult to set. Since it is very easy for these angles to shift, all settings should first be tested on scrap molding. Also most walls do not have angles of exactly 90° , therefore, you will need to fine tune your settings.

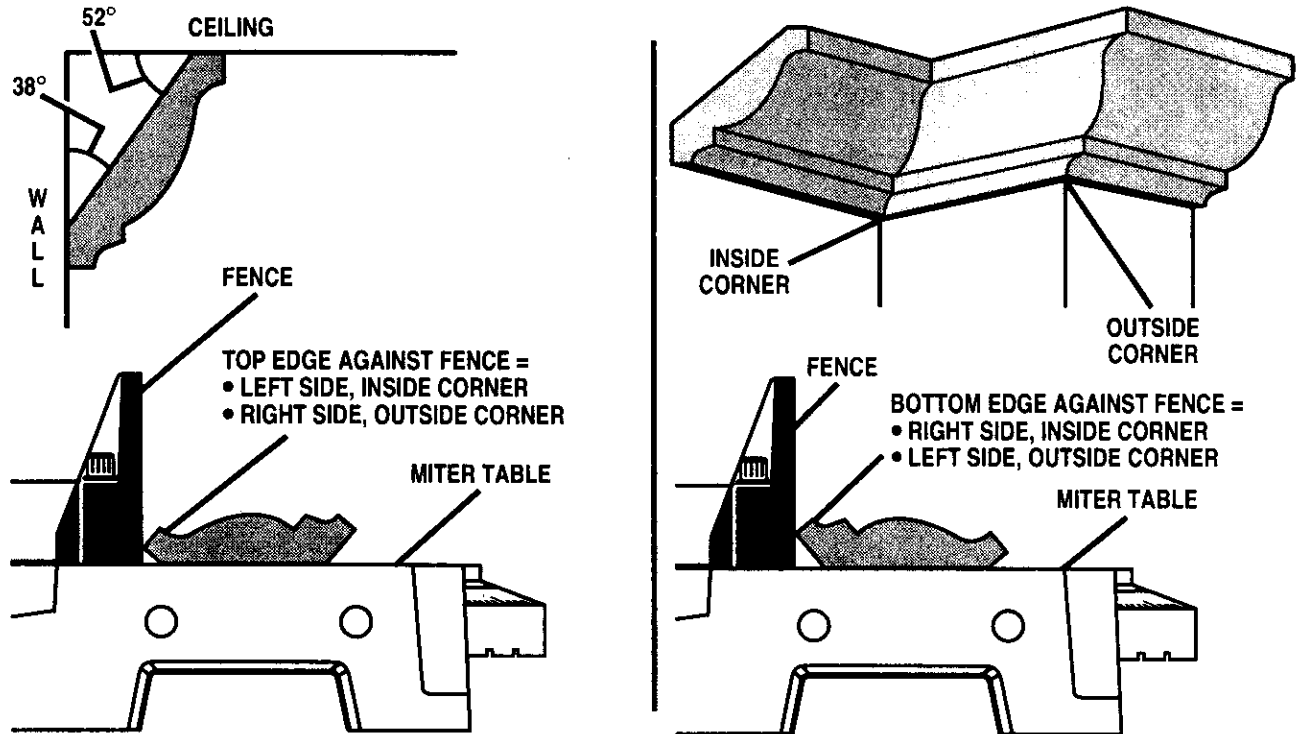

CROWN MOLDING FLAT ON MITER TABLE

Fig. 32

OPERATION

When cutting crown molding by this method the bevel angle should be set at 33.85°. The miter angle should be set at 31.62° either right or left, depending on the desired cut for the application. See the chart below for correct angle settings and correct positioning of crown molding on miter table.

The settings in the chart below can be used for cutting All Standard (U.S.) crown molding with 52° and 38° angles. The crown molding is placed flat on the miter table using the compound features of your miter saw.

| Bevel Angle Setting | Type of Cut |
|---------------------|---|
| 33.85° | Left side, inside corner 1. Top edge of molding against fence 2. Miter table set right 31.62° 3. Save left end of cut |
| 33.85° | Right side, inside corner 1. Bottom edge of molding against fence 2. Miter table set left 31.62° 3. Save left end of cut |
| 33.85° | Left side, outside corner 1. Bottom edge of molding against fence 2. Miter table set left 31.62° 3. Save right end of cut |
| 33.85° | Right side, outside corner 1. Top edge of molding against fence 2. Miter table set right 31.62° 3. Save right end of cut |

CUTTING WARPED MATERIAL

See Figures 33 and 34.

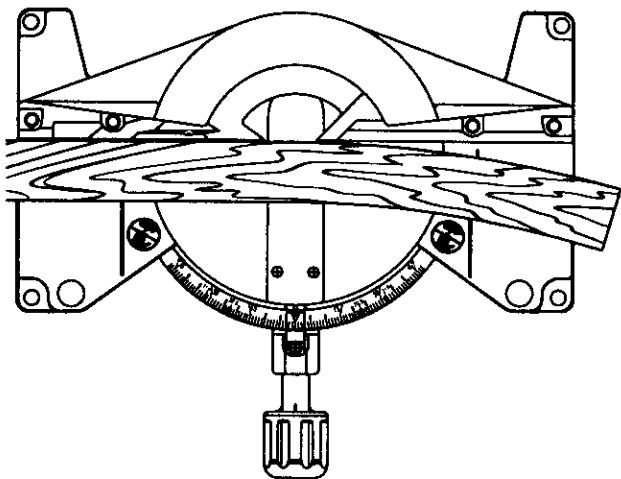

RIGHT

Fig. 33

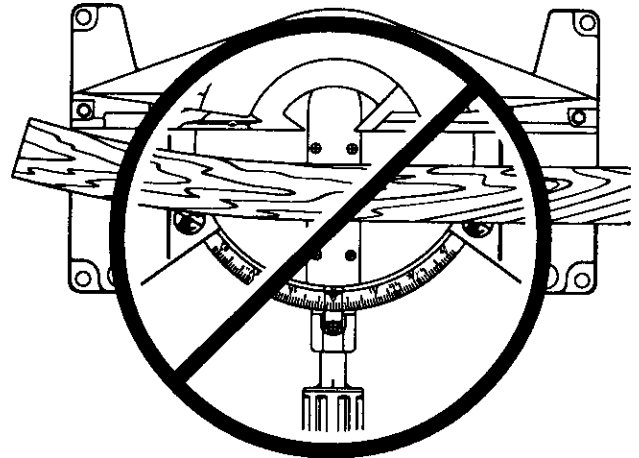

WRONG

Fig. 34

When cutting warped material, always make sure it is positioned on the miter table with the convex side against the fence as shown in figure 33.

If the warped material is positioned the wrong way as shown in figure 34, it will pinch the blade near the completion of the cut.

⚠ WARNING: To avoid a kickback and to avoid serious personal injury, never position the concave edge of bowed or warped material against the fence.

CLAMPING WIDE WORKPIECES

See Figure 35.

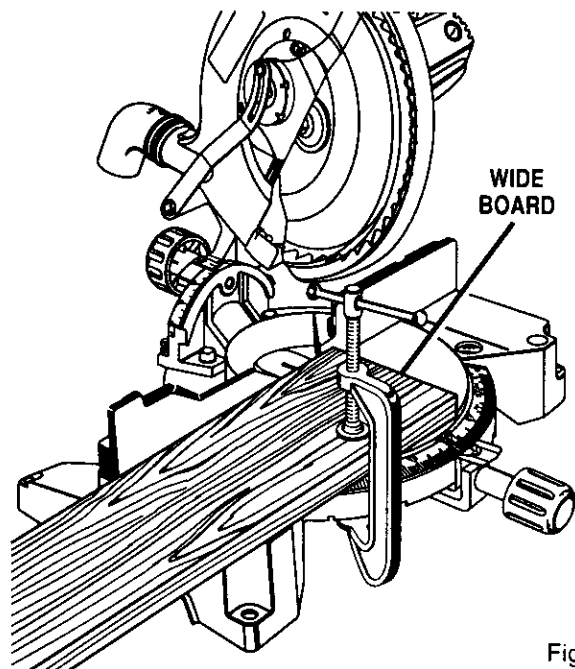

Fig. 35

When cutting wide workpieces such as a 2 in. x 6 in., boards should be clamped with a C-clamp as shown in figure 35.

MAINTENANCE

⚠ WARNING: When servicing, use only identical Craftsman replacement parts. Use of any other part may create a hazard or cause product damage.

GENERAL

Avoid using solvents when cleaning plastic parts. Most plastics are susceptible to damage from various types of commercial solvents and may be damaged by their use. Use clean cloths to remove dirt, carbon dust, etc.

⚠ WARNING: Do not at any time let brake fluids, gasoline, petroleum-based products, penetrating oils, etc. come in contact with plastic parts. They contain chemicals that can damage, weaken or destroy plastic.

It has been found that electric tools are subject to accelerated wear and possible premature failure when they are used on fiberglass boats, sports cars, wallboard, spackling compounds, or plaster. The chips and grindings from these materials are highly abrasive to electric tool parts such as bearings, brushes, commutators, etc. Consequently, it is not recommended that this tool be used for extended work on any fiberglass material, wallboard, spackling compounds, or plaster. During any use on these materials it is extremely important that the tool is cleaned frequently by blowing with an air jet.

LUBRICATION

All of the bearings in this tool are lubricated with a sufficient amount of high grade lubricant for the life of the unit under normal operating conditions. Therefore, no further lubrication is required.

EXTENSION CORDS

The use of any extension cord will cause some loss of power. To keep the loss to a minimum and to prevent tool overheating, use an extension cord that is heavy enough to carry the current the tool will draw.

A wire gage size (A.W.G.) of at least **14** is recommended for an extension cord 25 feet or less in length. When working outdoors, use an extension cord that is suitable for outdoor use. The cord's jacket will be marked WA.

⚠ CAUTION: Keep extension cords away from the cutting area and position the cord so that it will not get caught on lumber, tools, etc., during cutting operation.

⚠ WARNING: Check extension cords before each use. If damaged, replace immediately. Never use tool with a damaged cord since touching the damaged area could cause electrical shock resulting in serious injury.

⚠ WARNING: Always wear safety goggles or safety glasses with side shields during power tool operation or when blowing dust. If operation is dusty, also wear a dust mask.

MAINTENANCE

⚠ WARNING: To ensure safety and reliability, all repairs — with the exception of the externally accessible brushes — should be performed by a qualified service technician at a Sears store to avoid risk of personal injury.

BRUSH REPLACEMENT

See Figure 36.

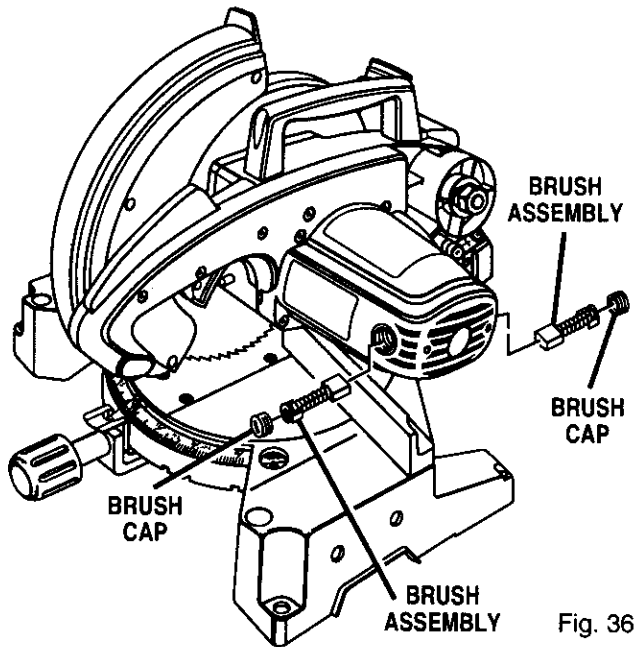

Fig. 36

Your saw has externally accessible brush assemblies that should be periodically checked for wear.

Proceed as follows when replacement is required:

- Unplug your saw.

⚠ WARNING: Failure to unplug your saw could result in accidental starting causing serious injury.

- Remove brush cap with a screwdriver. Brush assembly is spring loaded and will pop out when you remove brush cap.
- Remove brush assembly.
- Check for wear. Replace both brushes when either has less than 1/4 in. length of carbon remaining. **Do not** replace one side without replacing the other.
- Reassemble using new brush assemblies. Make sure curvature of brush matches curvature of motor and that brush moves freely in brush tube.
- Make sure brush cap is oriented correctly (straight) and replace.
- Tighten brush cap securely. **Do not** overtighten.

CRAFTSMAN COMPOUND MITER SAW - MODEL NUMBER 315.243000

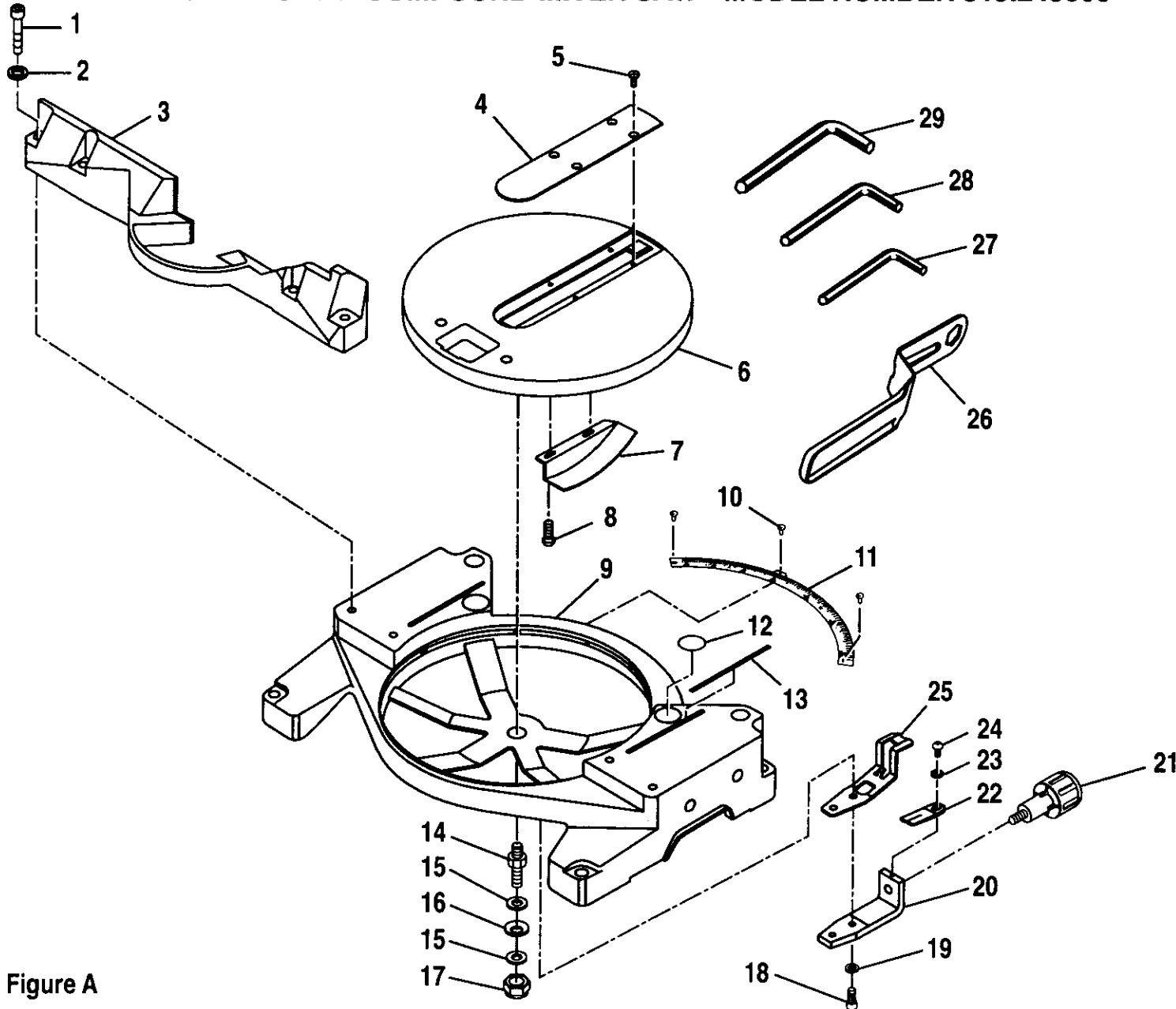

Figure A

30

CRAFTSMAN COMPOUND MITER SAW - MODEL NUMBER 315.243000

The model number will be found on a plate attached to the motor housing. Always mention the model number in all correspondence regarding your **CRAFTSMAN COMPOUND MITER SAW** or when ordering repair parts.

PARTS LIST FOR FIGURE A

| KEY NO. | PART NUMBER | DESCRIPTION | QUAN. | KEY NO. | PART NUMBER | DESCRIPTION | QUAN. |
|---------|-------------|---|-------|---------|-------------|------------------------------|-------|
| 1 | 710308-045 | Bolt (M8 x 45 Soc. Hd.) | 4 | 16 | 976511-001 | Spring Washer | 1 |
| 2 | 360308-142 | Lock Washer (M8) | 4 | 17 | 976578-001 | Nylon Lock Nut | 1 |
| 3 | 977443-001 | Fence | 1 | 18 | 700306-025 | Screw (Socket Hd. Cap) | 2 |
| 4 | 976516-001 | Zero Clearance Throat Plate | 1 | 19 | 360306-121 | Lock Washer | 2 |
| 5 | 160030-400 | Screw | 4 | 20 | 976501-001 | Control Arm | 1 |
| 6 | 976514-001 | Miter Table | 1 | 21 | 976505-001 | Miter Lock Handle | 1 |
| 7 | 976598-001 | Cover Plate | 1 | 22 | 976506-001 | Pointer | 1 |
| 8 | 976601-001 | Screw (Pan Hd.) | 2 | 23 | 976526-001 | Flat Washer (M4) | 1 |
| 9 | 976610-001 | Miter Table Frame (Includes Key Nos. 10, 11, 12, & 13) | 1 | 24 | 976527-001 | Screw (M4 x 10) | 1 |
| 10 | 976531-001 | Rivet | 3 | 25 | 976509-001 | Miter Lock Plate | 1 |
| 11 | 976515-001 | Miter Scale | 1 | 26 | 976568-001 | Blade Wrench | 1 |
| 12 | 977434-001 | Hand Warning Label | 2 | 27 | 976570-001 | 5 mm Hex Key | 1 |
| 13 | 977435-001 | Line Label | 2 | 28 | 976605-001 | 6 mm Hex Key | 1 |
| 14 | 976513-001 | Table Spindle | 1 | 29 | 976569-001 | 8 mm Hex Key | 1 |
| 15 | 976512-001 | Washer | 2 | | | | |

*** AVAILABLE AT YOUR NEAREST SEARS CATALOG ORDER OR RETAIL STORE

CRAFTSMAN COMPOUND MITER SAW - MODEL NUMBER 315.243000

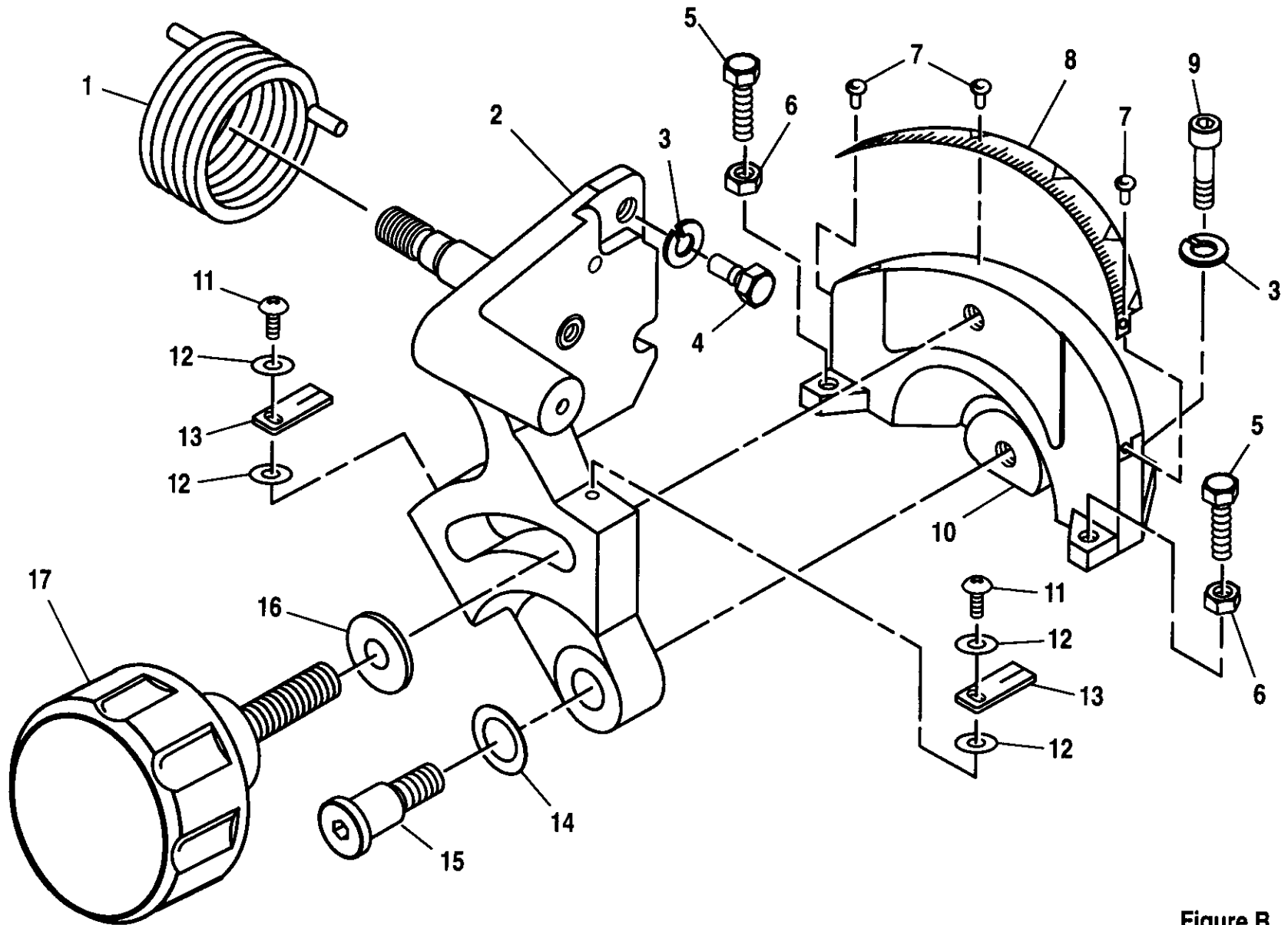

Figure B

CRAFTSMAN COMPOUND MITER SAW - MODEL NUMBER 315.243000

The model number will be found on a plate attached to the motor housing. Always mention the model number in all correspondence regarding your **COMPOUND MITER SAW** or when ordering repair parts.

PARTS LIST FOR FIGURE B

| KEY NO. | PART NUMBER | DESCRIPTION | QUAN. | KEY NO. | PART NUMBER | DESCRIPTION | QUAN. |
|---------|-------------|-------------------------------|-------|---------|-------------|---|-------|
| 1 | 976528-001 | Torsion Spring | 1 | 10 | 976609-001 | Bevel Pivot Bracket Assembly (Includes Key Nos. 7 & 8) | 1 |
| 2 | 977441-001 | Support Bracket | 1 | 11 | 976527-001 | Screw | 2 |
| 3 | 976530-001 | Lock Washer | 3 | 12 | 976526-001 | Washer | 4 |
| 4 | 976529-001 | Bolt | 1 | 13 | 976525-001 | Bevel Index Pointer | 2 |
| 5 | 976518-001 | Hex Bolt | 2 | 14 | 976520-001 | Washer | 1 |
| 6 | 976519-001 | Hex Nut | 2 | 15 | 976521-001 | Pivot Shaft | 1 |
| 7 | 976531-001 | Rivet | 3 | 16 | 976512-001 | Washer (M10) | 1 |
| 8 | 976535-001 | Bevel Scale | 1 | 17 | 976522-001 | Bevel Lock Knob | 1 |
| 9 | 700310-025 | Bolt (M10 x 25 Hex Hd.) | 2 | | | | |

CRAFTSMAN COMPOUND MITER SAW - MODEL NUMBER 315.243000

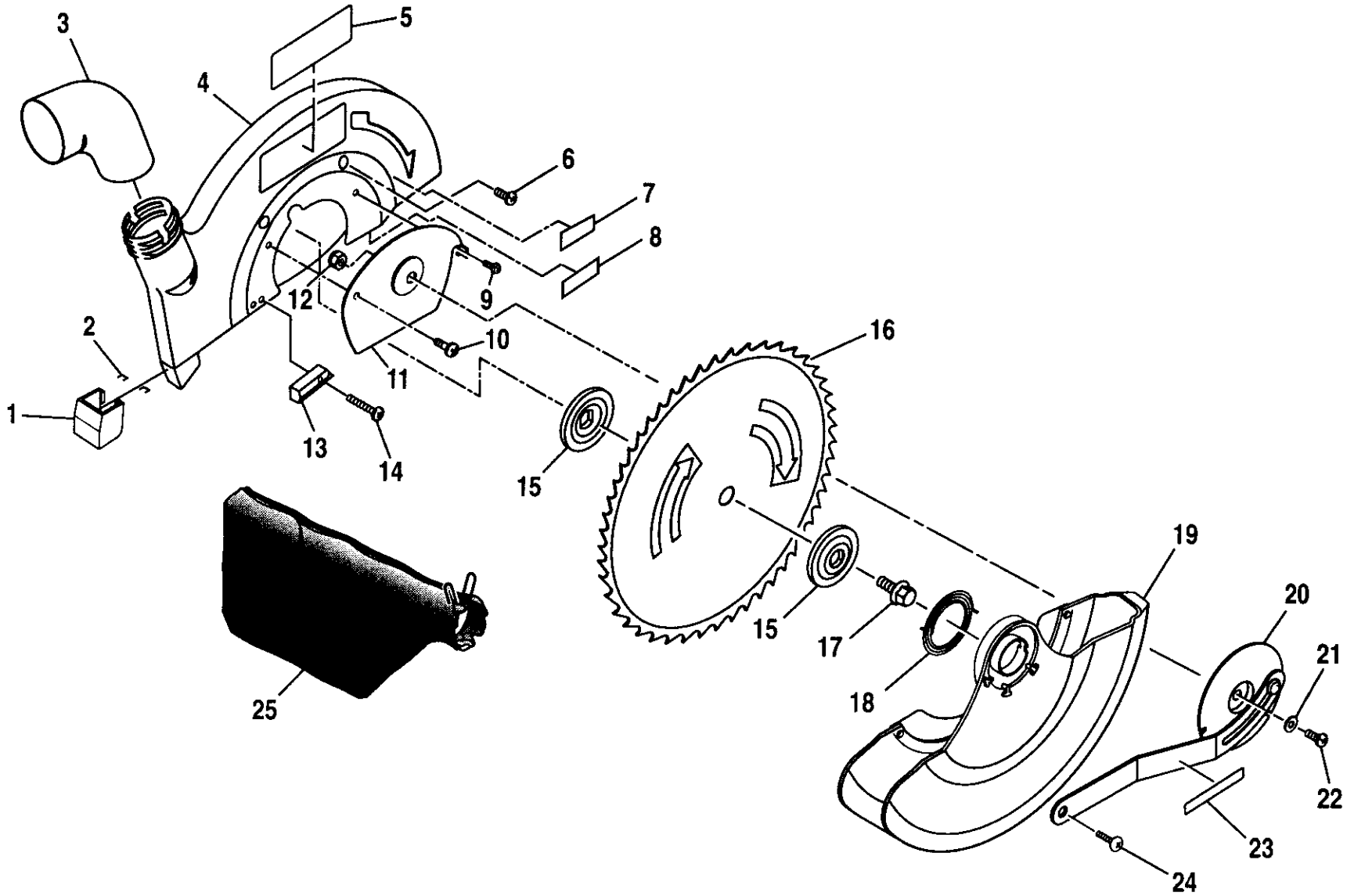

34

Figure C

CRAFTSMAN COMPOUND MITER SAW - MODEL NUMBER 315.243000

The model number will be found on a plate attached to the motor housing. Always mention the model number in all correspondence regarding your **COMPOUND MITER SAW** or when ordering repair parts.

PARTS LIST FOR FIGURE C

| KEY NO. | PART NUMBER | DESCRIPTION | QUAN. | KEY NO. | PART NUMBER | DESCRIPTION | QUAN. |
|---------|-------------|-------------------------------|-------|---------|-----------------|---|-------|
| 1 | 976539-001 | Dust Shield | 1 | 14 | 130030-401 | Screw (M4 x 15) | 1 |
| 2 | 976596-001 | U-Clip | 2 | 15 | 976547-001 | Blade Washer | 2 |
| 3 | 976567-001 | Dust Guide | 1 | 16 | *** | Saw Blade | 1 |
| 4 | 976543-001 | Upper Blade Guard | 1 | 17 | 976548-001 | Blade Bolt (M8 x 20) | 1 |
| 5 | 979687-001 | Logo Plate | 1 | 18 | 976554-001 | Return Spring | 1 |
| 6 | 976599-001 | Screw (M5 x 12) | 4 | 19 | 976607-001 | Lower Blade Guard Assembly | 1 |
| 7 | 976733-001 | Lower Blade Guard Label | 1 | 20 | 976608-001 | Blade Guard Bracket Assembly (Includes Key No. 23) | 1 |
| 8 | 976540-001 | Caution Label | 1 | 21 | 976507-001 | Washer (M5) | 1 |
| 9 | 976604-001 | Phillips Screw | 1 | 22 | 130030-501 | Screw (M5 x 10) | 1 |
| 10 | 976600-001 | Fixed Screw | 1 | 23 | 976740-001 | Label | 1 |
| 11 | 976552-001 | Blade Bolt Cover | 1 | 24 | 976564-001 | Screw | 1 |
| 12 | 976549-001 | Lock Nut | 1 | 25 | Item No. 923466 | Dust Bag | 1 |
| 13 | 976541-001 | Stopper | 1 | | | | |

*** COMPLETE ASSORTMENT AVAILABLE AT YOUR NEAREST SEARS CATALOG ORDER OR RETAIL STORE

CRAFTSMAN COMPOUND MITER SAW - MODEL NUMBER 315.243000

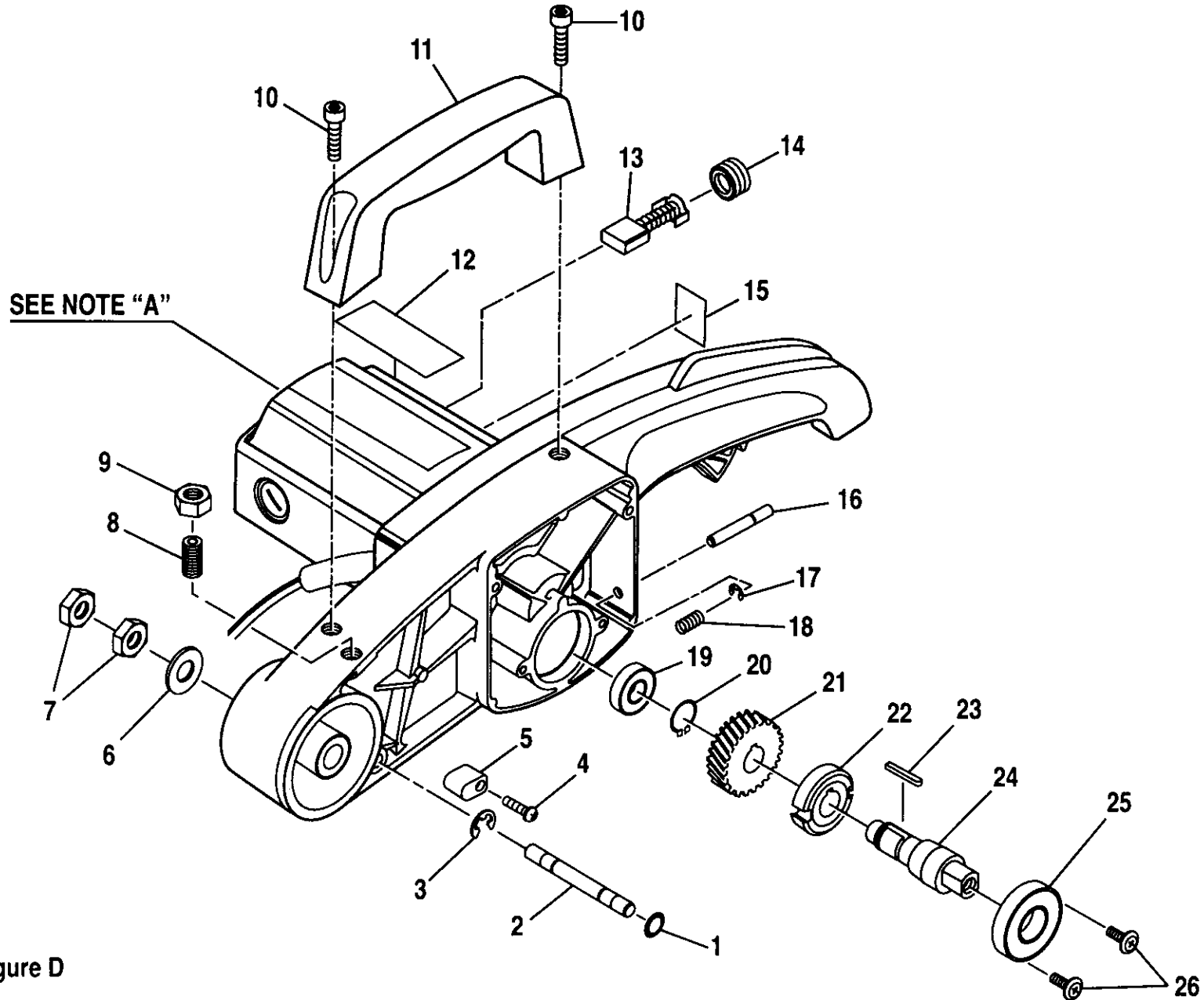

Figure D

CRAFTSMAN COMPOUND MITER SAW - MODEL NUMBER 315.243000

The model number will be found on a plate attached to the motor housing. Always mention the model number in all correspondence regarding your **CRAFTSMAN COMPOUND MITER SAW** or when ordering repair parts.

PARTS LIST FOR FIGURE D

| KEY NO. | PART NUMBER | DESCRIPTION | QUAN. | KEY NO. | PART NUMBER | DESCRIPTION | QUAN. |
|---------|-------------|--|-------|---------|-------------|-------------------------------|-------|
| 1 | 976641-001 | "O" Ring | 1 | 15 | 981494-001 | Data Plate | 1 |
| 2 | 976576-001 | Lock Pin | 1 | 16 | 976650-001 | Spindle Lock Pin | 1 |
| 3 | 976643-001 | E-Ring | 1 | 17 | 976651-001 | E-Ring | 1 |
| 4 | 976644-001 | Screw (M4 x 16) | 1 | 18 | 976649-001 | Compression Spring | 1 |
| 5 | 976645-001 | Rubber Bumper | 1 | 19 | 976647-001 | Ball Bearing (6000zz) | 1 |
| 6 | 976536-001 | Flat Washer (M12) | 1 | 20 | 976648-001 | External Retaining Ring | 1 |
| 7 | 976537-001 | Hex Nut (M12) | 2 | 21 | 588028-108 | Gear | 1 |
| 8 | 180031-002 | Depth Stop Adjustment Screw (M10 x 20) | 1 | 22 | 976653-001 | Lock Ring | 1 |
| 9 | 300030-100 | Hex Nut (M10) | 1 | 23 | 976654-001 | Square Key (4 x 4 x 28) | 1 |
| 10 | 976664-001 | Screw | 2 | 24 | 588030-008 | Gear Shaft | 1 |
| 11 | 976663-001 | Carrying Handle | 1 | 25 | 976658-001 | Ball Bearing (6004zz) | 1 |
| 12 | 976691-001 | Warning Label | 1 | 26 | 588031-004 | Screw (Special) | 2 |
| 13 | 976683-001 | Brush Assembly | 2 | | 972000-710 | Owner's Manual | |
| 14 | 976682-001 | Brush Cap | 2 | | | | |

NOTE: "A"—THE ASSEMBLY SHOWN REPRESENTS AN IMPORTANT PART OF THE DOUBLE INSULATED SYSTEM. TO AVOID THE POSSIBILITY OF ALTERATION OR DAMAGE TO THE SYSTEM, SERVICE SHOULD BE PERFORMED BY YOUR NEAREST SEARS REPAIR CENTER. CONTACT YOUR NEAREST SEARS CATALOG ORDER OR RETAIL STORE FOR SERVICE CENTER INFORMATION.

For in-home major brand repair service:

Call 24 hours a day, 7 days a week

1-800-4-MY-HomeSM (1-800-469-4663)

Para pedir servicio de reparación a domicilio – 1-800-676-5811

In Canada for all your service and parts needs call – **1-800-665-4455**
Au Canada pour tout le service ou les pièces

For the repair or replacement parts you need:

Call 7 am – 7 pm, 7 days a week

1-800-366-PART (1-800-366-7278)

Para ordenar piezas con entrega a domicilio – 1-800-659-7084

For the location of a Sears Parts and Repair Center in your area:

Call 24 hours a day, 7 days a week

1-800-488-1222

**For information on purchasing a Sears Maintenance Agreement
or to inquire about an existing Agreement:**

Call 9 am – 5 pm, Monday – Saturday

1-800-827-6655



The Service Side of SearsSM