

TM

AlfrescoTM

Open Air Culinary Systems

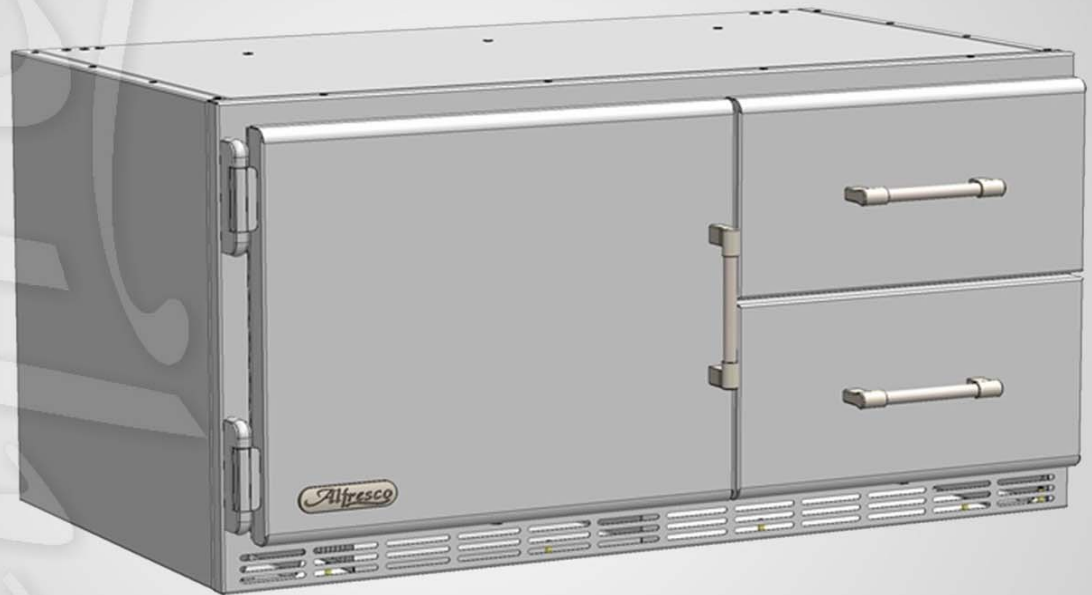

ARXE-42 *Care and Use Manual*

**PLEASE READ THIS MANUAL BEFORE USING YOUR APPLIANCE.
KEEP THIS MANUAL IN A SAFE PLACE FOR FUTURE REFERENCE.**

ASSEMBLER / INSTALLER

Leave these instructions with the customer

CONSUMER/USER

Read these instructions and keep them in a safe place for future reference

NOTE TO CUSTOMER:

This appliance was carefully packed and thoroughly inspected before leaving our factory. Responsibility for its safe delivery was assumed by the carrier upon acceptance of the shipment. As directed on the packing carton, claims for loss or damage sustained in transit must be made to the carrier as follows:

A) Exterior Damage: Make a thorough damage notation on your delivery receipt and have driver acknowledge by signature and date. Send a written request asking for an inspection report from the carrier. Include the name of the carrier representative and the date the inspection was requested. Retain the inspection report and receipt for filing of a claim.

B) Concealed Damage: This must be reported to carrier within fifteen days of receipt. Obtain inspection report from the carrier. Retain inspection report for filing of a claim. **DO NOT RETURN DAMAGED MERCHANDISE TO MANUFACTURER OR DEALER - FILE CLAIM WITH THE CARRIER.**

WARNING:

DO NOT SPLASH OR SPRAY WATER FROM A HOSE ONTO THE REFRIGERATOR. DOING SO MAY CAUSE AN ELECTRICAL SHOCK, INJURY OR DEATH.

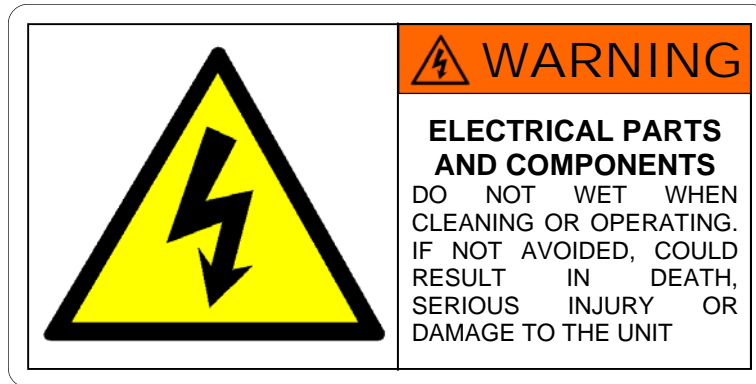

WARNING:

CONTENTS UNDER PRESSURE.

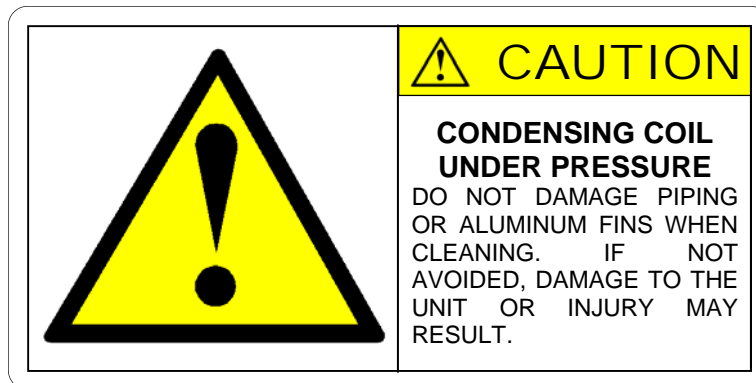

WARNING:

FOR OUTDOOR USE ONLY. THIS APPLIANCE IS NOT INTENDED TO BE INSTALLED IN OR ON RECREATIONAL VEHICLES AND/OR BOATS.

WARNING:

IMPORTANT ELECTRICAL INSTRUCTIONS: THIS REFRIGERATOR IS EQUIPPED WITH A THREE PRONGED (GROUNDING) PLUG FOR YOUR PROTECTION AGAINST SHOCK HAZARD AND SHOULD BE PLUGGED DIRECTLY INTO A PROPERLY GROUNDED THREE-PRONGED RECEPTACLE. DO NOT CUT OR REMOVE THE GROUNDING PRONG FROM THIS PLUG. KEEP CORD AWAY FROM HEATED SURFACES. DO NOT USE AN EXTENSION CORD.

ARXE-42 CONTROL SETTINGS AND TEMPERATURE ADJUSTMENT:

OPERATION:

This unit features a digital electronic control with automatic defrost cycles to prevent the coil from freezing. It operates by lowering the cabinet temperature to your desired setting whilst regularly providing defrost cycles to the unit during operation.

CONTROLS AND LOCATION:

IMPORTANT NOTE:

This refrigerator is programmed with a time delay to protect the compressor. When the unit is powered on, the compressor will not run for approximately ten minutes, this is normal. The refrigeration cycle will then start but it may be a further five to ten minutes before cold air will be perceived inside the unit.

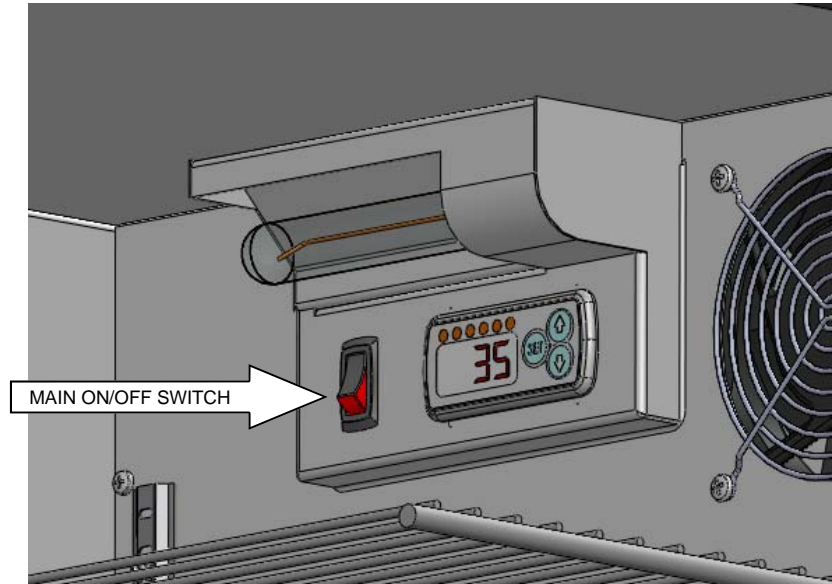

Switch the unit ON using the main ON/OFF power switch, located inside the cabinet, below the light. Immediately after the unit is switched on, the cabinet light and inside evaporator fans will start operating. Check the temperature setting which has been set at the factory to 35°F.

ALFRESCO™ recommends starting the unit at 35°F for optimal operation, only adjusting up or down to your preference once the units' cabinet temperature has stabilized after 24 hours of operation.

To adjust the temperature set point, press and release the "SET" button, whereupon the display will start flashing. Using the up or down arrow, adjust to the desired temperature, then press and release the "SET" button to complete the adjustment.

ADJUSTMENT ITEMS TO REMEMBER:

- **FOR NORMAL OPERATION SET THE UNIT TO 35°F.**
- **DO NOT CHANGE THE TEMPERATURE SETTING WITHOUT ALLOWING TIME FOR THE PREVIOUS SETTING TO TAKE EFFECT; APPROXIMATELY 24 HOURS.**
- **THE COMPRESSOR WILL START AND STOP OFTEN; THIS IS NORMAL OPERATION.**
- **KEEP YOUR REFRIGERATOR LEVELED.**

USE TIPS & ENERGY SAVING IDEAS:

CLEANING:

Exercise caution when sweeping, vacuuming or mopping near the front of the unit.

For normal cleaning, mix 2 tablespoons of baking soda with 1 quart of warm water or use a mild soap. Do not use harsh cleaners or abrasives. Do not splash or spray water onto or under the refrigerator.

TIPS FOR ENERGY SAVING:

Your *ALFRESCO™* refrigerator is designed with the latest technology, to be highly energy efficient. However, following a few simple tips can help save even more energy.

- Limit how often the door is opened.
- Close the door as soon as possible after opening.
- Don't put hot foods into the unit.
- During prolonged periods of non-use, set the temperature to a higher setting or switch the unit off.
- Keep door and drawer gaskets clean to ensure a proper seal.

CARE AND MAINTENANCE OF YOUR REFRIGERATOR:

Stainless Steel is widely used for kitchen equipment because of its strength, its ability to resist corrosion and its ease of cleaning. In fact, stainless steel ranks alongside glass and new china in terms of "ease of cleaning" and in percentage removal of bacteria during washing. As a result of these virtues, the metal is often taken for granted and it is assumed that no problems will arise during its usage. However, some care is required to ensure that the stainless steel can live up to this reputation.

DAY TO DAY CARE

To maintain the original appearance of your *ALFRESCO* Refrigerator, a regular cleaning routine should be carried out using the following guidelines:

After use, wipe the unit with a soft, damp, soapy cloth and rinse with clean water, preferably warm/hot water. This should remove most substances encountered during use.

For more tenacious deposits, including oil, grease and water-borne deposits, use a multipurpose cream cleanser applied with a soft damp cloth. Rinse with clean water.

Harsh abrasives and scouring materials should not be used for cleaning stainless steel as they will leave scratch marks in the surface and damage the appearance. Likewise do not use wire brushes, scrapers or contaminated scouring pads.

If the preceding guidelines are adhered to, your *ALFRESCO* Stainless Steel Refrigerator should offer excellent life and live up to its reputation of being "stainless".

Neglect of this practice, however, can lead to deterioration of the surface and, in some extreme cases, corrosion of the steel itself. The two most common types of corrosion that may be encountered, particularly on stainless steel, are rust marks and pitting of the surface.

RUST BROWN MARKS

When this type of staining occurs it is unlikely that rusting of the stainless steel itself caused the marks. Similar marks can be found with both porcelain and plastic sinks. The rust marks are more likely the result of small particles of "ordinary-steel" which have become attached to the surface and subsequently rusted in the damp environment. The most common source of such particles is from "wire wool" scouring pads, but may also occur from carbon steel utensils and old cast iron water supply pipes.

These brown marks are only superficial stains, which will not harm the unit; they should be removable using a soft damp cloth and multi-purpose cream cleanser. Occasionally, it may be necessary to resort to a proprietary stainless steel cleanser, to return the surface of the unit to its original condition.

PITTING

Another form of corrosion, which occasionally occurs in stainless steel, is pitting of the surface. The reason for this corrosive attack can usually be attributed to certain household products, for example:

BLEACHES

Most common domestic bleaches & sterilizing solutions contain chlorine in the form of sodium hypochlorite. If used in concentrated form, bleaches can attack the stainless steel, causing pitting of the surface. They should always be used to the strengths prescribed by the manufacturer and should be thoroughly rinsed off with clean water immediately after use.

FOODSTUFFS

In general, stainless steel is fully resistant to all foodstuffs in common use. Only in isolated cases, such as when concentrated salt and vinegar mixtures are allowed to remain in contact with the steel for a long period, can any surface marking result.

REPLACING THE INTERIOR LIGHT

Your *ALFRESCO* refrigerator is equipped with an interior light, it is a standard 40 Watt / 120 volts AC refrigerator bulb (also known as a T6.5 intermediate base appliance bulb). To replace, unplug the unit, remove the burned-out bulb located just above the main on/off switch, and install the new one. Plug the unit back into its electrical outlet to restore normal operation.

LIGHT BULB LOCATION:

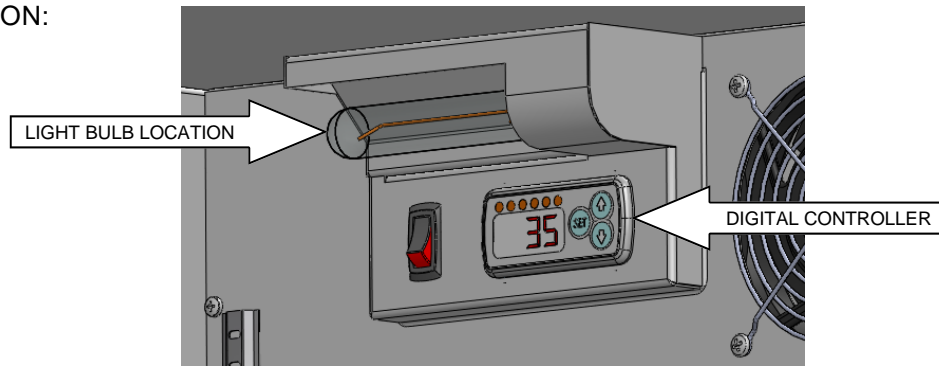

TROUBLESHOOTING

BEFORE CALLING FOR SERVICE

If the unit does not function properly use the following checklist before contacting your dealer for service. You may save the cost of a service call and the inconvenience of being without your refrigerator.

REFRIGERATOR NOT COOLING ENOUGH

Lower the temperature of the cabinet by adjusting the digital thermostat to a lower setting.

NOISY OPERATION

This is usually caused by the unit not being level. Reposition the refrigerator to see if the noise can be eliminated.

MOISTURE ON OR IN UNIT

Warm moist air will condense on cold surfaces. Condensation inside the unit can be caused by too frequent or prolonged opening of the doors. Moisture can also be caused by the thermostat being set too cold. Check the temperature of the unit. Try adjusting to a slightly higher temperature to see if the problem can be eliminated. Minimize door openings and verify that the door gasket is sealing properly around the perimeter.

APPLIANCE RUNS TOO LONG

Running time will change with outside temperature, number of times and length-of-time the doors are open, etc. This is normal in hot or humid weather and is not detrimental to the operation of the unit

LOCATING AND INSTALLING YOUR REFRIGERATOR

NEVER SPLASH OR SPRAY WATER FROM A HOSE DIRECTLY ON THE REFRIGERATOR. DO NOT LOCATE THE UNIT WHERE IT WILL BE SUBJECT TO DIRECT SPRINKLER SPRAY. EXCESSIVE WATER CONTACT MAY RESULT IN ELECTRICAL SHOCK, SERIOUS INJURY OR DEATH.

SELECT LOCATION

The proper location will ensure peak performance of your refrigerator. Choose a location where the unit will be out of direct sunlight and away from heat sources. Your *ALFRESCO* refrigerator is designed to be operated in a properly ventilated area with an ambient temperature of not less than 30°F, nor more than 120°F.

Your *ALFRESCO* refrigerator requires ventilation from the bottom front of the unit. For a cart-mounted (Optional wheel kit) model, keep the area directly in front and behind the unit clear of obstructions. For a built-in unit, make sure the back and bottom of the unit have at least 2 inches of clearance to the cabinet, and that the unit can be easily removed from the cabinet for servicing.

ELECTRICAL SERVICE

All ETL listed refrigerators are equipped with a three pronged plug. Use only the electrical cord supplied with the unit, which must be plugged directly into a properly grounded 3-pronged outlet, preferably a GFCI circuit, in accordance with the National Electrical Code and applicable local codes and ordinances. The third prong (grounding prong) **SHOULD NOT**, under any circumstances, be cut or removed. Do not use an extension cord with this unit.

WIRING DIAGRAM

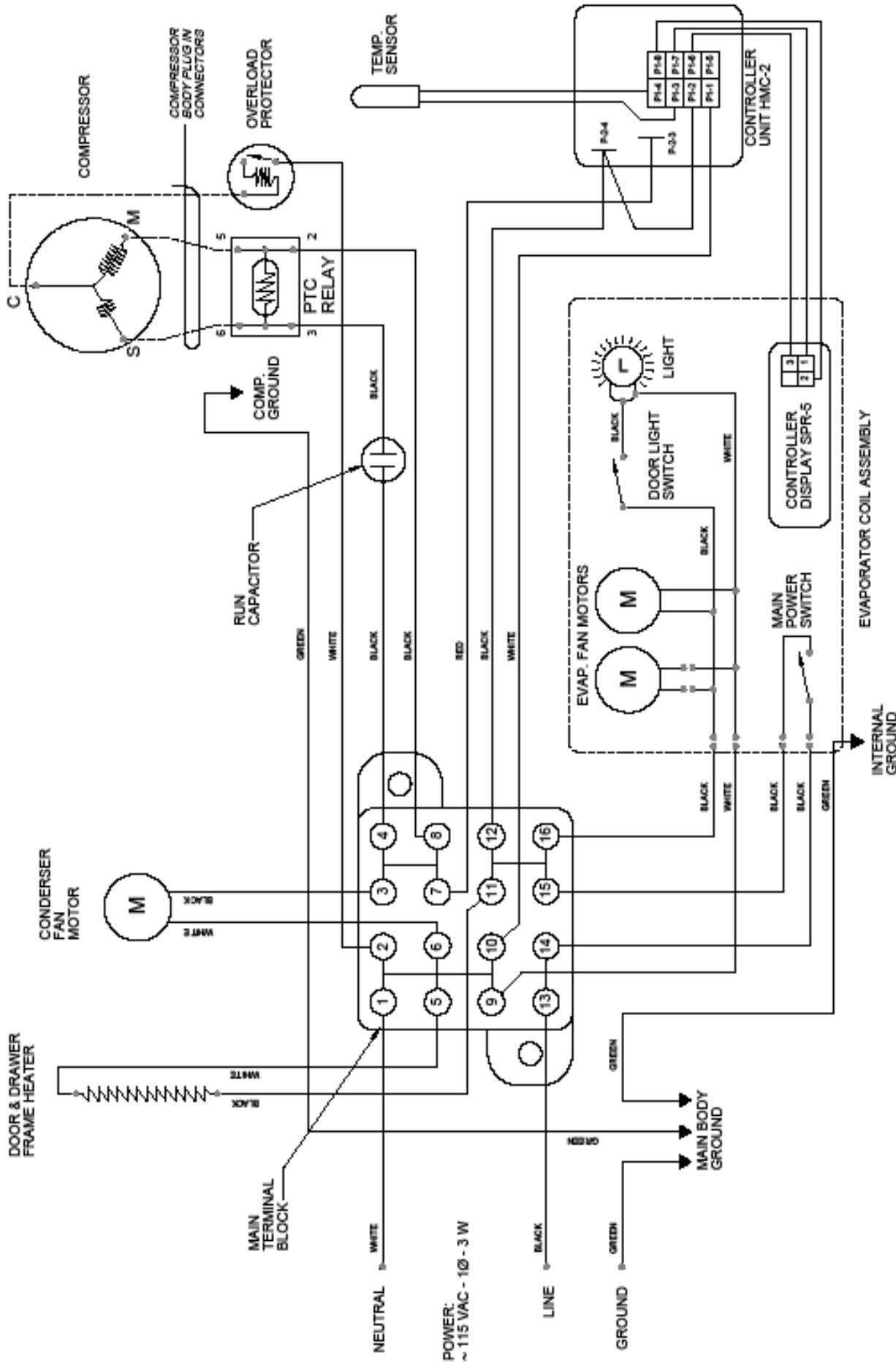

NOTE: CASE MUST BE GROUNDED

<p>ALTESCO SOLUTIONS 2500 EAST SOUTHWEST AVENUE COMMERCE, CA 90040</p>	<p>THE INFORMATION CONTAINED IN THIS DRAWING IS THE PROPERTY OF ALTESCO. IT IS TO BE USED ONLY FOR THE PROJECT AND EQUIPMENT SPECIFICALLY IDENTIFIED HEREIN. ANY REUSE OR MODIFICATION OF THIS INFORMATION WITHOUT WRITTEN PERMISSION FROM ALTESCO IS PROHIBITED.</p>	<p>DRAWN BY: ADRIAN CRISCI</p>	<p>CREATED: 11/15/2006 3:39:17 PM</p>	<p>DRAWING NO.: W900-0044</p>
	<p>CUSTOMER: SES</p>	<p>PROJECT TITLE: ARFG-42</p>	<p>DRAWING TITLE: ARFG-42 UNIT WITH RENAU CONTROL HMC-2</p>	<p>PAGE SIZE: LETTER</p>

Alfresco[™] **Gourmet Limited Warranty**

This warranty covers the following: ALFRESCO GOURMET REFRIGERATORS (All Models)

DURATION OF WARRANTY

Alfresco Gourmet Grills, (a division of SES, Inc) warrants all refrigerator components to the original purchaser to be free of factory defects in material and workmanship for a period of one (1) year from the original date of purchase. This limited warranty covers the structural integrity of the exterior and interior body parts, compressor and refrigeration components. Should structural deterioration occur to the degree of non-performance, a replacement will be furnished FOB Commerce, California. This warranty does not apply if the unit was subject to other than normal household use.

Alfresco Gourmet Grills WILL Cover:

All repair labor and replacement parts for one year, for parts found to be defective due to materials or workmanship. Authorized Factory Agent must provide Service during normal working hours. No charge will be made for repair and/or replacement of components at the factory for parts returned pre-paid, through the dealer and claimed within the warranty period, and found to be defective by Alfresco Gourmet Grills.

Alfresco Gourmet Grills WILL NOT cover:

- Installation or start-up
- Normal adjustment to temperature
- Damage resulting from accident, alteration, misuse, abuse, hostile environments, improper installation or installation not in accordance with local codes.
- Cleaning and/or general maintenance.
- Shipping damage
- Service by an unauthorized agency.
- Damage or repairs due to service by an unauthorized agency.
- The use of unauthorized parts.
- Overtime, weekends, holidays
- Improper installation, such as: improper hook-up, inadequate ventilation, etc

- Service visits to:
 - Correct the installation. (You are responsible for providing electrical wiring, and other connecting facilities.)
 - Repairs due to other than normal use.
 - Supply the user with operational assistance on site.

Replacement will be FOB Alfresco, Commerce California, and Alfresco will not be liable for any transportation costs, labor costs, or export duties. This warranty shall not apply, nor can we assume responsibility for damage that might result from failure to follow manufacturers instructions or local codes, where the appliance has been tampered with or altered in any way or which, to our judgment, has been subjected to misuse, negligence, or accident. Implied warranty shall not extend beyond the duration of this written warranty. This warranty is in lieu of all other warranties expressed or implied and all other obligations or liability, in connection with the sale of this appliance.

FOR SERVICE, CALL: 1 866 203 5607

When calling, please provide the following information: model number, serial number and date of installation, along with a brief description of the problem. The model number and serial number can be found on a plate located near the top of the inside left wall.

For other product information, contact: Alfresco Gourmet Grills. 7039 East Slauson Ave, Commerce, CA 90040.
Call: 1 888 383 8800 or (323) 722 7900 or fax us at (323) 726 4700.

TM

*Alfresco*TM

Open Air Culinary Systems