

VISSANI™

Item #1013989389
Model #VK-8529A

USER MANUAL

HUMIDIFIER

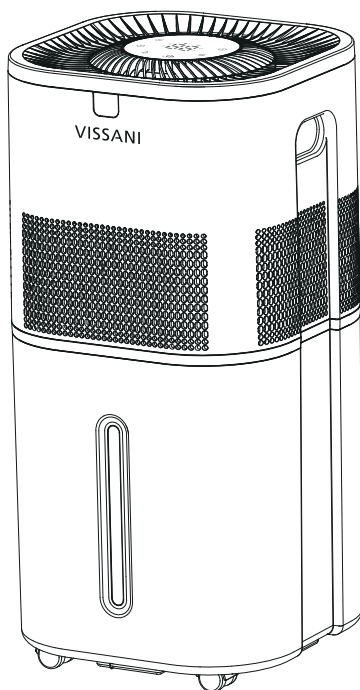

Questions, problems, missing parts? Before returning to the store,
call Vissani Customer Service
9 a.m. – 7 p.m., EST, Monday-Friday, 9 a.m. – 6 p.m., EST, Saturday
1-855-VISSANI (1-855-847-7264)
HOMEDEPOT.COM

THANK YOU

We appreciate the trust and confidence you have placed in Vissani through the purchase of this humidifier. We strive to continually create quality products designed to enhance your home. Visit us online to see our full line of products available for your home improvement needs. Thank you for choosing Vissani!

Table of Contents

Safety Information	2	Operation	6
General Safety	2	Control Panel Introduction	6
Battery.....	2	Remote Control Introduction.....	6
Power Adapter and Power Cord	3	Getting Started	7
Warranty	3	Filling & Refilling.....	8
What Is Covered	3	Using The Aroma Tray	9
What Is Not Covered	3	Change The Filter	10
Specifications	4	Assembling Casters	10
Specifications	4	Care and Maintenance	11
Package Contents	4	Cleaning	11
Parts Description	5	Cleaing The Aroma Pad	12
		Reassembling	13
		Storing	13
		Replacing The Remote Control Battery	13
		Trouble Shooting	14

Safety Information

READ AND SAVE THESE INSTRUCTIONS

GENERAL SAFETY

- Only use the humidifier as described in this manual.
- Place the humidifier and adapter properly so that it will not be knocked over.
- Do not place humidifier near to large pieces of furniture or in high-traffic areas.
- Turn off humidifier if do not use it. And disconnect from power by removing the plug from the outlet.
- Do not use the humidifier in wet environments.
- Keep the humidifier away from children.
- Do not disassemble the humidifier top or remove the water pump for self-servicing.
- Always unplug your humidifier from the power outlet before cleaning your humidifier or detaching the humidifier top from water tank.
- Always make sure to place the humidifier on a flat area before operation.
- Only fill the water tank with clean water. Never fill the water tank with any other liquids.
- Do not place the humidifier near to heat source, such as stovetops, ovens or radiators.
- Do not use other items as replacement parts for this product.
- Do not cover the air outlet while the humidifier is working, otherwise, it may damage the humidifier.
- Do not fill water from air outlet, it may damage the humidifier.
- Do not immerse the humidifier top, power cord or plug in water.
- If the humidifier is damaged or is not functioning properly, stop using it and contact Customer Service immediately (see page 1).
- Children should not clean or perform maintenance on the humidifier without supervision. Supervise children when they are near to the humidifier.
- Children should be supervised to ensure that they do not frolic with the humidifier.
- This humidifier should not to be used by persons (including children) with reduced physical, sensory or mental capacities or lack of experience and knowledge, unless they have been given supervision or instruction concerning the use of the appliance by a person responsible for the safety.

BATTERY

- Different types of batteries or new and used batteries are not to be mixed.

Safety Information (continued)

- Do not mix alkaline, standard (carbon-zinc), or rechargeable batteries.
- Alkaline batteries are recommended. Use only the specified voltage.
- Insert batteries using the correct polarity. Always use, replace, and recharge (if applicable) batteries under adult supervision.
- Do not short-circuit the battery supply terminals.
- Do not dispose of batteries in fire, batteries may explode or leak.
- Remove batteries before storing.
- Exhausted batteries are to be removed from the appliance and safely disposed off.

Do not add essential oils, other treatment liquids, or water filters into the water tank or filter. This will damage the humidifier. Only add essential oils to the aroma pad.

POWER ADAPTER AND POWER CORD

- Turn off the humidifier before removing the adapter from the outlet.
- To unplug, grab the adapter and pull from the outlet. Never pull from the power cord.
- Do not grab the power adapter and power cord with wet hands. Keep the power adapter and power cord away from liquids.
- Keep the humidifier near the outlet when it is plugged into. Using extensions cord is not recommended.
- This is a safety feature to reduce the risk of electric shock.
- If the adapter plug does not fit, reverse the plug. If it still does not fit, do not use the plug in that outlet.
- Do not bypass this safety feature.
- Please use the original adapter only; do not use any other adapters. If other adapters are used, the machine will not work or even be damaged.
- If the power adapter and power cord is damaged, please unplug it and contact Customer Service (see page 1).
- Unplugging the power adapter will disable remote control of the humidifier.



NOTE: Not for commercial use. Household use only.

Warranty

WHAT IS COVERED

Contact the Customer Service Team at 1-855-VISSANI (1-855-847-7264) or visit www.homedepot.com.

This product is warranted for two years from the date of purchase (24 months, 730 days). The warranty is limited to defects in the materials of the product and manufacturing defects.

WHAT IS NOT COVERED

- This product has exceeded the "24-month warranty".
- Failure to provide valid purchase receipts; or altered valid purchase receipts without authorization; or the model and serial numbers of the product in receipt do not match the actual product.
- The label or serial number of the product is damaged or has been tampered, or the identity of this product cannot be proved effectively.
- Unexpected factors, improper use or other human factors (including water ingress, moisture, fall down, user operation errors, transportation, bumps, etc.) caused a defect or damage; failure or damage caused by natural disasters and force majeure and so on (such as earthquakes, fires, etc.)
- Disassembled, refitted or repaired by user or an unauthorized third party.
- Not following the instructions in this manual, or damage caused by not using the original parts of the product.
- The purchaser has clearly been informed that the product is a disposed product, or samples that serve as commercial listings, or products that have been subjected to performance overload tests.
- Wear of any part, or damage to plastics and other accessories.

Warranty (continued)

All air freight and transportation costs are not covered by the warranty and must be undertaken by the customer.

In any case, the company or its authorized distributors will not grant any guarantee on time if it is beyond the control, or any special or indirect damage occurs, the company or its authorized distributors will not be responsible for it. In addition to the above-mentioned clear warranty provisions, the company is not required to assume other forms of warranty responsibilities.

Contact the Customer Service Team at 1-855-VISSANI (1-855-847-7264) or visit www.homedepot.com.

Specifications

SPECIFICATIONS

Power Supply	DC 24V-1.5A
Rated Power	30W
Water Tank Capacity	6Gallon/22.7L
Max Runtime	Up to 70 hours on low mist setting Note: The humidifier may run for a longer or shorter time depending on the environmental temperature and humidity.
Noise Level	≤50dB(High set), ≤28dB(sleep mode)
COVERAGE	2010 ft ² /187m ²
Dimensions	12.8in W x12.8in D x 26.4in H/ 32.5cm AN x 32.5cm PR x 67cm AL
Weight	11.57lbs /5.25kg

PACKAGE CONTENTS

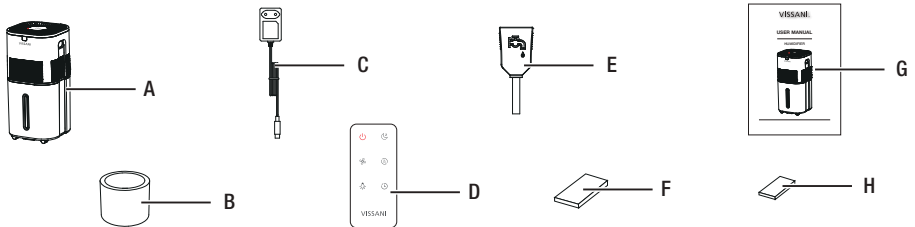

Part	Item	Quantity
A	Humidifier	1
B	Filter	1
C	Power Adapter	1
D	Remote Control	1
E	Water Filling Tube	1
F	Aroma Pad	4
G	User Manual	1
H	Water Pump Sponge	5

Pre-Installation (continued)

PARTS DESCRIPTION

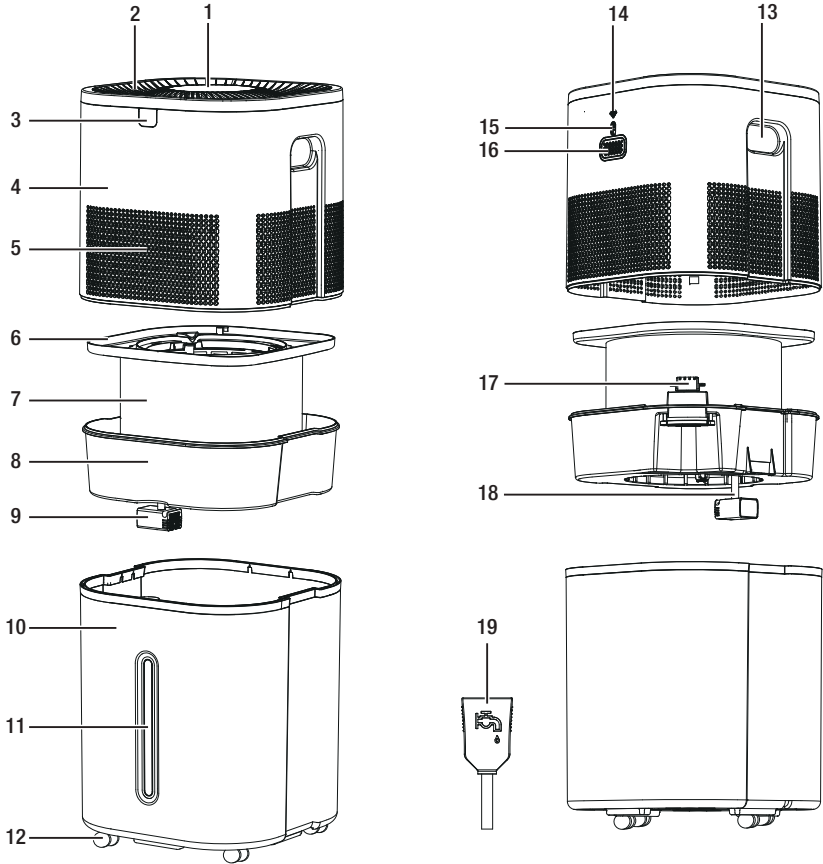

Part	Item	Part	Item
1	Control Panel	11	Water Level Window
2	Air Outlet	12	Wheel
3	Remote Receive Window	13	Handle
4	Humidifier Top	14	Humidity Sensor
5	Air Inlet	15	DC Connector
6	Drip Tray	16	Aroma Tray
7	Filter	17	Coupler
8	Filter Bracket	18	Pump Tube
9	Pump	19	Water Filling Tube
10	Water Tank		

Operation

CONTROL PANEL INTRODUCTION

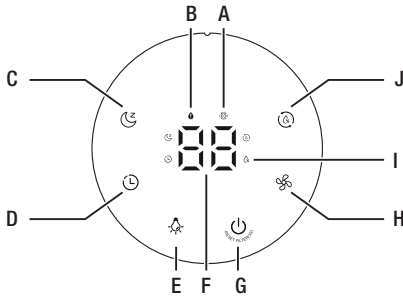

A Filter Indicator

- When drying the filter, the filter indicator is steady on. When the filter's lifespan is reached, the indicator light will flash to remind user to replace the filter.

REMOTE CONTROL INTRODUCTION

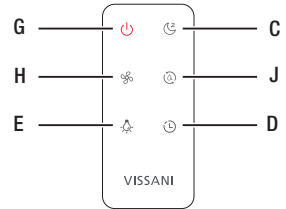

Function on remote control buttons are same as the control panel.

B Low Water Indicator

- When the water level is low the red light will flash for 30 mins and then power off if no water is added.

C Sleep Mode Button

- Tap to turn Sleep Mode on/off.

D Timer Button

- Tap repeatedly to cycle through timer setting: 0 - 14 hours, add time by 2 hours each touch.

E Light Button

- Tap to turn the all light off /return to current display.

F Digital Display

- When set the mist level or the timer, the digital display show the mist level or time level, then turn back to show humidity level after 3s not setting.

G Power Button

- Tap to turn the humidifier on/off. When turn off the humidifier, drying mode is auto on. Tap one more time, cancel the drying mode and turn off the humidifier.
- Press power button for 3s to reset the filter lifespan timing.

H Fan Speed Level

- Tap repeatedly to cycle through Fan speed level settings: 01 - 02 - 03.

I Humidity Indicator

- Shows the humidity percentage level

J Humidity Setting Button

- Tap repeatedly to cycle through the humidity setting: 50% (default) > 60% > 70% > 80% > 30% > 40% > 50%.

Operation (continued)

GETTING STARTED

1 Remove all packaging

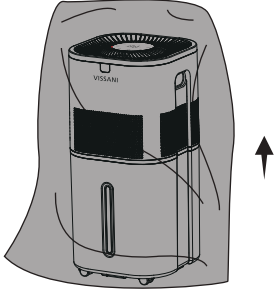

2 Remove all packaging

- Remove all tape and take the humidifier top off , and take the filter bracket out of the water tank.

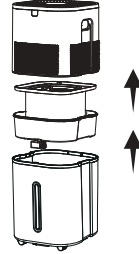

3 Clean the water tank before first use.

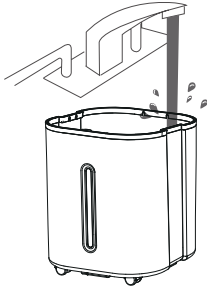

4 Choose a flat location

- Choose a stable, flat surface for the humidifier at least 12 inches /30 cm away from any walls for accurate humidity measurements. The surface must be water-resistant.

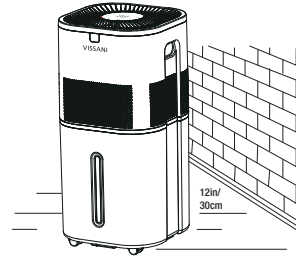

Operation (continued)

FILLING & REFILLING

1 Open the tank cover

- Remove humidifier top from the tank.

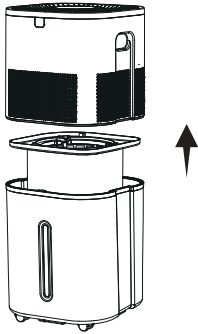

2 Fill water

- Fill the tank with faucet directly. If the faucet is too far away from the humidifier, use the water filling tube to fill the tank.

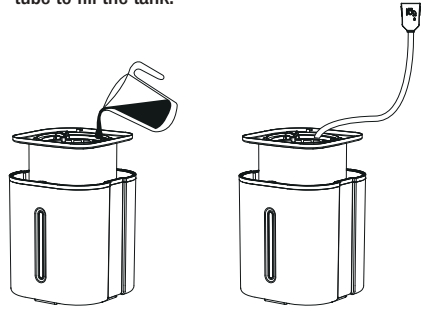

NOTE: We recommend using purified or distilled water to fill the tank.



NOTE: Do not fill past the tank's max waterline.



NOTE: Do not add water directly through air outlet .



NOTE: Do not add essential oils into the water tank.



NOTE: Only add essential oils to the aroma pad.



NOTE: Do not use water treatment liquids in this humidifier.



NOTE: Suggest to put filter and filter bracket near sink.

3 Place humidifier top on the tank.

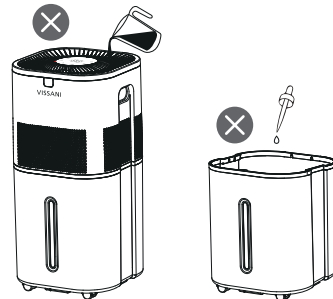
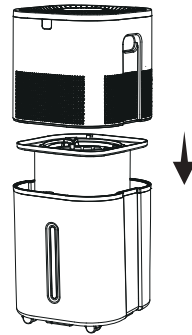

Operation (continued)

USING THE AROMA TRAY

Your humidifier can be used for aromatherapy

1 Open the aroma tray

- Push the aroma tray at the back of the base and pull it out.

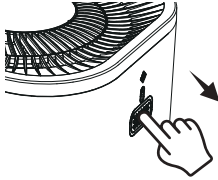

2 Adding aroma

- Put 8-10 drops of essential oil on the aroma pad.

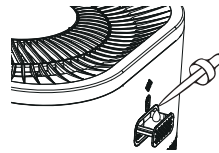

3 Close the aroma tray

- Place the aroma tray into the humidifier.

4 Start the humidifier

- Turn on the humidifier. The humidifier will automatically diffuse aroma when used.



NOTE: Do not add essential oils, water treatment liquids into the water tank.



NOTE: Only add essential oils to the aroma pad.



NOTE: The aroma pads can be cleaned and reused after diffusing essential oils.



NOTE: The aroma is intended to be light. This humidifier is not an aroma diffuser.



NOTE: Plug in the humidifier. Tap Power Button to turn your humidifier on.

Operation (continued)

CHANGING THE FILTER

1 Turn off the humidifier

- Turn off the humidifier, remove the humidifier top from the tank.

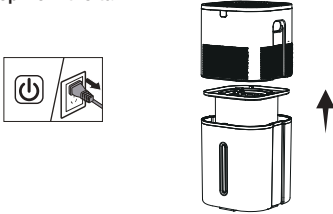

2 Rotary Unlocking

- Rotate the water drip tray clockwise, triangle mark align to unlock position.

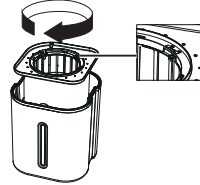

3 Change a new filter

- Remove the water drip tray off from filter bracket.
- Remove the filter from the filter bracket, change a new filter.

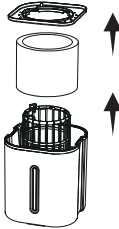

4 Rotary lock

- Place the water drip tray on the filter bracket and rotate it anticlockwise, triangle mark align to lock position.

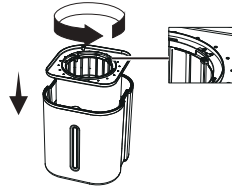

NOTE: Replace filter with Best Air H75 found on homedepot.com.

ASSEMBLING CASTERS

1 Remove casters

- Turn the water tank upside down, pull out casters from the holes.

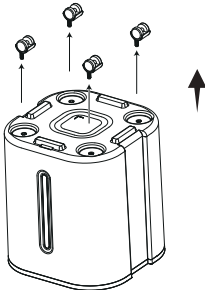

2 Assemble casters

- Turn the water tank upside down, press casters into the holes one by one.

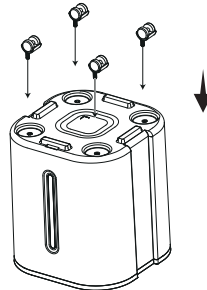

Care & Maintenance



NOTE: All maintenance should be done on a water-resistant surface, such as a kitchen counter



NOTE: Change the water every 3 days to avoid bacteria growth.



NOTE: Use a tissue or cloth to clean the water tank regularly.



NOTE: If not using the humidifier for 3 days or longer, do not leave water inside.

CLEANING

You should clean your humidifier's water tank every 3 days, and dry the filter when you're ready to store it.



NOTE: Never immerse the base in water or liquid. Do not place any part of the humidifier in dishwasher.



NOTE: Do not use detergents to clean the humidifier.

1 Turning off

- Unplug the humidifier, remove the humidifier top and filter bracket from the water tank.

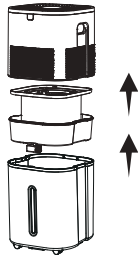
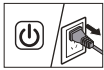

2 Rinse the water tank

- Rinse the water tank, then pour out any water from the tank.

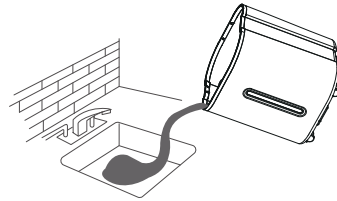

3 To descale the humidifier

- Fill the tank with 3 US cups /710 mL of distilled white vinegar.
- Swish the vinegar around the tank, soak for 15-20 minutes.
- Pull out the pump filter, outer cover, inner cover and blade
- Fill with enough vinegar to cover them. Soak for 15-20 minutes.
- Rinse all parts until any vinegar smell is completely gone.



NOTE: Do not break the ceramic shaft of the pump.

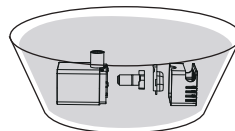
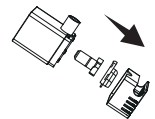
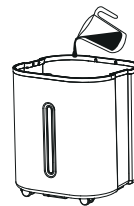

Care & Maintenance (continued)

4 Wipe and let dry

- Dry all parts with a cloth. Make sure all parts are completely dry before reassembling or storing.

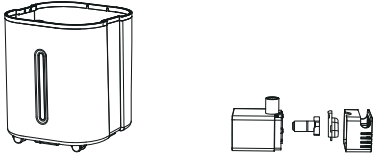

5 Reassembling

- reassembling the pump blade, inner cover, outer cover and pump filter on the pump body.

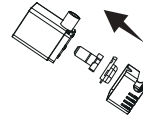

CLEANING THE AROMA PAD

1 Pull out aroma tray

- Press the aroma tray to release it from the humidifier top and pull it out.

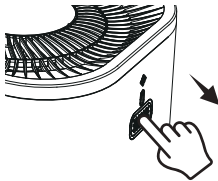

2 Cleaning the aroma tray

- Remove the aroma pad and rinse under warm, running water.

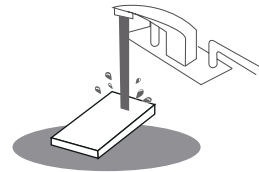

3 Close the aroma tray

- Dry with a clean cloth and place it back into the aroma tray.

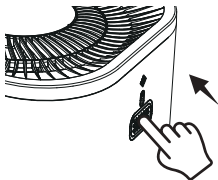

NOTE: Do not pour liquid cleaners or detergents into the aroma pad or tray.

Care & Maintenance (continued)

REASSEMBLING

1 Replace water filter bracket

- Place the water filter bracket back into the tank.

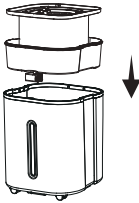

2 Replace the humidifier top

- Place the humidifier top on the tank.

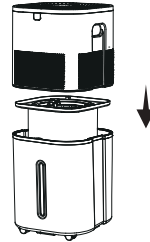

STORING

- Follow the cleaning instructions and allow all parts to dry completely before storing.
- Store in a cool, dry location.

REPLACING THE REMOTE CONTROL BATTERY

- Open the battery box cover and remove the old batteries .
- Replace the new batteries (AAA) and cover it.
- Note that the positive and negative terminals of the batteries should be aligned with the positive and negative terminals of the remote control box, do not place in reverse.

Follow the cleaning instructions and allow all parts to dry completely before storing.

Store the humidifier in a cool and dry position.

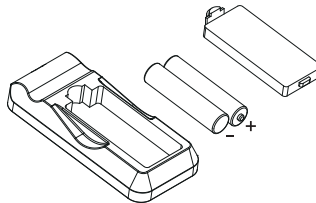
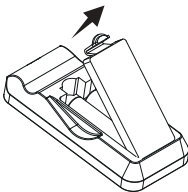

Troubleshooting

This chapter summarizes the most common problems you could encounter with the appliance. If you are unable to solve the problem with the information below, contact the Customer Service Team at 1-855-VISSANI (1-855-847-7264).

Problem	Possible Solution
Humidifier doesn't turn on, or turns off unexpectedly.	<ul style="list-style-type: none"> <input type="checkbox"/> Plug the humidifier into a working outlet and turn it on. <input type="checkbox"/> Add tap water to the water tank.
Air doesn't seem to be humid.	<ul style="list-style-type: none"> <input type="checkbox"/> Turn the fan speed to a higher setting. <input type="checkbox"/> Fill the water tank. <input type="checkbox"/> There may be too much water in the tank. Pour out some of the water from the tank. <input type="checkbox"/> Clean the humidifier (see Care & Maintenance, page 11). <input type="checkbox"/> Make sure the humidifier is on a level surface. <input type="checkbox"/> Replace a new filter with Best Air H75 found on homedepot.com. Clean the water pump sponge or replace it with a new one. Water pump sponge has five for replacement.
Humidifier uses water too quickly.	<ul style="list-style-type: none"> <input type="checkbox"/> The humidifier uses up water based on the environmental temperature and humidity. If your environment is cold and/or dry, the humidifier will run out of water faster.
Humidifier produces an unusual smell.	<ul style="list-style-type: none"> <input type="checkbox"/> If the humidifier is new, unplug and rinse all parts, then place in a cool, dry place for 12 hours. <input type="checkbox"/> Clean the humidifier (see Care & Maintenance, page 11).
Humidifier makes a loud or unusual noise.	<ul style="list-style-type: none"> <input type="checkbox"/> Make sure the water tank is properly in place. <input type="checkbox"/> Set mist level to a lower setting. <input type="checkbox"/> Empty the water tank then refill the water tank (see Filling & Refilling, page 8) <input type="checkbox"/> The humidifier may be malfunctioning. Stop using the humidifier and contact Customer Support (see page 16).
Water visibly leaks from the humidifier.	<ul style="list-style-type: none"> <input type="checkbox"/> Avoid running the humidifier in a room with over 60% relative humidity. <input type="checkbox"/> Wipe any excess water off the top and bottom of the tank. <input type="checkbox"/> Do not shake the humidifier. <input type="checkbox"/> Make sure to place the humidifier on a flat, level surface. <input type="checkbox"/> Check the water tank for leaks. If there are leaks, contact Customer Support (see page 16).
The area around the humidifier is damp or wet from condensation.	<ul style="list-style-type: none"> <input type="checkbox"/> Humidity may be too high. Turn down the fan speed, turn off the humidifier, or open a door or window to the room. <input type="checkbox"/> Open a window to ensure proper airflow for the humidifier, or move the humidifier to a more well-ventilated room. <input type="checkbox"/> Make sure the water tank is properly in place. <input type="checkbox"/> When replacing the water tank, wipe off excess water from the water tank.
Mold grows inside the humidifier.	<ul style="list-style-type: none"> <input type="checkbox"/> Clean the water tank regularly (see Care & Maintenance, page 11).
Low water Indicator lights up red.	<ul style="list-style-type: none"> <input type="checkbox"/> Fill the water tank. <input type="checkbox"/> Make sure all parts are installed correctly.
Display shows an incorrect humidity percentage.	<ul style="list-style-type: none"> <input type="checkbox"/> Moisture may have built up inside the humidity sensor. Turn off the humidifier and allow the sensor to air dry. <input type="checkbox"/> If the humidifier is placed within 12 inches/30 cm of a wall or in a corner, the humidity sensor cannot provide a proper reading for the relative humidity in the room. <input type="checkbox"/> The humidity sensor will give an improper reading if it is exposed to dust. Avoid using the humidifier in dusty rooms.

Troubleshooting (continued)

Problem	Possible Cause
The humidity level isn't changing in my room.	<input type="checkbox"/> Use a higher fan speed setting.
	<input type="checkbox"/> Depending on your environment, the humidifier may take longer to humidify your air.

This chapter summarizes the most common problems you could encounter with the appliance. If you are unable to solve the problem with the information below, contact the Customer Service Team at 1-855-847-7264.

Problem Possible Cause Solution
 HOMEDEPOT.COM

Please contact 1-855-VISSANI (1-855-847-7264) for further assistance.

FCC SUPPLIER'S DECLARATION OF CONFORMITY

Product information	
Product Name:	Humidifier
Model No.:	VK-8529A
Trade Mark:	VISSANI
Applicable standards:	FCC CFR Title 47 part 18 Subpart B
The following responsible party designated in FCC §2.909 is responsible for this declaration:	
Company Name:	HOME DEPOT
Address:	2455 PACES FERRY ROAD ATLANTA, GA 30339
Telephone Number:	1 -855-VISSANI (1-855-847-7264)

This device complies with part 18 of the FCC Rules.

Information to the user:

Information on the following matters shall be provided to the user in the instruction manual or on the packaging if an instruction manual is not provided for any type of ISM equipment:

- The interference potential of the device or system.
- Maintenance of the system.
- Simple measures that can be taken by the user to correct interference.
- Manufacturers of RF lighting devices must provide an advisory statement, either on the product packaging or with other user documentation, similar to the following: This product may cause interference to radio equipment and should not be installed near maritime safety communications equipment or other critical navigation or communication equipment operating between 0.45-30MHz. Variations of this language are permitted provided all the points of the statement are addressed and may be presented in any legible font or text style.

VISSANI™

Questions, problems, missing parts? Before returning to the store,
call Vissani Customer Service
9 a.m. – 7 p.m., EST, Monday-Friday, 9 a.m. – 6 p.m., EST, Saturday
1-855-VISSANI (1-855-847-7264)
HOMEDEPOT.COM
Retain this manual for future use.