

USER AND MAINTENANCE MANUAL



IMPORTANT: documents included in this manual to be kept:

- "CE" COMPLIANCE DECLARATION
- WARRANTY CERTIFICATE



Read the user instructions before unpacking the appliance.

Coffee grinders - Fruit juicers - Mixers - Blenders - Drinks dispensers - Planetary mixers
Cheese graters - Ice crushers - Grinders - Vegetable slicers – Dough mixer
Moulins à café - Presse-fruits - Mixers - Blenders - Distributeurs de boissons - Batteurs
mélangeurs - Pétrin - Râpes à fromage - Broyeurs à glaçons - Hache-viande - Coupe-légumes

MODELES DEPOSES FRANCE ET INTERNATIONAL
INTERNATIONALLY PATENTED MODELS



CONTENTS

“CE” COMPLIANCE DECLARATION	3
SAFETY INSTRUCTIONS	4
INSTALLATION AND HANDLING	4
IMPORTANT RESTRICTIONS:	4
ELECTRICAL CONNECTION:	4
USING FOR THE 1st TIME	5
RECYCLING THE PRODUCT AT THE END OF ITS SERVICE LIFE	5
DESCRIPTION OF THE APPLIANCE	6
USING THE APPLIANCE	6
STARTING WORK:	6
CHANGING THE TOOL	8
CLEANING:	8
SAFETY / MAINTENANCE	9
SAFETY DEVICES	9
Bowl presence safety device:	9
"Motor overload" safety feature:	9
"Motor overheating" safety feature:	9
"Tool access" safety feature:	9
MAINTENANCE	10
Spare parts:	10
Changing a worn belt on the variable speed drive (replacement after breaking)	10
Fitting the new variable speed drive belt	10
FAULT FINDING	12
The appliance will not start:	12
The appliance stops after the motor has overheated:	12
The appliance stops following an overload:	12
The tool no longer rotates and the lamp on the switch (13) is lit:	12
APPLIANCE TECHNICAL SPECIFICATIONS	13
Electrical diagrams	14
110-120V 50/60Hz wiring diagram	14
380V / 220V 50Hz three-phase wiring diagram	15
220-240V 50/60Hz wiring diagram	16
Figures	18
WARRANTY CERTIFICATE	19
APPLIANCE IDENTIFICATION PLATE	19



"CE" COMPLIANCE DECLARATION

THE MANUFACTURER:

SANTOS sas - 140-150, Av. Roger SALENGRO 69120 VAULX-EN-VELIN (LYON)
FRANCE

declares that the appliance intended for the professional market described below:

Description: **PLANETARY MIXER**
Type number: **27**

complies with:

- the statutory provisions defined in appendix 1 of the European "machines" directive **n°2006/42/CE** and the national legislation transposing it
- the statutory provisions of the following European directives and regulations:
 - N° 2006/95/CE (low voltage directive)
 - N° 2004/108/CE (EMC directive)
 - No. 2002/95/CE (RoHS directive)
 - No. 2002/96/CE (WEEE directive)
 - N° 1935/2004/CE (regulation) relating to materials and articles intended to come into contact with foodstuffs

Harmonised European standards used to give presumption of conformity with the essential requirements of the above-mentioned directives:

- **NF EN 454+A1: 2010**, Food processing machinery – **beater mixers** - Safety and hygiene requirements.
This European standard is a type-C standard as defined in EN ISO 12100. When the provisions of this type-C standard differ from those stated in the type-A or B standards, the provisions of the type-C standard override the provisions of the other standards. This standard provides the means to comply with the requirements of the "machines" directive n°2006/42/CE, (see appendix ZA)
- **NF EN ISO 12100 -1 and 2:2004**: Safety of machinery - General principles for design
- **NF EN 60204-1: 2006** : Safety of machinery - Electrical equipment of machines- General requirements
- **NF EN 1672-2: 2005**, Food processing machinery – Basic concepts – Hygiene requirements
- **NF EN 60335-1: 2003** : Household and similar electrical appliances. Safety.
- **NF EN 60335-2-64 :2004** : Particular requirements for commercial electric kitchen machines

Drawn up in VAULX-EN-VELIN on: **01/01/2010**
Signatory's position: **CHIEF EXECUTIVE OFFICER**
Signatory's name: **Aurélien FOUQUET**

Signature:

SAFETY INSTRUCTIONS

When using, maintaining or scrapping the appliance, take care to comply fully with the following elementary precautions.

Read the explanatory leaflet in full

Note: In order to make it easier to understand the following paragraphs, please refer to the diagrams given towards the end of the manual

INSTALLATION AND HANDLING



It is forbidden to pick up the appliance using the levers, control handles or protective grid.

The machine can be handled by a single person.
For ease of use, it is recommended that the machine is placed on a table or work surface to make it easy to add ingredients or to check on progress with processing (recommended height: 90 cm, to be adapted according to the user).

IMPORTANT RESTRICTIONS:



1. The appliance is designed exclusively for beating, mixing, or whisking foodstuffs.
2. The appliance is not designed for processing frozen foods.
3. The machine must not be left to operate without supervision.
4. Neither a hose nor a pressure hose should be used for cleaning
5. In order to protect against the risk of electrocution, do not put the base in water or any other liquid.
6. Unplug the appliance before any intervention on it: cleaning, general care, maintenance.
7. Use of spare parts other than certified original SANTOS parts is prohibited

ELECTRICAL CONNECTION:

- The electric power supply for the appliance is available in 2 single-phase voltages and a three-phase version:
 - 110-120 V 50/60 Hz:
 - 220-240 V 50/60 Hz:
 - 220V and 380V 50Hz three phase

Line protection: the appliance must be connected to a standard socket 2 poles + ground (for the single-phase versions).

The set-up must be fitted with a differential circuit breaker and a 16A fuse. **The earthing of the appliance is compulsory.**

TAKE CARE:



- Before connecting the machine, check that the mains electrical voltage is the same as the voltage for your appliance. Its value is shown:
 - either on the identification plate under the machine.
 - or on the identification plate on the last page of this manual.

- If the power cable (8) is damaged, it should be replaced by a special assembly available from approved SANTOS dealers or from SANTOS.

USING FOR THE 1st TIME

1. Pull the lever (1) forwards to unlock and lower the bowl (2)
2. Remove the bowl support (3), bowl (2) and accessories in their wrappings,
3. Remove, unwrap and wash the three tools in clean water,
4. Wash all the elements in contact with food in clean water: the bowl (2), the inside part of the bowl centering device (4).

RECYCLING THE PRODUCT AT THE END OF ITS SERVICE LIFE



This appliance is marked with the waste sorting symbol concerning scrap electrical and electronic equipment. This means that the product must be disposed of via a selective waste sorting system in accordance with directive 2002/96/CE (DEEE) – Professional Appliances section – so that it can be either recycled or dismantled in order to reduce any impact on the environment.

For further information you can contact your dealer or SANTOS.

For the disposal or recycling of the appliance components, please refer to a specialist company or contact SANTOS.

Electronic items that have not been through the selective waste sorting system present a potential danger for the environment.

The packaging material should be disposed of or recycled in accordance with regulations in force.



DESCRIPTION OF THE APPLIANCE

The beater-mixer can be used to beat, mix and whisk preparations made by professionals in restaurants, pizza houses, snack bars, catering outlets, sandwich bars, special theme restaurants, etc.

The appliance consists of an aluminium body and stainless steel plating.

Thanks to the asynchronous motor, it can operate with a **hook**, **paddle**, or a **whisk** (delivered as standard with the appliance). The working part of the hook and whisk is made of stainless steel, while the working part of the paddle is made of food quality aluminium.

3 types of tools

- **Hook (5):** for products that are difficult to process such as bread dough, pizza doughs, pastry doughs etc.
- **Paddle (6):** for products that need to be mixed and made homogeneous such as pancake batter, waffle batter, cake mix, choux pastry dough, kneading of meat and fish preparations, purees, various mixes, etc.,.
- **Whisk (7):** for light products that need to be mixed and made homogeneous such as sponge batters, meringues, butter creams, mayonnaise, whisked egg whites, various light mixtures, etc.

Bowl made of stainless steel, capacity 9.9 liters, useful capacity 8 liters (e.g. for pancake batters)

USING THE APPLIANCE

STARTING WORK:

1. After selecting the appropriate tool for the work to be done (hook (5), paddle (6) or whisk (7)), you can:
 - a. either fit the tool to the rotating shaft by locking the bayonet system in place, then install the bowl (2) with or without the products to be processed in it, on the bowl support (3),
 - b. or install the bowl (2) with or without the products to be processed in it, on the bowl support (3) then fit the tool to the rotating shaft by locking the bayonet system in place.
2. Push the handle (1) backwards to raise the bowl (2).
3. When the handle (1) reaches its end of travel, the bowl (2) is locked in position.
4. Connect the supply cord plug (8) to your mains supply socket.
5. Put the products to be processed in the bowl (2), if this hasn't already been done. To do this, the safety grid (9) has to be lifted.
6. Select the speed lever (10) position according to the work to be done and the desired speed. Put the lever (10) in one of the 8 notches in the rack (11) to the right of the column (12). The first notches towards the front are for high speeds



- (whisking), those in the middle for medium speeds (work with the paddle), and the furthestmost notches for slow speeds (work with the hook).
7. The grid must be down and the bowl in the raised position before starting the appliance by putting the on/off switch (13) to position 1; the lamp should light up.
 8. When the preparation is ready, stop the machine:
 - a. either by putting the On / Off switch (13) to the 0 position,
 - b. or by pressing the red "mushroom-head" switch (14).
 9. Pull the handle (1) forwards to lower the bowl (2).
 10. Then either remove the tool from the rotating shaft by unlocking the bayonet system then remove the bowl (2), or remove the bowl (2) then remove the tool from the rotating shaft by unlocking the bayonet system.

HOW TO STOP THE MACHINE

The machine can be stopped in several ways:

- by using the On / Off switch (13),
- or by pressing the red "mushroom-head" switch (14).
- or by raising the safety grid (9),
- or by unlocking the bowl (2)

ADDING INGREDIENTS DURING PROCESSING

You can add further ingredients (flour, eggs, oil, etc) during processing.

How to do this:

- either through the safety grid (9) with the appliance running,
- or by stopping the machine by raising the safety grid (9). To start the appliance up again, the safety grid (9) must be lowered.



TAKE CARE: Scattering of flour dust when loading or starting the appliance is dangerous for health. It is recommended to fill the bowl gradually (at an even rate), and even to use a protective mask in reduce any inhalation of flour dust to a minimum.



CHANGING THE TOOL

All tool changes must be carried out with the appliance halted and the bowl support in the lowered position.

FITTING:

1. Place the tool on the rotating shaft (**16**)
2. Push the tool upwards,
3. Turn and lift the tool slightly anticlockwise in order to engage the pin bayonet on the tool rotation shaft (**16**).

REMOVING:

1. Do the same operations as for fitting, in reverse.

CLEANING:

IMPORTANT:



- **Stop the appliance and unplug its power cable from the mains.**
- **Cleaning with a jet of water or by pressure is not allowed.**

It is recommended to clean the appliance as soon as you have finished using it. It will be easier to clean if you do not allow the remaining scraps of food to dry.

- Clean the tool (hook, paddle or whisk) after use with water or a detergent made for dish washing. Then rinse and dry.
- Clean the stainless steel bowl after use with water or a detergent made for dish washing. Do not use abrasive products or pads to clean the bowl.
- Clean those parts of the frame in contact with the food using water or a detergent made for that purpose. Then rinse and dry.
- The base (**24**) is to be cleaned with a soft damp sponge, then dried.

SAFETY / MAINTENANCE

SAFETY DEVICES



If the problem persists, switch off the power supply to the machine (unplug the cord from the mains socket (8)) and call in the maintenance service or contact a SANTOS approved dealer.

Bowl presence safety device:

1. The bowl (2) must be centered and held firmly in the upper position between the bowl support (3) and the machine frame (4) before the appliance is allowed to work.
2. The bowl must be present to allow the appliance to be started.
3. When the bowl (2) is unlocked, this stops the appliance.
4. A cut in the mains power supply results in the On / Off switch (13) stopping (position 0).
5. Re-starting the beater-mixer requires specific operation of the On / Off switch (13) again (position 1).

"Motor overload" safety feature:

Should the motor (15) become blocked (foreign body, object that is too hard) the On / Off switch (13) automatically trips to the 0 position.

Correct the problem and press the On / Off switch (13) (position 1).

"Motor overheating" safety feature:

If the motor overheats, the On / Off switch (13) automatically trips to the 0 position. Wait for the motor to cool (15 to 30 minutes), then push the On / Off switch (13) (position 1).

"Tool access" safety feature:

The beater-mixer can only start when the safety grid (9) is in the lowered position.

When the safety grid (9) is closed, there is no access to the tools in the bowl during processing operations.

The safety grid does however allow products to be added during operation without having to raise it.

MAINTENANCE

Prior to carrying out any intervention on the appliance, it must be disconnected from the mains without fail.

Discharging the capacitor:



Use a screwdriver with insulated handle to touch the 2 connectors on the capacitor (19). The appearance of an electric arc shows that the capacitor has discharged.

Spare parts:



IMPORTANT: Use of spare parts other than certified original SANTOS parts is prohibited

This machine requires no specific maintenance. The bearings are lubricated for life. If work is required to replace worn parts such as transmission belt, tools, or the electric or other components, refer to the parts list (see exploded view at the end of the manual).

For **all spare part orders** (see references in the exploded view at the end of the manual), state:

- **the type,**
- **the machine serial number and**
- **the electrical characteristics**

marked under the machine.

Changing a worn belt on the variable speed drive (replacement after breaking)

Before proceeding with the variable speed drive belt (20) change it is recommended to stop the beater-mixer at slow speed.

1. Disconnect the appliance from the mains.
2. Unscrew the locking screw (17) and remove the cover (18).
3. Discharge the starter capacitor (19).
4. Lift the belt (20) to disengage it from the driven pulley (21) (turn the pulley by hand to make it easier to remove the belt).
5. Disengage the belt (20) from the drive pulley (22) and remove the belt from the beater-mixer.

Fitting the new variable speed drive belt

1. Fit the new belt (20) on the drive pulley (22).
2. Lift the belt (20) to fit it on the driven pulley (21) (turn the pulley by hand to make it easier to engage the belt).

3. After installing the belt (20), turn the driven pulley (21) by hand and gradually pull the speed control lever (10) until it reaches the high speed position.
4. Once in this position, check the distance for the top of the belt at the outer diameter of the drive pulley (21) (minimum distance 39 mm, maximum 40 mm): see the sketch.

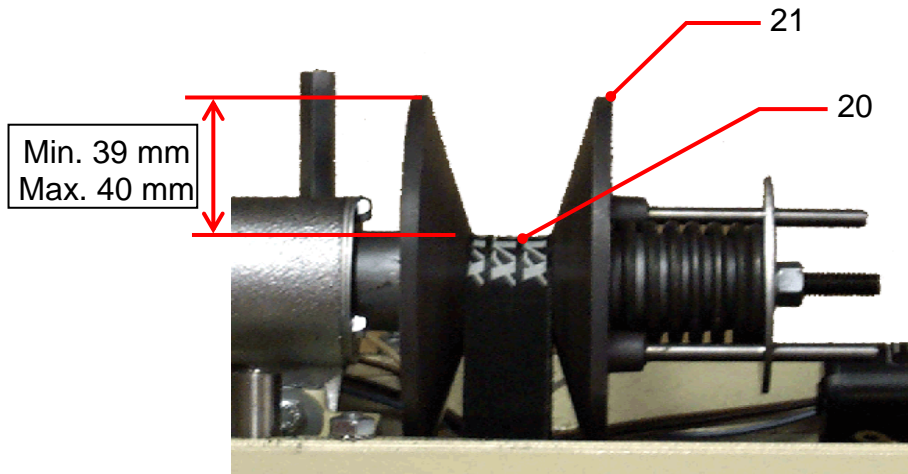

- If the distance measured is correct, then the belt (20) change operations are finished. All that is needed is to carry out the following operations.

Replace the cover (18) and screw the locking screw home (17).

Connect the appliance to the mains electricity supply and start the beater-mixer, then change the speed a few times to check that the variable speed drive operates correctly over the whole range of speeds.

- If the distance measured is outside the tolerances, the rack (11) for the speed control level (10) must be adjusted as follows.
 1. Loosen the two screws (23) fixing the rack (11) and move the rack forwards if the distance measured is less than 39 mm, or backwards if the distance exceeds 40 mm.
 2. Turn the driven pulley (21) by hand and check the belt position measurement.
 3. Continue in this manner until a suitable measurement is obtained, then screw home the two screws (23) fixing the rack in position (11).
 4. Move the speed control lever (10) to the low speed position and turn the driven pulley (21) by hand to check the position of the belt in the pulley: the belt must never protrude beyond the outer diameter of the pulley.
 5. Replace the cover (18) and screw the locking screw home (17).
 6. Connect the appliance to the mains electricity supply and start the beater-mixer, then change the speed a few times to check that the variable speed drive operates correctly over the whole range of speeds.

FAULT FINDING



Identifying the cause of appliance stoppage with precision.

If the problem persists, switch off the power supply to the appliance (unplug the cable from the mains socket) and call in the maintenance service or contact a SANTOS approved dealer.

The appliance will not start:

- Check : that the grid is in the low position, and that the bowl is locked in the up position
- Check : the mains supply, the condition of the supply cord and plug,
- Check that the On/Off lamp (13) lights up when the switch is at position "1-On".
- Call in a specialist technician to check the appliance's electrical components.

The appliance stops after the motor has overheated:

(the metal casing around the speed change lever is hot)

- Press the "mushroom-head switch" (14), disconnect the appliance from the mains socket and follow the instructions in the "motor overheating safety feature" section

The appliance stops following an overload:

- If the motor stalls during operation, see the "motor overload safety feature" section

The tool no longer rotates and the lamp on the switch (13) is lit:

- press the "mushroom-head" switch (14), disconnect the appliance from the mains socket and check the condition of the belt (20), see the "Maintenance / belt change" section.

APPLIANCE TECHNICAL SPECIFICATIONS

Mains:					
Power supply voltage (V)	220-240	110-120	220-240	220-240 Three-phase	380 Three-phase
Frequency (Hz)	50	60	60	50	50
Start capacitor (μ F)	150-190V	250-130V	150-190V		
Motor					
Rating (kW)	0,6	0,65	0,65	0,51	0,51
Motor speed (rpm)	1500	1800	1800	1500	1500
Number of speeds:					
Min. planetary speed (rpm)	50	60	60	50	50
Max. planetary speed (rpm)	150	180	180	150	150
Min. tool speed (rpm)	180	210	210	180	180
Max. tool speed (rpm)	540	640	640	540	540
Noise: (2) L_{pA} uncertainty $K_{pA} = 2.5dB$	65	65	65	65	65
Dimensions and weight					
Height (mm)	585				
Width (mm)	340				
Depth (mm)	570				
Net weight (kg)	30				
Packaged weight (kg)	34				
Bowl Volume (l)	9,9				
Useful volume (l)	8				

- (1) These ratings are given for your guidance. The exact electrical specifications of your appliance can be found on the rating plate.
- (2) Noise level measured in terms of acoustic pressure with the machine loaded according to standards ISO 11201:1995 and ISO 4871:1996.
Appliance placed on a work surface 75cm above the ground. Microphone turned towards the appliance at 1.6m from the ground and 1m from the appliance.

Electrical diagrams

110-120V 50/60Hz wiring diagram

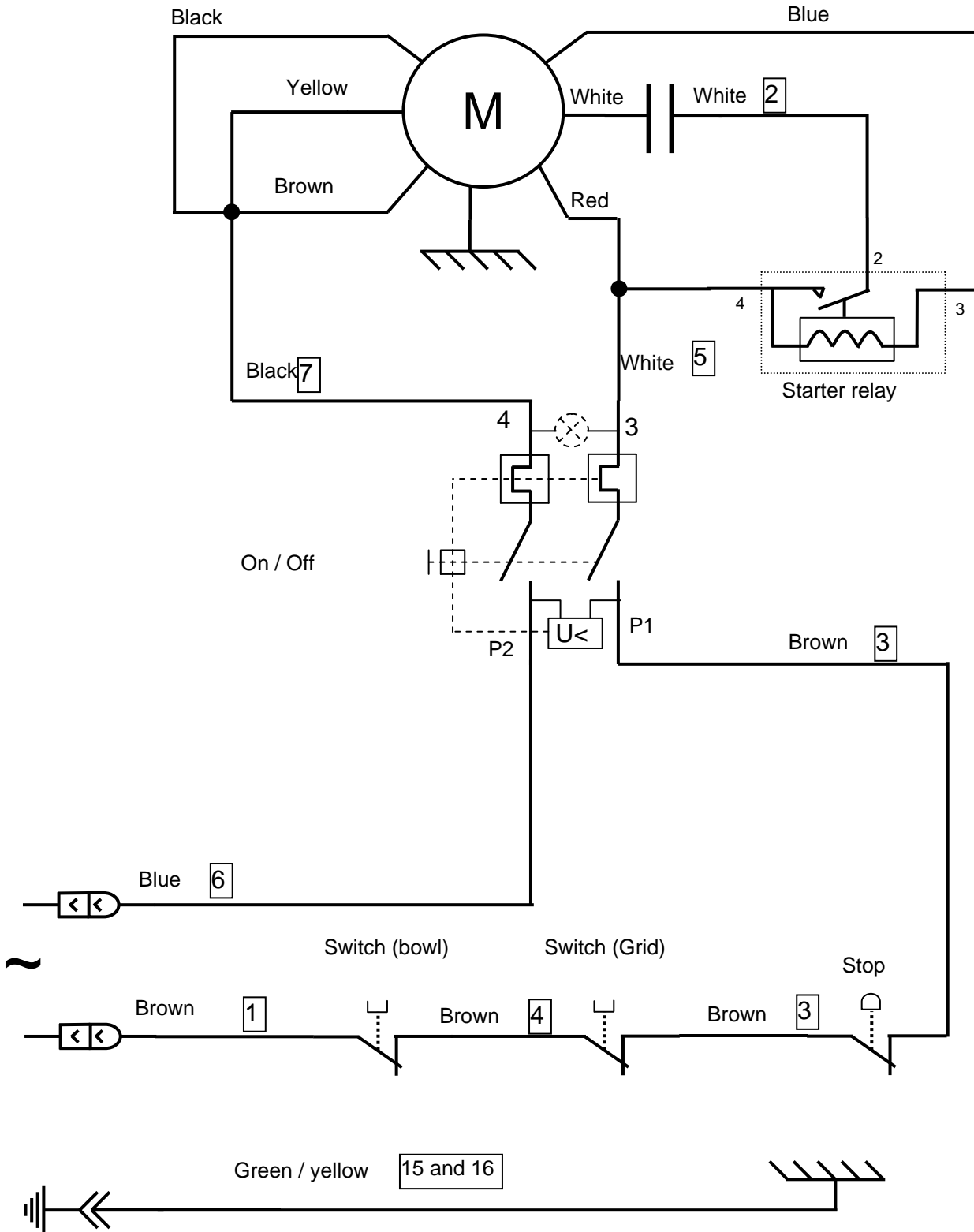

380V / 220V 50Hz three-phase wiring diagram

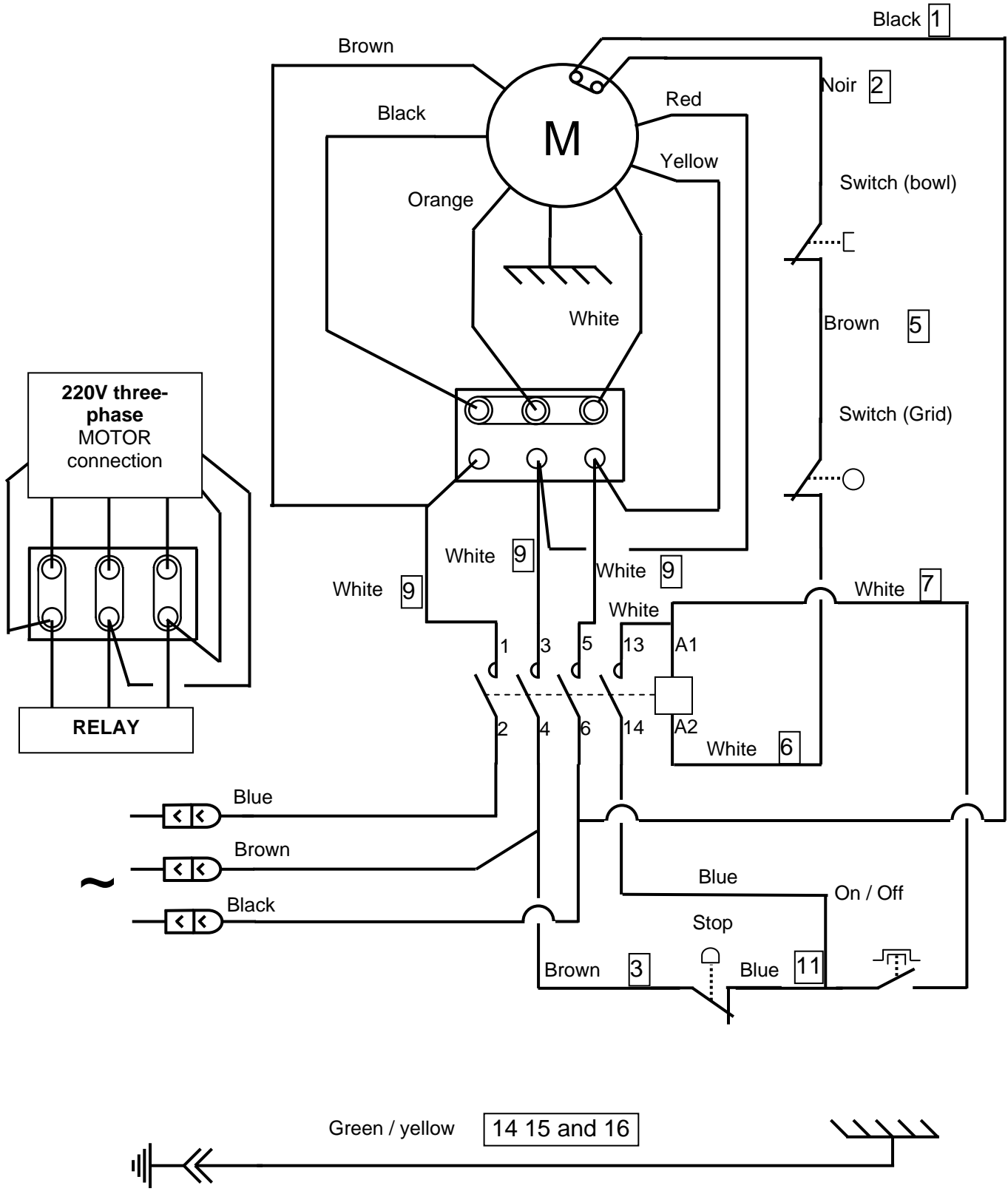

220-240V 50/60Hz wiring diagram

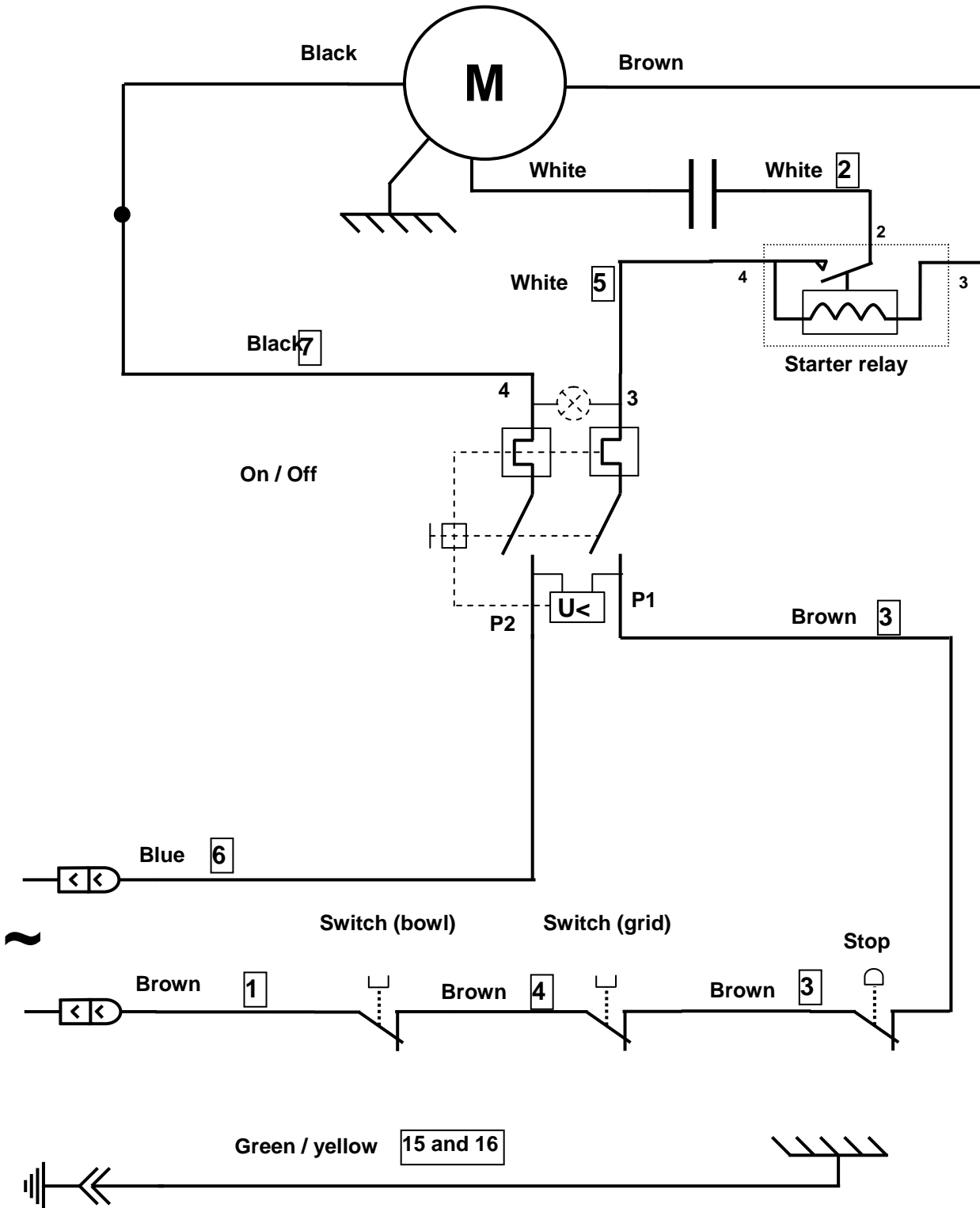



item	F
1	Locking lever
2	Bowl
3	Bowl support
4	Bowl centering device
5	"Hook" tool
6	"Paddle" tool
7	"Whisk" tool
8	Mains power cable
9	Grid
10	Speed control lever
11	Rack
12	Column
13	On-Off switch
14	"Mushroom-head" switch
15	Motor
16	Tool shaft
17	Cover fixing screw
18	Cover
19	Capacitor
20	Belt
21	Variable speed pulley
22	Drive pulley
23	Rack fixing screw
24	Base

Figures

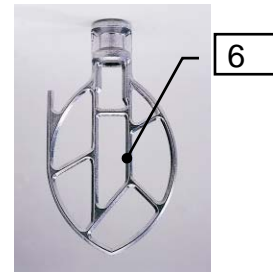
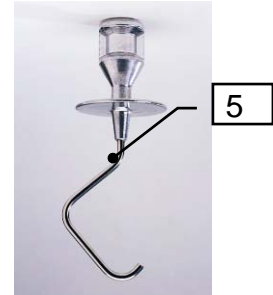
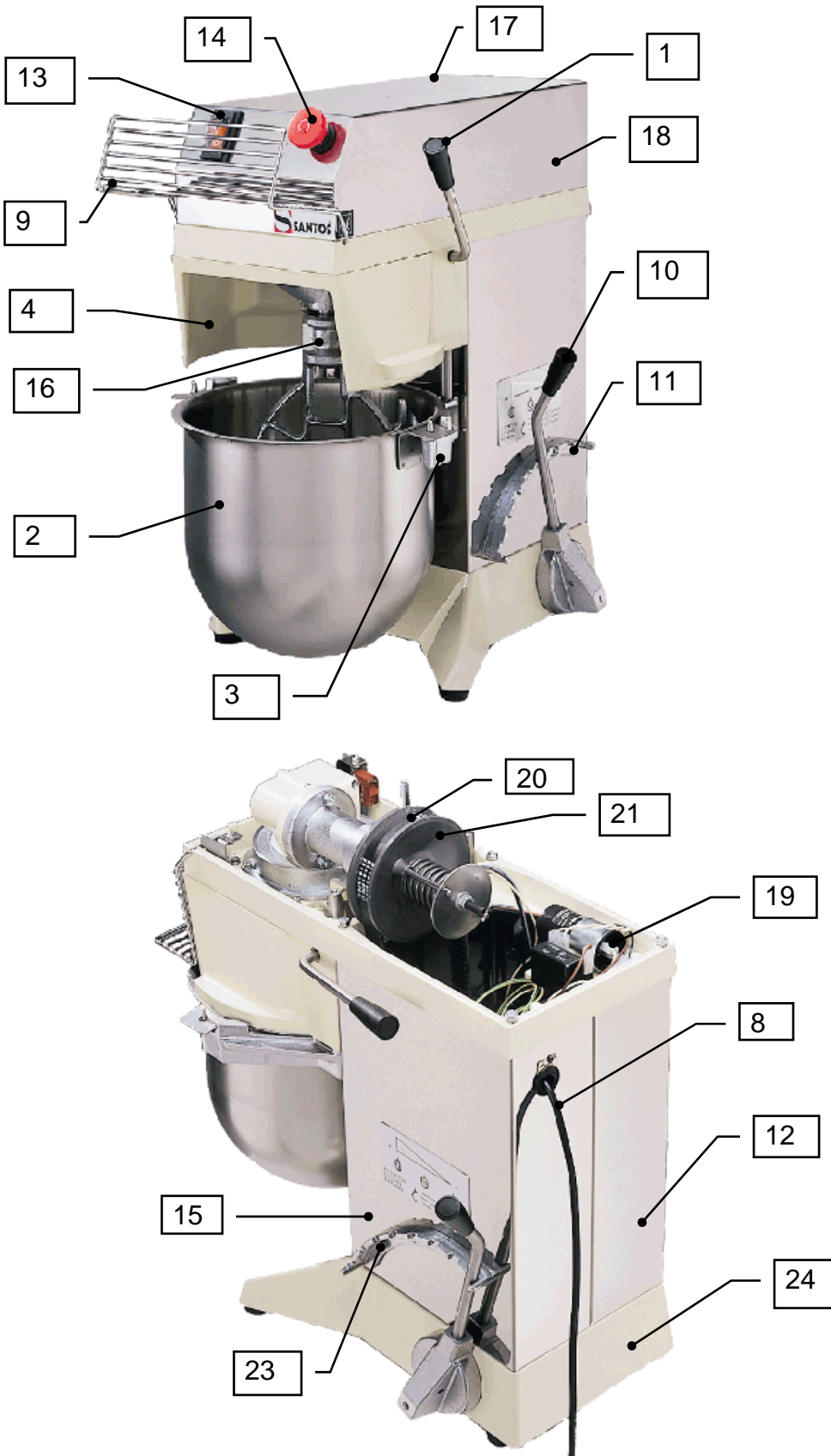



WARRANTY CERTIFICATE

WARRANTY

Since the 01.01.95, all our appliances comply with CE and possess the CE label. Our guarantee is of 24 months from the manufacturing date mentioned on the descriptive plate, except concerning the asynchronous motors (consisting of a rotor and a stator) which are warranted for 5 years from their manufacturing date. Warranty is strictly limited to the free replacement of any part of origin recognized by us as defective due to a defect or building default and identified as belonging to the concerned appliance. Warranty does not apply to damages resulting from installation or use non-complying with our appliance data sheet (user's manual) or in case of an evident lack of maintenance or disrespect of elementary security electric rules. It does not apply in case of regular wear and tear. Any replacement of parts under warranty will be realized after return of the defective part in our workshops, postage paid, supported by a copy of a conformity statement on which appears the serial number of the appliance. Every appliance is equipped with a descriptive plate conforming to the EC recommendations and of which a duplicate exists in the conformity statement (serial number, manufacturing date, electrical characteristics ...). In case of serious damage judged repairable only in our workshops, and after prior consent from our departments, any appliance under guarantee is sent by the Distributor, carriage paid. In case of repairs or reconditioning of appliances not under guarantee, the round trip transport is payable by the distributor. The parts and workforce are invoiced at the current rate. A preliminary estimate can be supplied.

Coffee grinder not using SANTOS original burrs are not taken under guarantee. The warranty conditions, repairs, reconditioning, of the espresso coffee grinder are the object of a specific note. Our guarantee does not extend to the payment of penalties, the repair of direct or indirect damages and notably to any loss of income resulting from the nonconformity or the defectiveness of products, SANTOS's global responsibility being limited to the sale price of the delivered product and to the possible repair of the defective products.

In case of revelation of an imperfection during the warranty period, the Distributor has to, unless a different written agreement of SANTOS, indicate to his customer to stop any use of the defective product. Such a use would release SANTOS of any responsibility.

APPLIANCE IDENTIFICATION PLATE

