



Lixel Holo 1

Light 1224

Light 1224

User Manual

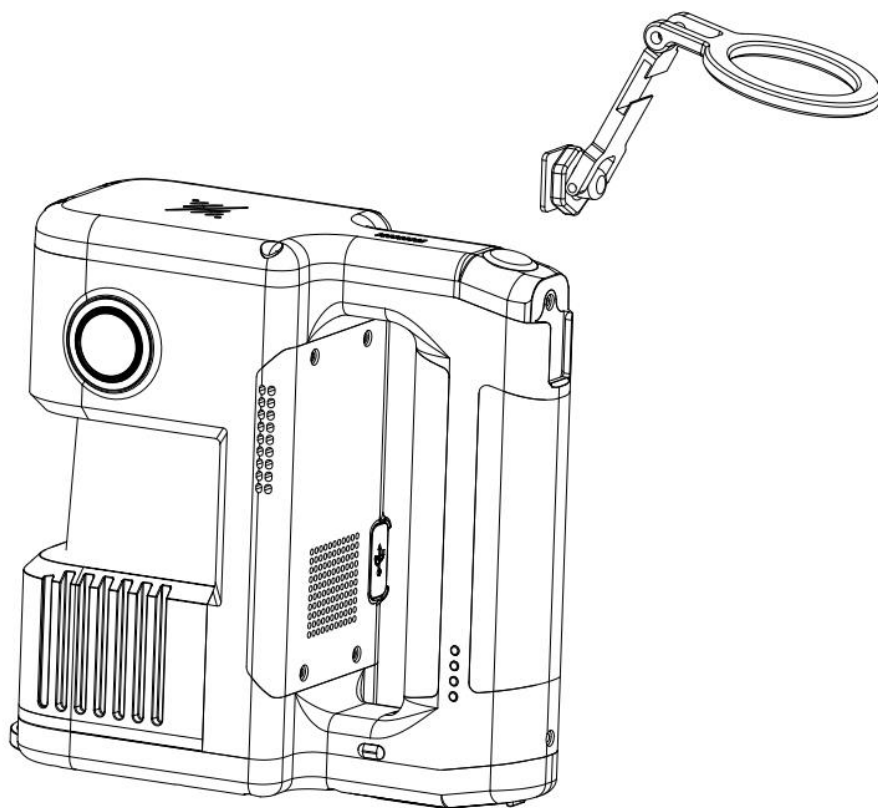

Light 1224

Light 1224

—: Product Overview

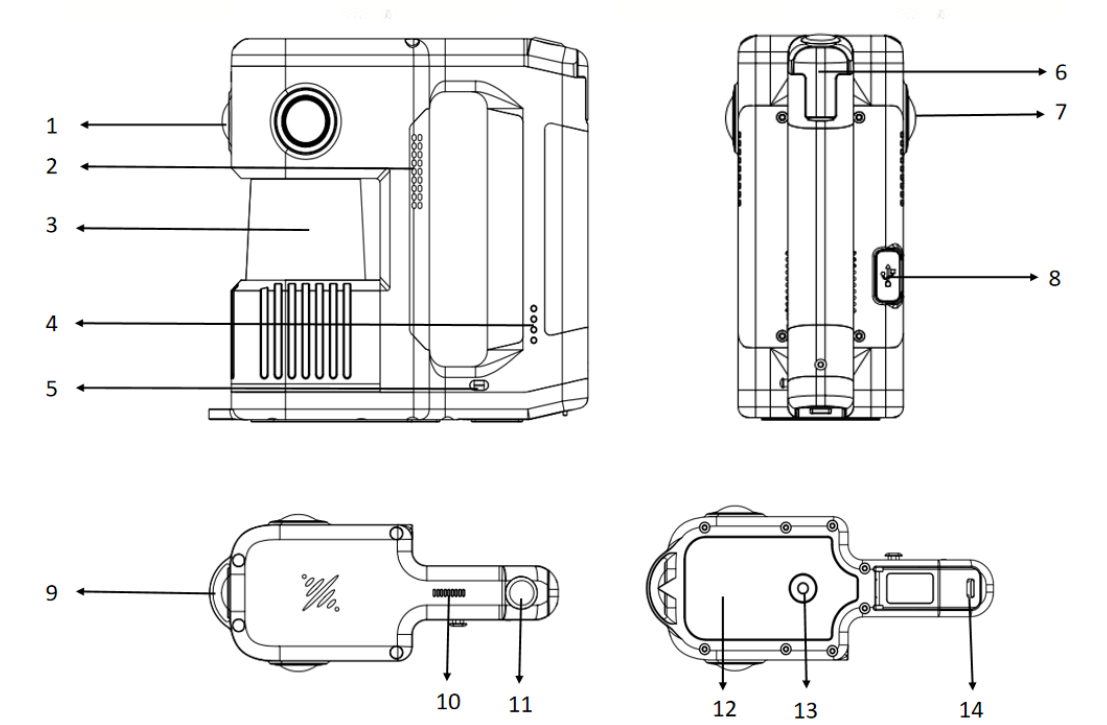

1: Front camera	2: Air outlet
3: LiDAR	4: Battery indicator light
5: Battery eject button	6: Cold shoe mount
7: Fisheye camera	8: USB port (cannot charge the battery)
9: Control point base	10: Sound outlet
11: Power button	12: Non-slip heat insulation pad
13: 1/4-inch port	14: Battery base bayonet

1. When the device is powered on, it enters the normal power consumption mode. If no scanning operation is initiated within 5 minutes, the device switches to low power consumption mode, where its power consumption is approximately one-third of that in normal mode. In low power mode, the LiDAR does not operate, but data can still be copied. After data collection is completed, the device will also enter low

power mode if it remains idle for 5 minutes after scanning is stopped.

2. The device will emit an audible alert when powered on, powered off, when the battery level is below 20%, and when below 10%. During recording, if the battery level drops below 10%, the device will forcibly stop recording and save the data. When the battery level is below 5%, the device will automatically power off to protect itself.
3. If the battery level is below 10%, the device will not power on when the battery is installed.
4. If the battery level displayed on the APP is abnormal, it may be that the battery is not properly inserted. Please press the buckles on both sides of the battery into place and check whether the battery level is normal again.

二： Basic Functions of the Equipment

2.1、 Battery Installation and Charging

1、 Battery Installation

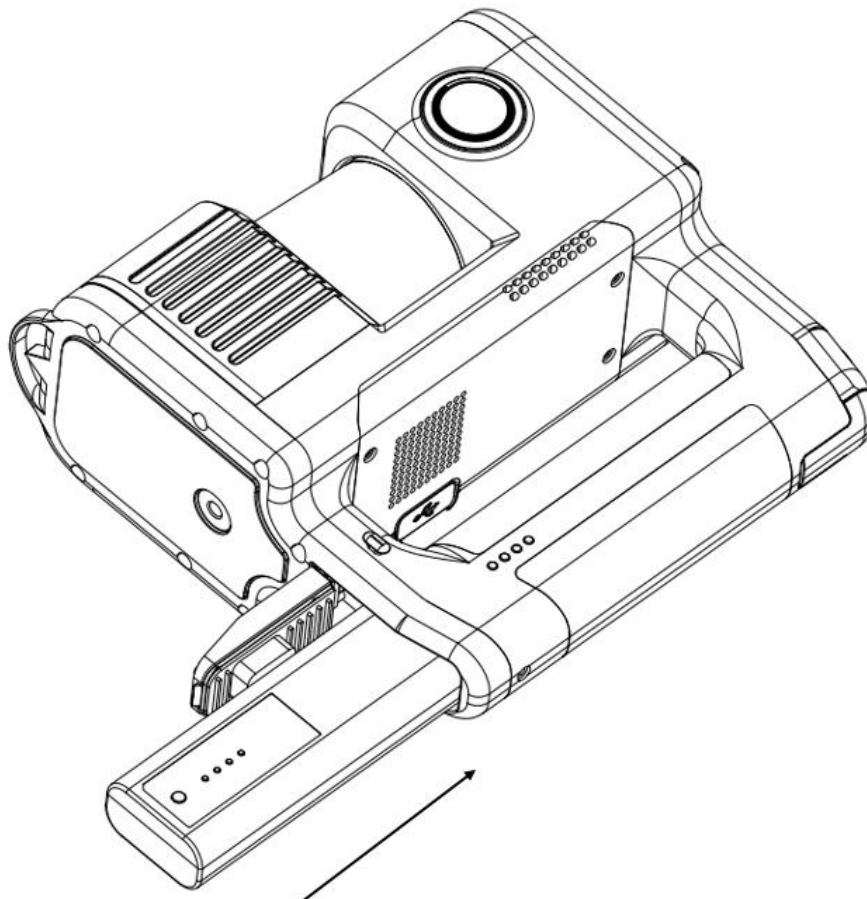

- 1、 Follow the instructions in the image above, insert the battery slowly with one side facing upward.
- 2、 Push the battery into the bottom of the device along the guide slots until it is fully inserted.
- 3、 To remove the battery, press the button firmly in the direction indicated by the arrow in the figure below. The battery will pop out; catch it by hand to prevent it from falling.

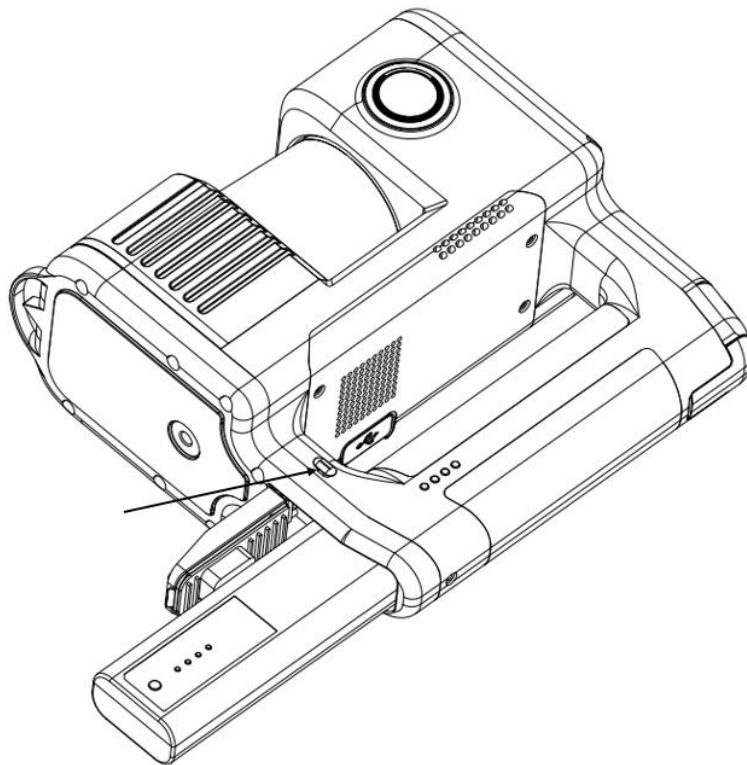

2、 Battery Charging and Indicator Lights

Use the standard charger and charging cable to connect to the Type-C port on the battery manager. Insert the battery into the battery manager to start charging. The charging time from 0 to 100% battery level is approximately 90 minutes. The recommended ambient temperature for charging is 5°C to 30°C.

3、 Description of the battery indicator light during charging:

Light 1224

Light 1224

LED Pattern	Battery Level
●○○○	0-25%
●●○○	26%-50%
●●●○	51%-75%
●●●●	76%-99%
●●●●	100%

● solid ● flashing ○ off

4、Indicator light description of the battery in non-charging status:

LED Pattern	Battery Level
○○○○	0-9%
●○○○	10-25%
●●○○	26%-50%
●●●○	51%-75%
●●●●	76%-100%

● solid ○ off

5、Battery Maintenance Instructions

1. After daily use of the device, the battery should be fully charged in a timely manner.
2. For fully charged batteries that are not used for a long time, recharge them once every 3 months.
3. For batteries with extremely low power or completely depleted power, they must be charged within 3 days.

Damage to the battery caused by failure to follow the above requirements is irreparable and not covered by the warranty.

Please perform timely maintenance to ensure the battery remains in good condition!

2.2、PDA Installation

As shown in the figure below, insert the phone holder downward into the cold shoe slot on the back cover of the device in the direction indicated by the arrow.

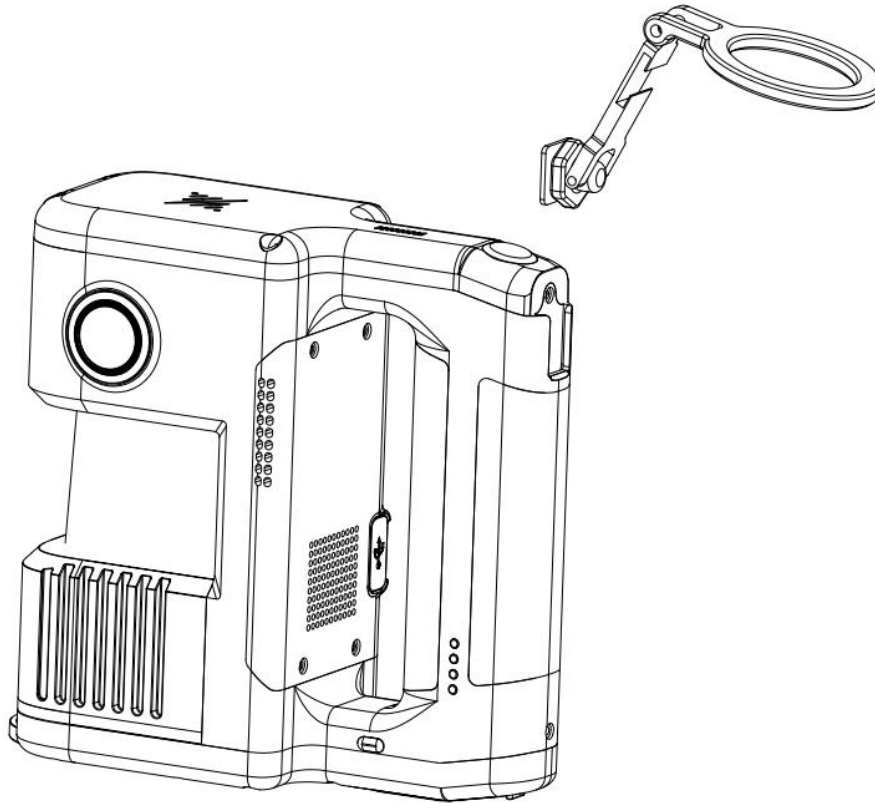

Attach the phone holder to the cold shoe mount of the device. The back of the PDA is equipped with a magnetic ring, which can mate with the magnetic ring on the phone holder to secure the PDA in place.

2.3: Description of Buttons and Indicator Lights

1、 Device Buttons

As indicated by the arrow in the figure below, this is the only button on the device, which controls functions such as power on, power off, scanning, and USB disk mode.

Light 1224

Light 1224

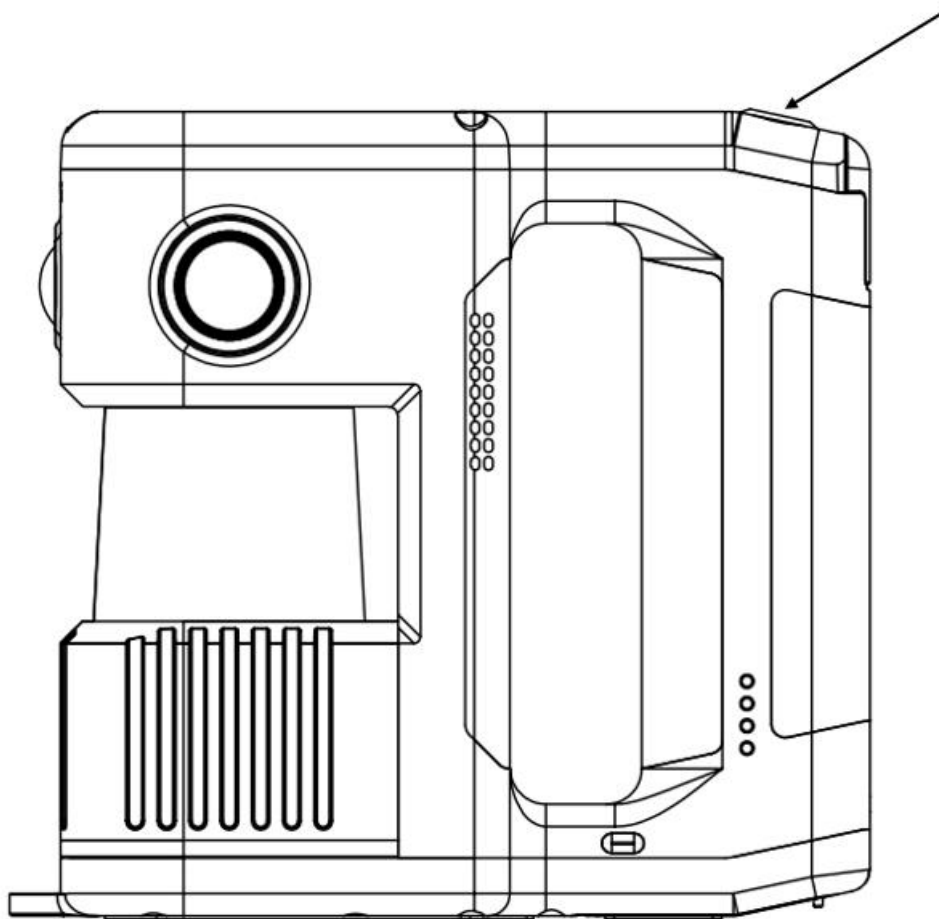

Functions	Button Operations	Device Status Description
Power On	Long press the battery button for 2 seconds	Long press the battery button for 2 seconds. When the device indicator changes from slow flashing blue to steady green, the device enters standby mode.
Power Off	Long press the battery button for 2 seconds in standby mode	When the device is in standby mode, long press the battery button for 2 seconds. The indicator turns off, indicating that the shutdown is complete.
Start Scan	Double click the device button	When the device is in standby mode, double-click the device button. The device indicator changes from steady green to fast flashing green for about 20 seconds, then switches to slow flashing green, indicating that scanning has started successfully and the device has entered scan mode.

Stop Scan	Double click the device button	When the device is in scan mode, double-click the device button. The indicator changes from slow flashing green to steady green, indicating that scanning has stopped successfully and the device returns to standby mode.
Switch to USB Disk Mode	Single click the device button + device indicator lights up white + single click the device button	When the device is in standby mode, single-click the device button, and the indicator will turn white for approximately 3 seconds. Single-click the button again while the white light is on to switch to USB disk mode. If no further operation is performed within 3 seconds, the device will remain in standby mode. When the device is in USB disk mode, single-click the device button, and the indicator will turn white for approximately 3 seconds. Single-click the button again while the white light is on to switch to standby mode. If no further operation is performed within 3 seconds, the device will remain in USB disk mode.

Notes

1. Before starting scanning, place the device on a flat and stable surface. After starting scanning, do not move the device for scanning until the green light flashes slowly.
2. The device startup time is approximately 25 seconds, and the scanning startup time is about 20 seconds.
3. During the scanning stop process, if the indicator light flashes green rapidly, it means the device is saving the scanned files. Powering off at this time may result in file loss or incomplete saving.
4. After scanning stops, the green fast flashing may last for a relatively long time, depending on the size of the scanning area.

2、Device Indicator Description

LED Pattern	Status
Off	Device not started
Solid green	Standby mode
Fast green flash	Starting/stopping scan

Slow green flash	Scanning mode
Slow blue flash	Starting up
Solid blue	USB mode
Solid yellow	Device not activated
Solid white	Mode switching
Solid red	Critical error
Red-green alternating	Firmware update (The battery level needs to be above 50%)

2.4: Data Copying

When the device is in standby mode (green indicator steady on), connect it to a computer using the included USB 3.0 cable. After about 5 seconds, the device will automatically enter USB disk mode (currently only desktop computers and laptops support automatic entry into USB disk mode; mobile phones and tablets require switching via the APP or device button). Once the computer recognizes the device, data copying can be performed. After copying is complete, unplug the USB cable, and the device will automatically exit USB disk mode and return to standby status.

Notes

1. USB disk mode will be disabled automatically after the device restarts.
2. After enabling USB disk mode, if the device is not powered off or disconnected, you must manually disable USB disk mode to continue scanning operations.
3. Please use the included USB 3.0 cable. Using other cables may result in slower copying speeds, or only work when inserted in one direction and fail when reversed.

2.5: Firmware Upgrade

The device firmware can be upgraded according to the prompts in the APP. There are two types of firmware upgrades: full package upgrade and small package upgrade. A small package upgrade can be performed directly on the device via the APP. If the APP prompts for a full package upgrade, follow the steps below:

1. Download the required full package firmware from the official website (usually larger than 1GB).
2. Switch the device to USB disk mode, and copy the firmware to the root directory

of the device storage.

3. Power off the device and restart it. The device will automatically enter firmware upgrade mode after rebooting.

≡: Maintenance and Care

4.1、Storage

4.2、Safety and Precautions

1. Prevent Drops and Impacts: This device is precision equipment. Dropping or subjecting it to external impacts may cause damage, resulting in abnormal operation or accuracy deviation.
2. Operating Environment and Cleaning: Do not use the device in dusty environments or rainy conditions. For cleaning, it is recommended to use a soft dry cloth or the included cleaning cloth to keep the radar window and lens surface clean. Do not touch the lens directly with your hands.
3. Initialization: Support the device with a tripod and place it on a flat, stable surface to complete initialization. Avoid performing initialization on uneven ground, as this may cause initialization failure or increased mapping thickness.
4. Temperature Safety: The device generates heat during operation. Avoid direct contact with the main body to prevent burns.
5. Heat Dissipation Protection: Do not cover or block the heat dissipation area during use. Obstructed heat dissipation will reduce cooling efficiency and may cause the device to stop operating automatically in severe cases.

Appendix:

Model	Lixel Holo 1		Remarks
Overall	Power	≤22W	

Performance	Weight	About 1.6Kg	
	Dimensions	192mm*87mm*181mm	
	Data Interface	USB 3.0	
	Internal Storage	EMMC 512G	
	RTK Module	Supported	
	WiFi	2.400 GHz ~ 2.4835 GHz 5.15 GHz ~ 5.850 GHz	
	Bluetooth	BT5.2	
	Operating Ambient Temperature	-20°C~50°C (No solar radiation)	
	Power Supply Method	Plug-in / Removable Battery	
	Working Duration	120min	
	Battery Capacity	48.24Wh	
	Charging Time (Room temperature: 25 degrees Celsius)	0%~100% about 100min	
	Charging Manager	Supported	
	Recommended charging ambient temperature	5°C~30°C	
Number of batteries supported by the charging	3 (Not simultaneously)		

	manager		
	Number of Cameras	3 (Fisheye*2, Front View*1)	
	Output Format	Point Cloud Format .las Image Format .Jpg	
Real-time Accuracy	Absolute Accuracy (Elevation)(RMS E)	3cm	Control point / RTK disconnection < 100m
	Absolute Accuracy (Horizontal)(RMS E)	3cm	Control point / RTK signal loss < 100 meters
	Relative Accuracy(RMSE)	1cm	The distance between two points is less than 10m.
	Repeatability Accuracy(RMSE)	2cm	For the same scene and same route: two scans with RTK
	Point Cloud Thickness	1cm	Point cloud plane thickness within 10m of the walking path
	Levelness (RTK / Control Point Fusion)	0.015°	RTK: Continuous connection within 100m; Control points: Interval between control points

			< 100m
	Dynamic Object Removal	Supported	
	Loop Closure Detection	Supported	
Post-processing Accuracy	Absolute Accuracy (Elevation)(RMS E)	3cm	Control point / RTK disconnection < 100m
	Absolute Accuracy (Horizontal)(RMS E)	3cm	Control point / RTK disconnection < 100 m
	Relative Accuracy(RMSE)	4mm	Distance between two points < 10 m
	Repeatability Accuracy(RMSE)	1cm	For the same scene and same route: two scans with RTK enabled
	Point Cloud Thickness	3mm	Point cloud plane thickness within 10m of the walking path
	Levelness (RTK / Control Point Fusion)	0.015°	
	Point Cloud Enhancement	Supported	Maximum enhanced point cloud density: 1 mm

	Dynamic Object Removal	Supported	
	Loop Closure Detection	Supported	
Laser Module	Laser Class	Class 1 / 905nm	
	Scanning Distance	0.1m~70m@10%, 95m@90%	
	Field of View	Azimuth360° (Occlusion90°) * Pitch60°	
	Point Cloud Frequency	200,000 points per second	
RTK Module	Supported Frequency Bands	Support	
	Accuracy	Plane: 0.8 cm + 1 ppm Elevation: 1.5 cm + 1 ppm	
Vision Module	Fisheye Camera FOV	200°*200°	
	Front Camera FOV	100°*85°	
	All Camera Resolutions	4000*3000	
	CMOS Size	1/2"	
	Camera Shutter	Rolling shutter	
Accessories	Packing box	Standard configuration	
	PDA	Standard equipment	

	Measuring rod	Optional	
	Ergonomic Backpack	Optional	

Hereby, XGRIDS declares that the radio equipment type Lixel Holo 1 is in compliance with Directive 2014/53/EU. The full text of the EU declaration of conformity is available at the following internet address: <https://www.xgrids.cn/>

This device complies with part 15 of the FCC Rules. Operation is subject to the following two conditions: (1) This device may not cause harmful interference, and (2) this device must accept any interference received, including interference that may cause undesired operation.

Any Changes or modifications not expressly approved by the party responsible for compliance could void the user's authority to operate the equipment.

Note: This equipment has been tested and found to comply with the limits for a Class B digital device, pursuant to part 15 of the FCC Rules. These limits are designed to provide reasonable protection against harmful interference in a residential installation. This equipment generates uses and can radiate radio frequency energy and, if not installed and used in accordance with the instructions, may cause harmful interference to radio communications. However, there is no guarantee that interference will not occur in a particular installation. If this equipment does cause harmful interference to radio or television reception, which can be determined by turning the equipment off and on, the user is encouraged to try to correct the interference by one or more of the following measures:

- Reorient or relocate the receiving antenna.
- Increase the separation between the equipment and receiver.
- Connect the equipment into an outlet on a circuit different from that to which the receiver is connected.
- Consult the dealer or an experienced radio/TV technician for help.
- This equipment complies with FCC radiation exposure limits set forth for an uncontrolled environment. This equipment should be installed and operated with minimum distance 20cm between the radiator & your body.