

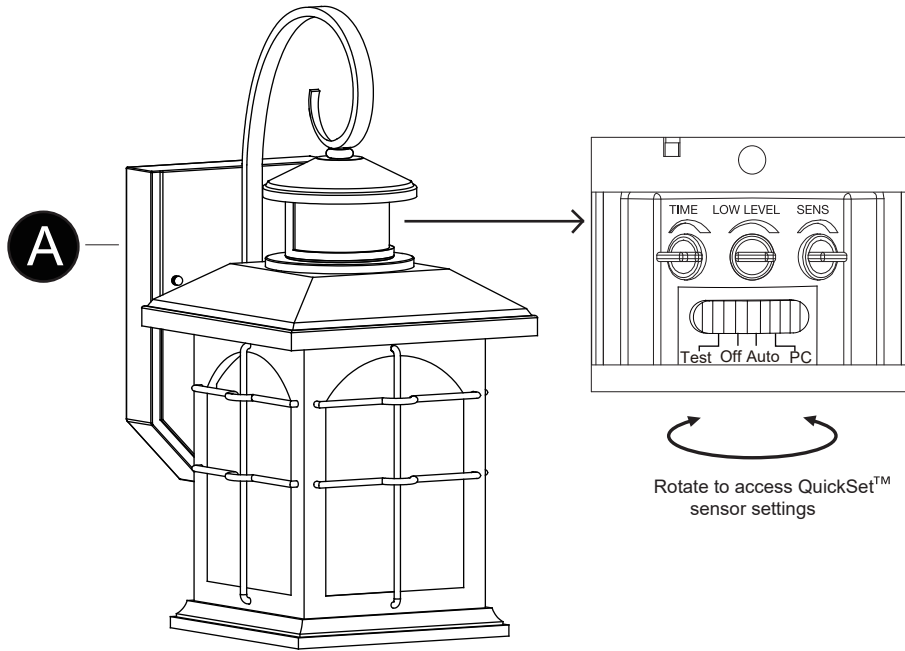

Questions, problems, missing parts?

Before returning to your retailer, call our customer service at 1-800-887-6326
 Monday – Friday 9:00 a.m. – 5:00 p.m. CST

PACKAGE CONTENTS



HARDWARE CONTENTS Note: Hardware not shown actual size.

AA		Cross Bar Unit X1	DD		Ball Nut X2
BB		Mounting Screw X2	EE		Rubber Pad X2
CC		Wire Connector X3			

⚠ SAFETY INFORMATION

Please read and understand this entire manual before attempting to assemble, operate or install the product.

WARNING

- Turn off electricity at main fuse box (or circuit breaker box) before beginning installation by removing fuse (or switching off circuit breaker).
- Be careful not to damage or cut the wire insulation (covering) during fixture installation. Do not permit wires to contact any surface having a sharp edge. To do so may damage or cut the wire insulation, which could cause serious injury or death from electric shock.

CAUTION

- All electrical connections must be in agreement with local codes, ordinances or the national electric code (NEC). Contact your municipal building department to learn about your local codes, permits and/or inspections.
- Risk of fire – most dwellings built before 1985 have supply wire rated for 140°F/60°C. Consult a qualified electrician before installation.
- Do not connect this fixture to an electrical system that does not provide a means for equipment grounding. Never use a fixture in a two-wire system that is not grounded. If you are not sure your lighting system has a grounding means, do not attempt to install this fixture. Contact a qualified, licensed electrician for information with regards to proper grounding methods as required by the local electrical code in your area.
- Only general ON/OFF wall switch applies for this fixture, the dimmable wall switch shouldn't be required.

Work Temperature: -22°F~104°F

PREPARATION

Before beginning assembly, installation or operation of product, make sure all parts are present. Compare parts with package contents list and diagram on previous page. If any part is missing or damaged, do not attempt to assemble, install or operate the product. Contact customer service for replacement parts.

Tools Required for Assembly (not included): Screwdriver, Phillips Screwdriver, Pliers, Electrical Tape, Wire Cutters, Safety Glasses, Ladder, Wire Stripper.

ASSEMBLY INSTRUCTIONS

Important to know

1. This fixture requires a 120 VAC, 60 Hz power source.
2. Make sure the power is switched OFF before installation.
3. Motion sensor: turns light ON automatically when motion is detected and turns light OFF automatically when motion stops.
4. Photocell keeps the light OFF during the daytime.
5. Compatible with most LED dimmable bulb.
6. Dimmable bulb required .

Installation Steps

Turn off the power at fuse or circuit box.

1. Unscrew the two ball nuts (DD). Remove the two rubber pads (EE) and the cross bar unit (AA) from the backplate (A).

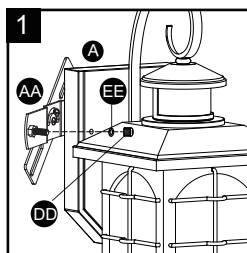

2. Attach the cross bar unit (AA) to the outlet box using two mounting screws (BB). Adjust the length of the preinstalled headless screws if necessary.

Note: Make sure that the headless screws are lined up horizontally to make the fixture level.

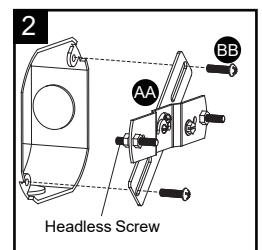

ASSEMBLY INSTRUCTIONS (continued)

3. Pull out the source wires from the outlet box. Make wire connections using wire connectors (CC) as follows:

- Connect the hot wire (usually black insulation) from the fixture to the black wire from the power source.
- Connect the neutral wire (usually white insulation) from the fixture to the white wire from the power source.
- Attach the fixture grounding wire (usually green insulation or bare wire) to the cross bar unit (AA) with the green grounding screw, then connect it to the house grounding wire with the wire connector (CC).

Carefully put all of the wires back into the outlet box.

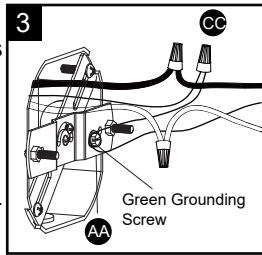

4. Attach the backplate (A) of the fixture to the cross bar unit (AA) by aligning and inserting the two headless screws from the cross bar unit (AA) into the open holes on the backplate (A), then place the two rubber pads (EE) over the exposed headless screws before screwing the two ball nuts (DD).

Note: With silicone caulking compound, caulk completely around where the backplate meets with the wall surface to prevent water from seeping into the outlet box.

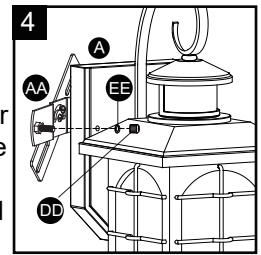

5. Install a bulb (not included). See relamping label at socket area or packaging for maximum wattage allowed.

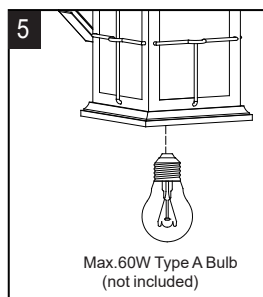

Turn on the power at fuse or circuit box

The Position of Control Panel

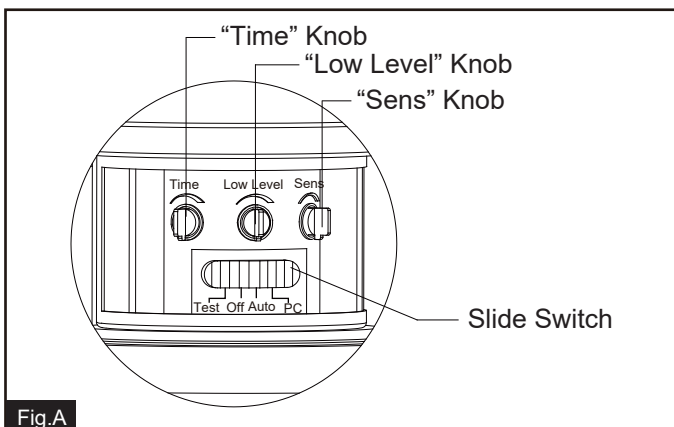
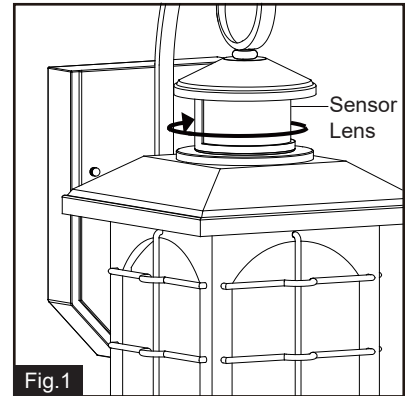
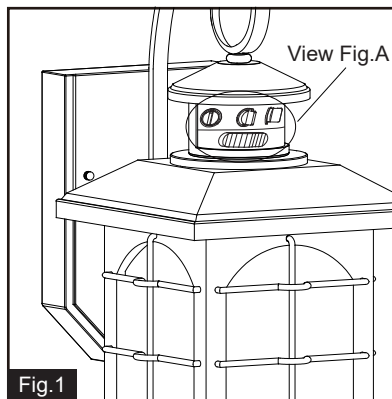
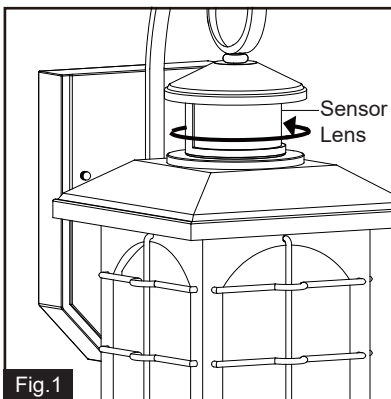

Step 1: Rotate the sensor lens from left side to right side to show the adjustable knobs and slide switch. (See Fig.1)

Step 2: Adjust time, low level brightness and sensitivity by knobs and choose the mode you want by slide switch. (See Fig.2 and Fig A).

Step 3: Restore the sensor lens to original position. (See Fig.3)

FUNCTION AND OPERATION

Choose a mode by sliding the slide switch. The light will turn on immediately when power is applied. Wait for 30 seconds to allow the sensor to warm up.

1. Test MODE (daytime and nighttime operation.)
 - The light will turn to low-level brightness (0~50%). The light will turn to high-level brightness (full brightness) when motion is detected, and stay on as long as the motion continues. The light will turn to the low-level brightness you set after 5 seconds when motion is no longer detected.
2. Off MODE (nighttime operation only)
 - At dusk, the light stays off and will turn to high-level brightness (full brightness) when motion is detected, and stay on as long as the motion continues. When the motion stops, the light will stay on for the predetermined time set (5 ~ 180 seconds), then the light will turn off automatically.
3. Auto MODE (nighttime operation only)
 - At dusk, the light will turn to low-level brightness (0~50%). The light will turn to high-level brightness (full brightness) when motion is detected, and stay on as long as the motion continues. When the motion stops, the light will remain on for the predetermined time set (5~180 seconds), and then turn to the low-level brightness you set.
 - The light will turn off automatically at dawn.
4. PC MODE (nighttime operation only)
 - The light will turn on (full brightness) automatically at dusk and turn off automatically at dawn.
5. Manual Override MODE (nighttime operation only)
 - To shift to the manual override mode, set the switch to "Off" or "Auto" mode. Turn the wall switch "OFF" and then turn it "ON" within 3 seconds. The light will stay on through all night. To restore to the "Off" or "Auto" mode, turn the wall switch "OFF" and then turn it "ON" within 3 seconds again. (See Fig.4)
 - The light will last for one night only and turn off automatically at dawn.

- Note: 1. The low level brightness can be adjusted from 0 to 50% by rotating "Low level" knob. (See Fig.5)
2. Always keep the wall switch in the "ON" position (including the daytime).
3. Please notice the warm up time is 30 seconds, any operations are invalid during this time.

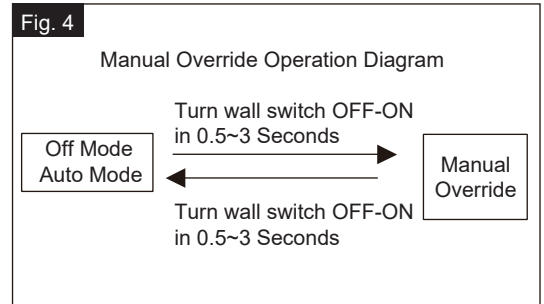

Customization Options

Shut-off Delay

1. The Shut-off delay is the length of time that the light will stay in high-level brightness after motion stops.
2. The Shut-off delay can be adjusted by using the "Time" knob when the slide switch is set in "Off" or "Auto" mode.
3. The range of shut-off delay is 5 seconds to 3 minutes.
4. Rotate the knob clockwise for increasing the shut-off delay.
5. Rotate the knob counterclockwise for decreasing the shut-off delay.

Sensitivity of Motion Sensor

1. The sensitivity can be adjusted from 5 to 40 feet by using the "Sens" knob. (See Fig.5).
2. Turn the knob clockwise for increase sensitivity.
3. Turn the knob counterclockwise for decrease sensitivity.

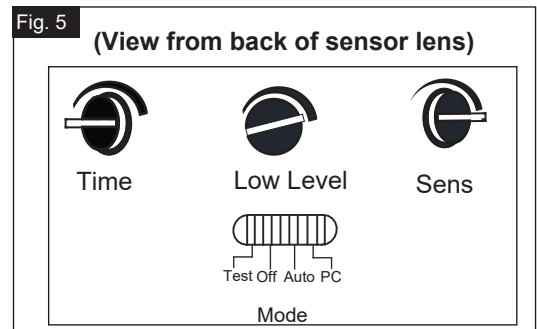

NOTE:

1. The sensitivity of the motion sensor will increase as the environmental temperature gets colder. For best performance, gently clean the lens with a soft cloth every 1 or 2 months to ensure maximum sensitivity.
2. The magnitude of adjustment for sensitivity and time may not be precisely proportionate to the amount when the knob is turned. (See Fig.5)
3. When installed at a height of 6.5 feet, at 77 degrees Fahrenheit, the light will provide a maximum detection distance of 40 feet and detection range of 180 degrees. (See Fig.6 Fig.7)
4. The sensor will be more sensitive to motion across its detection path than motion directly towards it. (See Fig.8)
5. To reduce possible nuisances, do not mount the fixture near a heat source like an air conditioner, vent or furnace exhaust, or in a direction facing any reflecting object or other light source.

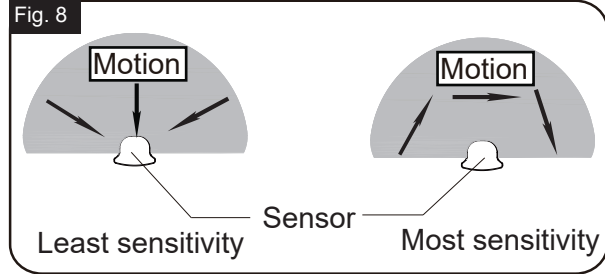
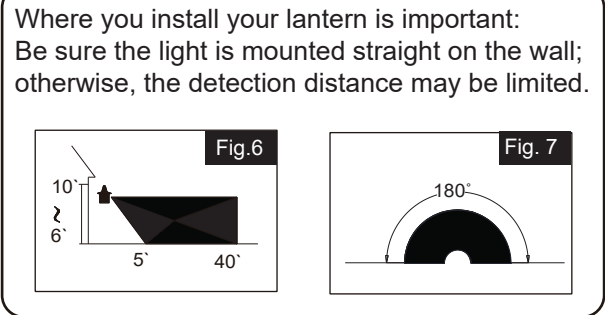

The following parts are available for reorder if damaged or missing. Call our toll free at 1-800-887-6326.

Spare Parts List:

AA 	BB 	CC 	Assembly Kit 4857MM (1 SET)
DD 	EE 		

CARE AND MAINTENANCE

- To clean, turn off and wipe with a damp, non-abrasive cloth.

TROUBLESHOOTING

Refer to following information to solve your problems.

SYMPTOM	DAY/NIGHT	POSSIBLE CAUSE	SOLUTION
If the light isn't on	Day	Slide switch is not set in the test mode.	Set the slide switch in the test mode for testing.
	Night	Wall switch or circuit breaker is off.	Turn on wall switch or circuit breaker.
		Light bulb may be burned out.	Test the light bulb on normal working light fixture.
		Light bulb is loose.	Tighten the light bulb.
		Incorrect or loose wire connections.	Check wire connections.
		Too much sunlight is shining onto sensor in the early evening.	Relocate fixture away from western facing wall.
Too much light is shining onto sensor due to another light source, such as a street lamp or other light fixture.	Eliminate or turn off other light source, block other light source from shining onto sensor, or relocate fixture.		



SYMPTOM	DAY/NIGHT	POSSIBLE CAUSE	SOLUTION
If the light stays on	Day	The fixture may be installed in shaded area.	Only need to relocate fixture.
		On cloudy or overcast days, the light may stay on longer than anticipated.	No corrective action needed.
	Night	Still on the manual override mode.	Turn off the light, then turn it on after 5 seconds.
		False triggering caused by a heat source, such as a heater, dryer vent, or heated swimming pool.	Eliminate heat source or relocate fixture.
		The switch is not set in any mode.	Slide it again to the mode you want.
If the light is blinking	Night	The bulb is non-dimmable or the quality of light bulb is not good.	Use another normal incandescent lamp to confirm if the light function is normal, otherwise change the bulb.
		Passing cars and reflective objects interfere with the sensor.	Relocate fixture.
The light comes on for no apparent reason	Night	Street or sidewalk traffic is triggering motion sensor.	Adjust the "Sens" knob to reduce the sensitivity.
		False triggering caused by a heat source, such as a heater, dryer vent, or heated swimming pool.	Eliminate heat source or relocate fixture.

If unable to fix any of the above issues, please consult a certified electrician.

FIVE-YEAR LIMITED WARRANTY: If, during normal use, this PATRIOT LIGHTING® lighting fixture breaks or fails due to a defect in material workmanship within five (5) years from the date of original purchase, simply bring this lighting fixture with the original sales receipt back to your nearest MENARDS® retail store. At its discretion, PATRIOT LIGHTING® agrees to have the product or any defective part(s) repaired or replaced with the same or similar PATRIOT LIGHTING® product or part free of charge, within the stated warranty period, when returned by the original purchaser with original sales receipt. This warranty; (1) excludes expendable parts including but not limited to light bulbs; (2) does not cover damage that has resulted from abuse or misuse; and (3) does not cover any losses, labor, injuries to persons/property or costs. This warranty does give you specific legal rights and you may have other rights, which vary from state to state.



Questions, problems, missing parts?

Before returning to your retailer, call our customer service at 1-800-887-6326
Monday – Friday 9:00 a.m. – 5:00 p.m. CST

