

DE'LONGHI

COOKING

**INSTALLATION and SERVICE INSTRUCTIONS
USE and CARE INSTRUCTIONS**

**DEIND603
DEIND604
DEIND804
INDUCTION BUILT-IN COOKTOPS**

distributed by
**DeLonghi Australia Pty Ltd
DeLonghi New Zealand Ltd**



Dear Customer,

Thank you for having purchased and given your preference to our product.

The safety precautions and recommendations reported below are for your own safety and that of others. They will also provide a means by which to make full use of the features offered by your appliance.

Please keep this booklet in a safe place. It may be useful in future, either to yourself or to others in the event that doubts should arise relating to its operation.

This appliance must be used only for the task it has explicitly been designed for, that is for cooking foodstuffs. Any other form of usage is to be considered as inappropriate and therefore dangerous.

The manufacturer declines all responsibility in the event of damage caused by improper, incorrect or illogical use of the appliance or by faulty installation.

Important:

This appliance is designed and manufactured solely for the cooking of domestic (household) food and is not suitable for any non domestic application and therefore should not be used in a commercial environment.

The appliance guarantee will be void if the appliance is used within a non domestic environment i.e. a semi commercial, commercial or communal environment.

This appliance has been designed and constructed in accordance with the following codes and specifications:

- AS/NZS 60335.1 General Requirements for Domestic electrical appliances
- AS/NZS 60335.2.6 Particular Requirements for Domestic electrical cooking appliances
- AS/NZS CISPR 14.1 Electromagnetic Compatibility Requirements.

PRODUCT LABEL



IMPORTANT PRECAUTIONS AND RECOMMENDATIONS FOR USE OF ELECTRICAL APPLIANCES

Use of any electrical appliance implies the necessity to follow a series of fundamental rules. In particular:

- Never touch the appliance with wet hands or feet.
- Do not operate the appliance barefooted.
- The appliance is not intended for use by young children or infirm persons without supervision.
- Young children should be supervised to ensure they do not play with the appliance.

The manufacturer cannot be held responsible for any damages caused by improper, incorrect or illogical use of the appliance.

IMPORTANT PRECAUTIONS AND RECOMMENDATIONS

After having unpacked the appliance, check to ensure that it is not damaged.

In case of doubt, do not use it and consult your supplier or a professionally qualified technician.

Packing elements (i.e. plastic bags, polystyrene foam, nails, packing straps, etc.) should not be left around within easy reach of children, as these may cause serious injuries.

- Read the instructions carefully before installing and using the appliance.
- The appliance should be installed and all the electrical connections made by a qualified engineer in compliance with local regulations in force and following the manufacturer's instructions.
- Do not attempt to modify the technical characteristics of the appliance as this may become dangerous to use.
- Do not carry out cleaning or maintenance operations on the appliance without having previously disconnected it from the electric power supply.
- After use, ensure that the controls are switched off.
- Keep children away from the appliance when it is in use.

- **WARNING:** Accessible parts will become hot when in use. To avoid burns and scalds, young children should be kept away.
- Young children should be supervised to ensure that they do not play with the appliance.
- Children, or persons with a disability which limits their ability to use the appliance, should have a responsible person to instruct them in its use. The instructor should be satisfied that they can use the appliance without danger to themselves or their surroundings.
- During and after use of the appliance, certain parts will become hot. Do not touch hot parts.
- Make sure that electrical cables connecting other appliances in the proximity of the cooktop cannot come into contact with the hob.
- Do not allow heavy or sharp objects to drop on the glass ceramic hob. If the hob is cracked or otherwise damaged by falling objects etc., disconnect the electrical power cord and call Customer Service.
- Do not scratch the hob with sharp objects. Don't use the hob as a work surface.
- **WARNING:** When correctly installed, your product meets all safety requirements laid down for this type of product category. However special care should be taken around the underneath of the appliance as this area is not designed or intended to be touched and may contain sharp or rough edges, that may cause injury.
- **Fire risk!** Do not store flammable material on the hob top.
- The manufacturer declines all liability for injury to persons or damage to property caused by incorrect or improper use of the appliance.
- **IMPORTANT NOTE: This appliance shall not be used as a space heater, especially if installed in marine craft or caravans.**
- **Do not operate your appliance by means of an external timer or separate remote-control system.**
- **This appliance is for domestic use only.**
- **If the supply cord (not supplied with the appliance) is damaged, it must be replaced by the manufacturer or its service agent or a similarly qualified person in order to avoid a hazard.**

OTHER IMPORTANT PRECAUTIONS AND RECOMMENDATIONS

- Do not place or leave empty pans on the glass ceramic hob.
- Metallic objects such as knives, forks, spoons and lids should not be placed on the hob surface since they can get hot.
- Do not use metallic kitchen utensils (e.g. ladles). It is preferable to use plastic or wood kitchen utensils.
- Please use pans of recommended size (see minimum pan diameter recommended). It is not advisable to use pans smaller than the cooking zone. The pans have to be placed in the centre of the cooking zone.
- Do not use defective pans or pans with a curved bottom.
- Please use suitable pans marked for induction cooking.
- Please keep your distance from the electromagnetic fields by standing 5-10 cm from the cooking zones. When possible use the rear cooking zones.
- Magnetic objects (e.g. credit cards, floppy disks, memory cards) and electronic instruments (e.g. computers, MP3 players) should not be placed near the appliance, as they may be affected by its electromagnetic field.
- The heating of magnetic tins is forbidden! Close tins may explode by exceeding pressure while heating. There is a burning risk with open tins as well, because the integrated temperature protection can't work well.
- **HEALTH HAZARD! This appliance complies with electromagnetic safety standards. However, persons with cardiac pacemakers or other electrical implants (such as insulin pumps) must consult with their doctor or implant manufacturer before using this appliance to make sure that their implants will not be affected by the electromagnetic field. Failure to follow this advice may result in death.**

INSTALLATION

CAUTION:

- This appliance must be installed in accordance with these installation instructions.
- This appliance shall only be serviced by authorised personnel.
- This appliance is to be installed only by an authorised person in compliance with the current electrical regulations and in observation of the instructions supplied by the manufacturer.
Failure to comply with this condition will render the guarantee invalid.
- Incorrect installation, for which the manufacturer accepts no responsibility, may cause personal injury or damage.
- Always disconnect the appliance from mains power supply before carrying out any maintenance operations or repairs.

FITTING REQUIREMENTS

This cooktop can be built into a working surface 30 to 40 mm thick and 600 mm deep. In order to install the ceramic hob into the kitchen fixture, a hole with the dimensions shown in figure 1 has to be made, keeping in consideration the following:

- The cooktop shall not be installed directly above a dishwasher, fridge, freezer, washing machine or clothes dryer, as the humidity may damage the cooktop electronics.
- If the cooktop is installed above an oven, the oven shall be provided with cooling fan. The two appliances should be connected to the electrical supply with independent connections.
- **IMPORTANT WARNING! This cooktop requires adequate supply of fresh, cool air to fully function. The base of the cooktop must have direct unrestricted ventilation to the room where the cooktop is installed. Follow the requirements of figure 3 or 4.**
- There must be a distance of at least 650 mm between the hob and any wall cupboard or extractor hood positioned immediately above (see fig. 2).
- We would point out that the adhesive which bonds the plastic laminate to the furniture must withstand temperatures not less than 150° C to avoid delamination.
- The walls of the units must be capable of resisting temperatures of 75 °C above room temperature.
- Do not seal the cooktop into the benchtop with silicone or glue; this makes future servicing difficult. Delonghi will not cover the costs of removing the cooktop, or of damage caused by this removal.
- The walls surrounding the cooktop must be made of heat-resistant material.
- Do not install the appliance near inflammable materials (eg. curtains).

WARNING

When correctly installed, your product meets all safety requirements laid down for this type of product category. However special care should be taken around the underneath of the appliance as this area is not designed or intended to be touched and may contain sharp or rough edges, that may cause injury.

Figure 1

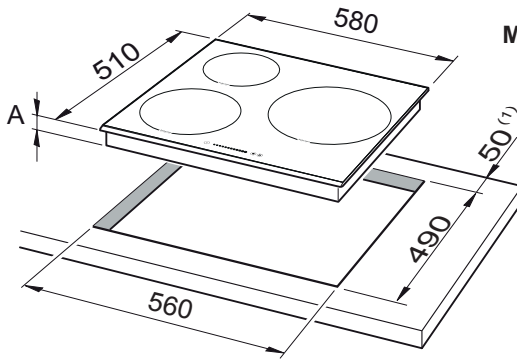

Mod. DEIND603

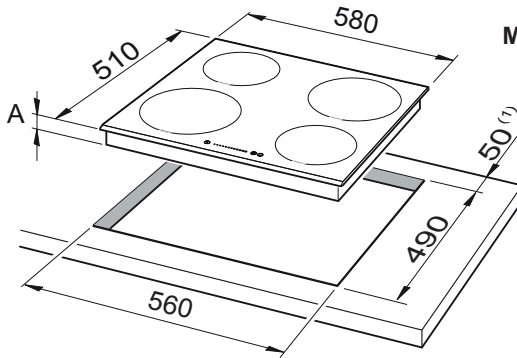

Mod. DEIND604

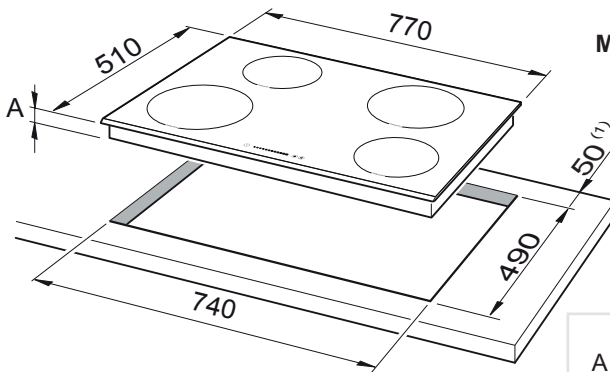

Mod. DEIND804

A	58 mm	from the top of countertop to bottom of cooktop
---	-------	---

(1) at least 50 mm between the back side of the cut-out and the back of the countertop.

Figure 2

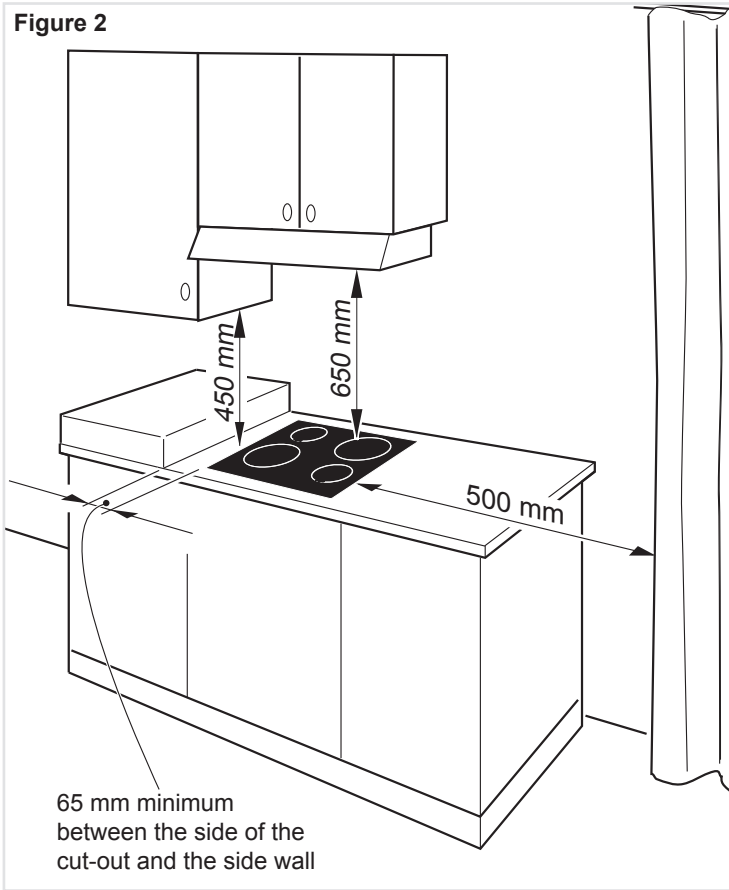
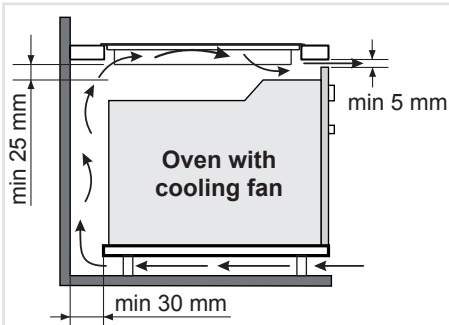
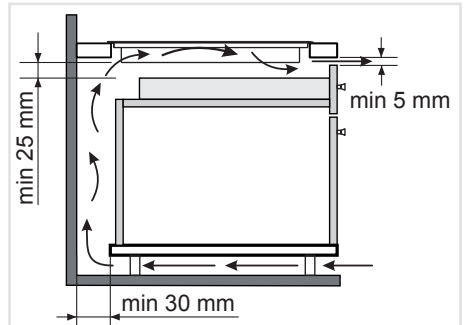

Figure 3



Minimum clearances and
ventilation requirements
(oven installed below)

Figure 4



Minimum clearances and
ventilation requirements
(cupboard or drawer space below)

FASTENING THE COOKTOP

Each cooktop is provided with an installation kit including brackets and screws for fastening the cooktop to benches from 30 to 40 mm thick.

The kit includes four “F” brackets and four self-threading screws “S” (fig. 6).

- Cut the unit according to the dimensions in fig. 1.
- Turn the hob upside down and rest the glass side on a soft surface.
- Spread the seal “G” around the edge of the hob (fig. 5).
- Fasten the brackets “F” to the appropriate socket holes, without tightening the screws “S” for the moment. Make sure that the tabs are mounted correctly, as shown. Rotate the tabs so that the cooktop can be put into the cutout.
- Put the cooktop into the cutout and position it correctly.
- Put the brackets “F” into place; tooth “A” of the brackets should go into the hole (fig. 6).
- Tighten screws “S” until the cooktop is completely secured to the bench.
- Using a sharp cutter or trimmer knife, trim the excess sealing material around the edge of the cooktop. Take care not to damage the workbench.

Figure 5

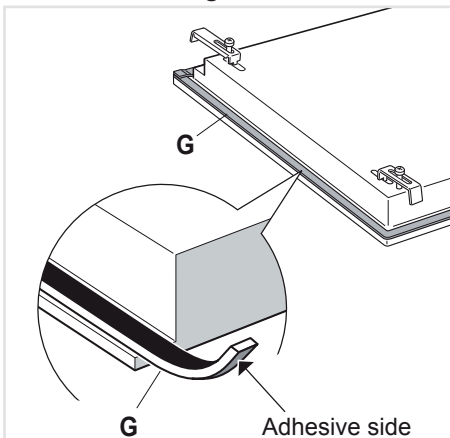
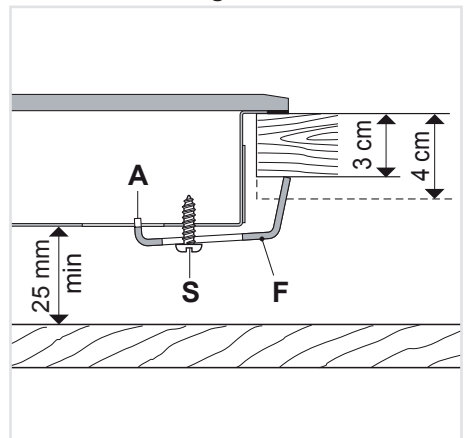

Figure 6



ELECTRICAL REQUIREMENTS

- The appliance must be connected to the mains checking that the voltage corresponds to the value given in the rating plate and that the electrical cable sections can withstand the load specified on the plate.
- A suitable isolating switch providing full disconnection from the mains power supply shall be incorporated in the permanent wiring, mounted and positioned to comply with the local wiring rules and regulations. The isolating switch must be of an approved type and provide a 3 mm air gap contact separation in all poles (or in all active [phase] conductors if the local wiring rules allow for this variation of the requirements).
- The isolating switch shall be easily accessible to the customer with the cooktop installed.
- The power supply cable must not touch the hot parts and must be positioned so that it does not exceed 75°C above ambient.
- To connect the appliance to the mains electricity supply, do not use adapters, reducers or branching devices as they can cause overheating and burning.

N.B. The connection of the appliance to earth is mandatory.

If the installation requires alterations to the domestic electrical system call a qualified electrician. He should also check that the domestic electrical system is suitable for the power drawn by the appliance.

Replacing the power cord (not supplied with the appliance) must be done by a qualified electrician in accordance with the instructions supplied by the manufacturer and in compliance with established electrical regulations.

CONNECTION OF THE POWER SUPPLY CABLE

Important! This cooktop must be connected to the electricity supply only by an authorised person.

To connect the feeder cable to the hob it is necessary to carry out the following operations:

- Unhook the terminal board cover “A” by inserting a screwdriver into the two hooks “B” (fig. 7). Open completely the terminal block cover “A”.
- Unscrew the screw “C”, then unhook the cable clamp “D” by inserting a screwdriver into the hook “E”. Remove completely the cable clamp “D” (fig. 7).
- Connect the phase, neutral and earth wires to terminal board “F” according to the diagrams in fig. 8; the U bolts “G” (fig. 7) shall be used as indicated in the diagrams in fig. 8 (they are supplied already fitted to the terminals or inside the terminal board, behind the cover).
- Strain the feeder cable and block it with cable clamp “D” (by hooking hook “E” and screwing screw “C”).
- Close the cover “A” of the terminal board “F” (check the two hooks “B” are correctly hooked).

VOLTAGE AND POWER CONSUMPTION

Mod. DEIND603

220-240/380-415 V 3N~ 50/60 Hz 6700 W 29.13 A (diversity not applied)

Mod. DEIND604 - DEIND804

220-240/380-415 V 3N~ 50/60 Hz 7400 W 32.17 A (diversity not applied)

FEEDER CABLE SECTION

This hob must be connected to electrical supply using V105 insulated cable.

220-240 V ac	3 x 4 mm ² (*) (**)
380-415 V 2N ac	4 x 2.5 mm ² (*) (**)
380-415 V 3N ac	5 x 2.5 mm ² (*) (**)

(*) Connection with wall box connection

(**) Notes for models DEIND604, DEIND804 only:

- Diversity factor applied
- A diversity factor may be applied to the total loading of the appliance only by a suitably qualified person

If the supply cord (not supplied with the appliance) is damaged, it must be replaced by the manufacturer or its service agent or a similarly qualified person in order to avoid a hazard.

Figure 7

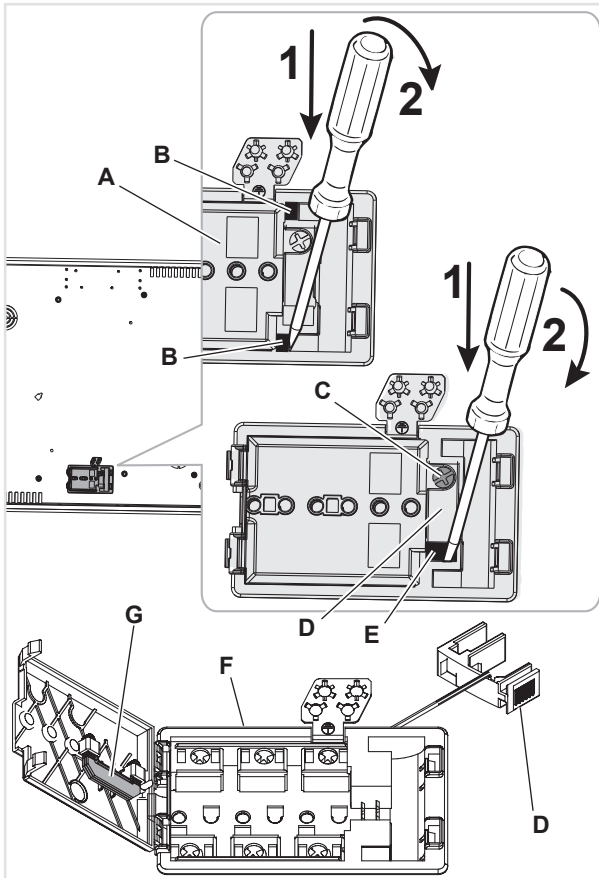
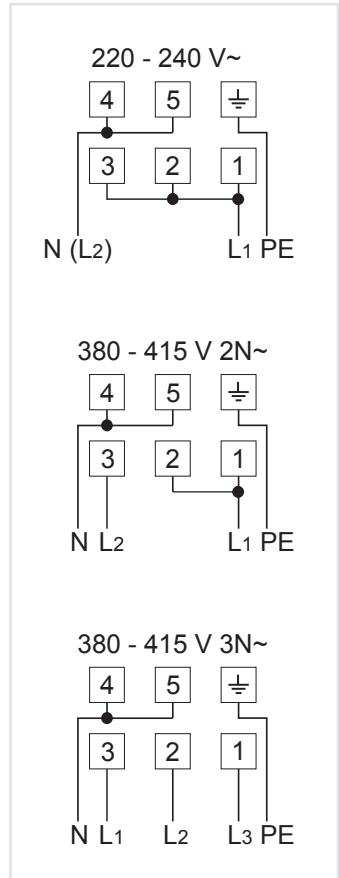

Figure 8



ELECTRIC DIAGRAMS

Figure 9

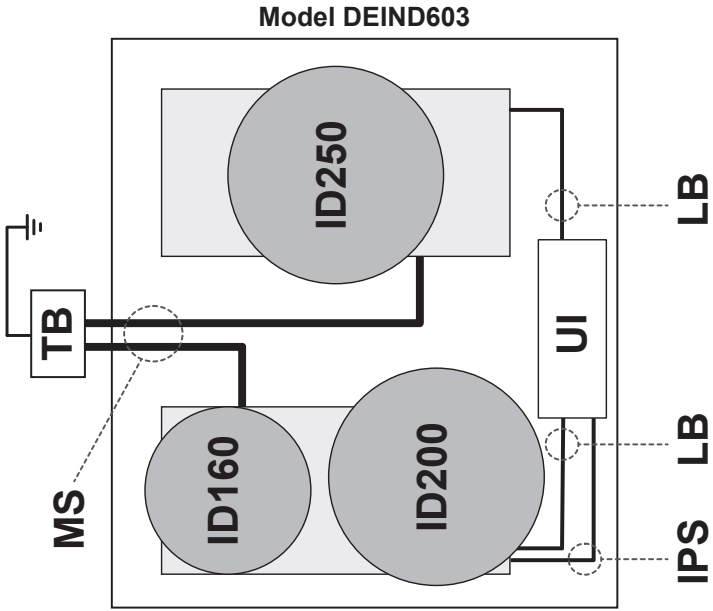
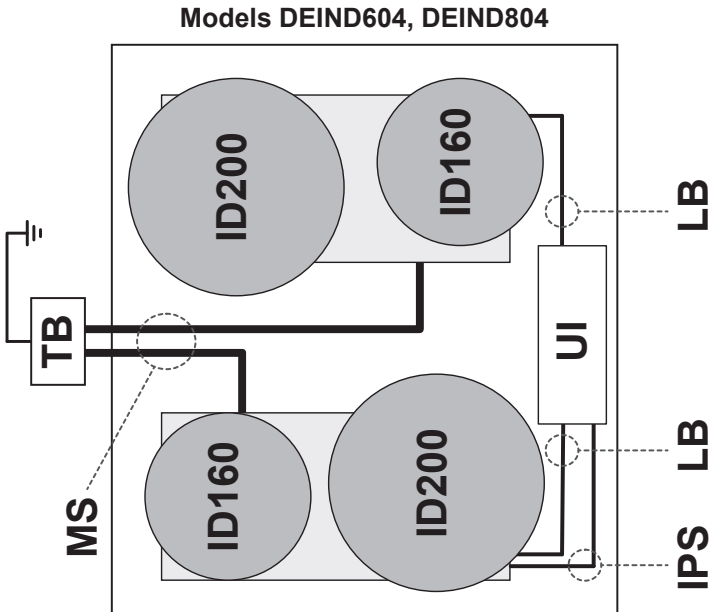

Figure 10



ELECTRIC DIAGRAM KEY

ID160	Induction zone, Ø 160 mm
ID200	Induction zone, Ø 200 mm
ID250	Induction zone, Ø 250 mm
UI	User interface
LB	Lin-Bus
IPS	Interface power supply
MS	Main supply (L, N)
TB	Terminal block

USE AND CARE

FEATURES AND TECHNICAL DATA

Mod. DEIND603

Figure 11

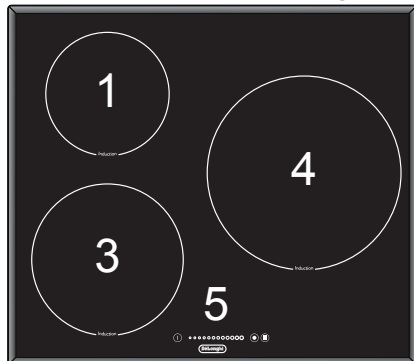

Mod. DEIND604

Figure 12

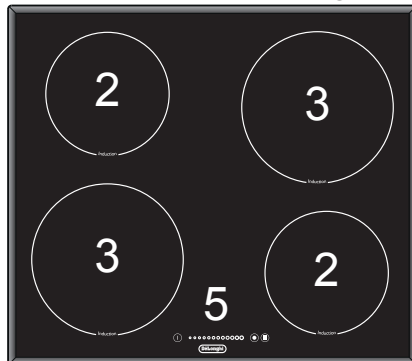

Mod. DEIND804

Figure 13

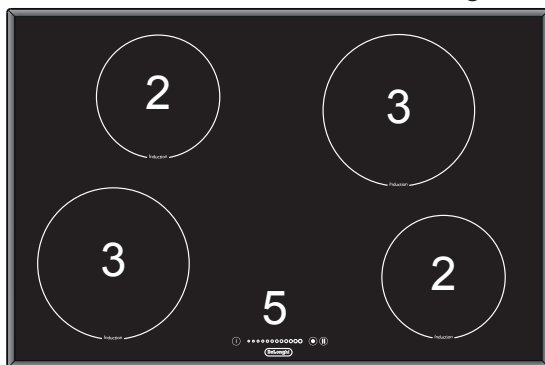

- | | | |
|---------------------------|----------|---|
| 1. Induction cooking zone | Ø 160 mm | Normal Power: 1200 W
Booster Power: 1400 W |
| 2. Induction cooking zone | Ø 160 mm | Normal Power: 1400 W |
| 3. Induction cooking zone | Ø 200 mm | Normal Power: 2300 W
Booster Power: 3000 W |
| 4. Induction cooking zone | Ø 250 mm | Normal Power: 2300 W
Booster Power: 3000 W |
| 5. Touch controls | | |

Note: The Nominal and Booster Power may change depending on the size and material of the pan set on the cooking zone.

Figure 14

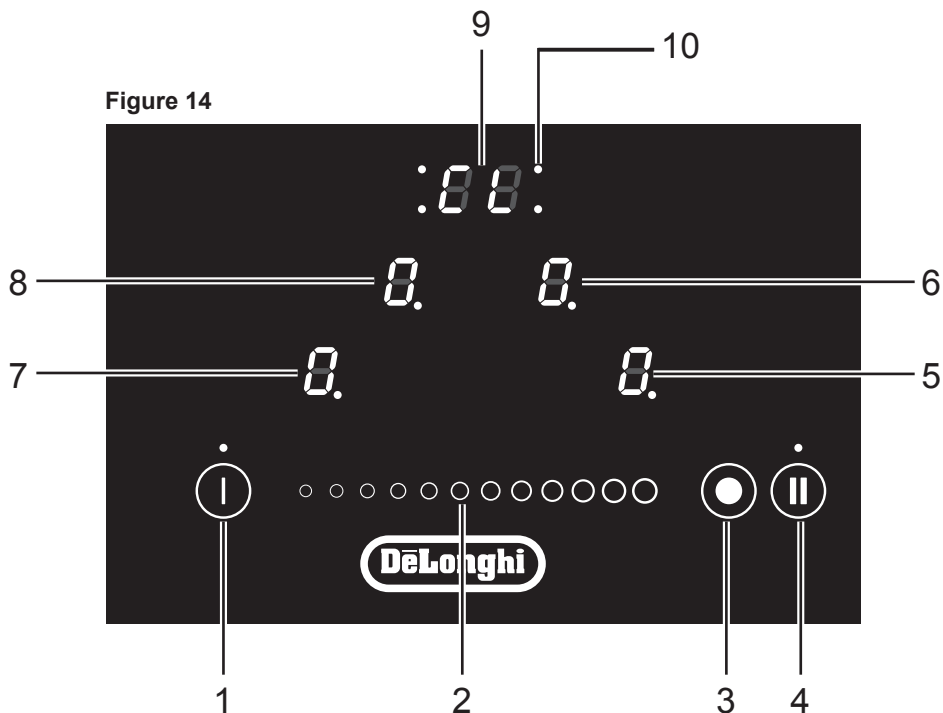

TOUCH CONTROLS

1. ON/OFF key
2. Setting selector
3. Booster function key (some zones only) and Child Lock selection key (to be set in combination with other keys, see chapter CHILD LOCK SAFETY)
4. Pause function key
5. Front right cooking zone display (for models DEIND604, DEIND804 only)
6. Rear right cooking zone display (or Central right zone display for model DEIND603 only)
7. Front left cooking zone display
8. Rear left cooking zone display
9. Automatic cooking timer key/display
10. Led indicating the programmed zone

Notes:

- Each selection (by touching one of the keys) is indicated by an acoustic signal (beep).
- The touch control area is switched off automatically (and a warning beep sounds for 10 seconds):
 - if one or more keys are touched for more than 10 seconds;
 - if an object is positioned on the touch control area;
 - in the case of spillage of liquids on the control keys.

Attention: Detach the appliance from the mains if the ceramic glass is cracked and contact the After-Sales Service. Metallic objects such as knives, forks, spoons and lids should not be placed on the hob surface since they can get hot.

HOW TO USE THE COOKING HOB

The ceramic hob is fitted with induction cooking zones. These zones, shown by painted disks on the ceramic surface, are controlled by a touch control system.

In the front central area of the hob, the displays of the touch control system indicate:



Figure 15



= Cooking zone Off (not activated)



= Cooking zone On (activated but not operating).

If all the zones are in zero setting, the touch control system switches off automatically (touch controls Off) after about 10 seconds.



= Power levels



= “Booster” function (available for some zones only)



= Remaining heat indicator



= Pan detection indicator



= Child Lock safety



= Automatic cooking timer

Note: Each lit figure (excluding the “Automatic cooking timer” display) refers to the relevant cooking zone.

INDUCTION COOKING SYSTEM

When your induction hob is switched On and a cooking zone has been selected, the electronic circuits produce induced currents that instantaneously heat the bottom of the pan which then transfers this heat to the food. Cooking takes place with hardly any energy loss between the induction hob and the food.

Your induction hob operates only if a correct pan with the right features is placed on a cooking zone. Please refer to **COOKWARE FOR INDUCTION COOKING**.

If the pan detection symbol  appears on the display, your pan is not suitable and your induction hob will not operate. After 10 minutes without detecting any pan, the cooking zone switches Off automatically.

REMAINING HEAT INDICATORS

When the temperature of a cooking zone is still hot, the relevant  remaining heat indicator lights up on the display to alert you of the hot surface.

Avoid touching the hob surface over the cooking area. Please pay special attention to children.

When the  is lit on the display, it is still possible to start cooking again; just operate the cooking zone as indicated in the chapter POWER IGNITION AND ADJUSTMENT OF A COOKING ZONE.

COOKWARE FOR INDUCTION COOKING

The induction cooking system OPERATES ONLY if using correct cookware suitable for induction cooking.

The bottom of the pan has to be ferromagnetic to generate the electromagnetic field necessary for the heating process (meaning a magnet has to stick to the bottom of the pan).

Pans made from the following materials are not suitable:

- glass, wood, porcelain, ceramic, stoneware;
- pure stainless steel, aluminium or copper without magnetic bottom.

To check if a pan is suitable or not:

- test the bottom of the pan with a magnet: if the magnet sticks, the pan is suitable.
- if a magnet is not available pour a small amount of water inside the pan and place the pan on a cooking zone. Switch on the cooking zone: if the symbol  (pan detection) appears on the cooking zone display (instead of the power level), the pan is not suitable.

Important note: the cooking zones will not operate if the pan diameter is too small ( pan detection symbol will appear on the cooking zone display). To correctly use the cooking zones follow the indications given in the following table.

Induction cooking zone	Minimum pan diameter recommended (referred to the bottom of the pan)
Cooking zone Ø 160 mm	110 mm
Cooking zone Ø 200 mm	145 mm
Cooking zone Ø 250 mm	180 mm

Pay attention: The pan shall always be centred over the middle of the cooking zone. It is possible to use oversized pans but the bottom of the pan cannot touch other cooking zones.

Always use pans with thick, completely flat bottom.

Do not use pans with concave or convex bottom; these could cause overheating of the cooking zone.

Note: Some types of pans could cause noise when used on an induction cooking zone. The noise does not mean any failure on the appliance and does not influence the cooking operation.

HOW TO SWITCH ON/OFF THE COOKTOP

Switching ON

Touch the key  until the touch control system is lit (fig. 16). The displays of the cooking zones read “0”.

Notes:

- If the safety Child Lock protection is active, the cooktop can be used only after having deactivated this protection (see chapter CHILD LOCK SAFETY).
- Auto switch-Off: If a cooking zone is not turned On within 15 seconds, the cooktop will automatically switch off.

Figure 16

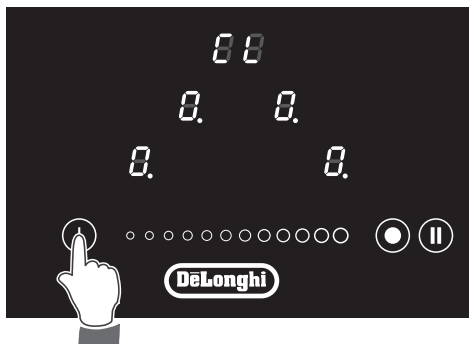

Switching OFF

The cooktop may be switched Off at any time by pressing the key . If any cooking zones are turned On, they will be turned Off.

POWER IGNITION AND ADJUSTMENT OF A COOKING ZONE

To turn On a cooking zone the cooktop must be switched On (see section “HOW TO SWITCH ON/OFF THE COOKTOP”).

- Select a cooking zone by touching the relevant display of the cooking zone to be used (fig. 17).
- Select a setting on the selector [between “1” (minimum) and “9” (maximum)]: touch at one point to “jump” to a specific setting or slide your finger along the selector (fig. 18).
- The cooking zone display shows the selected level.
- The power level can be modified at any time.

Figure 17

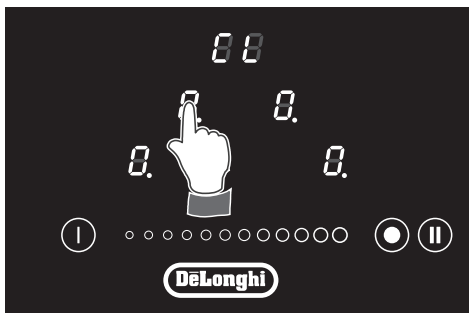

Figure 18

Increase



Decrease



BOOSTER FUNCTION

This function allows the cooking zone to operate at the “Booster” maximum power (above the nominal power) for maximum 5 minutes; it could be used, for example, to rapidly heat up large amount of water.

- The “Booster” function is always limited to a maximum of 5 minutes.
- This function is NOT available on the smaller cooking zones (Ø 160 mm) of models DEIND604, DEIND804.

To activate the “Booster” function:

- Set the power level “9” on the selected cooking zone, then just touch the key  until the relevant display shows “P” (fig. 19).
- At the end of the “Booster” program (5 minutes) the cooking zone is automatically set to the power level “9”.
- Note: if a cooking zone is still hot, it is not possible to use the “Booster” function and “P” will flash if you try to activate. The cooking zone is automatically set to the maximum power level (“9”).

To deactivate the “Booster” function:

- Set a different power level on the selected cooking zone.
or
- Switch Off the cooktop.

IMPORTANT NOTES:

- The “Booster” function is not suitable for use with non water based cooking.
- Do not use this function for heating oil (e.g. deep fat frying).

Figure 19

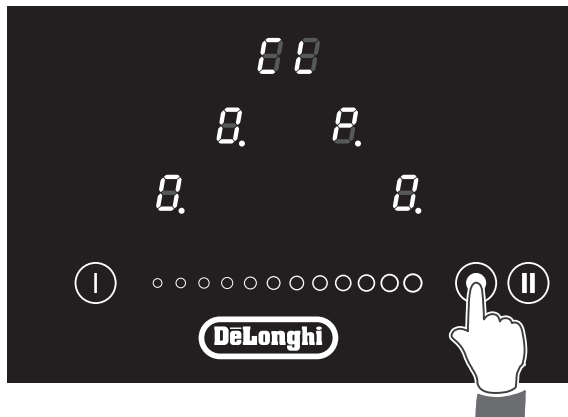

OPERATION TIME LIMIT OF THE COOKING ZONES

Each cooking zone is automatically switched Off after a maximum preset time if no operation is performed.

The maximum preset time limit depends on the set power level, as illustrated in this schedule.

Each operation on the cooking hob by using the touch controls will reset the maximum operation time at its initial value.

POWER LEVEL OF COOKING ZONES	OPERATION TIME LIMIT
1	480 minutes
2	360 minutes
3	300 minutes
4	300 minutes
5	240 minutes
6	90 minutes
7	90 minutes
8	90 minutes
9	90 minutes
P	5 minutes

COOKING ZONE POWER LEVEL	COOKING ZONE Ø 160 mm (*) (Watt power)	COOKING ZONE Ø 160 mm (**) (Watt power)	COOKING ZONE Ø 200 mm (Watt power)	COOKING ZONE Ø 250 mm (Watt power)
1	42	36	70	70
2	70	60	120	120
3	112	100	180	180
4	168	140	276	276
5	252	215	420	420
6	392	336	645	645
7	588	500	960	960
8	896	770	1470	1470
9	1400	1200	2300	2300
P	not available	1400	3000	3000

(*) only for models DEIND604, DEIND804

(**) only for model DEIND603

EXAMPLES OF COOKING POWER SETTING

0	Cooking zone not operating	
1 to 2	Melting Reheating	Sauces, butter, chocolate, gelatine Dishes prepared beforehand
2 to 3	Simmering Defrosting	Rice, pudding, sugar syrup Dried vegetables, fish, frozen products
3 to 4	Steam	Vegetables, fish, meat
4 to 5	Water	Steamed potatoes, soups, pasta, fresh vegetables
6 to 7	Medium cooking Simmering	Meat, lever, eggs, sausages Goulash, roulade, tripe
7 to 8	Cooking	Potatoes, fritters, wafers
9	Frying, roasting Boiling water	Steaks, omelettes, fried dishes Water
P	Rapidly heat up large amount of water	

PROGRAM FOR AUTOMATIC SWITCHING OFF OF A COOKING ZONE

This function permits to set a timer from “ 1 ” to “ 99 ” minutes for automatic turning Off the cooking zone/s.

With the cooktop switched On:

- Select the cooking zone and set the desired power level.
- Within 8 seconds, touch the timer key “ CL ” (the led indicating the programmed zone starts blinking) and set the timer:
 - The display reads “ 0- ”: set the second digit of the timer by using the setting selector. If the value shall be zero touch the display and the second digit (0) will start flashing. Touch the display to confirm o wait a few seconds till the programmer automatically turns to the next step.
 - When the display reads “ -Z ” (where “ Z ” indicates the second digit previously set): set the first digit of the timer by using the setting selector. If the value shall be zero touch the display and the first digit (0) will start flashing. Touch the display to confirm o wait a few seconds till the programmer automatically turns to the next step.
 - The program is now processed (led indicating the programmed zone steady lit).
- The time can be changed at any time following the same procedure here above indicated (selecting previously the cooking zone).
- To program another cooking zone, repeat as described above.

Now the program for automatic switching Off is complete.

At the end of the countdown the cooking zone will switch Off automatically, an acoustic signal (beep) will sound (for 2 minute only), “ 00 ” will flash on the timer display and the led next to the heater display will blink. Touch one of the keys to stop the beep.

Figure 20

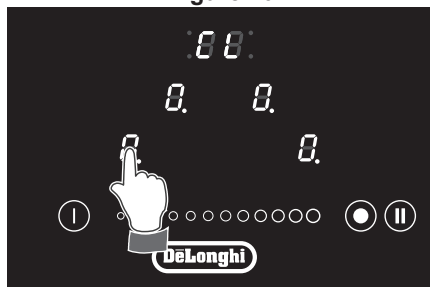

Figure 21

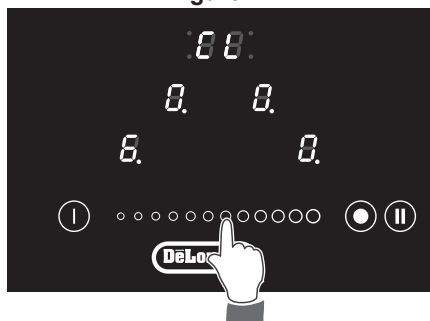

Figure 22



Figure 23



The program for automatic switch Off can be cancelled at any time:

- Select the programmed cooking zone by touching the relevant display of the cooking zone.
- Touch one time the timer key and then, within 8 seconds, the timer display will switch Off.
- **IMPORTANT:** Remember to switch Off the zone manually.

PAUSE MODE

When at least one cooking zone is in operation, the cooking may be paused temporarily by touching the key  (fig. 24).

Already programmed automatic cookings are stopped and do not continue during the pause. The residual heat calculation and operating time limitation continue and are not stopped. The pause mode may last for max 10 minutes. If the pause mode is not terminated within the time, the cooktop switches Off automatically. To deactivate the pause mode touch again the key  and then touch any cooking zone display.

The cooktop may be switched Off at any time with the On/Off key; any possibly program already set (pause mode included) is then terminated.

CHILD LOCK SAFETY

When not using the induction hob, set the Child Lock safety to prevent children from accidentally switching On the cooking zones.





- Ensure all cooking zones are switched Off.
- Simultaneously touch the front right cooking zone display and the key  (models DEIND604, DEIND804) or the central right cooking zone display and the key  (model DEIND603); then touch again the same cooking zone display until “L” lights up (fig. 25a, 25b).
- To deactivate the Child Lock, touch simultaneously the front right or central right cooking zone display (depending on models) and the key ; then touch again the key  until “” lights up on the displays of the cooking zones.

Figure 24



Figure 25a

Models DEIND604, DEIND804

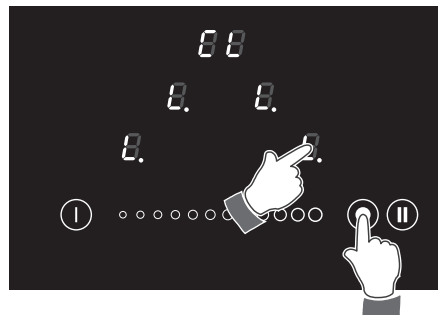
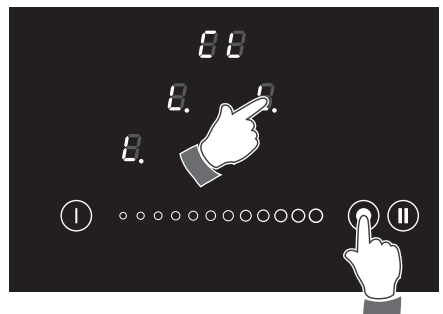

Figure 25b

Model DEIND603



MAXIMUM USABLE POWER FOR THE COOKING ZONES

The left and right cooking zones are controlled by two separate power boards.

Where a power board manages two zones (front/rear LH zones; front/rear RH zones in model with four zones) the maximum total power per each power board is 3700 W.

Should the cooking zones of one power board require more than 3700 W, the last selected power level has priority and the power of the other cooking zone is automatically reduced to the remaining power available.

If this occurs, the cooking zone will display a flashing figure for about 3 seconds before automatically displaying the new power level.

This means for example that:

- When setting a “Booster” programme for the second zone, the setting for the other zone could be reduced to the remaining power available.
- When setting a “Booster” programme for a zone and then another setting on the second zone, if the total power exceed 3700 W the “Booster” programme is deleted and the power reduced to the maximum power available.

THERMAL PROTECTIONS



The induction hob is fitted with safety devices to protect the electronic system and to protect each cooking zone from overheating.

In case of overheating, one of the following automatic functions could be started by the electronic system:

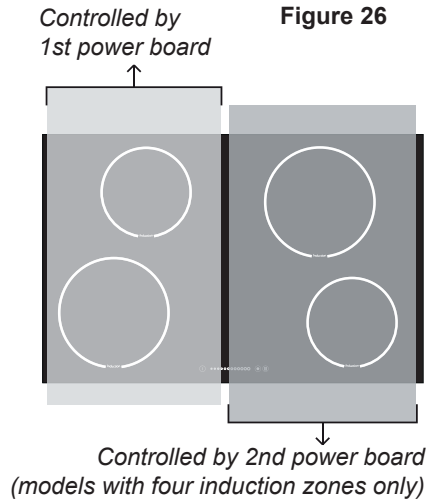
- “Booster” program deleted and power reduced.
- One or more cooking zone switched Off.
- Cooling fan motor of the induction unit switched On.

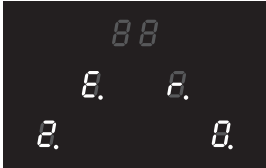
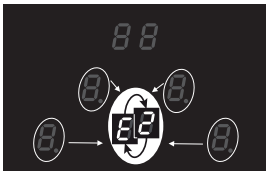

ERROR CODES ON THE DISPLAYS OF THE COOKING ZONES

Error code	Example	What to do
<p>Erxx or Ex (not E2 or EH) or display not operative</p>		<ol style="list-style-type: none"> 1. Switch Off the cooktop and disconnect it from the mains. 2. Wait for about 1 minute, then reconnect the cooktop and turn on the cooking zones. 3. Wait for about 1 minute and if the error message does not appear again the cooking zones can be used. 4. If the error message does not disappear repeat step from 1 to 3. 5. If the problem continues do not use the induction hob and contact your Authorised Service Centre.
<p>E2 or EH</p>		<p>E and 2 or E and H alternating for one or more cooking zones. This indicates an overheating of the cooking zone/s.</p> <ol style="list-style-type: none"> 1. Switch Off the cooking zone/s and leave to cool. 2. If the problem continues do not use the induction hob and contact your Authorised Service Centre.
<p>E6 or display not operative</p>		<p>The cooktop has been incorrectly connected. The appliance shall be connected to the appropriate power supply by a qualified technician.</p>

ADVICE FOR SAFE USE OF THE HOB

- Before switching on make sure that you have the correct cooking zone for the hotplate chosen. It is advisable to put the pan on the hotplate before switching on and to take it away after switching off.
- Use cookware with flat and even bottoms. Uneven bottoms can scratch the glass ceramic surfaces. Be careful that the bottom is clean and dry.
- Do not leave wet or damp lids on the hob.
- The glass-ceramic surface and pans must be clean. Carefully eliminate any food remains (especially containing sugar), dirt etc. with the aid of a cleaning agent.
- Make sure that the handles of cookware do not stick out over the edge of the hob, to avoid them being knocked over by accident. **This also makes it more difficult for children to reach the cooking vessels.**
- Do not lean over the cooking zones when they are switched on.
- Do not drop heavy or sharp objects on the glass ceramic cooktop. **If the surface is broken or damaged unplug the cooktop and contact the after-sales service.**
- Do not put aluminium foil or plastic objects on the cooking zones when they are hot.
- Follow the cleaning instructions carefully.

Figure 27

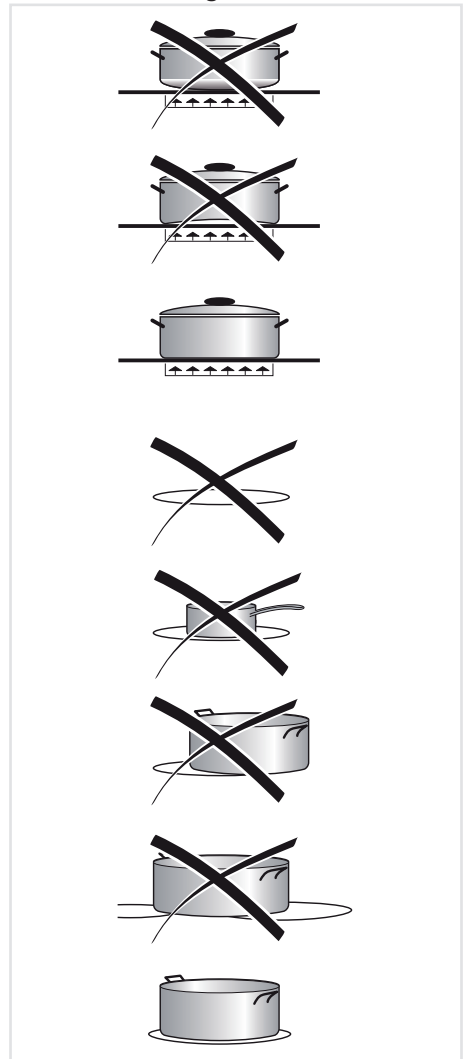
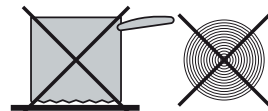

Figure 28

DO NOT USE PANS WITH ROUGH CIRCULAR MACHINED BASE.



CLEANING AND MAINTENANCE

GENERAL ADVICE

- Before you begin cleaning, you must ensure that the appliance is switched off and disconnected from the electrical power supply.
- It is advisable to clean when the appliance is cold.
- Avoid leaving alkaline or acidic substances (lemon juice, vinegar, etc.) on the surfaces.
- Avoid using cleaning products with a chlorine or acidic base.
- Do not use a steam cleaner because the moisture can get into the appliance thus make it unsafe.
- Important: The use of suitable protective clothing/gloves is recommended when handling or cleaning of this appliance.
- Do not scratch the cooktop with cutting or sharp objects.

WARNING!

When correctly installed, your product meets all safety requirements laid down for this type of product category. However special care should be taken around the underneath of the appliance as this area is not designed or intended to be touched and may contain sharp or rough edges, that may cause injury.

CLEANING THE CERAMIC HOB

- Remove spillages and other types of incrustations.
- Dust or food particles can be removed with a damp cloth.
- If you use a detergent, please make sure that it is not abrasive or scouring. Abrasive or scouring powders can damage the glass surface of the hob.
- All traces of the cleaner must be removed with a damp cloth.
- Dust, fat and liquids from food that has boiled over must be removed as soon as possible.
- If they are allowed to harden they become increasingly difficult to remove. This is especially true in the case of sugar/syrup mixtures which could permanently pit the surface of the hob if left to burn on it.
- If any of these products has melted on the ceramic surface, you should remove it immediately (when the surface is still hot) by using a proper scraper to avoid any permanent damage to the surface of the hob.
- Do not put articles on the hob which can melt: i.e plastic, aluminium foil, sugar, sugar syrup mixtures etc.
- Avoid using a knife or other sharp utensil as these may damage the ceramic surface.
- Do not use steel wool or an abrasive sponge which could scratch the surface permanently.

Figure 29



SERVICE AND MAINTENANCE

Servicing the appliance:

Service may be obtained by contacting our Customer Service Centre to locate the nearest Authorised Delonghi Service Agent:

Servicing shall be carried out only by authorized personnel.

The appliance shall not be modified.

Descriptions and illustrations in this booklet are given as simply indicative.
The manufacturer reserves the right, considering the characteristics of the models described here, at any time and without notice, to make eventual necessary modifications for their construction or for commercial needs.

www.delonghi.com.au
www.delonghi.co.nz

Cod. 1104193 - B3

