

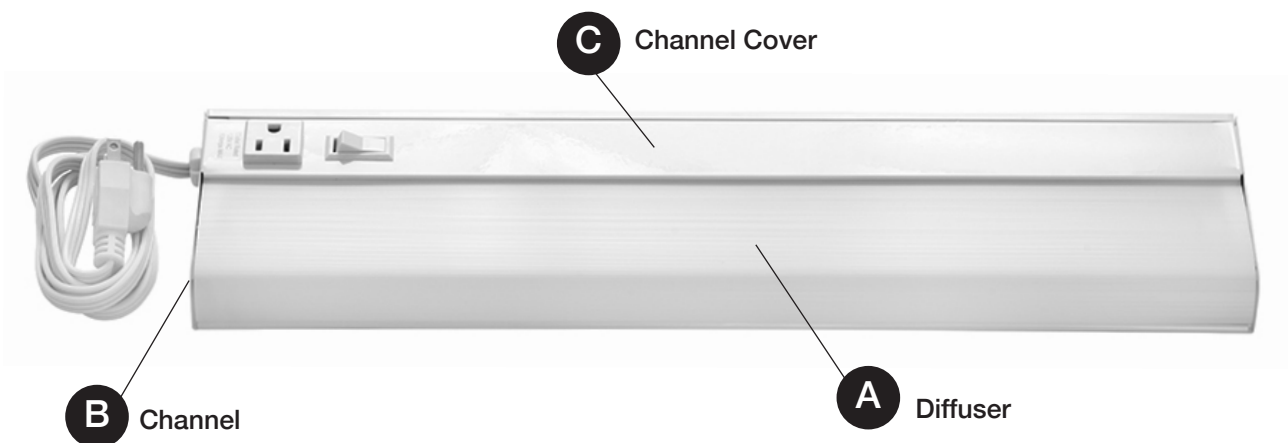

Questions, problems, missing parts?

Before returning to your retailer, call our customer service at 1-800-873-2326
Monday - Friday, 8:00 am-4:30 pm Central Standard Time

PACKAGE CONTENTS



HARDWARE CONTENTS

Note: Hardware not shown actual size.

AA



Mounting Screws
x2



SAFETY INFORMATION

Read all safety precautions and installation instructions carefully before installing or servicing this fixture. Failure to comply with these instructions could result in potentially fatal electric shock and/or property damage.

It is recommended that a qualified electrician perform all wiring. This fixture must be wired in accordance with all national and local electrical codes.

⚠ WARNING: Do not handle any energized fixture or attempt to energize any fixture with wet hands or while standing on a wet or damp surface or in water.

⚠ WARNING: To reduce the risk of electrical shock, and to assure proper operation, this fixture must be adequately grounded. To accomplish proper grounding, there must be a separate ground wire (green) contact between this fixture and the ground connection of your main power supply panel.

CAUTION: Make sure that the power source conforms to the requirements of the fixture (see labels on fixture housing). This fixture is designed for use in a 110-120VAC, 60Hz

CAUTION: Make sure power is off at fuse or circuit breaker box. Check wires for damage or scrapes. If power supply wires are within three inches of the LED driver power supply, use wire suitable for at least 90° C (194° F). NOT FOR USE WITH DIMMING CIRCUITS.

This fixture is intended to be used for general indoor lighting in dry or damp locations only.

Changes or modifications not expressly approved by the party responsible for compliance could void the user's authority to operate the equipment.

Any modifications to this fixture may void the warranty and interfere with the safe operation of the luminaire.

PREPARATION

Disconnect electrical power at fuse or circuit breaker box before installing or servicing any part of this fixture. Carefully remove the fixture from the carton, and check that all parts are included.

If parts are missing or damaged, do not attempt to assemble the product. Contact customer service at 1-800-873-2326 Monday - Friday, 8:00 am-4:30 pm Central Standard Time for replacement parts.

REQUIRED TOOLS

- Phillips Screwdriver
- Flathead Screwdriver
- Drill
- Drill Bits
- Pliers
- Wire Cutter
- Wire Stripper
- Hammer

ASSEMBLY INSTRUCTIONS

INSTALLATION

1. Carefully remove diffuser (A) by squeezing rounded back edge with forefingers while holding front side with thumbs.
2. Remove channel cover (C) from channel (B) by squeezing the cover till it releases from channel body tabs. Remove the parts bag.
3. Position channel body (B) in desired mounting location and mark center point in small location of keyhole slot. Drill pilot hole at marked locations. Screw in mounting screws (BB) leaving space for channel body. Slide channel (B) over mounting screws. Lift and shift channel into position and tighten screws.
4. Install channel cover (C) back onto channel (B) and secure by snapping under channel body tabs. Re-install diffuser (A) onto channel body front lip and push to zip lock back flange onto channel cover.

To power, insert 3 prong plug into wall outlet.

Convenience Outlet: Rated for 120V, 15 AMP MAX

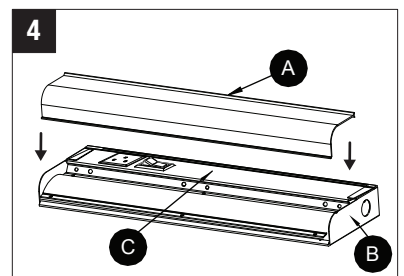
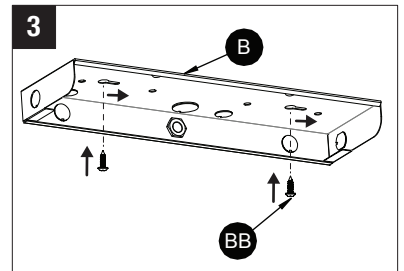
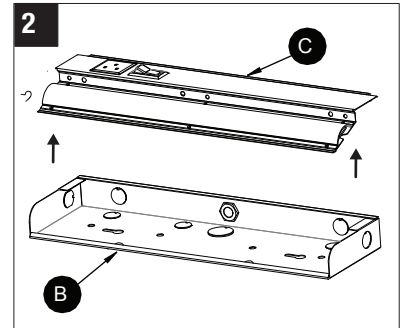
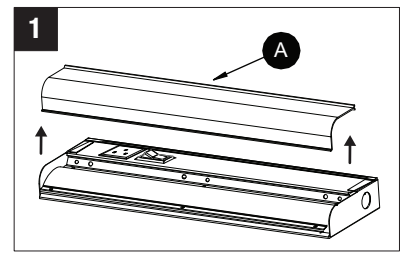

CARE AND MAINTENANCE

Use a dry or slightly damp clean cloth to wipe the surface of the fixture. Do not use any cleaners with chemicals, solvents, or harsh abrasives. If necessary, use a mild soap with water to clean off any dirt or stains.

TROUBLESHOOTING

1. The light does not come on at all:

- a) Make sure the wall switch and circuit breaker are on
- b) Make sure the wiring is correct

2. Fuse blows or circuit trips when light is turned on:

- a) Check for crossed wires, ensure wiring is correct

If unable to fix any of the above issues, please consult a certified electrician.

DISCLAIMER

Changes or modifications not expressly approved by the party responsible for compliance could void the user's authority to operate the equipment.

NOTE: This equipment has been tested and found to comply with the limits for a Class B digital device, pursuant to Part 15 of the FCC Rules and Canadian ICES-005. These limits are designed to provide reasonable protection against harmful interference in a residential installation. This equipment generates, uses and can radiate radio frequency energy and, if not installed and used in accordance with the instructions, may cause harmful interference to radio communications. However, there is no guarantee that interference will not occur in a particular installation. If this equipment does cause harmful interference to radio or television reception, which can be determined by turning the equipment off and on, the user is encouraged to try to correct the interference by one or more of the following measures:

- Reorient or relocate the receiver antenna.
- Increase the separation between the equipment and receiver.
- Connect the equipment into an outlet on a circuit different from that to which the receiver is connected.
- Consult with the dealer or an experienced radio/TV technician for help.

Any modifications to this fixture may void the warranty and interfere with the safe operation of the luminaire. Operation is subject to the following two conditions:

(1) this device may not cause interference, and (2) this device must accept any interference, including interference that may cause undesired operation of the device.

Supplier's Declaration of Conformity
47 CFR § 2.1077 Compliance Information
VTRU18WH / VTRU24WH
AFX Inc.
2345 N. Ernie Krueger Circle
Waukegan, IL 60087
1-800-873-2326

FIVE-YEAR LIMITED WARRANTY: If during normal use, this PATRIOT LIGHTING® lighting fixture breaks or fails due to a defect in material and workmanship within (5) years from the date of original purchase, simply bring this lighting fixture with the original sales receipt back to your nearest MENARDS® retail store. At its discretion, PATRIOT LIGHTING® agrees to have the product or any defective part(s) repaired or replaced with the same or similar PATRIOT LIGHTING® product or part free of charge, within the stated warranty period, when returned by the original purchaser with original sales receipt. This warranty; (1) excludes expendable parts including but not limited to light bulbs; (2) does not cover damage that has resulted from abuse or misuse; and (3) does not cover any losses, labor, injuries to persons/property or costs. This warranty does give you specific legal rights and you may have other rights, which vary from state to state.



Questions, problems, missing parts?

Before returning to your retailer, call our customer service at 1-800-873-2326
Monday - Friday, 8:00 am-4:30 pm Central Standard Time