

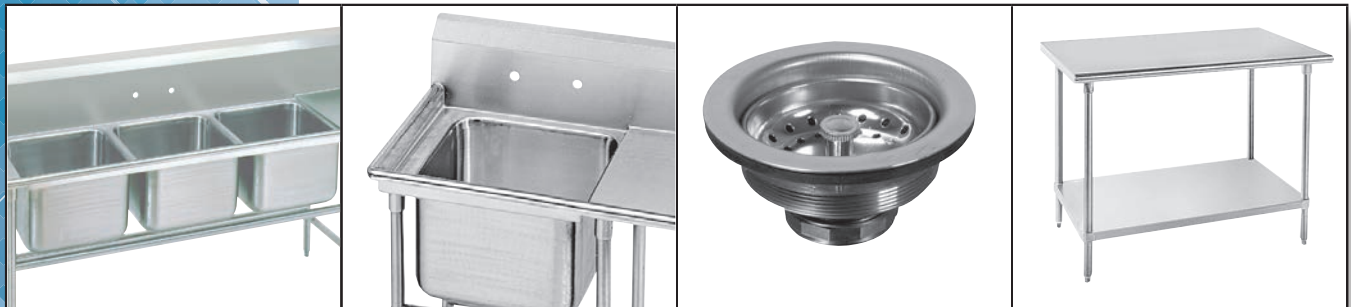

# PRODUCT STANDARDS AND USE INFORMATION

- Sink Bowl Standards
- Drain Flows
- Grease Trap Sizing
- NSF Requirements For Sinks
- Stainless Steel Corrosion Prevention & Cleaning
- Work Table Load Capacities
- Calculating Cubed Ice Volume & Weight



**Customer Service Available To Assist You**

**Call 1-800-645-3166**

**8:30 am - 8:00 pm E.S.T.**

**For Orders & Customer Service:**

**Email:** [customer@advancetabco.com](mailto:customer@advancetabco.com) or **Fax:** 631-242-6900

**For Smart Fabrication™ Quotes:**

**Email:** [smartfab@advancetabco.com](mailto:smartfab@advancetabco.com) or **Fax:** 631-586-2933



# SINK BOWL STANDARDS

## STANDARDS

- One Gallon of Water = 8.34 lbs.
- One Gallon of Water = 231 Cubic Inches
- One Cubic Foot = 7.49 Gallons
- One Cubic Foot Of Water = 62.43

## CAPACITY - Deep Drawn Bowls

BOWL SIZE	Capacity In Gallons Per Compartment
10" x 14" x 5"	2.75
10" x 14" x 10"	5.50
14" x 16" x 10"	9.35
14" x 16" x 12"	11.25
16" x 20" x 12"	15.70
16" x 20" x 14"	18.40



## CAPACITY - FC, FS & FE Series Fabricated Sinks

$$L \times W \times D \div 231 = \text{Gallons}$$

(Inches)

## DRAIN FLOW

DRAIN MODEL #	I.P.S.	DRAIN FLOW
K-6 (Basket Type)	1-1/2"	7 gpm
K-5 (Twist)	1-1/2"	15 gpm
K-15 (Twist)	2"	15 gpm

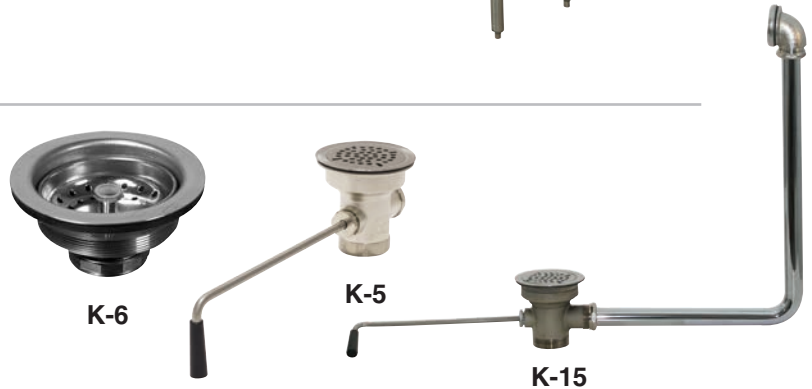

## GREASE TRAP SIZING

**Grease Trap Sizing** is determined by the total volume of water that will drain from a sink unit in one minute.

**SIZE IN POUNDS** = 1.50 x number of compartments x drain flow.

*1.50 = 75% Water Volume of Sink x 2 (K Factor of Volume to Weight)*

## SIGNIFICANT NSF REQUIREMENTS FOR SINKS



- Drainboards, when provided, must have a splash and must be integrally welded to the sink.
- Drainboards are to be sized such as that the LEFT TO RIGHT dimension of the drainboard is equal to or greater than the SMALLER DIMENSION OF THE SINK BOWL OPENING.
- Sinks are considered as FOOD ZONE. Therefore, ONLY 300 Series, 200 Series and Type 430 Stainless Steel are the approved materials. (Type 400 & 409 Stainless Steel are not acceptable)

# TABLE TOP LOAD CAPACITIES

For Flat Top Work Table With Undershef	Weight Capacity For Distributed Load In Lbs.		
	Up To 60" In Length	61" To 84" In Length	Over 84" With Center Leg
14 Gauge Table Top	1000	800	1500
16 Gauge Table Top	800	600	1200
18 Gauge Table Top	400	300	500
14 Gauge Equipment Stand (ES/EG Series)	1000	1000	1500
Special Value Equipment Stand (ES-LS/ EG-LG Series)	600	600	N/A
Standard Undershef (Stainless Or Galvanized)	300	300	450

## ADJUSTMENTS TO THE ABOVE VALUES:

- **Table Tops With 5" Tall Or 10" Tall Rear Splash With 1" Or 2" Return**  
Increases capacity of top by 10% (Multiply by 1.1)
- **Table Tops With Open Base Instead Of Undershef (With Rear Cross Brace Installed)**  
Reduces capacity of top by 20% (Multiply by 0.8)
- **Adding An Extra Set Of Legs In The Center Of A Table (Not Available On All Table Series)**  
Increases top and undershef capacity by 50% (Multiply by 1.5)
- **TA-366A Reinforced Understructure Under Table Top (Not Available On All Table Series)**  
Increases the capacity of a table top by 30% (Multiply by 1.3)
- **TA-366 Reinforced Understructure On Undershef (Not Available On All Table Series)**  
Increases capacity of the undershef by 30% (Multiply by 1.3)
- **Upgrade Stainless Undershef To 16 Gauge (TA-94) (Not Available On All Table Series)**  
Increases undershef capacity by 20% (Multiply by 1.2)
- **Upgrade Stainless Undershef To 14 Gauge (TA-94A) (Not Available On All Table Series)**  
Increases undershef capacity by 30% (Multiply by 1.3)

### PLEASE NOTE:

**MAXIMUM LOAD** On Table (Top And Undershef Combined)  
With all adjustments above cannot exceed 1800 pounds

Tables With Casters Are Limited By The Capacity Of The Selected Caster As Well

# CALCULATING ICE VOLUME AND WEIGHT

## USE THE FOLLOWING FORMULA:

1. Calculate Cubic Area of Ice Liner - Multiply Length x Width x Depth x 1728 = Total Cubic Feet  
(i.e, 12" x 12" x 12" ÷ 1728 = 1 Cu Ft.)
2. Cubed Ice = 40 Lbs. Per Cubic Foot.
3. Multiply Volume (Ice Liner Cubic Feet) x 40 Lbs./Cu Ft. = Total Weight

