

GAS RANGE TOP

HEAVY DUTY GAS RANGE TOP

MODELS:

KM-HGRT30-SS, KM-HGRT36-SS, KM-HGRT48-SS

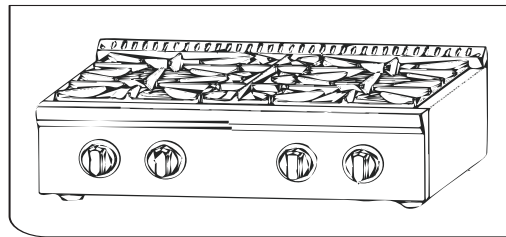

KM-HGRT30-SS

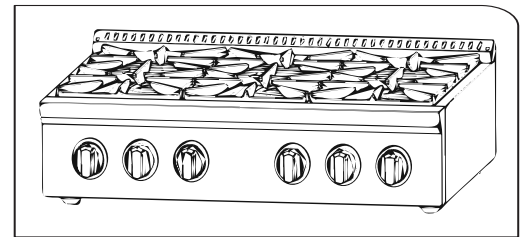

KM-HGRT36-SS

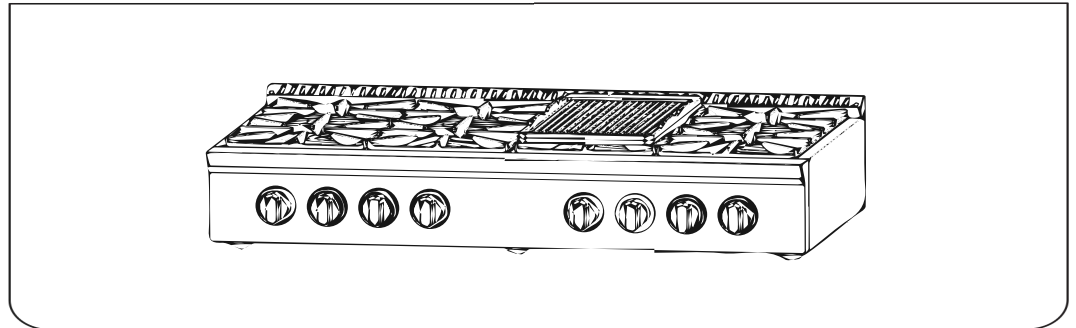

KM-HGRT48-SS

INSTALLATION GUIDE

SPECIFICATIONS, INSTALLATION, AND MORE

Intended for household use. Unit must be kept clear of combustibles at all times.

For any service-related issues, please contact us:

Phone Number: 718-576-6342

Email address: support@koolmore.com

Thank you for choosing KOOLMORE Appliances.

At koolmore Appliances, we are proud to provide you with innovative technology and exceptional quality to simplify the way you live. Among other things, registration of your appliance ensures that we can deliver important product information and warranty details

This manual contains instructions on how to properly install and set up your new appliance, as well as insights into many of the unique features that our product offers. Be sure to read all safety instructions before using the product. Please keep this manual for future reference, as it contains the answers to questions you may have as you begin to cook.

Contents

Safety Instructions	4~5
Installation Instructions	6~13
Cooktop Operation	14~16
Care & Cleaning	17
Troubleshooting	18
Ng to LPG Conversion	19-22
Warranty.....	23



WARNING

If the information in this manual is not followed exactly, a fire or an explosion may result causing property damage, personal injury or even death.

Do not store or use gasoline, liquid propane cylinder or other flammable vapors and liquids in the vicinity of this appliance.

What to do if you smell gas?

Do not try to light any appliance.

Do not touch any electrical switch.

Do not use any phone in your residence.

Immediately call your gas supplier from a neighbor's phone. Follow the gas supplier's instructions.

If you cannot reach your gas supplier, call the fire department.

For installation and service of your rangetop product, it must be performed by a licensed installer, an approved service agency or your gas supplier.

SAFETY INSTRUCTIONS

Definitions

 This is a safety alert symbol. It will alert you to potential personal or property safety hazards. Obey all safety messages to avoid any property damage, personal injury or death.



WARNING indicates a potentially hazardous situation which, if not avoided, could result in serious injury or death.



CAUTION indicates a moderate hazardous situation which, if not avoided, could result in minor or moderate injury.



CAUTION – when used without the safety alert symbol, indicates a potentially hazardous situation which, if not avoided, could result in property damage.



IMPORTANT used for installation, operation and maintenance information that are not related to safety.

If the information in this manual is not followed exactly, a fire or an explosion may result causing property damage, personal injury or even death.

Do not store or use gasoline, liquid propane cylinder or other flammable vapors and liquids in the vicinity of this appliance.

Save this manual for future references.

SAFETY INSTRUCTIONS

What to do if you smell gas?

- Do not try to light any appliance.
- Do not touch any electrical switch.
- Do not use any phone in your residence.
- Immediately call your gas supplier from a neighbor's phone. Follow the gas supplier's instructions.
- If you cannot reach your gas supplier, call the fire department.

IMPORTANT

The installation and service of your rangetop product must be performed by a licensed installer, an approved service agency or your gas supplier.



Do not store or use gasoline, liquid propane cylinder or other flammable vapors and liquids in the vicinity of this appliance.

The installation and service of your rangetop must be performed by a qualified installer, an approved service agency or the gas supplier.

Gas appliances can cause minor exposure to four of these substances, namely benzene, carbon monoxide, formaldehyde and soot, caused primarily by the incomplete combustion of natural gas fuel. When operating your rangetop on natural gas, the flames from the burners should be blue in color. In addition, the flames should be stable, free of yellow tipping, excessive noise and lifting. However, this yellow tipping should be restricted to the primary flame kernels only. Properly adjusted burners, indicated by a bluish rather than a yellow flame, will minimize incomplete combustion. Exposure to those substances can be minimized by venting with an open window or use of a ventilation fan or hood.

ELECTRICAL GROUNDING INSTRUCTIONS

IMPORTANT

This indoor cooking appliance is equipped with a three-prong (grounding) plug for your protection against shock hazard and should be plugged directly into a properly grounded three-pronged receptacle. DO NOT cut or remove the grounding prong from this plug.

INSTALLATION AND OPERATION INSTRUCTIONS

To ensure proper and safe operation, read all instructions before using the product. Install or locate the product only in accordance with the provided Installation Instructions.



- All servicing should be performed to a qualified technician.
- Do not attempt to adjust, repair, service or replace any part of your appliance unless it is specifically recommended in this guide.
- Do not use the rangetop for warming or heating the room.
- Do not leave children alone or unattended in the area where the rangetop is in use. Never allow them to sit or stand on any part of the rangetop. Do not let children play with the rangetop.
- Have the technician show you the location of the gas shut off valve and how to shut it off in an emergency situation.
- Always disconnect power to appliance before any type of servicing.
- Do not use abrasive or caustic cleaners or detergents on this appliance. They may cause permanent damage to the surface.
- When cooking, set the burner controls so that the flame heats only the bottom of the utensil and does not overlap at the sides of the utensil.
- Utensils (pots and pans) that conduct heat slowly, i.e. glass pots, should be used in conjunction with burner flames at a low or medium setting.
- Turn off all controls and wait for appliance parts to cool down before touching them. Do not touch the burner grates or surrounding areas until cool.
- Do not use water on grease fires.
- Clean appliance with caution.
- Always turn pot handles to the side or back of the rangetop. Do not turn handles towards the area where they can be easily burned. Handles should not extend over the adjacent burners.
- Use the rangetop only for cooking tasks as outlined in this manual. When using the rangetop, do not touch the grates, burner caps, burner bases, or any other parts in proximity to the flame. These components may be hot enough to cause burns.
- Use dry pot holders. Moist or damp pot holders on hot surfaces may result in burns from steam.
- Remove pot holder away from hot surface areas.
- Do not use a towel or other bulky cloth.
- Do not heat unopened food containers. Build up of pressure may cause the container to explode and result in injury.

INSTALLATION INSTRUCTIONS

IMPORTANT

Keep appliance area clear and free from combustible materials, gasoline, and other flammable vapors.

Gas Supply Requirements

Installation of this rangetop must conform with local codes, or in the absence of local codes, the National Fuel Gas Code, ANSI Z223.1 / NFPA 54. In Canada, installation must conform to the current natural Gas Installation /code, CAN 1-1.1-M81 and with local codes where applicable. This rangetop has been design-certified according to ANSI Z21.1b-2012 latest edition.

A statement of the maximum gas supply pressure in accordance with the inlet pressure rating of the gas appliance pressure regulator supplied.

MINIMUM GAS SUPPLY PRESSURE TO APPLIANCE FOR LP GAS---14.0 IN.W.C.
MINIMUM GAS SUPPLY PRESSURE TO APPLIANCE FOR NG --- 6 IN.W.C.
APPLIANCE REGULATOR IS SET AT 5.0 IN. W.C. OUTLET PRESSURE.

Do not obstruct the flow of combustion air into the rangetop and ventilation air away from the rangetop.

Before installing the rangetop, you must locate and secure the included anti-tip bracket to the wall for your rangetop.

CAUTION

The use of cabinets for storage above the appliance may result in a potential fire hazard. Combustible items may ignite; metallic items may become hot and cause burns. If a cabinet storage is to be provided, the risk can be reduced by installing a rangetop hood that projects horizontally a minimum of 5" (12.7cm) beyond the bottom of the cabinets.

WARNING

The appliance shall not be used for space heating. This information is based on safety considerations. All openings in the wall behind the appliance and in the floor under the appliance shall be sealed.

INSTALLATION INSTRUCTIONS

Dimensions and Clearances

The rangetop may be installed flush to the rear wall. You may install a non-combustible material on the rear wall above the rangetop and up to the vent hood. It is not necessary to install non-combustible materials behind the rangetop below the counter top height.

The minimum distance from the side of the rangetop above the counter top to combustible sidewalls must be at least 10 inches.

INSTALLATION INSTRUCTIONS

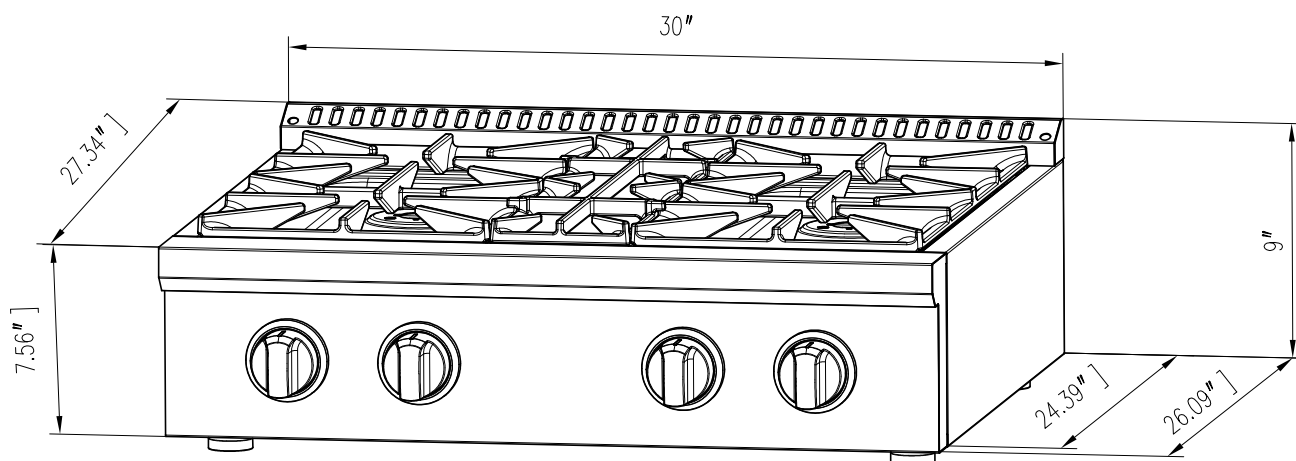

**Product features may not match. Image meant for dimension reference only.*

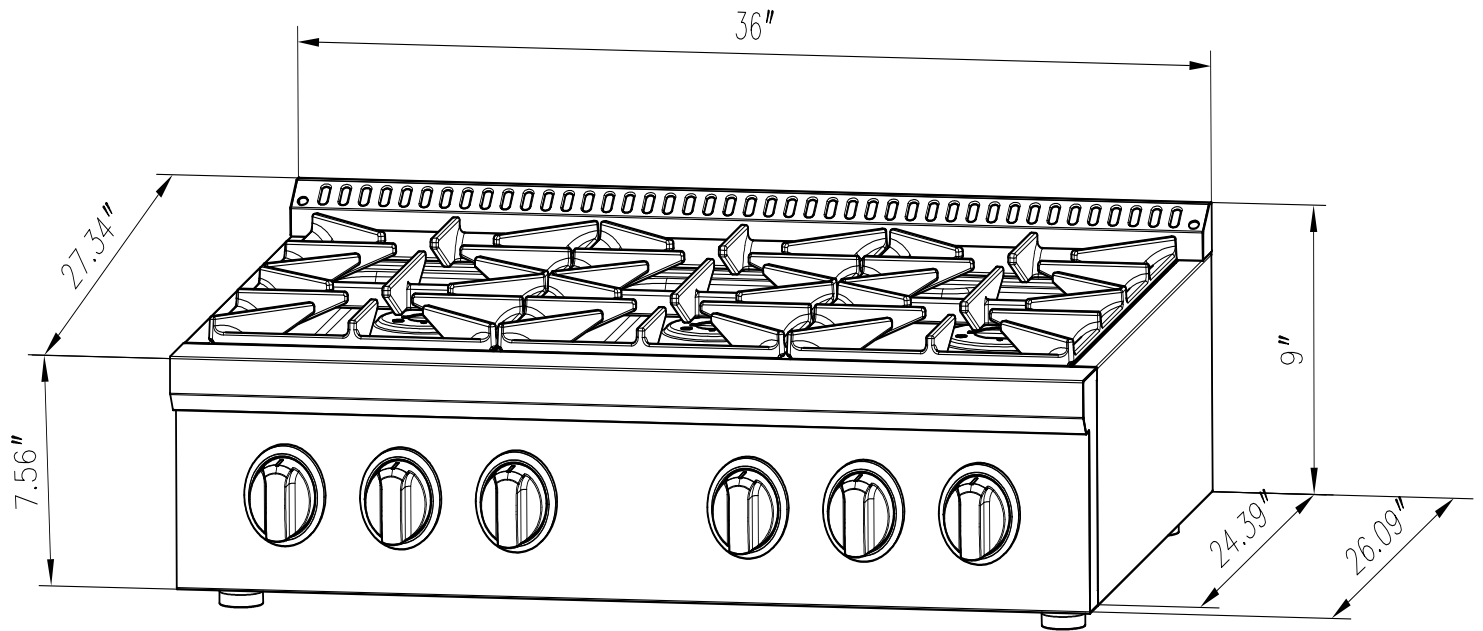

**Product features may not match. Image meant for dimension reference only.*

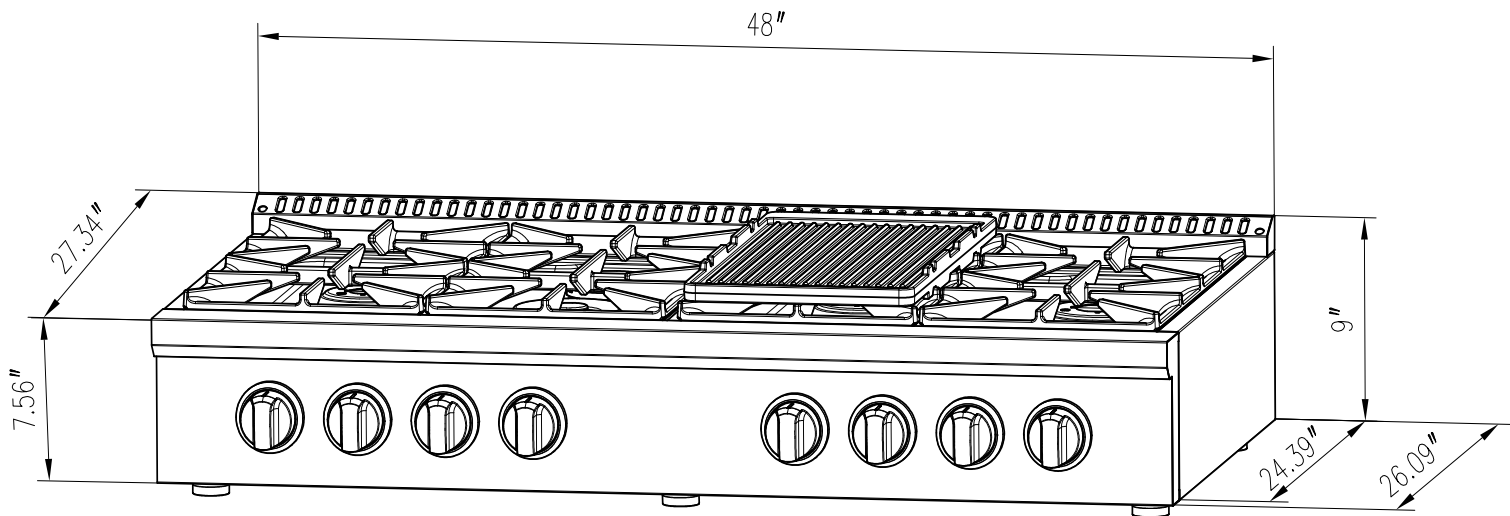

**Product features may not match. Image meant for dimension reference only.*

Installation

Electric Power Supply Requirements

Your rangetop must be electrically grounded in accordance with local codes or, in the absence of local codes, in accordance with the National Electrical Code (ANSI/NFPA 70, latest edition). In Canada, electrical grounding must be in accordance with the current CSA C22.1 Canadian Electrical Code Part 1 and/or local codes. A copy of this standard may be obtained from: National Fire Protection Association, 1 Batterymarch Park, Quincy, Massachusetts 02269-9101.

The power supply must be the correct polarity. Reverse polarity will result in continuous sparking of the electrodes, even after flame ignition. If there is any doubt as to whether the power supply has the correct polarity or grounded, have it checked by a qualified electrician.

Use 120V, 60Hz, and properly grounded branch circuit protected by a 15-amp or 20-amp circuit breaker or time delay fuse.

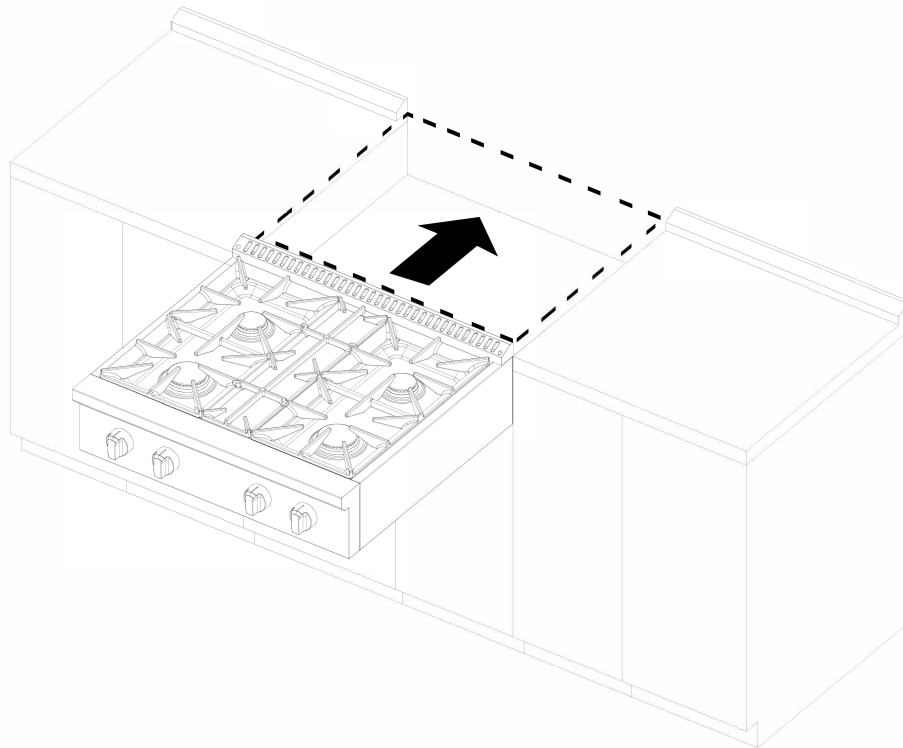

WARNING

Electrical Grounding Instructions: this indoor gas cooking appliance is equipped with a three-prong (grounding) plug for your protection against shock hazard and should be plugged directly into a properly grounded three-pronged receptacle.

Do Not cut or removes the grounding prong from the plug.

Caution Label all wires prior to disconnection when servicing controls. Wiring errors can cause improper and dangerous operation. Verify proper operation after servicing.

INSTALLATION INSTRUCTIONS

Grounding

- The power cord is equipped with a three-prong (grounding) plug which mates with a standard three-prong grounding wall receptacle to minimize the possibility of electrical shock hazard from the rangetop.
- All cord connected appliance shall include instructions relative to location of the wall receptacle and a warning to the user to disconnect the electrical supply before serving the appliance.
- Where a standard two-prong wall receptacle is encountered, it is the responsibility and obligation of the customer to have it replaced with a properly grounded three-prong wall receptacle. Do not cut or remove the grounding prong from the power cord.

Connect Rangetop to Gas Supply

- Install a manual gas line shut-off valve in the gas line in an easily accessed location outside the rangetop in the gas piping external to the appliance for the purpose of turning on or shutting off gas to the appliance.
- Install male $\frac{1}{2}$ " flare union adapter to $\frac{1}{2}$ " NPT internal thread elbow at inlet of regulator. On models equipped with standard twin burners, install the male pipe thread end of the $\frac{1}{2}$ " flare union adapter to the $\frac{1}{2}$ " NPT internal thread at inlet of pressure regulator. Use a wrench on the regulator fitting to avoid damage.
- Install male $\frac{1}{2}$ " or $\frac{3}{4}$ " flare union adapter to the NPT internal thread of the manual shut-off valve, taking care to secure the shut-off valve to keep it from turning.
- The gas supply pressure for checking the regulator setting is 6in (Natural Gas) and 11inch (LP gas) connect flexible gas line connector to the regulator on the rangetop. Position rangetop to permit connection at the shut-off valve.
- When all connections have been made, check that all rangetop controls are in the "off" position and turn on the main gas supply valve.
- Leak testing of the appliance shall be conducted according to the manufacture's instructions .Use some soap water (50% water and 50% soap) or a leak detector at all joints and connections to check for leaks in the system. Do not use a flame to check for gas leaks.
- The appliance must be isolated from the building's gas supply piping system by closing its individual manual shut-off valve during any pressure testing of the gas supply piping system at test pressure equal to or less than $\frac{1}{2}$ psig (3.5kPa).

Hood/Composite Overlay Install

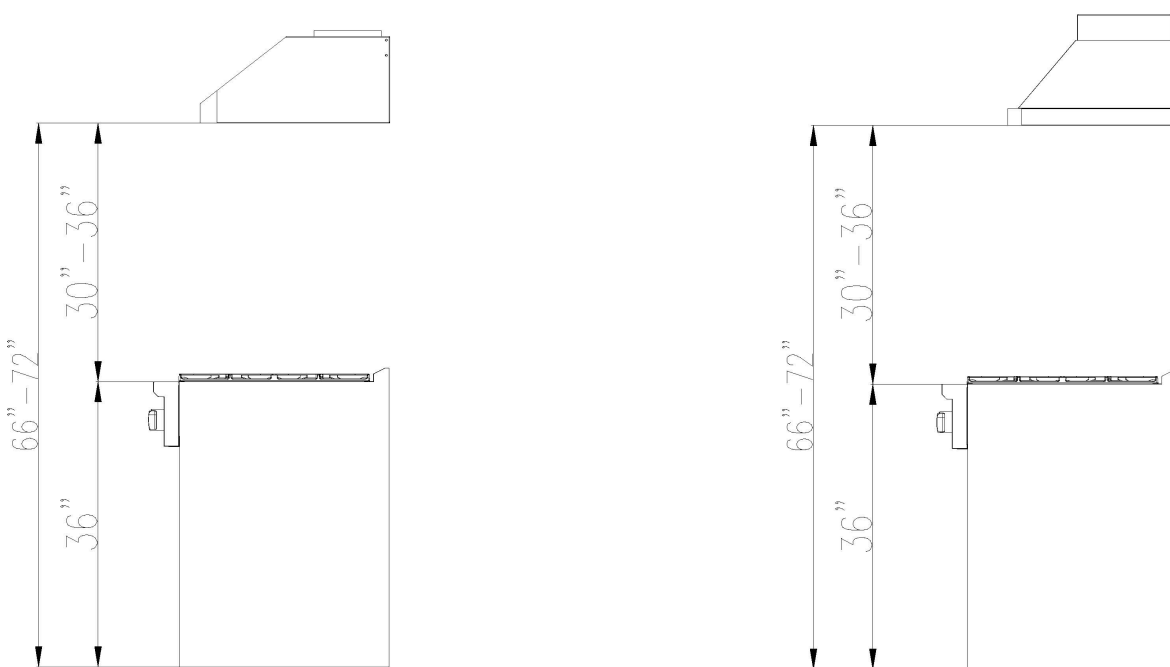

The bottom of the hood should be 30" min. to 36" above the counter top. This would typically result in the bottom of the hood being 66" to 72" above the floor. These dimensions provide safe and efficient operation of the hood.

After Installation:

Check ignition of cooktop burners.

Check the air shutter adjustment – sharp blue flame, with no yellow tipping or lifting flames.

Check for gas leaks at all gas connections (using a gas detector, never a flame).

COOKTOP OPERATION

Surface Burner Ignition



Push to release gas.



Turn to Ignite and 'Hi' position.



Adjust to appropriate flame height.

To light the surface burners, push and turn the appropriate control knob counter clockwise to a “Hi” position. You will hear a clicking noise – the sound of the electric spark igniting the burner.

Once burner ignition has been achieved, turn the burner control knob to adjust the flame size. If the knob stays at “Hi”, it will continue to click.

NOTE: When one burner is turned to the “Hi” position, all the burners will spark. Do not attempt to disassemble or clean around any burner while another burner is on. Do not touch any burner cap, burner base, or igniter while the igniters are sparking.

Heat Settings:

Hi	Ignites the burners.
Simmer	Melting small quantities, steaming rice, warming food, melting chocolate or butter.
Low	Melting large quantities.
Low-Medium	Low-temperature frying, simmering large quantities, heating milk, cream sauces, gravies.
Medium	Sautéing and browning, braising, pan-frying, maintaining slow boil on large quantities.
Medium – Hi	High-temperature frying, pan boiling, maintaining slow boil on large quantities.
Hi	Boiling liquid quickly, deep frying.

Cooktop Operation

Simmer and Boil

- A smaller flame will give the best simmer results. Small flames offer precise cooking performance for delicate foods, keeping food warm, melting chocolate or butter, and for cooking that need to cook over low heat for a long time.
- The highest (larger) flame settings provide the maximum heat that is available on your rangetop. This setting should be used for heavy cooking loads such as water boiling and pasta cooking.

Flame Size

- When you select the flame size, watch the flame when you turn the knob.
- Any flame larger than the bottom of the cookware is wasted.
- The flame should be steady and blue in color. Foreign material in the gas line may cause an orange flame during initial operation.

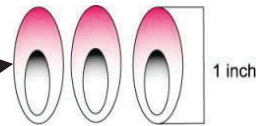

*Approximate 1
1/2" Flame Height*

Power Failure

- If the gas does not ignite within four seconds, turn off the valve and allow at least five minutes for any gas to dissipate. Repeat the lighting procedure.
- If the power fails, the surface burners can be lighted manually. Hold a lighted match near a burner and turn knob counterclockwise to “HI”. After burner lights, turn knob to setting.

Cooktop

- To prevent the cooktop from discoloring or staining, clean cooktop after each use, and wipe up acidic or sugary spills as soon as the cooktop has cooled.
- The sealed burners of your rangetop are not secured to the cooktop and are designed to be removed. Boil overs or spills will not seep underneath the cooktop. The burners should be cleaned after each use.

Cooktop Operation



WARNING

FOOD SAFETY

According to the United States Department of Agriculture: DO NOT hold foods at temperatures between 40°F to 140°F more than 2 hours. Cooking raw foods below 275°F is not recommended.



WARNING

Never use this appliance doors or drawers such as stepping. Leaning or setting on the doors or drawers, may result in hazards and injuries

Burner Grates

1. The grates must be properly positioned before cooking. Improper installation of the grates may result in scratching of the cooktop and / or poor combustion.
2. Do not operate the burners without a pan or utensil on the grates



Care and Cleaning

Rangetop

- To avoid electrical shock or burns, turn off all controls and ensure the cooktop is cool before cleaning.
- Before cleaning the cooktop, ensure that all burners are turned off and that all components are cool enough to safely touch.
- Do not use harsh or abrasive cleaning agents, waxes, polishes, or commercial cooktop cleaners to clean the cooktop.
- Use only a sponge, soft cloth, fibrous or plastic brush, and nylon pad for cleaning.
- Always dry components completely before using the cooktop.

Stainless Steel Surfaces

- Do not use any cleaning product containing chlorine bleach.
- Do not use a steel-wool pad; it will scratch the surface.
- Use a hot, damp cloth with a mild detergent. Use a clean, hot, damp cloth to remove soap. Dry with a dry, clean cloth.

Metal Finishes

- Wash with soap and water, glass cleaner, or mild liquid sprays.

Plastic Finishes

- When control panel trim and end caps are cool, clean with soap and water, rinse and dry.
- Use a glass cleaner and soft cloth.

Troubleshooting

Before you call for service, please review the potential problem / possible causes and remedies shown in the table below.

Nothing works	Power supply is not energized.	Have an electrician check the power supply, including the house circuit breaker, wiring and fuses
Top burners do not light or do not burn evenly	Plug on rangetop is not completely inserted in the electrical outlet. Burner holes on the side of the burner may be clogged.	Make sure the unit is properly connected to the power supply Remove the burner heads and clean them. Check the electrode area for burned-on food or grease.
Burner flames very large and yellow.	Burner bezel ports are clogged. Burner ports or burner caps are not positioned properly. Cooktop is being operated with the wrong type of gas. Regulator is not installed, is faulty, or is set for the wrong type of gas.	Clean burner bezel ring ports with straightened paper clip, needle, or wire. Remove and carefully re-install burner bezel and caps. Ensure that the type of cooktop matches the natural gas supply. Check installation, replace regulator, or set regulator for proper gas.
Sparking but no flame ignition.	Gas shut-off valve is in the 'OFF' position.	Turn shut-off valve to the 'ON' position.
Igniters spark continuously after flame ignition.	Power supply polarity is reversed. Igniters are wet or dirty.	Have polarity corrected. Dry or clean igniters.
Burner flame goes out at low setting.	Low gas supply pressure. Air intake holes around knobs are obstructed.	Contact gas company. Remove obstruction.

Instructions for Converting Rangetop to Operate on Liquefied Petroleum Gas

INSTALLATION AND SERVICES MUST BE PERFORMED BY A QUALIFIED INSTALLER

IMPORTANT: SAVE INSTRUCTION MANUAL FOR THE LOCAL INSPECTOR'S USE.
READ AND SAVE THESE INSTRUCTIONS FOR FUTURE REFERENCE

⚠ WARNING This conversion kit must be installed by a qualified service technician in accordance with the manufacturer's instructions and all applicable codes and requirements of the authority having jurisdiction. Failure to follow instructions may result in fire, explosion or production of carbon monoxide causing property damage, personal injury or loss of life. The qualified service agency is responsible for the proper installation of this kit. The installation is not proper and complete until the operation of the converted appliance is checked as specified in the manufacturer's instructions supplied with this kit.

⚠ WARNING Before proceeding with the conversion, shut off the gas supply before disconnecting electrical power to the rangetop. Be sure power supplies are off before installing the conversion kit. Failure to do so could cause serious bodily injury.

Determine the combination of top burners that are featured on your rangetop. Identify the parts you need from this kit to complete the L.P. conversion. When burners are converted from natural to L.P. the BTU ratings are as follows:

Top Burner	6,000 BTU L.P. Gas	[0.74mm]
Top Burner	9,000 BTU L.P. Gas	[0.90mm]
Top Burner	12,000 BTU L.P. Gas	[1.0mm]
Top Burner	15,000 BTU L.P. Gas	[1.16mm]
Top Burner	20,000 BTU L.P. Gas	[0.89! +0.53mm]

*Note: For operation at elevations above 2000ft., appliance rating shall be reduced at the rate of 4% for each 1000 ft. above sea level .

IMPORTANT: After replacing the natural gas to LP orifices, be sure to keep the original factory installed natural gas orifices for future rangetop conversion back to natural gas.

The original orifices are Nature Gas:

Top Burner 6,000 BTU	[1.07mm]
Top Burner 9,000 BTU	[1.36mm]
Top Burner 12,000 BTU	[1.57mm]
Top Burner 15,000 BTU	[1.79mm]
Top Burner 20,000 BTU	[1.36*2+0.73mm]

Tools Required for L.P. Conversion:

- 2mm Allen Wrench
- 3/8 & 1/2 & 5/8" [19mm] Open End Wrench
- 1/8" Wide Flat Blade Screwdriver
- Philips Screwdriver
- 7mm Nut Driver
- 1/4 Nut Driver
- Adjustable wrench.

Instructions for Converting Rangetop to Operate on Liquefied Petroleum Gas

1. Convert the Pressure Regulator

To access the gas regulator, pull the rangetop away from the cabinet wall. The gas regulator is located at the bottom right corner of the rangetop.

- a. Electrical shock hazard can occur and result in injury or death. Disconnect electrical power to the rangetop before servicing. Do not remove regulator or allow it to turn during servicing.
- b. Unscrew the cap from the regulator. Do not remove the spring from the regulator.
- c. Unscrew the insert from the cap and turn it over so the longer stem is facing the cap. Replace insert on

2. Convert Top Burner for LP/ Propane Gas



Save the natural gas orifices removed from the appliance for possible future conversions to natural gas. You should use the following process to convert to Natural gas. Take extra care when handling steel parts.

- a. Remove cooking grates, burner caps and inner burner rings.
- b. Lift off outer burner heads and burner bases.
- c. Remove the factory installed natural gas orifices from the center of the orifice holders using a 7mm nut driver. Remember to keep the original natural gas orifices for future conversions back to natural gas. Replace the LP orifice in each orifice holder. Tighten each orifice until snug. Use caution not to over tighten.



Care should be taken when removing and replacing gas components. Use proper support to prevent damage to components.

Instructions for Converting Rangetop to Operate on Liquefied Petroleum Gas

5. Convert Gas Valves for LP/Propane Gas

- a. Remove control knobs.
- b. Using a flat screwdriver, adjust main burner bypass jets toward to $\frac{1}{4}$ circle for LP until the flame is normal.



CAUTION

Care should be taken when removing and replacing gas components. Use proper support to prevent damage to components.

This rangetop can be used with LPG(Liquid Propane Gas and NG (Natural Gas). It is shipped from the factory adjusted for use with NG. Conversion nozzles are included in this plastic bag. Follow instructions in the manual (page 19-22) for gas conversion.

Attention: Affix this label as close as possible to the conversionplate on the rangetop.

Rangetop model: _____ This rangetop was converted on _____ (day/month/year) to LPG
by _____ (name and address of company making this conversion)
which accepts the liability that this conversion has been properly made.

LPG Supply Pressure 10" w.c.

Instructions for Converting Rangetop to Operate on Liquefied Petroleum Gas

6. Reconnect Gas and Electrical Supply to Rangetop

Leak testing of the appliance shall be conducted according to the installation instructions provided with the rangetop.

Checking for Manifold Gas Pressure

If it is necessary to check the manifold gas pressure, remove the burner cap, inner ring, outer burner head and burner base of the right front top burner and connect a manometer (water gauge) or other pressure test device to the burner orifice. Use a rubber hose with inside diameter of approximately $\frac{1}{4}$ " and hold the end of the tube tight over the orifice. Turn the gas valve on. For a more accurate pressure check, have at least two (2) other top burners burning. Be sure that the gas supply (inlet) pressure is at least one inch above the specified manifold pressure. The gas supply pressure should never be over 14" water column. When properly adjusted the manifold water column pressure is 10" for LP/Propane gas or 5" for Natural Gas

CAUTION

Do not use a flame to check for gas leaks

- a. Disconnect the rangetop and its individual shut -off valve from the gas supply piping system during any pressure of that system at test pressures greater than 14" of water column pressure (approximately $\frac{1}{2}$ " psig)
- b. The appliance must be isolated from the gas supply piping system by closing its individual manual shut -off valve during any pressure testing of the supply system at test pressure equal to or less than 14" water column pressure (approximately $\frac{1}{2}$ " psig)

7. Installation of New LP / Propane Rating / Serial Plate

Record the model and serial number on the LP / Propane Rating serial plate provided in this kit. The information can be obtained from the existing Rating / Serial plate. Place the new plate as close as possible to the existing Rating / Serial plate on the rangetop.

Rangetop Warranty

Your **RANGETOP** has been inspected and tested and is warranted subject to following for a period to 24 months from the date of purchase against defects in workmanship and materials. During this period, we undertake to repair or replace any defective part which was originally defective in our opinion. This warranty is null and void if the appliance is used for commercial purposes.

KOOLMORE Appliances will not pay for:

1. Service calls to correct the installation of your **RANGETOP**, to instruct you how to use your **RANGETOP**, to replace house fuses or correct house wiring or plumbing, or to replace light bulbs other than as noted above.
2. Repairs when your **RANGETOP** is used in other than normal, single-family household use.
3. Pickup and delivery. Your **RANGETOP** is designed to be repaired in the home.
4. Damage resulting from accident, alteration, misuse, abuse, fire, flood, improper installation, acts of God, or use of products not approved by KOOLMORE Appliances
5. Any food loss due to product failure.
6. Repairs to parts or systems resulting from unauthorized modifications made to the appliance.
7. Replacement parts or repair labor costs for units operated outside the United States or Canada.
8. Travel or transportation expenses for customers who reside in remote areas.

The warranty does NOT apply for:

1. Damages due to chipping, peeling of coating and denting.
2. Breakage or damage to components made of Bakelite, plastic materials, rubber parts and cord.
3. Normal wear and tear of parts; Normal Product Maintenance and Cleaning
4. Damage resulting from accident, mishandling or negligence on the part of the customer. Liability for consequential loss or damage is neither accepted nor implied.
5. General rebuilding or refurbishing that is not a legitimate warranty repair. Failures caused by:
6. Unauthorized service.
7. Grease or other material buildup due to improper.
8. Cleaning or maintenance.
9. Accidental or intentional damage.
10. Connection to an improper gas or power supply.
11. Use of improper pans, containers, or accessories that cause damage to the product.

This warranty is valid only when:

1. This appliance has not been opened or tampered with by any unauthorized person.
2. The appliance is brought to and taken from the retailer at the customer's cost and risk.
3. The warranty card and Cash Memo duly signed by the authorized retailer are present with the complaint.
4. The appliance has been installed, used and maintained in accordance with the instruction manual.

Warranty is void if:

1. Serial plate is defaced.
2. Product is altered by user
3. Product is not installed or used according to manufacturer's instructions

For warranty or repair service: Email us at support@koolmore.com include your name, address, phone number, warranty repair request, and a copy of your proof of purchase receipt. You can also visit us at koolmore.com and use the contact us page.

KOOLMORE customer service will contact you and arrange prompt service for your appliance.

