

GoWISEUSA®

ELECTRIC 4-IN-1 MEAT GRINDER & FOOD PROCESSOR

USER MANUAL

Model No.: GW88010



Please read through this manual carefully before use

 **IMPORTANT SAFEGUARDS AND TIPS**

WWW.GOWISEUSA.COM

THANK YOU FOR YOUR PURCHASE!

Join

the GoWISE Community on Facebook, Instagram, Twitter, and Pinterest for updates, tips, and great deals!



Explore

recipes on our recipe App or www.gowiseproducts.com/blogs/recipes



Contact Our Customer Care Team

855-233-9199

support@gowiseusa.com

Live Chat at gowiseusa.com

M-F 8:30am - 4:00pm MST



Register Your Product

www.gowiseproducts.com/apps/product-registration

(The serial number is normally underneath the product. Please check there first.)



Specifications

Voltage: 120V, 60Hz

Wattage: 300W

Max. Locked Motor approx.
wattage: 800W

Overall Dimension (LxDxH):
10"x5.7"x12.1"



TABLE OF CONTENTS

Register Your Product.....	2
Specifications.....	2
Important Safeguards.....	4
Product Structure.....	6
Set Up & Instruction.....	8
Before First Use.....	8
Assembling.....	8
Mincing Meat.....	10
Reverse Function.....	10
Making Sausage.....	11
Making Kibbe.....	12
Vegetable Attachments.....	13
Cleaning & Maintenance.....	14
Warranty.....	16

IMPORTANT SAFEGUARDS

HOUSEHOLD USE ONLY • READ ALL INSTRUCTIONS BEFORE USE

- 1. READ THE ENTIRE MANUAL BEFORE ATTEMPTING TO OPERATE.**
2. Keep the box and packing material for storage.
3. This appliance is intended for household use only. **DO NOT** use for commercial purposes. Using the appliance for commercial purposes will void the warranty.
4. **ALWAYS** make sure there is no power to the unit when assembling or disassembling the unit. **DO NOT** attempt to assemble or disassemble the unit when it is plugged in.
5. This appliance is **NOT INTENDED FOR USE** by persons (including children) with reduced physical, sensory or mental capabilities, or lack of experience and knowledge, unless they have been given supervision or instruction concerning use of the appliance by a person responsible for their safety.
6. This appliance is **NOT INTENDED FOR USE** by children. Children should be supervised to ensure that they **DO NOT** play with the appliance.
7. Close supervision is necessary when any appliance is used near children.
8. When carrying the unit be sure to hold the body with both hands. **DO NOT** carry the unit by the hopper plate or head.
9. **DO NOT** use the cutting blade and cutting plate when using kibbe attachment.
10. To avoid injury, **NEVER** push ingredients by hand. **ALWAYS** use the food pusher to push ingredients into the grinder.
11. **DO NOT** grind hard food such as bones, nuts, etc. This may damage the grinding gears.
12. **DO NOT** grind ginger and other materials with hard fiber. This may damage the grinding gears.
13. The unit should not run for more than 10 minutes continuously. If the meat grinder is needed for more than 10 minutes, it must be turned off to cool down the motor for 10 minutes.
14. Operate the unit from "ON" to "R" or from "R" to "ON" after the previous working condition stops for more than 30 seconds, or it may cause some abnormal movements such as moving up and down that will easily destroy the unit.
15. To avoid jamming, **DO NOT** force or operate the unit with excessive pressure.

IMPORTANT SAFEGUARDS

HOUSEHOLD USE ONLY • READ ALL INSTRUCTIONS BEFORE USE

16. When the circuit breaker activates, **DO NOT** turn the unit on.
17. **NEVER** try to replace the parts and repair the unit by yourself. Please contact GoWISE Customer Care Team via email support@gowiseusa.com or phone 1-855-233-9199.
18. **DO NOT** operate this appliance if the cord or plug is damaged. Please contact GoWISE Customer Care Team via email support@gowiseusa.com or phone 1-855-233-9199.

**SAVE THESE
INSTRUCTIONS**

PRODUCT STRUCTURE

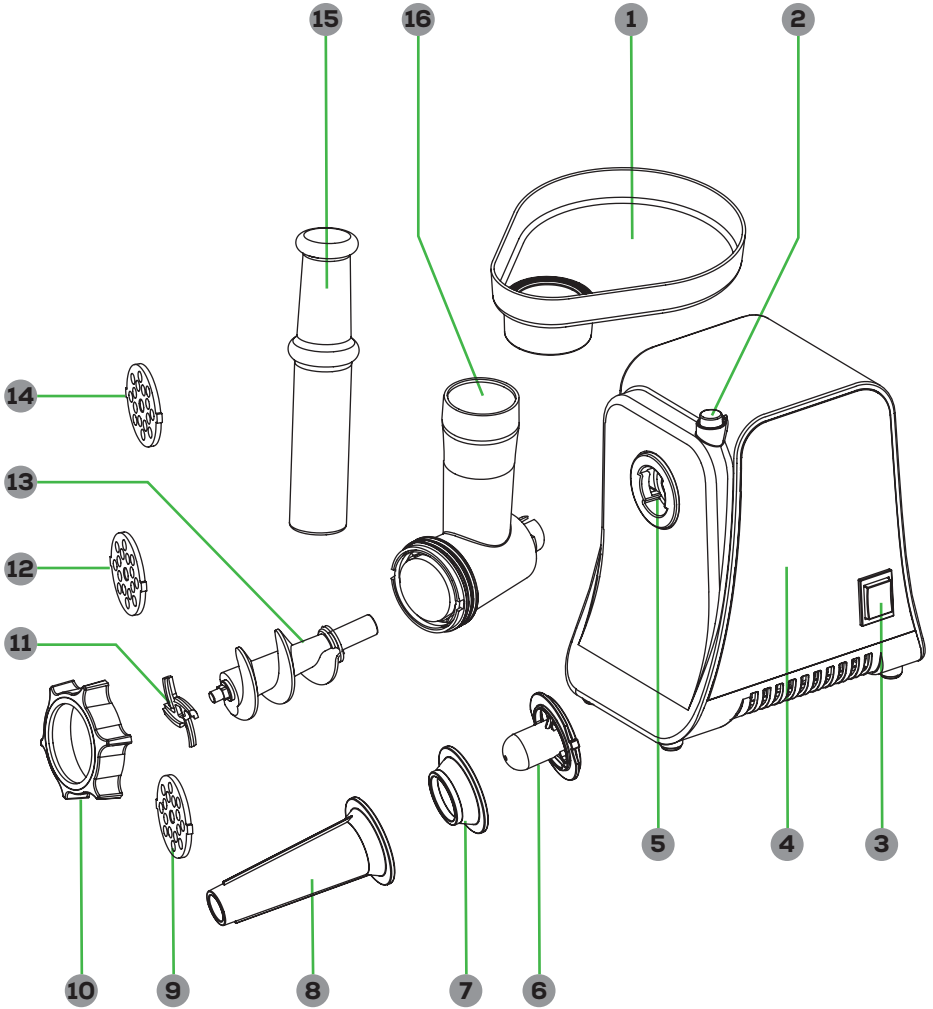

SET UP & INSTRUCTION

BEFORE FIRST USE

1. Remove all packaging materials, stickers, and labels.
2. Check that voltage indicated on the rating label corresponds the mains voltage in your home.
3. Wash all parts (except body) in warm soapy water.
4. Before plugging in the unit, ensure the ON/OFF/R switch is in "OFF" (O) position.

ASSEMBLING

1. Press the lock button, hold the grinding head and insert it into the head inlet (when inserting, pay attention to the head inlet, the grinding head must be slanted as per arrow indicated on the top, see fig. 1), then move the grinding head counterclockwise to fasten the grinding head to the head inlet. The grinding head should be locked when it is properly fastened into the head inlet (fig. 2).
2. Place the snake into the grinding head, long end first and turn to feed the screw slightly until it is set into the motor housing (fig. 3).
3. Place the cutting blade onto the snake shaft with the blade facing the front as illustrated (fig. 4). If it is not fitted properly, the meat will not be grinded.

**CAUTION: SHARP BLADES.
HANDLE WITH CARE.**

4. Place the desired cutting plate next to the cutting blade, fitting protrusions into the slots (fig. 5).
5. Support or press the center of the cutting plate with one finger then screw the fixing ring tight with another hand (fig. 6).
DO NOT OVER TIGHTEN.
6. Place the hopper plate on the grinding head and place it into position (fig. 7).
7. Place the unit on a flat and stable surface.

NOTE: The air passage at the bottom and the side of the motor housing should be kept free and not blocked.

SET UP & INSTRUCTION

ASSEMBLING

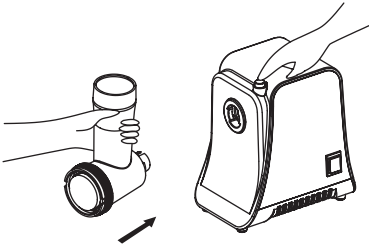

Figure 1.

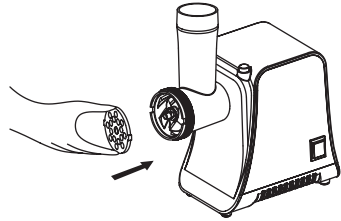

Figure 5.

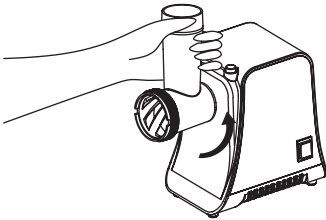

Figure 2.

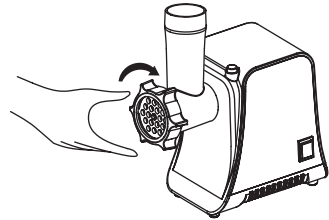

Figure 6.

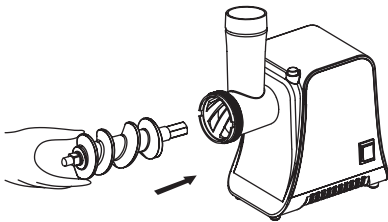

Figure 3.



Figure 7.

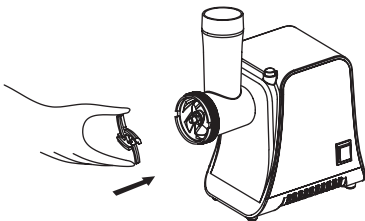

Figure 4.

SET UP & INSTRUCTION

MINCING MEAT

1. Cut all ingredients into small sized strips or cubes (no tendons, boneless and fatless meat is recommended) so that they fit easily into the hopper opening.
2. Plug the unit on and press R/O/ ON switch to the "ON" position.
3. Feed ingredients into the hopper plate. Use the food pusher to push the ingredients into the grinding head (fig. 8).

CAUTION: DO NOT USE YOUR HANDS TO PUSH FOOD INTO THE GRINDING HEAD.

4. Always switch the unit off and unplug it from the power supply when the unit is not in use.

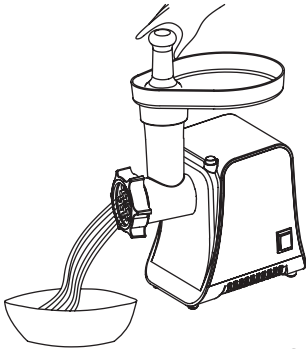

Figure 8.

REVERSE FUNCTION

1. If the grinder jams during the grinding process, first switch off the appliance by pressing R/O/ ON switch to "O" (OFF) position, then press to "R" position.
2. The snake will be rotate in the opposite direction, and the head will get empty.
3. Once the jam looks clear, press the R/O/ON switch to the "O" (OFF) position first then press "ON" to continue grinding.
NOTE: If it continues to jam or the reverse function does not work, turn the unit off and unplug the unit.
4. Clean the parts by taking the rings and snake apart.

SET UP & INSTRUCTION

MAKING SAUSAGE

Preparation

You will need sausage casings for making sausages. Be sure to purchase sausage casings at your local grocery store or butcher.

Prepare the sausage casing as instructed on the package or by your butcher. Most sausage casings require soaking in water for at least an hour.

While the sausage casings are soaking, mince the meats you intend to stuff into sausages. Mix and season together in a bowl.

1. Before starting, assemble the sausage attachment as per shown in the diagram below (fig. 9).
2. Thread the sausage casing to the sausage attachment (fig. 10).
NOTE: Keep the sausage casing as wet as possible to make it easier to thread onto the sausage attachment.
3. Once threaded, load the hopper with the sausage meat and press the R/O/ON switch to "ON" until you see a bit of meat come through the sausage attachment then turn off the unit.
4. Pull a bit of the sausage casing out and tie the end in a knot. Thread the sausage casing with the knot at the end of the sausage attachment. This will ensure a tight connection.
5. Press R/O/ON switch to "ON" to turn on the unit and feed meat into the grinding head using the food pusher.
6. While the food is pushing out, hold the sausage links up to guide the sausage out to ensure the stuffing is as tight as possible.
7. Once all the meat has been pushed out, cut the end of the sausage casings.
NOTE: Be sure to cut with a bit of extra casing at the end.
8. Roll into sausages into a coil or separate into sausage links.

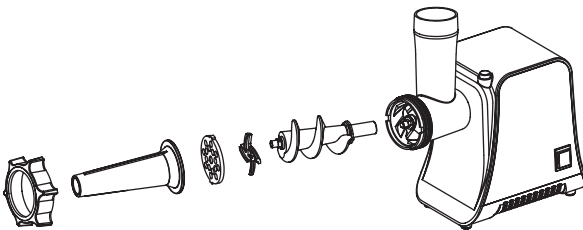

Figure 9.

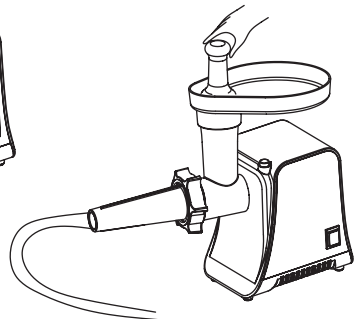

Figure 10.

SET UP & INSTRUCTION

MAKING KIBBE

Kibbe is a dish popular in Middle Eastern cuisine. It is usually spiced ground meat with a grain. (See recipe book for a Kibbe recipe).

1. Once the meat has been minced properly, disassemble by reversing the steps from Figure 6-3 (pg. 9) to remove the cutting plate and cutting blade.
2. Place kibbe attachments A and B onto the feed screw shaft together, fitting protrusions in the slots (fig. 11).
3. Screw fixing ring into place until tight (fig. 12). DO NOT OVER TIGHTEN.
4. Press R/O/ON switch to "ON" to turn on the unit and meat will start to come out of the kibbe attachment.

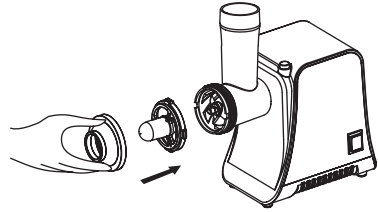

Figure 11.

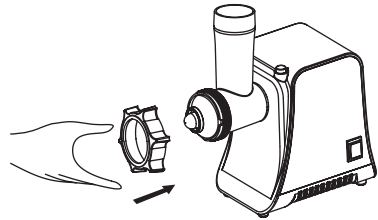

Figure 12.

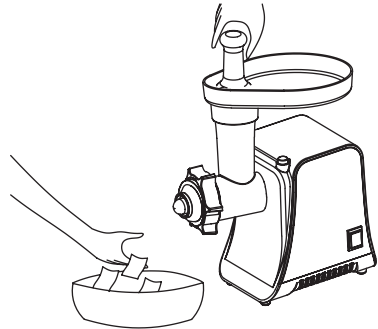

Figure 13.

SET UP & INSTRUCTION

ASSEMBLING THE VEGETABLE SLICER

1. Place the unit on a flat and even surface.
 2. Press the lock button and hold the vegetable shredding head and insert it into the inlet at an angle (fig. 14).
 3. Turn the vegetable shredding head counterclockwise to fasten the head into place (fig. 15).
 4. Insert the desired grating or shredding cone (fig. 16).
 5. Fasten the shredding fixing ring to keep the cone in place (fig. 17).
 6. Press the ON/O/R switch to the "ON" position to turn on the grinder.
 7. Feed vegetable into the shredding head and push it down using the shredding pusher (fig. 18).
- CAUTION: DO NOT USE YOUR HANDS TO PUSH FOOD INTO THE SHREDDING HEAD.**
8. Once all ingredients have been shredded, press the ON/O/R switch to the "O" position to turn off the grinder. Unplug the unit.

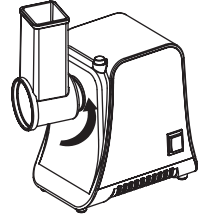

Figure 15.

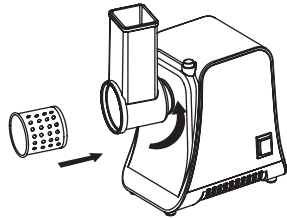

Figure 16.

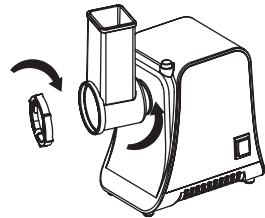

Figure 17.

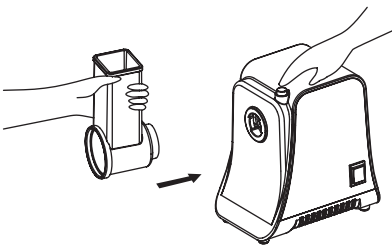

Figure 14.

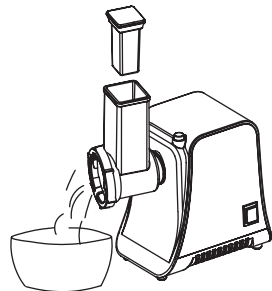

Figure 18.

CLEANING & MAINTENANCE

DISASSEMBLING

1. Make sure that the motor has turned off completely.
2. Unplug the unit from the power outlet.
3. Disassemble the unit by reversing the steps from Figure 1-6 on Page 9.
4. To remove the cutting plate easily, place a screwdriver between the cutting plate and the head as illustrated and lift it up (fig. 19).
5. Press the lock button, move the head clockwise as illustrated on fig. 20, then you can take out the head.

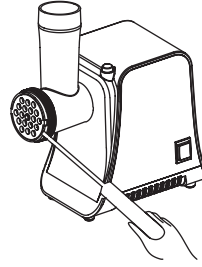

Figure 19.



Figure 20.

CLEANING & MAINTENANCE

CLEANING

- 1.** Remove meat, etc. Wash each part in warm soapy water.
- 2.** Wipe all the cutting parts with vegetable oil-wet cloth.
- 3. DO NOT** immerse the motor housing in water, but only wipe it with a damp cloth.

NOTES:

- The removable parts are NOT dishwasher safe.
- Coat cutting parts with oil, such as olive oil or vegetable oil, to prevent rusting.
- A bleaching solution containing chlorine will discolor aluminum surfaces.
- Thinners and petrol will crack or change the color of the unit.

To order replacement parts please contact our Customer Care Team.

855-233-9199

support@gowiseusa.com

Live Chat at gowiseusa.com

M-F 8:30am - 4:00pm MST

WARRANTY

GoWISE USA warrants all products against defects in materials and workmanship for **one (1) year** effective from the date of purchase.

GoWISE USA will replace any products that are found to be defective due to manufacturer flaws based on eligibility. Refunds issued by GoWISE USA must be purchased directly from GoWISE USA and are only available to the original purchaser within the first 30 days. We do not issue refunds for items bought by thirdparty retailers.

This warranty extends only to personal use and does not extend to products that has been used for commercial, rental or any other use this product was not intended for. There are no warranties other than the warranties expressly set forth with each product.

This warranty is non-transferrable. GoWISE USA is not responsible in any way for any damages, losses, or inconveniences caused by equipment failure by user negligence, abuse, or use noncompliant with the user manual or any additional safety, use, or warnings included in the product packaging and manual.

This warranty only covers purchases within the 48 contiguous states of United States of America. For purchases made outside the 48 contiguous states, such as AK, HI, PR, or Canada, we will replace the unit under the one-year warranty upon receipt of a proven defect by video or picture. However, the replacement will only ship to a freight forwarder or address within the 48 contiguous United States. The consumer is responsible for arranging shipment outside of the 48 contiguous states.

GoWISE USA assumes no liability for damage caused using this product other than for its intended use or as instructed in the user manual. Some states do not allow this exclusion or limitation of incidental or consequential losses, so the foregoing disclaimer may not apply to you. This warranty gives you specific legal rights and you may also have other rights which may vary from state to state.

ALL EXPRESSED AND IMPLIED WARRANTIES INCLUDING THE WARRANTY OF MERCHANTABILITY, ARE LIMITED TO THE PERIOD OF THE LIMITED WARRANTY.

NOTE: General Warranty excludes refurbished / auction items.

WARRANTY

Additional 60-Days Warranty

You can extend your 1-year warranty by an additional 60 days. Log onto [www.gowiseproducts.com/apps/ product-registration](http://www.gowiseproducts.com/apps/product-registration) and register your product within the first 14 days of your purchase for the extended warranty.

DEFECTIVE PRODUCTS & RETURNS

If your product is defective within the 1-year warranty period, please email our Customer Care Team at support@gowiseusa.com. To expedite your issue, please provide the 4 items below:

1. Copy of the invoice, order information, or gift receipt showing the date of purchase
2. Serial number, usually found on a sticker located on the bottom on back of the unit
3. Picture or video of the issue or defect that you are experiencing
4. Shipping address information

Authorized Retailers:

Amazon

GoWISE USA

WayFair

Houzz

Home Depot

etailz

MorningSave.com

Bed Bath & Beyond

Jet.com

Walmart.com

Macy's

GoWISEUSA®

WWW.GOWISEUSA.COM

855-233-9199

support@gowiseusa.com

Live Chat at gowiseusa.com

M-F 8:30am - 4:00pm MST

- To ensure the correct use of this appliance, read these instructions carefully and thoroughly.
- Please keep this manual for future reference.
- Thank you for purchasing this GoWISE USA Electric Meat Grinder & Food Processor.

USE PROMO CODE: **LIVewisERAF**

10%
OFF

YOUR NEXT **GoWISEUSA®** PURCHASE

