

Wire Shelving

ASSEMBLY INSTRUCTIONS

CAUTION

INSPECT CONTENTS IMMEDIATELY AND FILE CLAIM WITH DELIVERING CARRIER FOR ANY DAMAGE. **SAVE YOUR BOX AND ALL PACKING MATERIALS.** YOU ARE RESPONSIBLE FOR DAMAGE TO YOUR UNIT IF RETURNED IMPROPERLY PACKED.

BEFORE ASSEMBLY, PLEASE READ:

Helpful Suggestions:

- Shelves up to 48" in length can support an evenly distributed static load of 800 lbs.
- Shelves of 54", 60", and 72" length can support an evenly distributed static load of 600 lbs.
- **IMPORTANT:** Shelving units should not exceed 2400 lbs. per set of four posts.
- Large installations are easier if all posts are marked first. Lay posts on floor with leveling bolts against a wall or straight edge. Mark all posts using a magic marker or grease pencil.

For Best Performance:

- Units over 50" high should be assembled with no less than 3 shelves—preferably 4 or more—and the bottom shelf should be placed as low as possible or practical.
- On mobile units with 18"-wide shelves, the overall post height should be no greater than 74".
- On mobile units with 24"-wide shelves, the overall post height should be no greater than 86".

FOR STARTER UNITS:

(For Mobile Units, see back page on how to install casters **BEFORE** assembling unit.)

Step 1 - Attach split sleeves (for bottom shelf) to posts.

- The wider part of the taper goes toward the bottom.
- Make sure rib on split sleeve is seated into a groove on the post.

Note: The number covered by the split sleeve indicates approximate height of shelf.

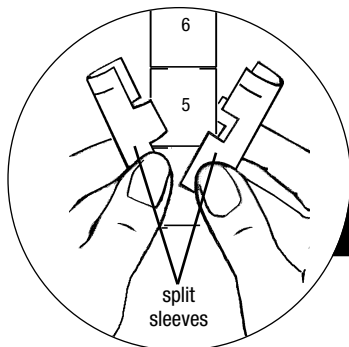

Step 2 - Mount bottom shelf.

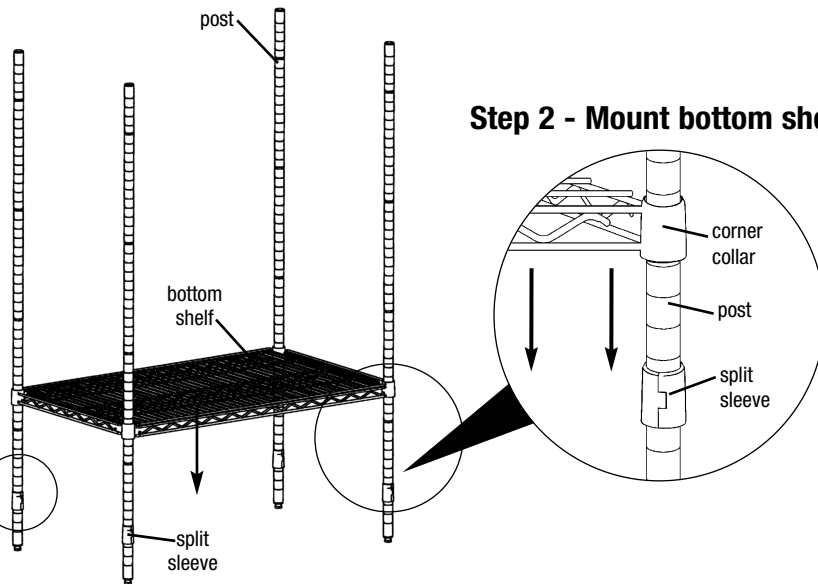

Note: If using aluminum split sleeves, set aside retaining rings until later.

EAGLE wire shelving must be cleaned with soft cloths and mild detergents. Using harsh detergents, abrasive materials, scrapers or stiff brushes will void the warranty, as will physical damage, rupturing the coating or sustained exposure to corrosive substances and vapors.

(continued on page 2)

EG9826 Revised 02/24



- 100 Industrial Boulevard, Clayton, Delaware 19938-8903 U.S.A.
- Phone: 302/653-3000 • 800/441-8440 • Fax: 302/653-2065
- www.eaglegrp.com • www.eaglehmc.com

Wire Shelving

ASSEMBLY INSTRUCTIONS

FOR STARTER UNITS (continued):

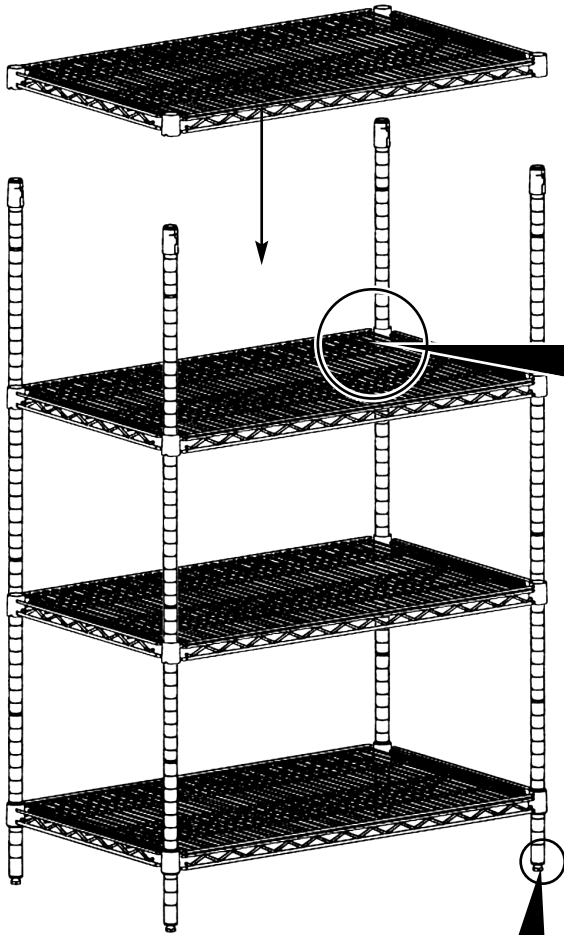

Step 3: Mount additional shelves.

Refer to Steps 1 & 2 (front page), working from bottom to top.

Step 4: Securely seat all shelves.

Note: Do NOT hammer directly on wire or corner.

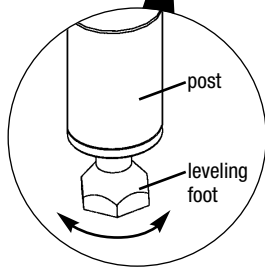
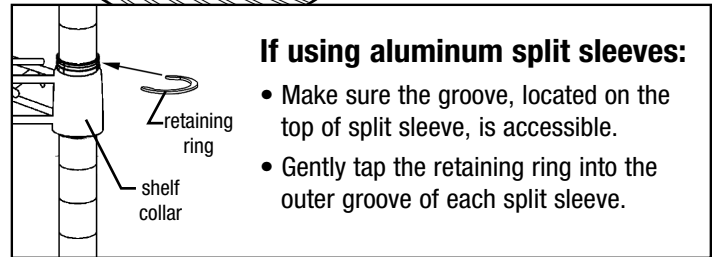
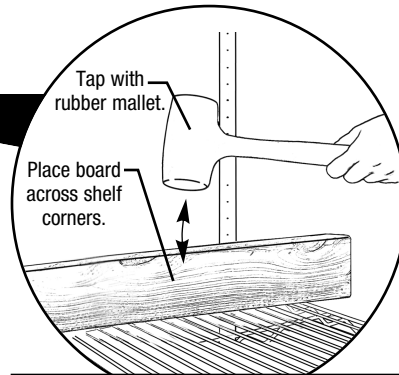

Step 5: Level unit.

The leveling bolts allow approximately 1/2" adjustment.

(End)

WARNING – TIPPING HAZARD

- Use caution when moving heavily loaded carts. Heavy loads are hard to control.
- Do not step, stand or climb on shelving units.
- Place heavy objects on lowest shelf.

Failure to follow these guidelines can result in property damage or personal injury.

For Add-On Units, see page 3. For Mobile Units, see back page.

EAGLE wire shelving must be cleaned with soft cloths and mild detergents. Using harsh detergents, abrasive materials, scrapers or stiff brushes will void the warranty, as will physical damage, rupturing the coating or sustained exposure to corrosive substances and vapors.

Wire Shelving

ASSEMBLY INSTRUCTIONS

FOR ADD-ON UNITS:

Step 1: Mount split sleeves and shelves.

Refer to Steps 1 & 2 (front page), working from bottom to top.

IMPORTANT: Add-on unit must have shelves at the same height as the unit to which it will be attached.

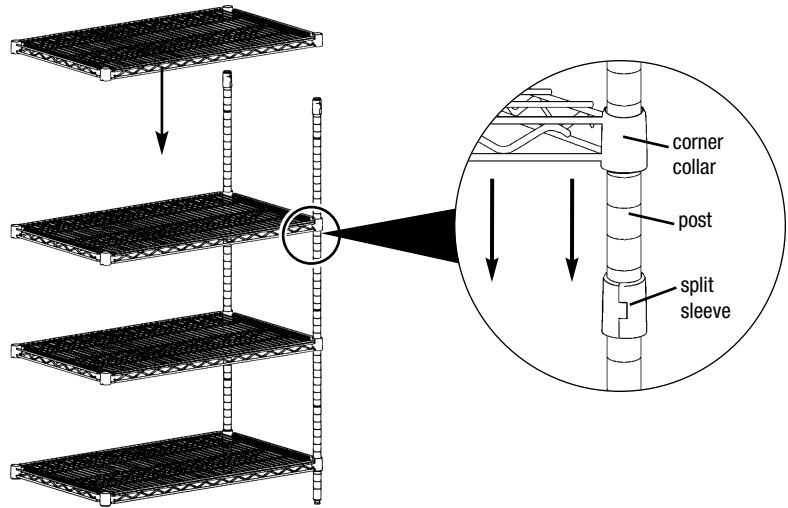

Step 2: Connect add-on unit to starter unit.

NOTE: "S" hooks should be placed as close to a post as possible.

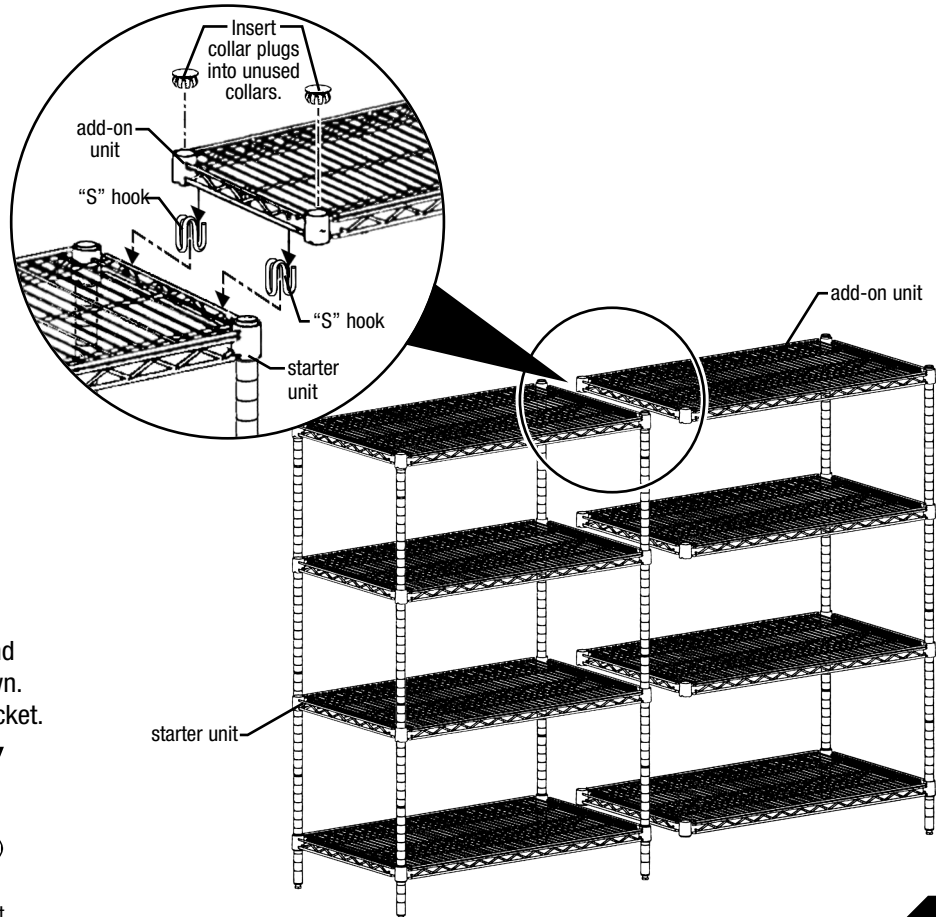

For units with Security S-Hooks, refer to Step 3 below...

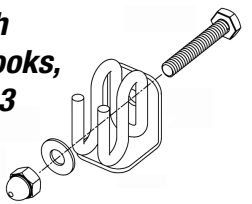

Step 3 - Attach hardware.

- Position latch next to s-hook as shown.
- Run bolt through latch, s-hook, shelves and washer, and screw into acorn nut as shown.
- Tighten hardware with 7/16" wrench or socket.

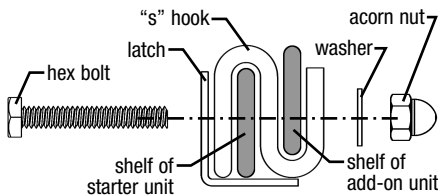

(FRONT VIEW OF SHELF UNITS)

(End)

For Mobile Units, see back page.

EAGLE wire shelving must be cleaned with soft cloths and mild detergents. Using harsh detergents, abrasive materials, scrapers or stiff brushes will void the warranty, as will physical damage, rupturing the coating or sustained exposure to corrosive substances and vapors.

Wire Shelving

ASSEMBLY INSTRUCTIONS

FOR MOBILE UNITS:

Step 1 - Place donut bumpers onto bottom end of post.

Bottom is end with hole for caster stem.

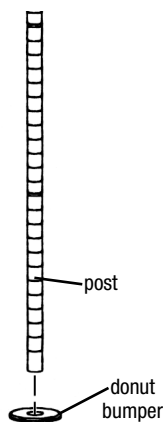

Step 2 (for rigid casters only. Otherwise, proceed to Step 3) - Place alignment channel onto stems of rigid casters.

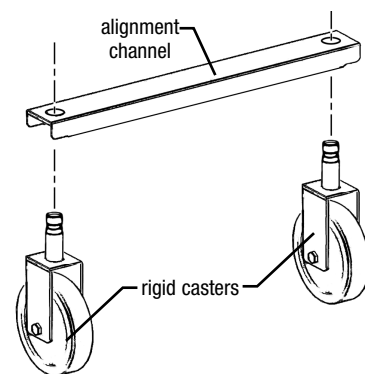

Step 3 - Drive in caster using a hammer or mallet.

Several solid blows are usually required.

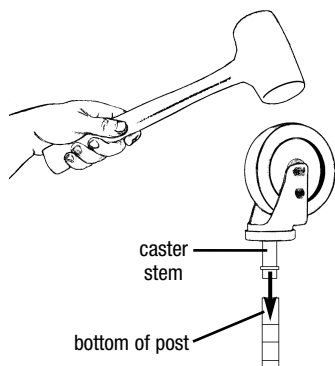

Step 4 - Mount shelves.

Refer to Steps 1 & 2 (front page), working from bottom to top.

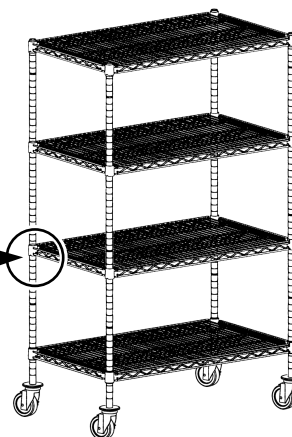
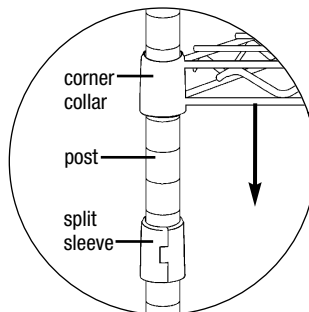

(End)

Notes about Mobile Units:

- **IMPORTANT:** Mobile units should not exceed 1000 lbs. per set of four posts.
- First shelf should be located at bottom groove for most stability.
- Overall height should not exceed 74".
- Do not construct carts with shelves less than 18" wide.
- Inspect and maintain casters regularly. Replace casters that are damaged or severely worn.



WARNING – TIPPING HAZARD



- Push mobile units in long direction.
- Use caution when moving heavily loaded carts. Heavy loads are hard to control.
- Do not step, stand or climb on shelving units.
- Place heavy objects on lowest shelf.
- Inspect casters before use.
- Replace casters that are worn immediately.

Failure to follow these guidelines can result in property damage or personal injury.

EAGLE wire shelving must be cleaned with soft cloths and mild detergents. Using harsh detergents, abrasive materials, scrapers or stiff brushes will void the warranty, as will physical damage, rupturing the coating or sustained exposure to corrosive substances and vapors.



- 100 Industrial Boulevard, Clayton, Delaware 19938-8903 U.S.A.
- Phone: 302/653-3000 • 800/441-8440 • Fax: 302/653-2065
- www.eaglegrp.com • www.eaglehmc.com