



## Mobile Data Terminal

### P400 Quick Start Guide

Need Support?  
Issue with missing or damaged items?  
✉ info@tera-digital.com  
🌐 https://www.tera-digital.com  
☎ +1(626)438-1404

### About the Terminal

Introducing the Tera P400: An advanced rugged handheld computer designed to deliver exceptional performance in demanding environments. Powered by the Android™ 11 operating system and equipped with a Mediatek Octa-Core processor, the P400 offers a seamless user experience.

This innovative device offers versatile input options, including both numeric and alphabetic keypads, providing flexibility for various use cases.

One standout feature is the potent and easily replaceable battery, providing extended usage time and reducing downtime. Moreover, the P400 boasts functionalities like barcode scanning, NFC, and more. This broad spectrum of capabilities makes it an ideal solution for applications spanning logistics, warehousing, retail, and beyond.

### Terminal Features

The front, back and side view of the P400 are shown as follows:

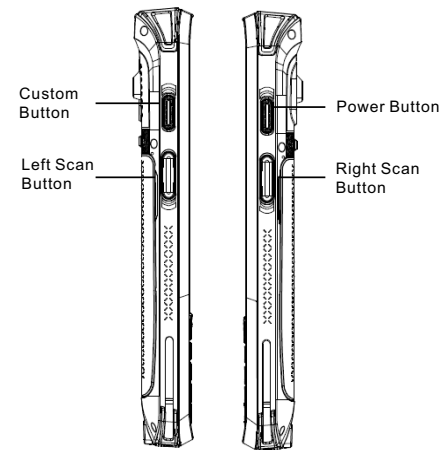
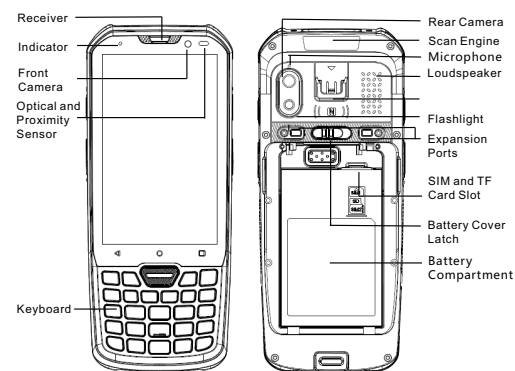

### Buttons and Description

The P400 features a keypad comprising numeric keys and functional keys.

Buttons	Description
Power Button	Press and release the Power Button to turn on/off the terminal screen. Press and hold the button for approximately 3 seconds, and then release to view the options menu. • Power Off • Restart • Emergency
Scan Button	Press the right or left Scan Button or the one on the keypad to trigger the scanner.

### Restart the terminal

You may need to restart the terminal to correct conditions where an application stops responding to the system or the terminal seems to be locked up.

1. Press and hold the Power button until the options menu appears.
2. Select Restart.

To restart the terminal if the touch panel display is unresponsive: Press and hold the Power button for approximately 8 seconds until it restarts.

### Install Micro SD and SIM cards

The positions of the card slots are indicated as follows:

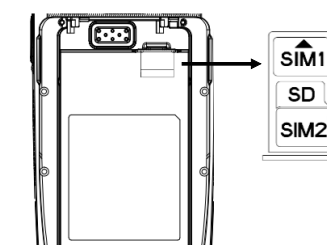

Note: Always power off the terminal before attempting to install or remove a card.

### About the Battery

The terminal uses a rechargeable Li-ion battery as its main power source. Several factors determine the life of the battery, such as screen brightness, screen timeout, network option, and extreme temperature.

1. If you are storing the terminal for a few days (such as cover the weekend), install a fully charged battery or connect the terminal to a power source. If you are storing the terminal for a longer period of time, remove and charge the battery. When the battery is done charging, store both the battery and the terminal in a cool location. If you store the battery for several months, recharge the battery periodically to keep it at peak performance.
2. Expected Battery Life: Under typical conditions, the battery

can retain up to 80% of its original capacity after approximately 300 complete charge cycles. A charge cycle involves the process of both charging and discharging the battery as needed for device usage.

3. As lithium-ion batteries chemically age, the amount of charge they can hold diminishes, resulting in shorter amounts of time before a device needs to be recharged.

4. For maximum battery life, charge the battery at 20 °C (68°F) to 25°C (77°F) and store at 20°C (68°F) with a 30%-50% charge.

**Caution:** Improper battery replacement or incompatible device usage may result in risk of burns, fire, explosion, or other hazard. Dispose of lithium-ion batteries according to local regulations. Risk of fire and burns if improperly handled. Do not open, crush, heat or incinerate.

### Install the Battery

1. Insert the charged battery pack into the battery compartment. The bottom of the battery must go in first.
2. Press the battery down into the battery compartment until the battery release latches snap into place.
3. Slide the battery latch to the left.

### Remove the Battery

1. Press and hold the Power button until the options menu appears.
2. Tap Power off.
3. Slide the battery latch to the right. The battery ejects slightly.
4. Remove the battery from the battery compartment.

### Charge the Terminal

This device comes with a USB Type-C port, and it is recommended to charge the device using the provided original USB cable and power adapter. Begin by connecting the USB cable to the power adapter, and then connect it to the terminal.

The terminal will start charging automatically, and the LED Indicator will display the current charge status. If the LED indicator is solid red, it means that the terminal is charging; if the LED indicator is solid green, it indicates that the terminal is fully charged.

You also have the option of using the original USB Type-A to USB Type-C cable to charge the terminal from a host device, such as a laptop or desktop computer. However, please ensure that the connected host device can supply a minimum power output of 5V and 0.5A to the terminal.

Using the terminal while charging the battery increases the time required to reach a full charge. If the mobile terminal is drawing more current than supplied by the charging source, charging will not take place.

(Note: Avoid using third-party cables or adapters to charge the terminal for optimal performance and safety.)

### About Near Field Communication (NFC)

NFC technology provides the ability for short-range, wireless data transfer between the P400 and NFC tags or other NFC enabled devices placed in close proximity to the back of the terminal.

The P400 supports the following mode of operation: NFC tag reader/writer mode. The terminal reads and/or writes digital information from or to an NFC tag.

### About the BCScan Application.

BCScan is a demonstration application designed to test scan performance and manage the scan engine. Please be aware that not all barcode symbologies are activated by default in the BCScan app. If a barcode fails to scan, it is possible that the correct symbology is not enabled.

To modify the scan profile or assess the scan engine's performance, you must launch the BCScan application. Below is a screenshot showcasing the application's primary interface.

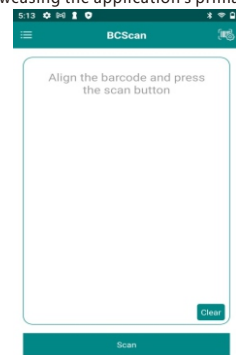

In the Demo app, tap in the upper left corner of the screen to obtain further information regarding each scan result.

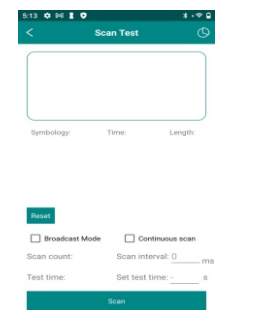

The scan results will appear in the upper box and the related information regarding the scanned barcode including symbology, decoding time and message length will show up in the fields underneath the box.

If you need to check scanning accuracy, please tap .

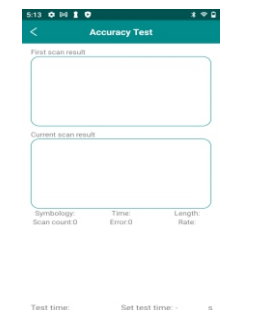

In this screen, you will find two text boxes where will show the previous scan and the current scan so as for the user to identify if the scans are the same.

To set up the scan engine, please tap to access scanner settings

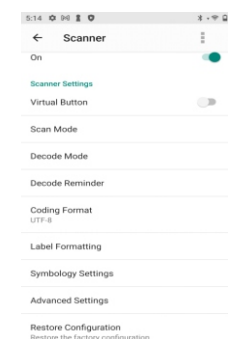

By default, the integrated scan engine is enabled for scanning. It supports omni-directional barcode scanning, and an aiming beam is provided to help assist with targeting barcodes.

If you require data format modifications such as adding a prefix or suffix, or removing characters, please tap on the Label Formatting option to access additional settings. If you need to enable or disable symbologies, DPM Mode, or OCR Mode, please tap on the Symbology Settings option to access further settings.

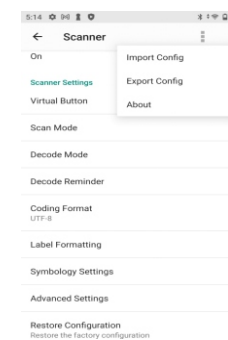

If you have completed the setup process for a device and would like to install the same configuration on another device, please follow these steps:

- Tap , and choose the "Export Config" option
- Locate the exported file and transfer it to the desired device.
- Launch the BCScan app on the target device.
- Navigate to the scanner settings within the app.
- Select the "Import Config" option to load the previously exported file.

### Specifications

#### Mechanical

Dimensions	160.5 x 67 x 17 mm / 6.3 x 2.6 x 0.67 in.
Weight	243 g / 8.57 oz. (battery included)
Display	4-inch 800(H)* 480(W) WVGA IPS
Physical Keyboard	26 keys, Side buttons: 2 SCAN buttons + 1 Power button + 1 User-defined button
Battery	5100 mAh removable li-ion battery Standby: over 300 hours Continuous use: over 12 hours (depending on user environment) Charge time: 3 hours (with the original adaptor and USB cable)
SIM Card Tray	2 slots for Nano SIM card, 1 slot for TF card
Audio	2 microphones, 1 speaker
Camera	5MP autofocus camera; f/2.2 aperture; Flash LED

#### System Architecture

CPU	Mediatek MT6762, 2.0 GHz Octa-core
Operating System	Android 11
RAM	4GB
Interface	USB Type-C
ROM	64GB
Storage Expansion	Micro SD card (up to 256 GB)

#### Environmental

Operating Temperature	-20°C to 50°C / -4°F to 122°F
Storage Temperature	-40°C to 70°C / -40°F to 158°F
Humidity	5%RH - 95%RH (Non-condensing)
Sealing	IP67, IEC sealing standard
Drop Test	Multiple drops to concrete at room temperature from 1.8m / 5.9 ft.
Electrostatic Discharge (ESD)	+/-15 kV air discharge, +/-8 kV direct discharge

#### Connectivity

WAN	2G/3G/4G
WLAN	IEEE 802.11 a/c/a/b/g/n/d/e/h/i/j/s/k/r/n/v w (2.4G/5G Dual band WIFI)
Bluetooth	Bluetooth 5.0, Bluetooth Low Energy (BLE)

#### Data Collection

Scan Engine	Honeywell Scan Engine
NFC	ISO 14443 Type A and B