



Slushie Maker

User Manual



SM 5770

EN



01M-8919953200-3125-01



Please read this manual first!

Dear Customer,

Thank you for choosing a Beko product. We want you to get the most out of this appliance, which has been manufactured with state of the art technology. Please make sure you read and understand this guide and supplementary documentation fully before use and keep it as a reference. If you give the appliance to someone else, give them this user manual as well. Observe all warnings and information in this guide and follow the instructions.

Symbols and their meanings

The following symbols are used throughout this guide:



Important information and useful tips for using the appliance.



WARNING: Warnings about dangerous situations concerning safety of life and property.



Food-grade appliance.



Do not wash the parts in a dishwasher.



This symbol shows that the appliance used a flammable refrigerant.. Risk of fire if the refrigerant leaks and is exposed to an ignition source.

WARNING: Servicing shall only be carried out as specified by the equipment manufacturer. Maintenance and repair work requiring the use of other qualified persons shall only be carried out under the supervision of someone competent in the use of flammable refrigerants. (This rule only applies when the R290 refrigerant is used)

TABLE OF CONTENTS

1 Important Safety and Environmental Instructions	4
1.1 General safety	4
1.2 Compliance with the WEEE Regulation and Waste Disposal	5
1.3 Information on Chemical Legislation ..	5
1.4 Packaging Information	5
2 Slushie Maker	6
3 Operation	10
3.1 Preparation	10
3.2 Use	10
4 Cleaning and Maintenance	13
4.1 Automatic Cleaning Mode	13
4.2 Cleaning and Maintenance	13
4.3 Storage	15
4.4 Transportation and Handling	15
4.5 Important points for energy saving..	15
5 Troubleshooting	16

1 Important Safety and Environmental Instructions

Please read this instruction manual thoroughly prior to using this appliance! Follow all safety instructions in order to avoid damage due to improper use!

Keep the user manual for future reference. If you give the appliance to a third party, please also deliver the user manual.

1.1 General safety

- Read all the instructions.
- Before using the appliance, make sure that the voltage and power match the values on the appliance's rating plate.
- Remove all packaging and bags before using the appliance.
- Never leave the appliance unattended during use.
- Before using the appliance, make sure it has been thoroughly cleaned.
- Do not use the appliance for anything other than its intended use. The appliance is not suitable for commercial use, only household use. Do not use the appliance outdoors.
- To prevent electric shock, never immerse the cord, plugs, motor or electrical parts in water or other liquids.
- Do not use the appliance if the cord or plug are damaged. Do not turn the appliance on if it breaks down or is damaged. In the event of breakdown or damage, take the appliance to the nearest service centre to be examined, repaired or adjusted.
- If the power cord is damaged, it must be replaced by the manufacturer, its service agent, or similarly qualified persons.
- Do not place the appliance on or near hot equipment such as a gas or electric hob or oven.
- To avoid the risk of fire, electric shock or injury, do not use accessories not recommended or sold by the manufacturer.
- Do not let the power cord touch hot surfaces, or hang over the edge of the table or worktop.
- This appliance is not suitable for use by the following persons, including children, without adult supervision or being given the necessary instructions. - Persons with reduced physical, sensory or mental capabilities - Persons lacking experience and knowledge
- Supervise children at all times to stop them playing with the appliance.
- Avoid contact with the moving parts.
- Make sure to unplug the appliance before moving it, cleaning it, storing it, or when not in use.
- Always use this appliance on a sound, stable surface.
- Improper use of the appliance may result in property damage or even physical injury.
- Never use coarse or abrasive cleaners to clean the appliance.
- Always keep the appliance upright. If the appliance is on its side or upside down, turn it upright and wait 24 hours before using it.
- **WARNING:** When placing the appliance, make sure the power cord is not pinched or damaged.
- **WARNING:** Do not place multiple portable plug sockets or portable power sources behind the appliance.
- Operate the appliance on a level surface and do not tilt the appliance when it is working.
- Keep the back and sides of the appliance clear so the compressor can work properly and avoid overheating.
- **WARNING:** Make sure the ventilation holes in the appliance's body or inside are not blocked.
- **WARNING:** Do not use mechanical devices or other methods apart from those recommended by the manufacturer to speed up defrosting.
- To avoid damage to the compressor, do not turn the compressor on frequently. Wait at least 5 minutes before each operation.
- To avoid fire or short circuits, do not insert metal plates or other conductive materials into the appliance.
- Never operate the appliance by means of an external timer or separate remote control system.
- Dispose of used refrigerant in accordance with local regulations.
- Do not move or set up the appliance roughly or by using force. Otherwise, the refrigerant pipes could become damaged and leak.
- Parts such as the compressor, condenser, motor and copper pipes must be replaced with suitable

1 Important Safety and Environmental Instructions

parts. Have care and maintenance carried out by the authorised service to avoid the risk of fire due to incorrect parts or repair.

- **WARNING:** Do not damage the refrigerant circuit.
- Do not put aerosol cans containing combustible gas or similar explosive materials inside the appliance.
- Never put flammable, explosive, or chemically corrosive substances inside the appliance.
- If there is a combustible gas leak, do not use the appliance.
- To avoid a possible fire, never place or use gas or other flammable substances near the appliance.
- To avoid causing a fire or explosion, do not clean the appliance with flammable liquids.
- Do not electric tools in the appliance's food storage compartments as long unless the manufacturer recommends it.
- **WARNING:** Only fill with potable water.
- The following person may use the appliance only with adult supervision or after receiving the necessary instructions. - Children aged 8 years or older - people with reduced physical, sensory or mental capabilities - Persons lacking experience and knowledge Never let children play with the appliance. Unsupervised children must not perform cleaning or maintenance.
- Regularly clean the accessible drainage systems and those surfaces that come into contact with food.
- Clean the water tanks if they haven't been used for 48 hours.
- The appliance is suitable for use at home and in the following places:
 - The staff kitchens of stores, offices and other working environments
 - Farmhouses and hotels, motels, B&Bs and similar accommodations.
 - Places like room breakfast bars
 - Meal service and similar non-retail practices
- Keep these instruction for future reference.

1.2 Compliance with the WEEE Regulation and Waste Disposal



This product complies with EU WEEE Directive (2012/19/EU). This product bears a classification symbol for waste electrical and electronic equipment (WEEE).

This symbol indicates that this product shall not be disposed with other household wastes at the end of its service life. Used device must be returned to official collection point for recycling of electrical and electronic devices. To find these collection systems please contact to your local authorities or retailer where the product was purchased. Each household performs important role in recovering and recycling of old appliance. Appropriate disposal of used appliance helps prevent potential negative consequences for the environment and human health.

1.3 Compliance with RoHS Directive

The product you have purchased complies with EU RoHS Directive (2011/65/EU). It does not contain harmful and prohibited materials specified in the Directive.

1.4 Packaging Information



The appliance's packaging is made of recyclable materials in accordance with the National Legislation. Do not dispose of the packaging waste with the household waste or other wastes, dispose of it in the packaging collection areas specified by local authorities.

2 Slushie Maker

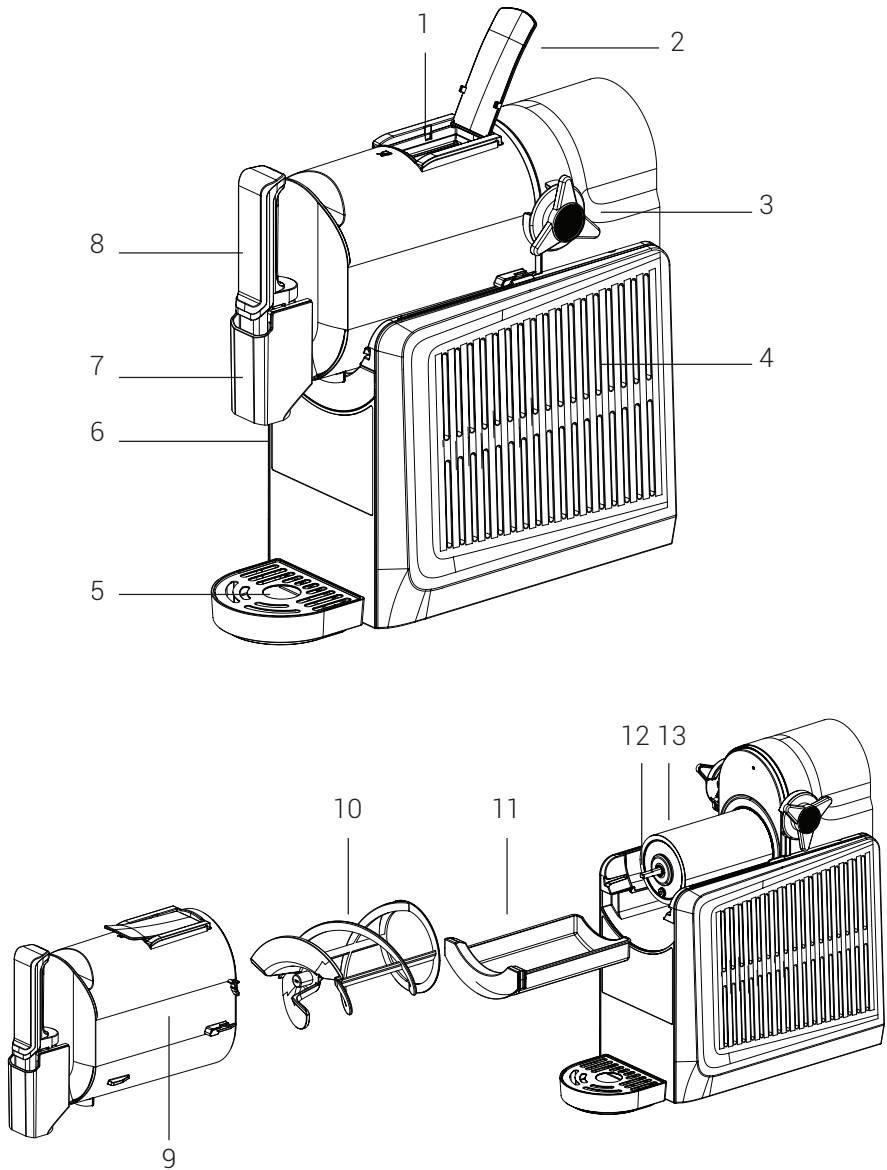

2 Slushie Maker

1. Filler Port
2. Lid
3. Bail Handle
4. Body
5. Drip tray
6. Control panel
7. Spout
8. Dispensing handle
9. Vessel
10. Auger
11. Condensation catch
12. Pin
13. Evaporator

Technical data

Voltage: 220-240 V~, 50 Hz

Power consumption: 170 W

Capacity: 1,8 L

Nominal electric current: 1.3A

Thermal insulation material: Cyclopentane

Refrigerant R290; 23g

Climate type: ST/SN/N

Manufacturer reserves the right to make technical and design changes.

The values provided with the appliance or its accompanying documents are laboratory readings in accordance with the respective standards. These values may differ depending on the use and ambient conditions.

Extra Information for the User Manual:

Technical information for operating in Low Power Modes according to EU Directive 2023/826		
Mode	Power Consumption (Watts)	Duration (Minutes)*
Off	0,5	-
Standby Mode	-	-
Info or status display Standby Mode	-	-
Connected to Network Standby Mode	-	-

The time it takes for the appliance to automatically switch to standby mode, off mode, or network standby mode is measured in minutes and rounded to the nearest whole minute.

2 Slush Maker

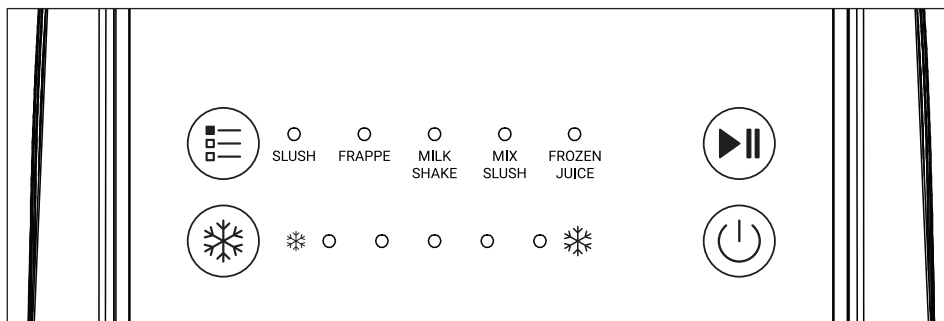

Power Button:

Press the power button to turn on the appliance. The appliance will enter standby mode. Press the power button to turn off the appliance.

Start/Stop Button:

1. Press the Start/Stop button when in standby mode. The appliance will enter operating mode.
2. Press the Start/Stop button when in operating mode. The appliance will exit the current operating mode.

Preset Button:

When in standby mode, press the Preset button to select the preset menu. All preset menus come with recommended temperature settings. The following table gives the recommended temperatures for the preset menus.

Preset Menu	Optimal Temperature Setting
Slush	2
Frappe	3
Milk Shake	3
Mix Slush	3
Frozen Juice	2

2 Slush Maker



Temperature Setting Button

Press the Set Temperature button to select the desired temperature setting. There are five (5) temperature settings to choose from. Increase the temperature setting for thicker and colder slushes.

The following table shows the average temperatures for the drink modes. (°C)

Drink Preset	Temp Preset				
	Temperature 1	Temperature 2	Temperature 3	Temperature 4	Temperature 5
Slush	-1.9 °C	-2.1 °C	-2.2 °C	-2.5 °C	-2.7 °C
Frappe	-1.2 °C	-1.3 °C	-1.4 °C	-1.7 °C	-2.1 °C
Milk Shake	-2.6 °C	-2.8 °C	-3.0 °C	-3.1 °C	-3.2 °C
Mix Slush	-2.5 °C	-4.0 °C	-5.5 °C	-7.0 °C	-8.0 °C
Frozen Juice	-1.8 °C	-1.9 °C	-2.0 °C	-2.3 °C	-2.5 °C

3 Operation

3.1 Preparation

1. Remove all packaging and labelling materials and dispose of them in accordance with the applicable law. Make sure there are no parts missing.
2. Before using the appliance, carefully clean all parts that will come into contact with foods (See 'Cleaning and Maintenance').
3. Do not lean the appliance against the wall. Leave a gap of at least 10 cm.

3.2 Use



- Do not add ice or solid ingredients such as fruit, ice cream, frozen fruit, etc.
- Do not add hot ingredients.



Make sure the mixture is between the MIN and MAX marks on the tank. Pre-chill ingredients to speed up the process.



WARNING: All added ingredients must contain at least 5% sugar.



WARNING: For frothy drinks, we recommend reducing the amount shown below to 1.5 litres. Common frothy drinks: Strawberry juice, coconut milk, lemonade, milk drinks, drinks with artificial sweeteners such as sugar-free cola, etc.

Special Functions and Explanations

Tilt warning

1. If the appliance is tilted more than 60° in any direction, press the Power button. The 1 and 3 temperature setting lights will flash and the appliance will sound at the same time. In addition, all the buttons will be disabled and cannot be operated. If the appliance is tilted less than 60° it will enter standby mode.
2. If the appliance is moved and tilted more than 60° when operating normally, the 1 and 3 temperature setting lights will flash and the appliance will sound at the same time. If the appliance is tilted less than 60° it will continue to operate in the previous operating mode.

3 Operation

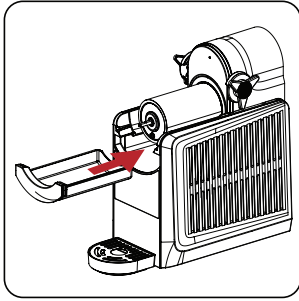

Install the condensation catch under the evaporator by sliding it into the rail grooves.

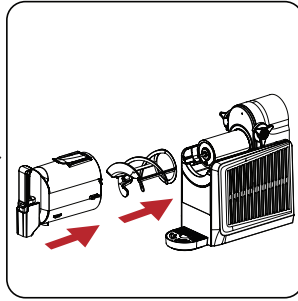

Install the auger by sliding it over the evaporator and rotating until it fits into place onto the pin.
Slide the vessel over the installed auger and evaporator.

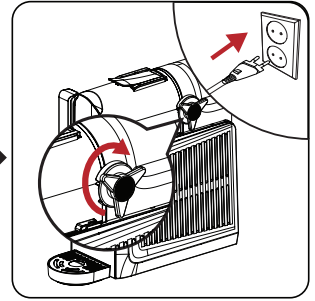

Lock the vessel in place with the bail handle. Plug in the appliance.

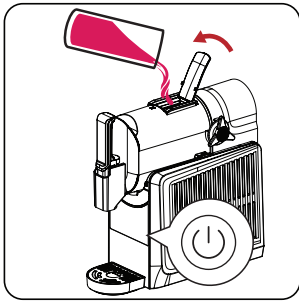

Add liquid(s) and/or blended ingredients through the easy-fill port and close the cover. Press the power button.

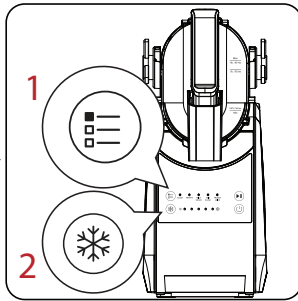

Press the Preset button to select the desired menu. Each menu comes with an optimal temperature setting. You can change the temperature if you want with the temperature setting button.

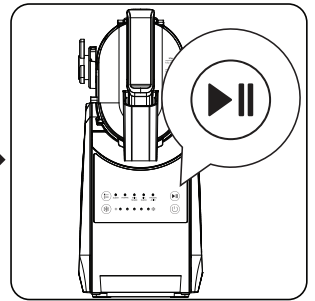

Press the Start/Stop button. The appliance will start to chill and stir the slush mixture. Processing time depends on the selected preset and the temperature of the materials.

3 Operation

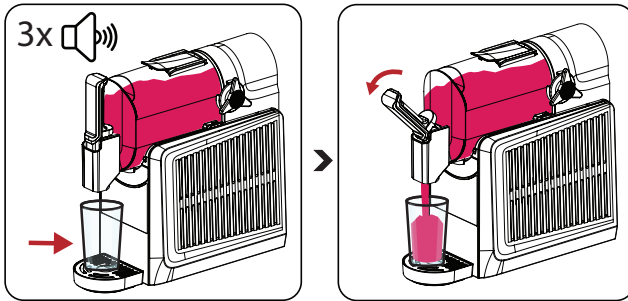

The LEDs will flash on and off while the slush drink is being prepared. Once the drink is ready, the LEDs will become solid and three beeps will sound. Place a cup under the spout.

Slowly pull the dispensing handle down to let the slush pour out.



When the slush is ready, the appliance will continue working to keep your drink at the ideal temperature. For the best taste, we recommend consuming the drink within 3 hours.



To maximise the compressor's lifespan, the standby time should not be more than 4 hours.

4 Cleaning and Maintenance

4.1 Automatic Cleaning Mode

Fill the vessel up to the MAX line. To start auto-clean, press the Preset button for 3 seconds. All the LEDs will blink in a clockwise rotation. The cleaning mode lasts 10 minutes. To exit cleaning mode while in cleaning mode, press the Start/Start/Stop button.

4.2 Cleaning and Maintenance



Auto-cleaning mode makes it easier to keep the appliance in the best condition. Start the cleaning cycle after each time you use the slush maker.



WARNING: Never use petrol, solvents, abrasive cleaners, metal objects or hard brushes to clean the appliance.



WARNING: Do not immerse the motor unit or power cord into water or other liquids and never hold under the running water.

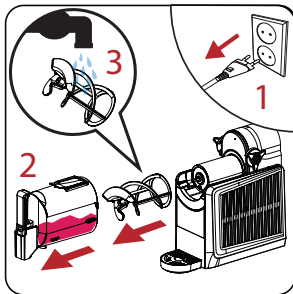

Unplug the appliance. Remove the vessel and empty the remaining slush. Remove the auger and clean it.

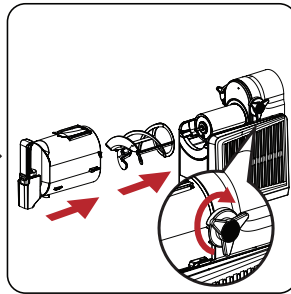

Reattach the auger and then reattach the vessel. Lock the vessel in place with the bail handle..

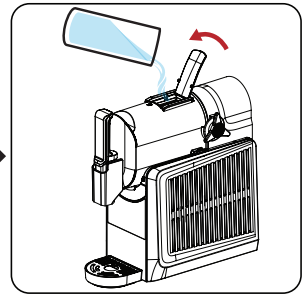

Fill the vessel with water until the MAX fill line.

4 Cleaning and Maintenance

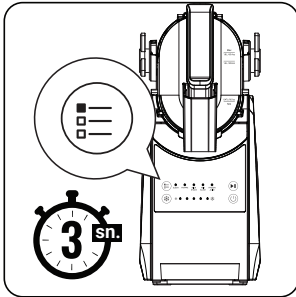

To enter cleaning mode, press the Preset button for 3 seconds. All the LEDs will blink in a clockwise rotation.

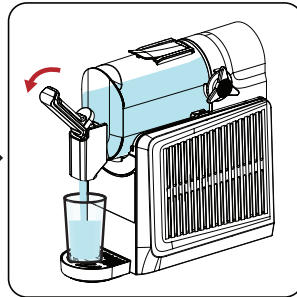

When the process is complete, the unit will automatically stop working. Pull the dispensing handle down and slowly drain the water from the unit.

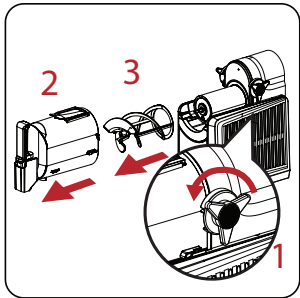

Loosen the bail handle and remove the vessel.



Rinse the vessel and auger well, then dry with a soft cloth.



Clean the condensation catch and drip tray with soapy water, then rinse and dry thoroughly.



Make sure the parts are completely dry before refitting them.



After cleaning, dry all parts with a soft cloth before using the appliance.

4 Cleaning and Maintenance

4.3 Storage

- If you do not plan to use the appliance for a long period of time, please store it carefully.
- Ensure that the appliance is unplugged, cooled down completely.
- Do not wrap the power cord around the appliance.
- Store the appliance in a cool and dry environment.
- Always make sure the appliance is kept out of reach of children.

4.4 Transportation and Handling

- Transport the appliance in its original packaging during handling and transport. The packaging protects the appliance from physical damage.
- Do not place heavy objects on the appliance or its packaging. The appliance may get damaged.
- If the appliance is dropped, it may stop working or permanent damage may occur.

4.5 Important points for energy saving

Turn off and unplug the appliance after each use.

5 Troubleshooting

Problem	Indicator	Cause	Solution
Auger is noisy.	Not Available	When the slush has low sugar content, this causes the evaporator to freeze.	Add sugar, syrup, etc. to the frozen mixture.
The auger is scraping the inside of the tank or splashing the liquid to the sides.	Not Available	The auger needs to be cleaned or its form is broken.	Remove the auger, clean it and refit it. If the problem persists, check whether the auger is crushed, warped, or bent. In that case, contact Customer Services to have the auger replaced.
Micro switch malfunction	All the preset menu LEDs and the temperature setting LEDs will flash in sequence.	The vessel may have been fitted incorrectly.	Make sure the vessel is fitted properly.. If the problem persists, contact Customer Services..
Tilt switch malfunction	The 1 and 3 temperature setting lights will flash and the appliance will beep three times.	The appliance is tilted at more than 60°.	Turn off the appliance and place it on a level surface before use. If the problem persists, contact Customer Services..
Sensor malfunction	The 1 and 5 temperature setting lights will flash and the appliance will beep three times.	The sensor has short circuited or there is a problem with the sensor.	Turn off and on the device. If the problem persists, contact Customer Services..

5 Troubleshooting

Problem	Indicator	Cause	Solution
Jammed rotor malfunction	The 3 and 5 temperature setting lights will flash and the appliance will beep three times.	May be due to the ingredients being too cold or having a low sugar content.	Turn off the appliance. Check the liquid. If the liquid hasn't frozen, add warm water (not hot water), empty out the fluid, turn the appliance back on, and start the cleaning cycle. Check whether the auger is working properly. If the auger is not working, this indicates a motor malfunction. Please contact Customer Services to have it repaired. If the auger is working normally, place a new drink and continue preparing it. Check the liquid. If the liquid is partially frozen or stuck to the auger, this shows that the liquid has a low sugar content. Turn off the appliance, then add warm water (not hot water), empty out the fluid, clean the auger's chamber, add new drink and add sugar to it (make sure the sugar content is more than 5%%).

5 Troubleshooting

Problem	Indicator	Cause	Solution
Hoot ingredients alarm	The 4 and 5 temperature setting lights will flash and the appliance will beep three times.	This could be due to the ingredients being warmer than 60°C.	Turn off the appliance. Empty out the ingredients in the feeding chamber and refill with ingredients cooler than 60°C. If the problem persists, contact Customer Services..
Connection error	The 2 and 3 temperature setting lights will flash and the appliance will beep three times.	This could be due to damage to the electronic board.	Please contact Customer Services to have it repaired.



55 Blanck Street, Ormeau Q 4208
P O Box 354, Ormeau Q 4208
p : 5549 3146 f : 5549 3546
ABN : 49 152 055 162

ORIGINAL MANUFACTURER'S WARRANTY ADVICE FORM

BEKO SMALL KITCHEN APPLIANCES (including Coffee Machines, Slushie Maker & Air Fryer)

24 months warranty, full parts and labour warranty only.

WARRANTY CONDITIONS

The following conditions apply only in relations to the warranty expressly given on this Warranty Advice Form supplied with the product. This warranty only applies to appliances purchased and used in Australia or New Zealand and is in addition to (and does not exclude, restrict or modify in any way) other rights and remedies under a law to which the appliances relate, including any non-excludable statutory guarantees in Australia and New Zealand. It applies to the original purchaser and for appliances used in domestic applications only.

- This warranty does not apply:
 - if the identification number attached to the appliance has been altered, rendered illegible or removed;
 - to light globes;
 - to paint and vitreous enamel finishes and glass;
 - to surfaces damaged by use of aerosols or cleaners;
 - if the appliance has been –
 - subject to misuse, abuse, negligence, accident, fire or floods;
 - connected or improper, inadequate or faulty electricity, gas, water or drainage services or intake or exhaust ducts or flues, or operated using incorrect or contaminated fuels or lubricants;
 - installed, maintained or operated otherwise than in accordance with the instructions furnished by Beko including the improper use of detergents, bleaches, cleaners or other additives;
 - damaged by foreign objects in the appliance;
 - serviced, repaired or altered otherwise than by Beko authorised service agents of Beko, or using other than Beko approved replacement parts.
- The purchaser shall be responsible for any expenses involved in making the appliances readily accessible for servicing, the purchaser shall be responsible for any costs of transporting the appliance or parts thereof to and from the nearest Beko authorised service agent.
- This warranty is the only expressed warranty given by Beko.
- Beko reserves the right to determine whether or not the fault is caused by faulty workmanship or material or that any part is defective.
- Where permitted by law, this warranty shall not apply to loss suffered through or resulting from the non-operation or the ineffective operation of the appliance or any part of the appliance.
- The purchaser must produce proof of the date of purchase together with this Warranty Advice Form when making a claim.
- Subject to your statutory rights as to the merchantable quality of the product or accessory, in the event of a product or accessory being replaced during the guarantee, the guarantee on the replacement will expire at the original date, i.e., 24 months from the original purchase date.
- Australia: For Appliances and services provided by Beko in Australia, Beko goods come with a guarantee by Beko that cannot be excluded under the Australian Consumer Law. You are entitled to a replacement or refund for a major failure and for compensation for any other reasonably foreseeable loss or damage. You are also entitled to have the Appliance repaired or replaced if the Appliance fails to be of acceptable quality and the failure does not amount to a major failure. 'Acceptable quality' and 'major failure' have the same meaning as referred to in the Australian Consumer Law.
- New Zealand: For Appliances and services provided by Beko in New Zealand, the Appliances come with a guarantee by Beko pursuant to the provisions of the Consumer Guarantees Act, the Sales of Goods Act and the Fair Trading Act. Where the Appliance was purchased in New Zealand for commercial purposes the Consumer Guarantee Act does not apply.

These Warranty Conditions supersedes and excludes all other representations, conditions and warranties, except those implied by legislation previously referred to.

For Service or Spare Parts: Aust 1300 282 356 NZ 0800 692 356

Beko A&NZ Pty Ltd
55 Blanck Street, Ormeau QLD,
4208 AUSTRALIA

www.beko.com.au

