

GoWISEUSA®

STEAM AIR FRYER USER MANUAL

Model No.: GW22991



Please read through this manual carefully before use

 **IMPORTANT SAFEGUARDS AND TIPS**

WWW.GOWISEUSA.COM

THANK YOU FOR YOUR PURCHASE!

Join

the GoWISE Community on Facebook, Instagram, Twitter, and Pinterest for updates, tips, and great deals!



Explore

recipes on our recipe App or www.gowiseproducts.com/blogs/recipes



Contact Our Customer Care Team

855-233-9199

support@gowiseusa.com

Live Chat at gowiseusa.com

M-F 8:30am - 4:00pm MST



Register Your Product

www.gowiseproducts.com/apps/product-registration

(The serial number is normally underneath the product. Please check there first.)



Specifications

Voltage: 120V, 60Hz

Watts: 1700W

Capacity: 7 Qt

Temp. Range: 180°F-400°F



TABLE OF CONTENTS

Register Your Product.....	2
Specifications.....	2
Important Safeguards.....	4
Electromagnetic Fields (EMF).....	5
Product Structure.....	6
Control Display.....	7
Cooking Presets Reference.....	8
Cooking Guide.....	9
Internal Temperature Chart.....	9
Tips.....	9
Set Up and Using Your Steam Air Fryer.....	10
Before First Use.....	10
The Basket and Crisper Tray.....	10
The Water Tank.....	11
The Water Tray.....	11
Using Your Steam Air Fryer.....	12
Steam Mode.....	14
Combo Mode.....	15
Cleaning Your Steam Air Fryer.....	16
Self Cleaning.....	16
Troubleshooting.....	17
Warranty.....	18

IMPORTANT SAFEGUARDS

HOUSEHOLD USE ONLY • READ ALL INSTRUCTIONS BEFORE USE

- 1. READ THE ENTIRE MANUAL BEFORE ATTEMPTING TO OPERATE.**
- Keep the box and packing material for storage.
- 3. DO NOT PLACE** the appliance on stove top surfaces.
- This appliance has a polarized plug (one prong is wider than the other). This plug is intended to fit into a polarized outlet only one way. **TO AVOID ELECTRIC SHOCK, DO NOT** force the plug into the outlet if it does not fit. If the plug does not fit fully into the outlet, reverse the plug. If it still does not fit, contact a qualified electrician. **DO NOT ATTEMPT** to modify the plug in any way.
- 5. DO NOT** immerse the power cord, plug, or any part of the appliance in water or any other liquids to avoid electric shock.
- 6. DO NOT** use the appliance if the plug, the power cord, or the appliance itself is damaged in any way.
- 7. ALWAYS** keep the power cord away from hot surfaces.
- 8. DO NOT** go to any unauthorized person to replace or fix the appliance.
- 9. DO NOT** plug the appliance in or operate the appliance with wet hands.
- 10. DO NOT** connect the appliance to an external timer switch or separate remote control system.
- 11. DO NOT PLACE** the appliance against a wall or any other appliances. Leave at least five inches of free space along the back, sides, and above the appliance.
- 12. DO NOT PLACE** anything on top of the appliance.
- 13. DO NOT PLACE** the appliance on or near combustible materials, such as a tablecloth or curtain.
- 14. DO NOT USE** the **GoWISE Steam Air Fryer** for any purpose other than described in this manual.
- 15. NEVER OPERATE** the appliance unattended.
- This appliance is **NOT INTENDED FOR USE** by persons with reduced physical, sensory, or mental capabilities or persons with a lack of experience and knowledge unless they are **UNDER THE SUPERVISION** of a responsible person or have been given proper instruction to use the appliance. This appliance is **NOT INTENDED FOR USE** by children. Make sure that the appliance is out of reach of children, especially when it is operating.
- Keep all the ingredients within the basket to prevent any contact with the heating elements. **DO NOT OVERFILL** the basket.
- 18. DO NOT** fill the basket with oil. Filling the basket with oil is a fire hazard.

IMPORTANT SAFEGUARDS

HOUSEHOLD USE ONLY • READ ALL INSTRUCTIONS BEFORE USE

19. DO NOT COVER OR BLOCK

the air inlet and outlet while the appliance is in operation. Doing so prevents even cooking and may damage the unit or cause it to overheat.

20. DO NOT touch the inside of the appliance while it is operating.

21. While air frying, hot air is released through the air outlet openings. Keep your hands and face at a safe distance from the steam and from the air outlet opening. **BE CAUTIOUS** of hot steam and air when you remove the basket from the appliance. Any accessible surface may become hot during use.

22. **IMMEDIATELY UNPLUG** the appliance if you see dark smoke coming out of the appliance. Wait for the smoke emission to stop before you remove the basket from the appliance.

23. **ENSURE** that the appliance is placed and operated on a horizontal, even, stable, and noncombustible surface.

24. This appliance is designed for **HOUSEHOLD USE ONLY**. It is not safe to use in environments, such as staff kitchens, farms, motels, and other non-residential environments.

25. If the **GoWISE Steam Air Fryer** is used improperly, for professional or semi-professional purposes, or if it is not used according to the instructions in this user manual, the warranty becomes invalid,

and the manufacturer will not be held liable for damages.

26. **ALWAYS** unplug the appliance after use.

27. **ALWAYS** wait 30 minutes for the appliance to cool down before handling, cleaning, or storing.

28. The base of the **GoWISE Steam Air Fryer** vents heat during the cooking process. Artificial stone countertops are not heat-resistant. It is the end user's responsibility to verify the heat capacity of their countertops. We recommend using a silicone pad or spare, non-artificial tile to protect your counters from heat damage. **The care and use of countertops is the responsibility of the end user.**

29. Over time, wear and tear is normal for the basket and crisper tray and will need to be replaced from time to time. Please contact GoWISE Customer Care or visit our website gowiseproducts.com to purchase these parts.

Electromagnetic Fields (EMF)

This appliance complies with all standards regarding Electromagnetic Fields (EMF). Under proper handling, the appliance is safe to use based on available scientific evidence.

**SAVE THESE
INSTRUCTIONS**

PRODUCT STRUCTURE

PARTS

1. Water Tank
2. LCD Control Display
3. Air Inlet
4. Crisper Tray
5. Basket
6. Handle
7. Water Tray
8. Air Outlet
9. Condensation Collector

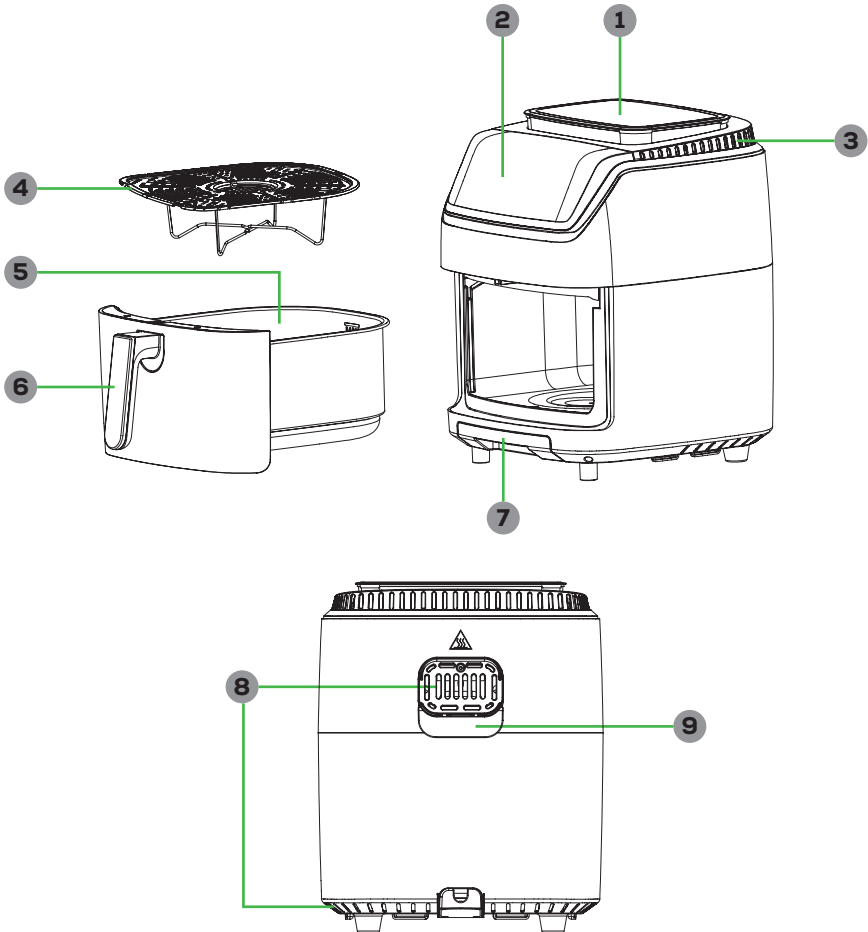

CONTROL DISPLAY

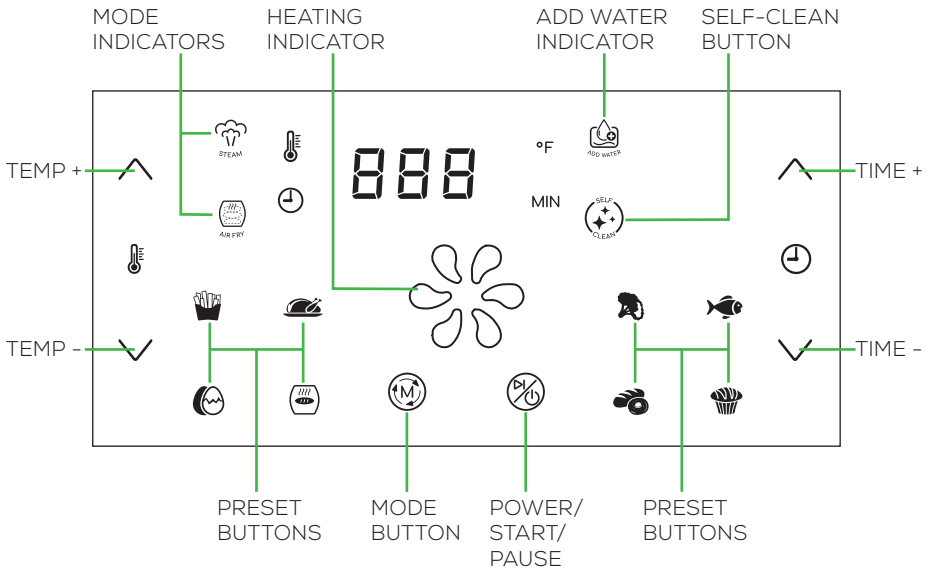

OPERATING BUTTONS

POWER/ START/PAUSE: Powers the unit on and off; starts and pauses the cooking process. Before pressing this button, ensure that the basket and water tank are inserted into the unit.

MODE: Switches between Air Fry, Steam and Combo mode. When the unit is in combo mode, the Air Fry and Steam icons will both be on. Press Mode button to switch between modes to see and adjust cooking times and temperature.

UP & DOWN arrows: Increase or decrease temperature and time.

SELF-CLEAN: Starts the self-cleaning function of the unit to clean limescale build-up.

INDICATORS

ADD WATER: Illuminates and beeps when the water level in the water tank is low.

AIR FRY: Illuminates when in Air Fry mode. This mode cooks your food with hot air.

STEAM: Illuminates when in Steam mode. This mode cooks your food with hot steam.

HEATING: The fan icon will illuminate throughout the cooking cycle to indicate that the heating element is running.

COOKING PRESETS REFERENCE

This Steam Air Fryer is equipped with a full touchscreen display with one-touch cooking presets. Each preset is set with a default time and temperature for Steam and Air Fry mode. To select a preset and mode, press the associated icon and press the  (MODE) button until the desired cooking mode displays on the screen. See default settings for each preset along with their adjustable ranges in the chart.

Preset	Steam Temp	Steam Time	Steam Range	Air Fry Temp	Air Fry Time	Air Fry Range
 Fries/Potato	212°F	20 min	1-60 mins	400°F	18 min	1-60 mins, 180°F - 400°F
 Chicken	212°F	30 min	1-60 mins	350°F	20 min	1-60 mins, 180°F - 400°F
 Eggs	212°F	18 min	1-60 mins	250°F	16 min	1-60 mins, 180°F - 400°F
 Broil	N/A	N/A	N/A	400°F	10 min	1-60 mins, 180°F - 400°F
 Vegetable	212°F	10 min	1-60 mins	320°F	12 min	1-60 mins, 180°F - 400°F
 Fish	212°F	10 min	1-60 mins	350°F	10 min	1-60 mins, 180°F - 400°F
 Bread/Bagel	212°F	4 min	1-60 mins	380°F	14 min	1-60 mins, 180°F - 400°F
 Bake	212°F	40 min	1-60 mins	310°F	30 min	1-60 mins, 180°F - 400°F

NOTES:

- Temperature is not adjustable in Steam mode for all presets.
- Temperature can be adjusted in Air Fry mode.
- The preset "Broil" is only available in Air Fry mode.

WARNING

Never use a cooking vessel filled with cooking oil or any other liquid with this unit! Fire Hazard or personal injury could result.

COOKING GUIDE

INTERNAL TEMPERATURE CHART

This chart should be used to check the temperature of cooked meats. Always review the USDA Food Safety Standards.

Food	Type	Internal Temperature
Beef + Veal	Ground	160°F (70°C)
	Steaks, Roasts: medium	160°F (70°C)
	Steaks, Roasts: rare	145°F (63°C)
Chicken + Turkey	Breasts	165°F (75°C)
	Ground, Stuffed	165°F (75°C)
	Whole bird, legs, thighs, wings	165°F (75°C)
Fish + Shellfish	Any type	145°F (63°C)
Lamb	Ground	160°F (70°C)
	Steaks, Roasts: medium	160°F (70°C)
	Steaks, Roast: rare	145°F (63°C)
Pork	Chops, Ground, Ribs, Roasts	160°F (70°C)
	Fully cooked Ham	140°F (60°C)

TIPS

- Small ingredients usually require shorter cooking times compared to larger ingredients.
- Shaking smaller ingredients midway through the cooking process will ensure the ingredients cook more evenly and have a better end result.
- Adding a very little amount of oil to fresh potatoes will give it a crispier result.
- Do not prepare extremely oily or greasy ingredients in the air fryer.
- Snacks that can be prepared in a traditional oven can also be prepared in the air fryer.
- The recommended amount of fries to allow for a crispy result is 17.5 oz.
- Pre-made dough requires a shorter cooking time than home-made dough.
- When making cake, quiche or ingredients with batter, use a baking pan or oven dish in the basket.

SET UP AND USING YOUR STEAM AIR FRYER

BEFORE FIRST USE

1. Remove all packaging materials, stickers, and labels.
2. Clean the basket and crisper tray with hot water, soap, and a non-abrasive sponge.
3. Wipe the inside and outside of the appliance with a clean cloth.
4. Set the unit to 350°F for about 5 minutes. This process will burn off any remaining residue left from the manufacturer. There may be a slight burning smell which will dissipate after a few minutes.
5. Your new GoWISE USA Steam Air Fryer is now ready for use!

CAUTION: DO NOT fill basket with oil or lard. The appliance uses rapid air circulation to fry.

THE BASKET AND CRISPER TRAY

Using the Basket and Crisper Tray

1. Grab the handle in the middle of the crisper tray and insert it into the basket. Ensure there is a tight fit.



2. Insert the basket into the steam air fryer. The steam air fryer will not turn on unless the basket is inserted properly.

NOTES:

- a. The crisper tray comes with retractable legs that can be used for broiling and steaming.
- b. Turn the tray over and pull out the legs and insert the crisper tray into the basket.

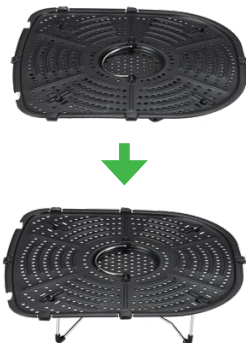

SET UP AND USING YOUR STEAM AIR FRYER

THE WATER TANK

Using the Water Tank for Steaming

1. Remove the water tank from the top of the steam air fryer.



2. Turn the water tank over and fill it with water. **NOTE:** The water tank's capacity is 4.5 cups and it is recommended to fill the water tank to its full capacity.



3. Close and tighten the cap on the water tank. Insert the water tank to the top of the steam air fryer completely.

THE WATER TRAY

Inserting and Draining the Water Tray







The water tray is located at the bottom of the steam air fryer and is used to collect the excess water from Steam mode.

1. Check the water tray halfway through the cooking cycle to ensure it does not overflow.
2. Empty the water tray and place it firmly into the bottom of the appliance.



SET UP AND USING YOUR STEAM AIR FRYER

USING YOUR STEAM AIR FRYER

1. Place the steam air fryer on a flat and even surface. **DO NOT PLACE THE UNIT ON A SURFACE THAT IS NOT HEAT RESISTANT. DO NOT PLACE THE UNIT ON STOVE TOP SURFACES.**
2. Plug your steam air fryer into a grounded wall socket.
3. Grab the handle in the middle of the crisper tray and place it in the basket. **DO NOT FILL THE BASKET WITH OIL OR ANY OTHER LIQUID.**
4. Place the ingredients in the basket and then slide the basket back into the appliance. The  (**POWER**) button on the LCD display should light up.
5. The steam air fryer should be in Air Fry mode by default.
 - a. Press the  (**MODE**) button to switch Air Fry mode to Steam mode. The STEAM icon will illuminate.
NOTE: The temperature for Steam mode is set to 212°F and cannot be changed.
 - b. Press the  button again to switch to Combo mode.
NOTE: The AIR FRY and STEAM icons will both illuminate on the panel.
6. Adjust the time and temperature as needed using the “^” or “v” arrows. Time can be adjusted in 1-minute increments between 1-60 minutes. Temperature can be adjusted in 5-degree increments between 180°F to 400°F. Hold down the “^” or “v” arrows to move through time and temperature quicker.
NOTE: To choose a preset, press the icon of the desired preset and the steam air fryer will set to time and temperature of that preset. You can also adjust the time and temperature of the selected preset by using the “^” and “v” arrows. See page 8 for reference on cooking presets.
7. Once you have set the time and temperature or selected a cooking preset (optional), press the  button to start the cooking cycle. The fan icon will illuminate to indicate that the steam air fryer is heating and the fan is circulating.
8. If you would like to make changes at any time during the cooking cycle, such as increasing temperature, adding more time or changing to a new preset, press the  button, make your adjustments, and press the  button to resume.
9. You may need to shake the ingredients midway through the cooking cycle to ensure even cooking. Pull the basket out of the steam air fryer by the handle (the unit will automatically power down), gently and carefully shake the ingredients inside the basket. Slide the basket back into the steam air fryer by carefully aligning the track inside the unit with the rim of the basket. The

SET UP AND USING YOUR STEAM AIR FRYER

USING YOUR STEAM AIR FRYER

steam air fryer will resume the cooking cycle.

- 10.** If you need to turn the unit off before the end of the cooking cycle, hold down the  button for 3 seconds. The display will read OFF and the fan may continue to run up to 20 seconds.
- 11.** Slide the basket out of the steam air fryer and place it on a pot holder.
NOTE: Oil from the ingredients will gather in the bottom of the basket. Be careful when sliding the basket out of the unit.
- 12.** To remove the ingredients, use silicone tipped tongs, or carefully pour ingredients out of the basket onto a plate.

NOTES:

- a.** Rapid Air Technology reheats the air inside the unit instantly. Therefore, removing the basket of the steam air fryer for a brief period of time will not interrupt the cooking process.
- b.** If using tongs or any other cooking utensils, make sure to use non-abrasive, non-metal tongs to avoid scratching the ceramic coating on the basket and the crisper tray.

To order replacement parts please contact our Customer Care Team.

855-233-9199







support@gowiseusa.com

Live Chat at gowiseusa.com



M-F 8:30am - 4:00pm MST

SET UP AND USING YOUR STEAM AIR FRYER

STEAM MODE









1. Fill up the water tank with water. The water tank's capacity is 4.5 cups and it is recommended to fill the water tank to its full capacity.
2. Insert the water tank and basket into the steam air fryer completely. The  (POWER) button should illuminate on the control panel.
3. Insert the water tray into the bottom of the steam air fryer.
4. Press the  button to turn on the steam air fryer. The steam air fryer will be in default mode. Press the  (MODE) button to switch to Steam mode. The STEAM icon will illuminate.
5. Adjust the time needed using the "∧" or "∨" arrows. Time can be adjusted in 1-minute increments between 1-60 minutes. Hold down the "∧" or "∨" arrows to move through time quicker.
NOTE: The temperature for Steam mode is set at 212°F and cannot be adjusted.
6. Once you have set the time or selected a cooking preset (optional), press the  button to start the cooking cycle. The fan icon will illuminate to indicate that the steam air fryer is heating.
7. If you would like to make changes at any time during the cooking cycle, such as adding more time or changing to a new preset, press the  button, make your adjustments, and press the  button to resume.
8. If you need to turn the unit off before the end of the cooking cycle, hold down the  button for 3 seconds. The display will read OFF and the fan may continue to run up to 20 seconds.
9. Slide the basket out of the steam air fryer and place it on a pot holder.
10. To remove the ingredients, use silicone tipped tongs, or carefully pour ingredients out of the basket onto a plate.

NOTES:

- a. All presets (except Broil) are set with a time and temperature for Steam mode. To select a preset, press the icon of the desired preset and the steam air fryer will set to time and temperature of that preset. You can also adjust the time of the selected preset by using the "∧" and "∨" arrows. See page 8 for reference on cooking presets.
- b. If the water tank does not have enough water or runs out of water during the cooking cycle, the "ADD WATER" icon  will illuminate on the panel and the steam air fryer will beep continuously. Press the  button and remove the water tank to fill with water.

SET UP AND USING YOUR STEAM AIR FRYER

COMBO MODE

1. Fill up the water tank with water.
2. Insert the water tank and basket into the steam air fryer completely. The  button should illuminate on the control panel.
3. Press the  button to turn on the steam air fryer. The steam air fryer will be in Air Fry mode by default. The AIR FRY icon will illuminate on the panel.
4. Once you have set your settings for Air Fry mode, press the  button and the steam air fryer will switch to Steam mode. The STEAM icon will illuminate on the panel. If desired, adjust the time as needed using the “^” or “v” arrows for Steam mode. Time can be adjusted in 1-degree increments.
NOTE: The temperature for Steam mode is set at 212°F and cannot be adjusted.
5. Once you have set the time for Steam mode, press the  button again and the STEAM and AIR FRY icons will both illuminate on the display.
6. Press the  button to start the cooking cycle. The steam air fryer will start cooking in Steam mode then it will automatically switch to Air Fry mode.
NOTE: If the water tank does not have enough water or runs out of water during the Steam cycle, the “ADD WATER” icon will illuminate on the panel and the steam air fryer will beep continuously. Press the  button and remove the water tank to fill with water.
7. If you would like to make changes at any time during the cooking cycle, such as increasing temperature, adding more time or changing to a new preset, press the  button, make your adjustments, and press the  button to resume.
8. If you need to turn the unit off before the end of the cooking cycle, hold down the  button for 3 seconds. The display will read OFF and the fan may continue to run up to 20 seconds.
9. Slide the basket out of the steam air fryer and place it on a pot holder.
10. To remove the ingredients, use silicone tipped tongs, or carefully pour ingredients out of the basket onto a plate.

NOTES:

- a. Rapid Air Technology reheats the air inside the unit instantly. Therefore, removing the basket of the steam air fryer for a brief period of time will not interrupt the cooking process.
- b. If using tongs or any other cooking utensils, make sure to use non-abrasive, non-metal tongs to avoid scratching the ceramic coating on the basket and the crisper tray.

CLEANING YOUR STEAM AIR FRYER

Clean the unit after every use.

It is recommended to empty the water tank after each use if the steam air fryer is not used often.

- 1.** Unplug the unit. **ALWAYS WAIT UNTIL THE UNIT HAS COOLED TO A SAFE TEMPERATURE BEFORE HANDLING.**
- 2.** Wipe the outside of the unit with a damp cloth.
- 3.** Wash the basket and crisper tray with hot water, soap and a non-abrasive sponge. You can remove any stuck-on food by using a degreasing liquid soap. For any hard-to-remove food, soak the basket and crisper tray in hot water.
- 4.** Clean the inside of the appliance with a lightly dampened, non-abrasive sponge or cloth. Be careful not to get the inside of the appliance too wet and never submerge in water.
- 5.** Scrub the heating element with a cleaning brush to remove any food debris.

Self Cleaning

The steam air fryer features a self-cleaning function to clean limescale out of the water tank after about 20 hours of use. We recommend using the self-cleaning function after every use if the appliance is not used often.

- 1.** Mix ½ ounce of vinegar and 2 cups of water thoroughly.
- 2.** Add the mixture to the water tank. Insert the water tank in the steam air fryer.
- 3.** Insert the basket into the appliance and the steam air fryer should turn on.
- 4.** Press the SELF CLEAN button and the machine will begin the self-cleaning process.
- 5.** Once the self-cleaning process is complete, the steam air fryer will automatically turn off.
- 6.** Remove the water tank and rinse out the water tank with water. Fill the water tank with water and insert the water tank into the steam air fryer. Press the SELF-CLEAN button. This will help flush out the vinegar and remove any odd taste from the steam air fryer. Repeat this step if you think it is necessary.

TROUBLESHOOTING

Problem	Possible Cause	Solution
The appliance is not turning on	The appliance is not plugged in	Plug the appliance into a grounded wall socket.
	You have not set the timer	Set the timer using the control display to the correct time on the appliance.
	The basket is not pushed into the unit	Push the basket into the unit (see pg. 12).
Food is not cooked	The basket has been overfilled with ingredients	Place smaller batches of ingredients in the basket. Smaller batches are fried more evenly.
	The set temperature is too low	Increase the temperature to the required setting.
Food is cooked unevenly	Ingredient positioning or overflow	Ingredients that lay on top or across from each other (e.g. fries) need to be shaken midway through cooking.
Fried snacks are not crispy after frying	Some snacks are crispier when traditionally fried	Cook oven snacks or lightly brush some oil onto the snacks for a crispier result.
Basket does not slide into the fryer properly	Overfilled basket	Do not fill the basket beyond the MAX fill indicator line.
White smoke comes out of the fryer	It is normal for white smoke to appear when prepping greasy ingredients	When frying greasy ingredients, a large amount of oil will leak into the basket. The oil produces white smoke and the basket may heat up more than usual. This does not affect the appliance or end food result.
	The basket is still greasy	Clean the unit properly after each use.
Fresh fries are fried unevenly in the fryer	Potatoes are not fresh	Use fresh potatoes and place them in the freezer for 30 minutes before air frying to help them stay firm during frying.
	Potato sticks have not been rinsed properly prior to frying	Make sure to rinse the potato sticks properly to remove the starch prior to frying.

If your GoWISE Steam Air Fryer displays any error codes, please contact our Customer Care Team.

855-233-9199

support@gowiseusa.com

Live Chat at gowiseusa.com

M-F 8:30am - 4:00pm MST

WARRANTY

GoWISE USA warrants all products against defects in materials and workmanship for **one (1) year** effective from the date of purchase.

GoWISE USA will replace any products that are found to be defective due to manufacturer flaws based on eligibility. Refunds issued by GoWISE USA must be purchased directly from GoWISE USA and are only available to the original purchaser within the first 30 days. We do not issue refunds for items bought by thirdparty retailers.

This warranty extends only to personal use and does not extend to products that has been used for commercial, rental or any other use this product was not intended for. There are no warranties other than the warranties expressly set forth with each product.

This warranty is non-transferrable. GoWISE USA is not responsible in any way for any damages, losses, or inconveniences caused by equipment failure by user negligence, abuse, or use noncompliant with the user manual or any additional safety, use, or warnings included in the product packaging and manual.

This warranty only covers purchases within the 48 contiguous states of United States of America. For purchases made outside the 48 contiguous states, such as AK, HI, PR, or Canada, we will replace the unit under the one-year warranty upon receipt of a proven defect by video or picture. However, the replacement will only ship to a freight forwarder or address within the 48 contiguous United States. The consumer is responsible for arranging shipment outside of the 48 contiguous states.

GoWISE USA assumes no liability for damage caused using this product other than for its intended use or as instructed in the user manual. Some states do not allow this exclusion or limitation of incidental or consequential losses, so the foregoing disclaimer may not apply to you. This warranty gives you specific legal rights and you may also have other rights which may vary from state to state.

ALL EXPRESSED AND IMPLIED WARRANTIES INCLUDING THE WARRANTY OF MERCHANTABILITY, ARE LIMITED TO THE PERIOD OF THE LIMITED WARRANTY.

NOTE: General Warranty excludes refurbished / auction items.

This warranty does not cover products that are purchased in the following conditions:

- Open Box
- Like New
- Used
- Renewed

WARRANTY

Additional 60-Days Warranty

You can extend your 1-year warranty by an additional 60 days. Log onto [www.gowiseproducts.com/apps/ product-registration](http://www.gowiseproducts.com/apps/product-registration) and register your product within the first 14 days of your purchase for the extended warranty.

DEFECTIVE PRODUCTS & RETURNS

If your product is defective within the 1-year warranty period, please email our Customer Care Team at support@gowiseusa.com. To expedite your issue, please provide the 4 items below:

1. Copy of the invoice, order information, or gift receipt showing the date of purchase
2. Serial number, usually found on a sticker located on the bottom on back of the unit
3. Picture or video of the issue or defect that you are experiencing
4. Shipping address information

Authorized Retailers:

Amazon

GoWISE USA

WayFair

Houzz

Home Depot

etailz

MorningSave.com

Bed Bath & Beyond

Jet.com

Walmart.com

Macy's

kroger.com

weightwatchers.com

GoWISEUSA®

WWW.GOWISEUSA.COM

855-233-9199

support@gowiseusa.com

Live Chat at gowiseusa.com

M-F 8:30am - 4:00pm MST

- To ensure the correct use of this appliance, read these instructions carefully and thoroughly.
- Please keep this manual for future reference.
- Thank you for purchasing this GoWISE USA Steam Air Fryer.

USE PROMO CODE: **LIVewiseraF**

10%
OFF

YOUR NEXT **GoWISEUSA®** PURCHASE

