



**PRODUCT GUIDE**  
**MODEL 463224611**  
**Sears Item No. 16138**  
**Sears Model No. 415.16138110**

**IMPORTANT:** Fill out the product record information below.

Serial Number \_\_\_\_\_  
 See rating label on grill for serial number.

Date Purchased \_\_\_\_\_

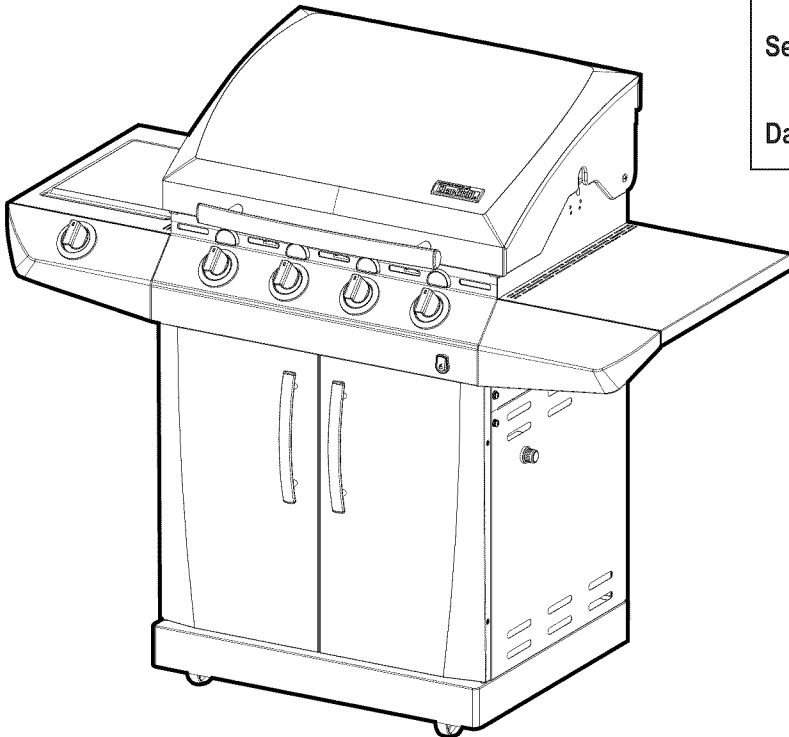

For support and to register your grill, please visit us at [www.charbroil.com](http://www.charbroil.com)

If you have questions or need assistance during assembly, please call **1-888-430-7870**.



**CONVERSION-READY**

Easily converts from (LP) liquid propane to (NG) natural gas

Visit the grill accessory aisle for a complete kit.

**Estimated assembly time: 30 minutes**

The following are trademarks registered by W.C. Bradley Co. in the U.S. Patent and Trademark Office: Caldera®; Charcoal2Go®; Char-Broil®; American Gourmet®; Bandera®; Brush Hawg®; CB 940®; Char-Diamonds®; Char-Broil Charcoal/Gas®; Everybody Grills®; Grill 2 Go®; Grill 2 Go® Express®; Grill Lovers®; Infrared Grilling That's All About U®; Keepers of the Flame®; Magneto®; New Braunfels Smoker Company®; Patio Bistro®; Patio Caddie®; Patio Kitchen®; Pro-Sear®; RED®; Quantum®; Santa Fe®; Sear and Grill®; Sierra®; Signature Series®; Sure2Burn®; The Big Easy®; U®; Wild West Tradition®; and the following marks:



The following are trademarks of W.C. Bradley Co.: America's Legendary Barbeque Company™; Advantage Series™; Auto-Clean™; Chef Tested™; Commercial Series™; Designer Series™; Diamond Flame™; Double Chef™; Everybody Outside™; FastStart™; FlavorMaster™; Front Avenue™; Grill 2 Go® Advantage™; Grill 2 Go® Ice™; Hog and Yard Bird™; H2O Smoker™; Infrared. Grilling's Juicy Little Secret™; Incredible Taste. Infallible Results™; Infrared Inside™; Let's Grill Something Together™; Longhorn™; Precision Flame™; Quick2Burn™; QuickSet™; Ready When You Are™; Season, Set, And Savor™; Sizzle On The Grill™; SureFire™; Torchfork™; Trentino™; Universal Grill Parts™; You Bring the Party™ TEC™ is a trademark of Tec Infrared Grills.

Protected under one or more of the following U.S. Patents: 5,421,319; 5,458,309; 5,579,755; 5,996,573; 6,114,666; 6,135,104; 6,209,533; 6,331,108; 6,484,900; 6,595,197; 6,640,803; 6,729,873; 6,792,935; 6,951,213; 6,935,327; D405,643; D406,005; D406,009; D413,043; D413,229; D414,982; D415,388; D416,164; D416,441; D417,587; D417,588; D422,516; D423,274; D423,876; D428,303; D430,772; D435,396; D436,004; D438,059; D438,060; D438,427; D439,110; D442,505; D443,179; D443,354; D443,464; D448,614; D448,615; D448,616; D448,975; D449,492; D451,759; D454,028; D454,031; D455,205; D455,206; D456,202; D460,312; D460,313; D461,359; D465,123; D465,693; D466,439; D477,501; D478,472; D480,914; D491,410; D494,009; D494,413; D498,523; D500,359; D504,048; D535,000; D551,489; D553,430; D562,619; D562,628; D613,116 Canada: D97,504; D99,355; D102,037; D104,200; D108,377; 2,315,567; Other Patents Pending. © 2010 W.C. Bradley Company







## TABLE OF CONTENTS



For Your Safety .....	2-3
Use and Care .....	4-9
Limited Warranty .....	10
Parts List .....	11
Parts Diagram .....	12
Assembly .....	13-24
Troubleshooting .....	25-27
Registration Card .....	31



### Safety Symbols



The symbols and boxes shown below explain what each heading means. Read and follow all of the messages found throughout the manual.

	<b>WARNING</b>	
<b>WARNING:</b> Indicates an potentially hazardous situation which, if not avoided, could result in death or serious injury.		

	<b>CAUTION</b>	
<b>CAUTION:</b> Indicates a potentially hazardous situation or unsafe practice which, if not avoided, may result in minor or moderate injury.		

	<b>DANGER</b>	
<b>DANGER:</b> Indicates an imminently hazardous situation which, if not avoided, will result in death or serious injury.		

	<b>DANGER</b>	
<b>If you smell gas:</b>		
<ol style="list-style-type: none"><li>1. Shut off gas to the appliance.</li><li>2. Extinguish any open flame.</li><li>3. Open lid.</li><li>4. If odor continues, keep away from the appliance and immediately call your gas supplier or your fire department.</li></ol>		

	<b>WARNING</b>	
<ol style="list-style-type: none"><li>1. Do not store or use gasoline or other flammable liquids or vapors in the vicinity of this or any other appliance.</li><li>2. An LP cylinder not connected for use shall not be stored in the vicinity of this or any other appliance.</li></ol>		

	<b>CAUTION</b>	
<b>For residential use only. Do not use for commercial cooking.</b>		

**THIS GRILL IS FOR OUTDOOR USE ONLY.**

 **CAUTION:**  
Read and follow all safety statements, assembly instructions, and use and care directions before attempting to assemble and cook.

**INSTALLER/ASSEMBLER:**  
Leave this manual with consumer.

**CONSUMER:**  
Keep this manual for future reference.

 **WARNING:**  
Failure to follow all manufacturer's instructions could result in serious personal injury and/or property damage.

 **CAUTION:**  
Some parts may contain sharp edges – especially as noted in the manual! Wear protective gloves if necessary.

**WARNING**

**CALIFORNIA PROPOSITION 65**

1. Combustion by-products produced when using this product contain chemicals known to the State of California to cause cancer, birth defects, and other reproductive harm.
2. This product contains chemicals, including lead and lead compounds, known to the State of California to cause cancer, birth defects or other reproductive harm.

***Wash your hands after handling this product.***

**Installation Safety Precautions**

- Use grill, as purchased, only with LP (propane) gas and the regulator/valve assembly supplied. If your grill is Dual Fuel ready, a conversion kit must be purchased for use with natural gas.
- Grill installation must conform with local codes, or in their absence of local codes, with either the *National Fuel Gas Code, ANSI Z223.1/ NFPA 54, Natural Gas and Propane Installation Code, CSA B149.1, or Propane Storage and Handling Code, B149.2, or the Standard for Recreational Vehicles, ANSI A 119.2/NFPA 1192, and CSA Z240 RV Series, Recreational Vehicle Code, as applicable.*
- All electrical accessories (such as rotisserie) must be electrically grounded in accordance with local codes, or *National Electrical Code, ANSI / NFPA 70 or Canadian Electrical Code, CSA C22.1.* Keep any electrical cords and/or fuel supply hoses away from any hot surfaces.
- This grill is safety certified for use in the United States and/or Canada only. Do not modify for use in any other location. Modification will result in a safety hazard.

**WARNING**

**Do not attempt to repair or alter the hose/valve/regulator for any “assumed” defect. Any modification to this assembly will void your warranty and create the risk of a gas leak and fire. Use only authorized replacement parts supplied by manufacturer.**

**CAUTION**

Using pots larger than 6 quarts in capacity could exceed weight limit of the side burner shelf or side shelf, resulting in failure of grill cart components.

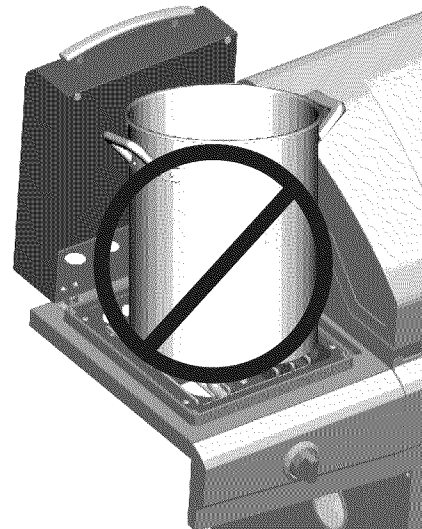

## USE AND CARE



# DANGER



- **NEVER** store a spare LP cylinder under or near the appliance or in an enclosed area.

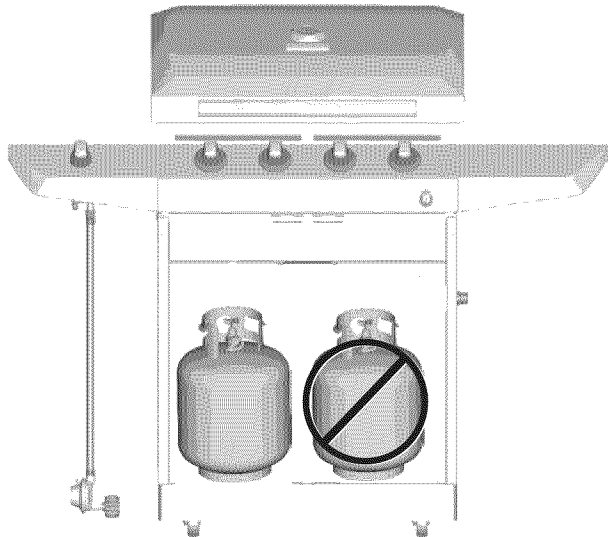

- **Never** fill a cylinder beyond 80% full.
- An over filled or improperly stored cylinder is a hazard due to possible gas release from the safety relief valve. This could cause an intense fire with risk of property damage, serious injury or death.
- If you see, smell or hear gas escaping, immediately get away from the LP cylinder/appliance and call your fire department.

### LP Cylinder Removal, Transport and Storage

- Turn OFF all control knobs and LP cylinder valve. Turn coupling nut counterclockwise by hand only - do not use tools to disconnect. Loosen cylinder screw beneath bottom shelf, then lift LP cylinder up and out of cart. Install safety cap onto LP cylinder valve. Always use cap and strap supplied with valve. **Failure to use safety cap as directed may result in serious personal injury and/or property damage.**

- A disconnected LP cylinder in storage or being transported must have a safety cap installed (as shown). Do not store an LP cylinder in enclosed spaces such as a carport, garage, porch, covered patio or other building. Never leave an LP cylinder inside a vehicle which may become overheated by the sun.

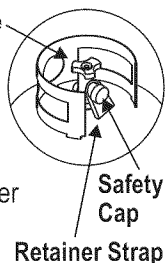

- Do not store an LP cylinder in an area where children play.

### LP Cylinder

- The LP cylinder used with your grill must meet the following requirements:

- Use LP cylinders only with these required measurements: 12" (30.5cm) (diameter) x 18" (45.7 cm) (tall) with 20 lb. (9 kg.) capacity maximum.
- LP cylinders must be constructed and marked in accordance with specifications for LP cylinders of the U.S. Department of Transportation (DOT) or for Canada, CAN/CSA-B339, cylinders, spheres and tubes for transportation of dangerous goods. Transport Canada (TC). See LP cylinder collar for marking.

- LP cylinder valve must have:

- Type 1 outlet compatible with regulator or grill.
- Safety relief valve.
- UL listed Overfill Protection Device (OPD). This OPD safety

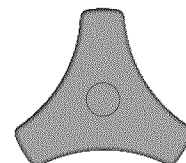

OPD Hand Wheel

feature is identified by a unique triangular hand wheel. **Use only LP cylinders equipped with this type of valve.**

- LP cylinder must be arranged for vapor withdrawal and include collar to protect LP cylinder valve. Always keep LP cylinders in upright position during use, transit or storage.



LP cylinder in upright position for vapor withdrawal

### LP (Liquefied Petroleum Gas)

- LP gas is nontoxic, odorless and colorless when produced. **For Your Safety**, LP gas has been given an odor (similar to rotten cabbage) so that it can be smelled.
- LP gas is highly flammable and may ignite unexpectedly when mixed with air.

### LP Cylinder Filling

- Use only licensed and experienced dealers.
- LP dealer **must purge new cylinder** before filling.
- Dealer should **NEVER** fill LP cylinder more than 80% of LP cylinder volume. Volume of propane in cylinder will vary by temperature.
- A frosty regulator indicates gas overfill. Immediately close LP cylinder valve and call local LP gas dealer for assistance.
- Do not release liquid propane (LP) gas into the atmosphere. This is a hazardous practice.
- To remove gas from LP cylinder, contact an LP dealer or call a local fire department for assistance. Check the telephone directory under "Gas Companies" for nearest certified LP dealers.

## LP Cylinder Exchange

- Many retailers that sell grills offer you the option of replacing your empty LP cylinder through an exchange service. Use only those reputable exchange companies that inspect, precision fill, test and certify their cylinders. **Exchange your cylinder only for an OPD safety feature-equipped cylinder as described in the "LP Cylinder" section of this manual.**
- Always keep new and exchanged LP cylinders in upright position during use, transit or storage.
- **Leak test new and exchanged LP cylinders BEFORE connecting to grill.**
- Place dust cap on cylinder valve outlet whenever the cylinder is not in use. Only install the type of dust cap on the cylinder valve outlet that is provided with the cylinder valve. Other types of caps or plugs may result in leakage of propane.

## LP Cylinder Leak Test For your safety

- Leak test must be repeated each time LP cylinder is exchanged or refilled.
- Do not smoke during leak test.
- Do not use an open flame to check for gas leaks.
- Grill must be leak tested outdoors in a well-ventilated area, away from ignition sources such as gas fired or electrical appliances. During leak test, keep grill away from open flames or sparks.
- Use a clean paintbrush and a 50/50 mild soap and water solution. Brush soapy solution onto areas indicated by arrows in figure below.
- ▲ **Do not use household cleaning agents.** Damage to gas train components can result.

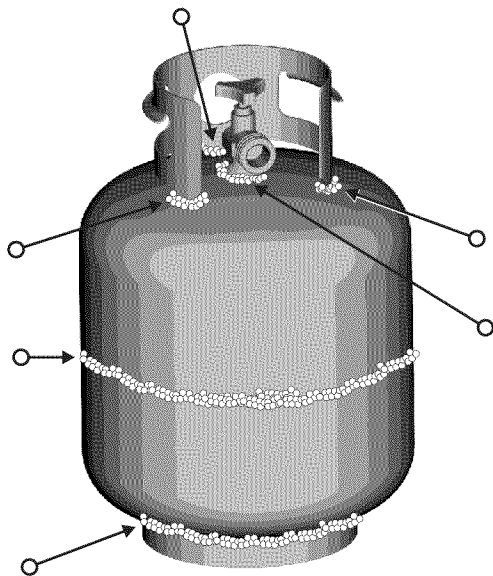

	<b>WARNING</b>	
If "growing" bubbles appear do not use or move the LP cylinder. Contact an LP gas supplier or your fire department!		

## Connecting Regulator to the LP Cylinder

1. LP cylinder must be properly secured onto grill. (Refer to assembly section.)
2. Turn all control knobs to the OFF position.
3. Turn LP cylinder OFF by turning hand-wheel clockwise to a full stop.
4. Remove the protective cap from LP cylinder valve. Always use cap and strap supplied with valve.

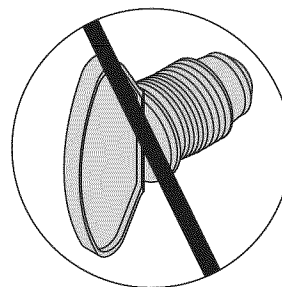
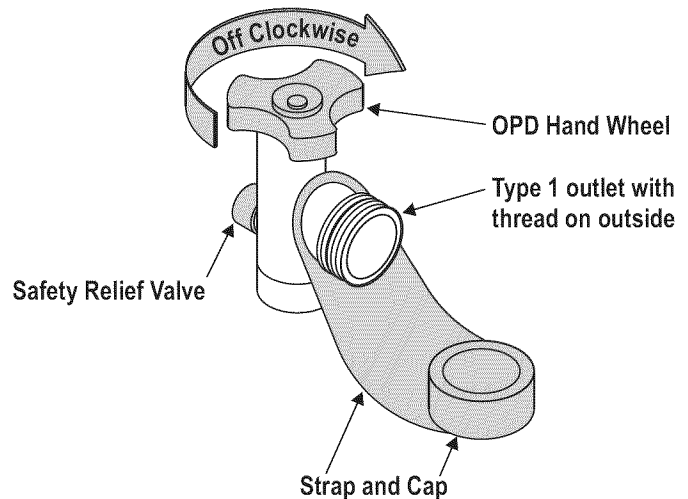

**Do not use a POL transport plug (plastic part with external threads)! It will defeat the safety feature of the valve.**

5. Hold regulator and insert nipple into LP cylinder valve. Hand-tighten the coupling nut, holding regulator in a straight line with LP cylinder valve so as not to cross-thread the connection.

**Nipple has to be centered into the LP cylinder valve.**

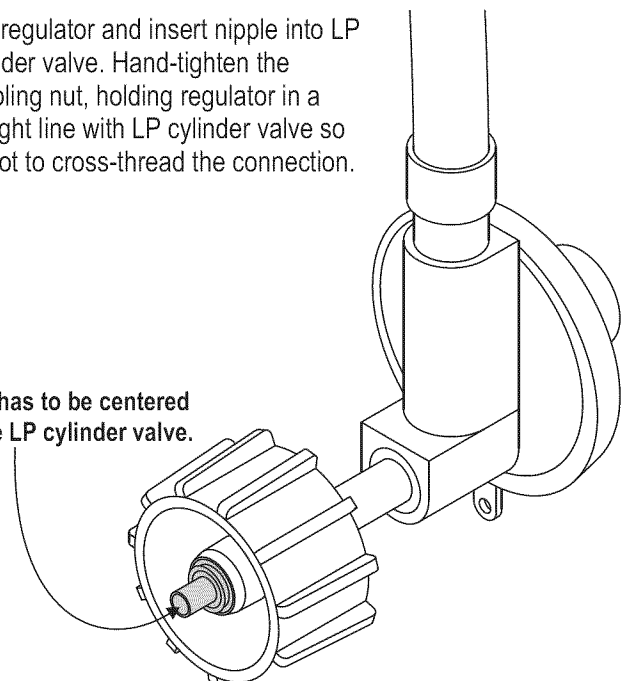

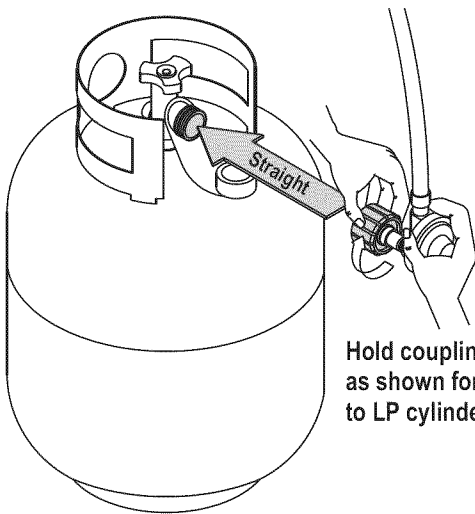

Hold coupling nut and regulator as shown for proper connection to LP cylinder valve.

6. Turn the coupling nut clockwise and tighten to a full stop. The regulator will seal on the back-check feature in the LP cylinder valve, resulting in some resistance. **An additional one-half to three-quarters turn is required to complete the connection. Tighten by hand only – do not use tools.**

**NOTE:**

If you cannot complete the connection, disconnect regulator and repeat steps 5 and 6. If you are still unable to complete the connection, **do not use this regulator!**

	<b>DANGER</b>	
<ul style="list-style-type: none"> <li>Do not insert any tool or foreign object into the valve outlet or safety relief valve. You may damage the valve and cause a leak. Leaking propane may result in explosion, fire, severe personal injury, or death.</li> </ul>		

	<b>WARNING</b>	
<ul style="list-style-type: none"> <li>Outdoor gas appliance is not intended to be installed in or on a boat.</li> <li>Outdoor gas appliance is not intended to be installed in or on an RV.</li> <li>Never attempt to attach this grill to the self-contained LP gas system of a camper trailer or motor home.</li> <li>Do not use grill until leak-tested.</li> <li>If a leak is detected at any time, STOP and call the fire department.</li> <li>If you cannot stop a gas leak, <i>immediately</i> close LP cylinder valve and call LP gas supplier or your fire department!</li> </ul>		

**Leak Testing Valves, Hose and Regulator**

1. Turn all grill control knobs to OFF.
2. Be sure regulator is tightly connected to LP cylinder.
3. Completely open LP cylinder valve by turning hand wheel counterclockwise. If you hear a *rushing sound*, turn gas off immediately. There is a major leak at the connection. **Correct before proceeding.**
4. Brush soapy solution onto areas circled below, or other similar fittings on your grill.

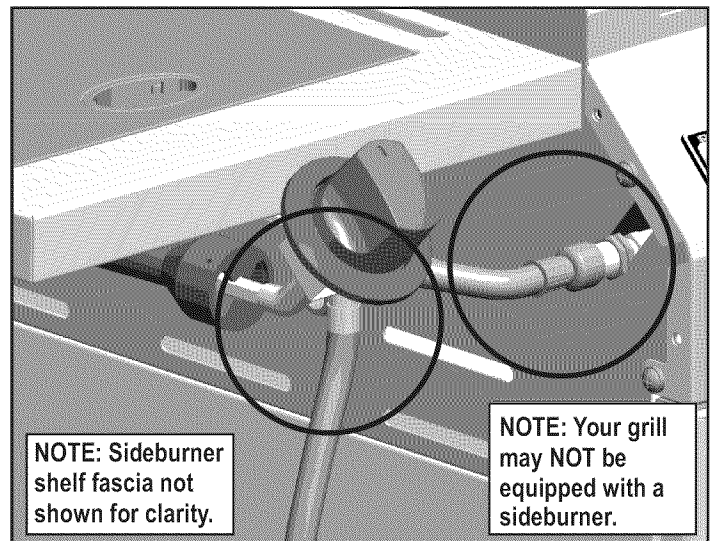
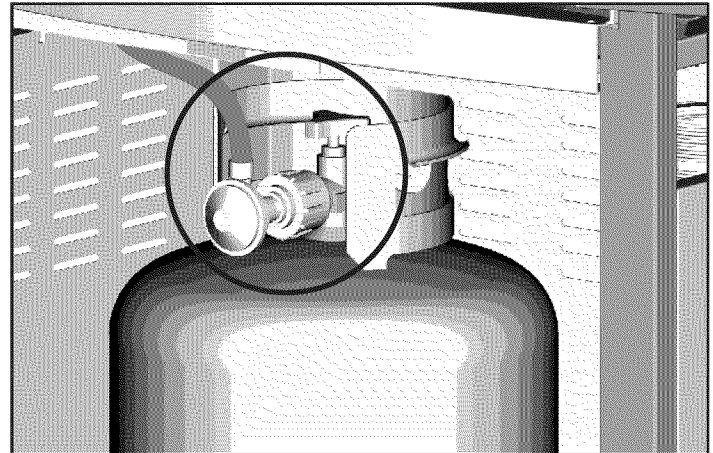

**NOTE:** Sideburner shelf fascia not shown for clarity.

**NOTE:** Your grill may NOT be equipped with a sideburner.

5. If “growing” bubbles appear, there is a leak. Close LP cylinder valve immediately and retighten connections. **If leaks cannot be stopped do not try to repair.** Call for replacement parts.
6. Always close LP cylinder valve after performing leak test by turning hand wheel clockwise.



## WARNING



### For Safe Use of Your Grill and to Avoid Serious Injury:

- Do not let children operate or play near grill.
- Keep grill area clear and free from materials that burn.
- Do not block holes in sides or back of grill.
- Check burner flames regularly.
- Use grill only in well-ventilated space. NEVER use in enclosed space such as carport, garage, porch, covered patio, or under an overhead structure of any kind.
- Do not use charcoal or ceramic briquets in a gas grill. (*Unless briquets are supplied with your grill.*)
- **Use grill at least 3 ft. from any wall or surface.** Maintain 10 ft. clearance to objects that can catch fire or sources of ignition such as pilot lights on water heaters, live electrical appliances, etc.

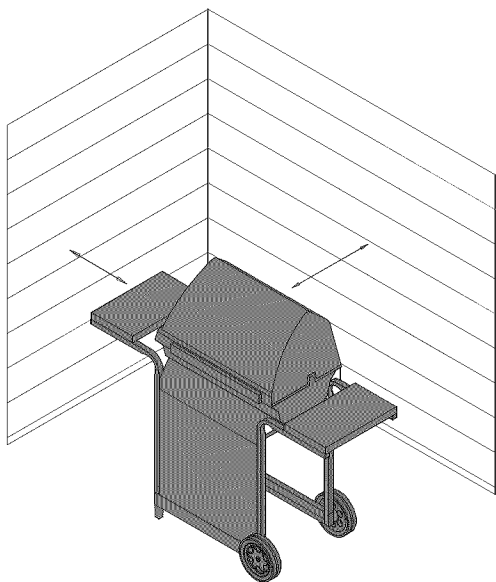

#### • Apartment Dwellers:

Check with management to learn the requirements and fire codes for using an LP gas grill in your apartment complex. If allowed, use outside on the ground floor with a three (3) foot clearance from walls or rails. Do not use on or under balconies.

- **NEVER attempt to light burner with lid closed. A buildup of non-ignited gas inside a closed grill is hazardous.**
- **Never operate grill with LP cylinder out of correct position specified in assembly instructions.**
- **Always close LP cylinder valve and remove coupling nut before moving LP cylinder from specified operation position.**

### Safety Tips

- ▲ Before opening LP cylinder valve, check the coupling nut for tightness.
- ▲ When grill is not in use, turn off all control knobs and LP cylinder valve.
- ▲ Never move grill while in operation or still hot.
- ▲ Use long-handled barbecue utensils and oven mitts to avoid burns and splatters.
- ▲ Maximum load for sideburner and side shelf is 10 lbs.
- ▲ The grease tray **must** be inserted into grill and emptied after each use. Do not remove grease tray until grill has completely cooled.
- ▲ Clean grill often, preferably after each cookout. If a bristle brush is used to clean any of the grill cooking surfaces, ensure no loose bristles remain on cooking surfaces prior to grilling. It is not recommended to clean cooking surfaces while grill is hot.
- ▲ If you notice grease or other hot material dripping from grill onto valve, hose or regulator, turn off gas supply at once. Determine the cause, correct it, then clean and inspect valve, hose and regulator before continuing. Perform a leak test.
- ▲ Keep ventilation openings in cylinder enclosure (grill cart) free and clear of debris.
- ▲ Do not store objects or materials inside the grill cart enclosure that would block the flow of combustion air to the underside of either the control panel or the firebox bowl.
- ▲ The regulator may make a humming or whistling noise during operation. This will not affect safety or use of grill.
- ▲ If you have a grill problem see the "Troubleshooting Section".
- ▲ If the regulator frosts, turn off grill and LP cylinder valve immediately. This indicates a problem with the cylinder and it should not be used on any product. Return to supplier!



## CAUTION



- **Putting out grease fires by closing the lid is not possible. Grills are well ventilated for safety reasons.**
- **Do not use water on a grease fire. Personal injury may result. If a grease fire develops, turn knobs and LP cylinder off.**
- **Do not leave grill unattended while preheating or burning off food residue on HI. If grill has not been regularly cleaned, a grease fire can occur that may damage the product.**

### Ignitor Lighting

- ▲ **Do not lean over grill while lighting.**
  1. Turn **OFF** gas burner control valves.
  2. Turn **ON** gas at LP cylinder.
  3. **Open lid during lighting.**
  4. To ignite, push and turn ignition burner knob to **HI**.
  5. Push and hold **ELECTRONIC IGNITION** button until the burner lights.
  6. If ignition does NOT occur in 5 seconds, turn the burner controls **OFF**, wait 5 minutes and repeat the lighting procedure.
  7. To ignite remaining burners, turn knob to the **HI** position starting with the burners closest to **IGNITION BURNERS** first. If ignitor does not work, follow match lighting instructions.

*Lighting instructions are continued on the next page*

## Ignitor Lighting (continued)

### 8. For grills equipped with ELECTRONIC IGNITION at each burner:

Repeat steps 4 through 6 to light each burner.

### 9. Once each burner has ignited, turn knobs to desired setting.



## WARNING



**Turn controls and gas source or tank OFF when not in use.**



## CAUTION



**If ignition does NOT occur in 5 seconds, turn the burner controls OFF, wait 5 minutes and repeat the lighting procedure. If the burner does not ignite with the valve open, gas will continue to flow out of the burner and could accidentally ignite with risk of injury.**

## Match-Lighting

### ▲ Do not lean over grill while lighting.

1. **Open lid.** Turn **ON** gas at LP cylinder.
2. Place match into match holder (hanging from side panel of grill). Light match; then light burner by placing match through the match light hole on right or left side of grill.
3. Push in and turn far right or far left burner knob to the **HI** position, depending on match light hole selected. Be sure burner lights and stays lit.
4. Light adjacent burners in sequence by pushing knobs in and turning to the **HI** position.

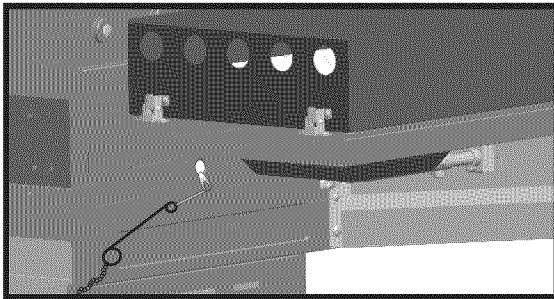

## Sideburner Ignitor Lighting

### ▲ Do not lean over grill while lighting.

1. **Open sideburner lid.** Turn **ON** gas at LP cylinder.
2. Turn sideburner knob to the **HI** position, push and hold **ELECTRONIC IGNITOR** button.
3. If sideburner does NOT light within 5 seconds, turn knob to **OFF**, wait 5 minutes, then repeat lighting procedure.

## Sideburner Match Lighting

1. **Open sideburner lid.** Turn **ON** gas at LP cylinder.
2. Place lit match near burner.
3. Turn sideburner knob to the **HI** position. Be sure burner lights and stays lit.

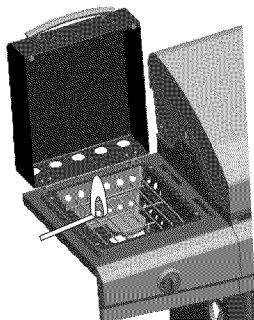

## Burner Flame Check

- Remove cooking grates and flame tamers. Light burners, rotate knobs from **HI** to **LOW**. You should see a smaller flame in **LOW** position than seen on **HI**. Perform burner flame check on sideburner, also. Always check flame prior to each use. If only low flame is seen refer to "Sudden drop or low flame" in the *Troubleshooting* Section.

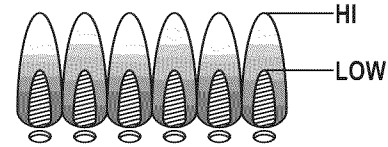

## Turning Grill Off

- Turn all knobs to the **OFF** position. Turn LP cylinder **OFF** by turning hand-wheel clockwise to a full stop.

## Ignitor Check

- **Turn gas off at LP cylinder.** Press and hold electronic ignitor button. "Click" should be heard and spark seen each time between each collector box or burner and electrode. See "*Troubleshooting*" if no click or spark.

## Valve Check

- **Important: Make sure gas is off at LP cylinder before checking valves.** Knobs lock in **OFF** position. To check valves, first push in knobs and release, knobs should spring back. If knobs do not spring back, replace valve assembly before using grill. Turn knobs to **LOW** position then turn back to **OFF** position. Valves should turn smoothly.

## Hose Check

- Before each use, check to see if hoses are cut or worn. Replace damaged hoses before using grill. Use only valve/hose/regulator specified by manufacturer.

## General Grill Cleaning

- Do not mistake brown or black accumulation of grease and smoke for paint. Interiors of gas grills are not painted at the factory (**and should never be painted**). Apply a strong solution of detergent and water or use a grill cleaner with scrub brush on insides of grill lid and bottom. Rinse and allow to completely air dry. **Do not apply a caustic grill/oven cleaner to painted surfaces.**
- **Plastic parts:** Wash with warm soapy water and wipe dry.
  - ▲ Do not use citrisol, abrasive cleaners, degreasers or a concentrated grill cleaner on plastic parts. Damage to and failure of parts can result.
- **Porcelain surfaces:** Because of glass-like composition, most residue can be wiped away with baking soda/water solution or specially formulated cleaner. Use nonabrasive scouring powder for stubborn stains.
- **Painted surfaces:** Wash with mild detergent or nonabrasive cleaner and warm soapy water. Wipe dry with a soft nonabrasive cloth.
- **Stainless steel surfaces:** To maintain your grill's high quality appearance, wash with mild detergent and warm soapy water and wipe dry with a soft cloth after each use. Baked-on grease deposits may require the use of an abrasive plastic cleaning pad. Use only in direction of brushed finish to avoid damage. Do not use abrasive pad on areas with graphics.
- **Cooking surfaces:** If a bristle brush is used to clean any of the grill cooking surfaces, ensure no loose bristles remain on cooking surfaces prior to grilling. It is not recommended to clean cooking surfaces while grill is hot.



# CAUTION



## SPIDER ALERT!

SPIDER AND WEBS  
INSIDE BURNER TUBE

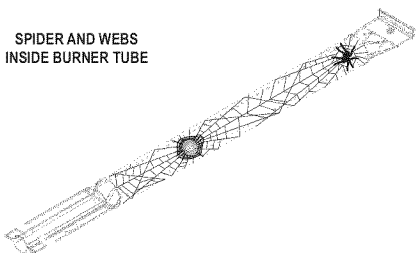

If you notice that your grill is getting hard to light or that the flame isn't as strong as it should be, take the time to check and clean the venturi's.

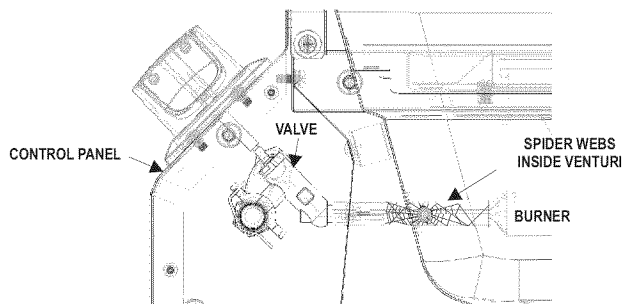

In some areas of the country, spiders or small insects have been known to create "flashback" problems. The spiders spin webs, build nests and lay eggs in the grill's venturi tube(s) obstructing the flow of gas to the burner. The backed-up gas can ignite in the venturi behind the control panel. This is known as a flashback and it can damage your grill and even cause injury.

To prevent flashbacks and ensure good performance the burner and venturi assembly should be removed from the grill and cleaned before use whenever the grill has been idle for an extended period.

### Storing Your Grill

- Clean cooking grates.
- Store in dry location.
- When LP cylinder is connected to grill, store outdoors in a well-ventilated space and out of reach of children.
- Cover grill if stored outdoors. Choose from a variety of grill covers offered by manufacturers.
- Store grill indoors ONLY if LP cylinder is turned off and disconnected, removed from grill and stored outdoors.
- When removing grill from storage, follow "Cleaning the Burner Assembly" instructions before starting grill.

### Cleaning the Burner Assembly

Follow these instructions to clean and/or replace parts of burner assembly or if you have trouble igniting grill.

1. Turn gas OFF at control knobs and LP cylinder.
2. Remove cooking grates and flame tamers.

3. Remove carryover tubes and burners.
4. Detach electrode from burner.

**NOTE:** Removal/Detachment method will depend on the burner configuration. See different configurations in illustrations below.

5. Carefully lift each burner up and away from valve openings. We suggest three ways to clean the burner tubes. Use the one easiest for you.

- (A) Bend a stiff wire (a light weight coat hanger works well) into a small hook. Run the hook through each burner tube several times.



- (B) Use a narrow bottle brush with a flexible handle (do not use a brass wire brush), run the brush through each burner tube several times.

- (C) **Wear eye protection:** Use an air hose to force air into the burner tube and out the burner ports. Check each port to make sure air comes out each hole.

6. Wire brush entire outer surface of burner to remove food residue and dirt.
7. Clean any blocked ports with a stiff wire such as an open paper clip.
8. Check burner for damage, due to normal wear and corrosion some holes may become enlarged. If any large cracks or holes are found replace burner.

**VERY IMPORTANT: Burner tubes must reengage valve openings. See illustrations at right.**

9. Attach electrode to burner.
10. Carefully replace burners.
11. Attach burners to brackets on firebox.
12. Reposition carryover tubes and attach to burners. Replace flame tamers and cooking grates.

Correct  
burner-to-valve  
engagement

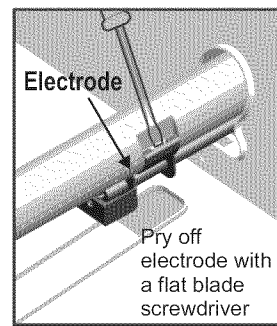
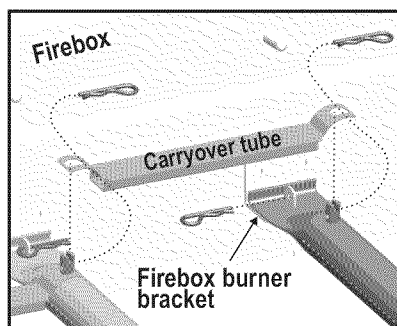
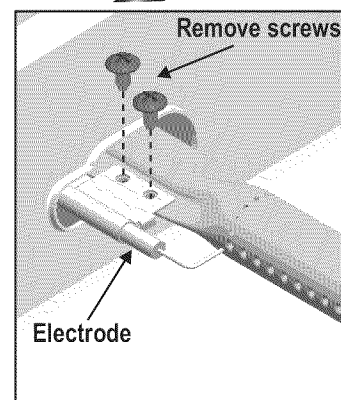
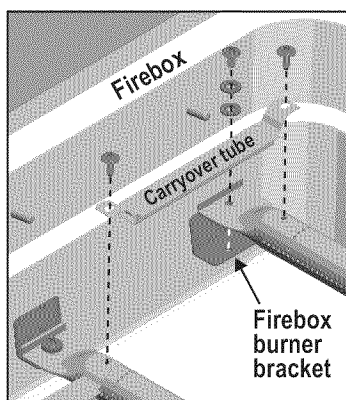
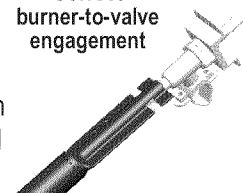

## LIMITED WARRANTY

This warranty only applies to units purchased from an authorized retailer. Manufacturer warrants to the **original consumer-purchaser** only that this product shall be free from defects in workmanship and materials after correct assembly and under normal and reasonable home use for the periods indicated below beginning on the date of purchase\*. The manufacturer reserves the right to require that defective parts be returned, postage and or freight pre-paid by the consumer for review and examination.

<u>SCOPE OF COVERAGE</u>	<u>PERIOD OF COVERAGE</u>	<u>TYPE OF FAILURE COVERAGE</u>
Burner	3 years from date of purchase*	PERFORATION, MANUFACTURING, AND MATERIAL DEFECTS ONLY
Firebox	2 years from date of purchase*	
All Other Parts	1 year from date of purchase*	

\*Note: A dated sales receipt WILL be required for warranty service.

**The original consumer-purchaser will be responsible for all shipping charges for parts replaced under the terms of this limited warranty.**

This limited warranty is applicable in the United States and Canada only, is only available to the original owner of the product and is not transferable. **Manufacturer requires proof of your date of purchase. Therefore, you should retain your sales slip or invoice.** Registering your product is not a substitute for proof of purchase and the manufacturer is not responsible for or required to retain proof of purchase records.

This limited warranty applies to the functionality of the product ONLY and does not cover cosmetic issues such as scratches, dents, corruptions or discoloring by heat, abrasive and chemical cleaners or any tools used in the assembly or installation of the appliance, surface rust, or the discoloration of stainless steel surfaces. **RUST is not considered a manufacturing or materials defect.**

**This limited warranty will not reimburse you for the cost of any inconvenience, food, personal injury or property damage.**

### ITEMS MANUFACTURER WILL NOT PAY FOR:

1. Shipping cost, standard or expedited, for warranty and replacement parts
2. Service calls to your home.
3. Repairs when your product is used for other than normal, single-family household or residential use.
4. Damage, failures, or operating difficulties resulting from accident, alteration, careless handling, misuse, abuse, fire, flood, acts of God, improper installation or maintenance, installation not in accordance with electrical or plumbing codes, or use of products not approved by the manufacturer.
5. Any food loss due to product failures or operating difficulties.
6. Replacement parts or repair labor costs for units operated outside the United States or Canada.
7. Pickup and delivery of your product.
8. Repairs to parts or systems resulting from unauthorized modifications made to the product.
9. The removal and/or reinstallation of your product.

### DISCLAIMER OF IMPLIED WARRANTIES and LIMITATION OF REMEDIES

Repair or replacement of defective parts is your exclusive remedy under the terms of this limited warranty. In the event of parts availability issues, the manufacturer reserves the right to substitute like or similar parts that are equally functional.

Manufacturer will not be responsible for any consequential or incidental damages arising from the breach of either this limited warranty or any applicable implied warranty, or for failure or damage resulting from acts of God, improper care and maintenance, grease fire, accident, alteration, replacement of parts by anyone other than Manufacturer, misuse, transportation, commercial use, abuse, hostile environments (inclement weather, acts of nature, animal tampering), improper installation or installation not in accordance with local codes or printed manufacturer instructions.

THIS LIMITED WARRANTY IS THE SOLE EXPRESS WARRANTY GIVEN BY THE MANUFACTURER. NO PRODUCT PERFORMANCE SPECIFICATION OR DESCRIPTION WHEREVER APPEARING IS WARRANTED BY MANUFACTURER EXCEPT TO THE EXTENT SET FORTH IN THIS LIMITED WARRANTY. ANY IMPLIED WARRANTY PROTECTION ARISING UNDER THE LAWS OF ANY STATE, INCLUDING IMPLIED WARRANTY OF MERCHANTABILITY OR FITNESS FOR A PARTICULAR PURPOSE OR USE, IS HEREBY LIMITED IN DURATION TO THE DURATION OF THIS LIMITED WARRANTY.

**Neither dealers nor the retail establishment selling this product has any authority to make any additional warranties or to promise remedies in addition to or inconsistent with those stated above.** Manufacturer's **maximum liability**, in any event, shall not exceed the purchase price of the product paid by the original consumer.

NOTE: Some states do not allow an exclusion or limitation of incidental or consequential damages, so some of the above limitations or exclusions may not apply to you. This limited warranty gives you specific legal rights as set forth herein. You may also have other rights which vary from state to state. In the state of California only, if refinishing or replacement of the product is not commercially practicable, the retailer selling this product or the Manufacturer will refund the purchase price paid for the product, less the amount directly attributable to use by the original consumer-purchaser prior to discovery of the nonconformity. In addition, in the state of California only, you may take the product to the retail establishment selling this product in order to obtain performance under this limited warranty.

**If you wish to obtain performance of any obligation under this limited warranty, you should write to:**

**Consumer Relations  
P. O. Box 1240  
Columbus, GA 31902-1240**

Consumer returns will not be accepted unless a valid Return Authorization is first acquired. Authorized returns are clearly marked on the outside of the package with an RA number and the package is shipped freight/postage pre-paid. Consumer returns that do not meet these standards will be refused.

## PARTS LIST

Key	Qty	Description
A	1	BOTTOM SHELF
B	1	TANK SCREW, F/ BOTTOM SHELF
C	2	CASTER, LOCKING
D	2	CASTER, FIXED
E	1	CART LEFT SIDE PANEL
F	1	GROMMET, F/ REGULATOR HOLE
G	1	CART RIGHT SIDE PANEL
H	1	CART LOWER BACK PANEL
I	1	FRONT BRACE
J	1	LEFT RAIL, F/ GREASE TRAY
K	1	RIGHT RAIL, F/ GREASE TRAY
L	1	FIREBOX
M	1	MATCH HOLDER
N	4	MAIN BURNER
O	2	ELECTRODE, F/ MAIN BURNER, 900MM WIRE
P	3	CARRYOVER TUBE W/ COTTER PIN
Q	1	IGNITER SWITCH MODULE
R	1	HOSE VALVE REGULATOR ASSEMBLY
S	1	MAIN CONTROL PANEL
T	1	ELECTRONIC IGNITION MODULE
U	1	CAP F/ EI MODULE
V	1	GREASE TRAY
W	1	ELECTRODE F/ SIDEBURNER
X	1	ELECTRODE WIRE, F/ SIDEBURNER
Y	5	BEZEL, F/ CONTROL KNOB
Z	5	CONTROL KNOB
AA	1	CART UPPER BACK PANEL
BB	1	LEFT SIDE SHELF, F/ SB
CC	1	FASCIA, F/ LEFT SIDE SHELF
DD	1	DRIP PAN, F/ SB
EE	4	RUBBER BUMPER, LID
FF	1	LID, F/ SB
GG	1	SIDEBURNER BURNER
HH	1	RIGHT SIDE SHELF
II	1	FASCIA, F/ RIGHT SIDE SHELF
JJ	1	OUTER TOP LID INSERT
KK	1	INNER TOP LID INSERT
LL	1	HANDLE F/ TOP LID
MM	2	RUBBER BUMPER, RECTANGLE, F/ TOP LID

Key	Qty	Description
NN	1	HEAT SHIELD F/ TANK
OO	4	TEMPERATURE GAUGE, UFC MOUNTED
PP	1	LOGO PLATE
QQ	1	HARDWARE F/ TOP LID ASSEMBLY
RR	1	LEFT DOOR, NO HANDLE
SS	2	DOOR HANDLE
TT	1	RIGHT DOOR, NO HANDLE
UU	4	FLAME TAMER
VV	3	COOKING GRATE
WW	1	GRATE, F/ SB
XX	1	WARMING RACK
YY	2	ELECTRODE, F/ MAIN BURNER, 600MM WIRE

### NOT Pictured

Key	Qty	Description
...	2	DOOR MAGNET
...	1	CASTER PIN
...	1	HARDWARE PACK
...	1	ASSEMBLY MANUAL, ENGLISH
...	1	ASSEMBLY MANUAL, SPANISH

**NOTE:** Some grill parts shown in the assembly steps may differ slightly in appearance from those on your particular grill model. However, the method of assembly remains the same.

# PARTS DIAGRAM

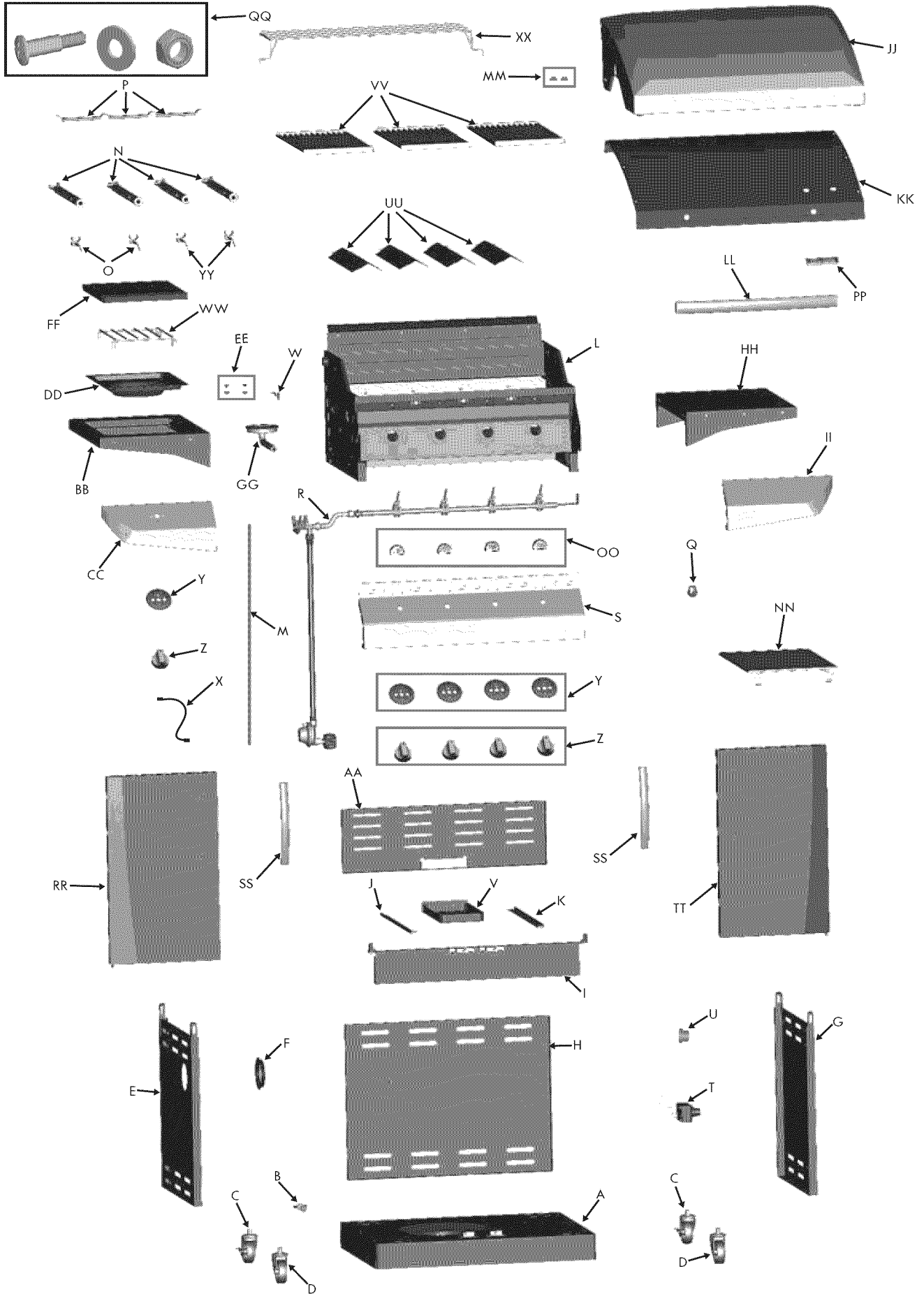

## ASSEMBLY

**1**

Place bottom shelf upside down. Insert Bent U Pin into the caster mounting plate to lock it in place, shown A. Spin the caster clockwise into the threads on the bottom shelf until secure. Remove the Bent U Pin and repeat for remaining casters. Make sure the two locking casters are secured at the rear and the non-locking casters are secured at the front. After all 4 casters are secure remove the Bent U Pin and save for future maintenance.

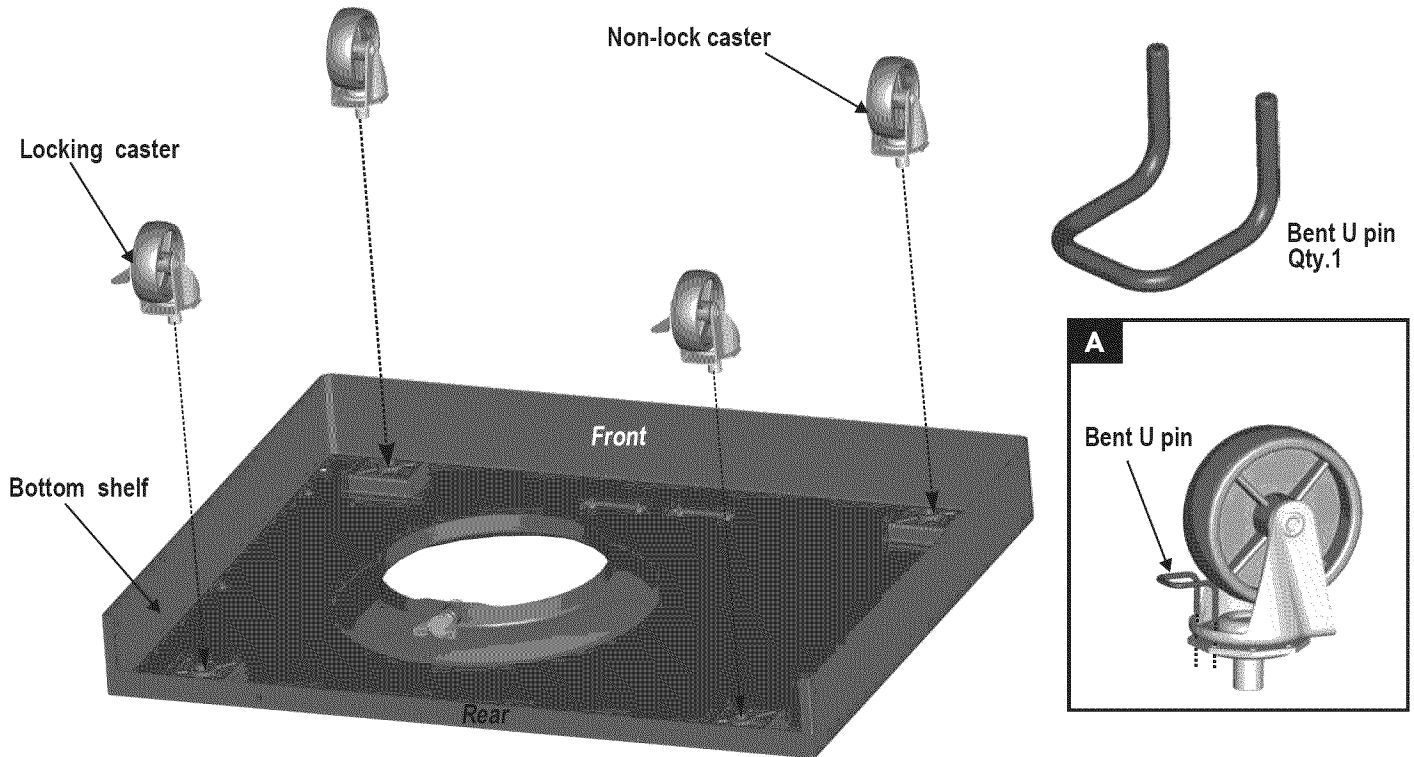

**2**

Attach side panels to bottom shelf using three 1/4-20x1/2" screws, 7mm lock washers, and 7mm flat washers per panel. **IMPORTANT:** Panel with large hole must be on left side of bottom shelf.

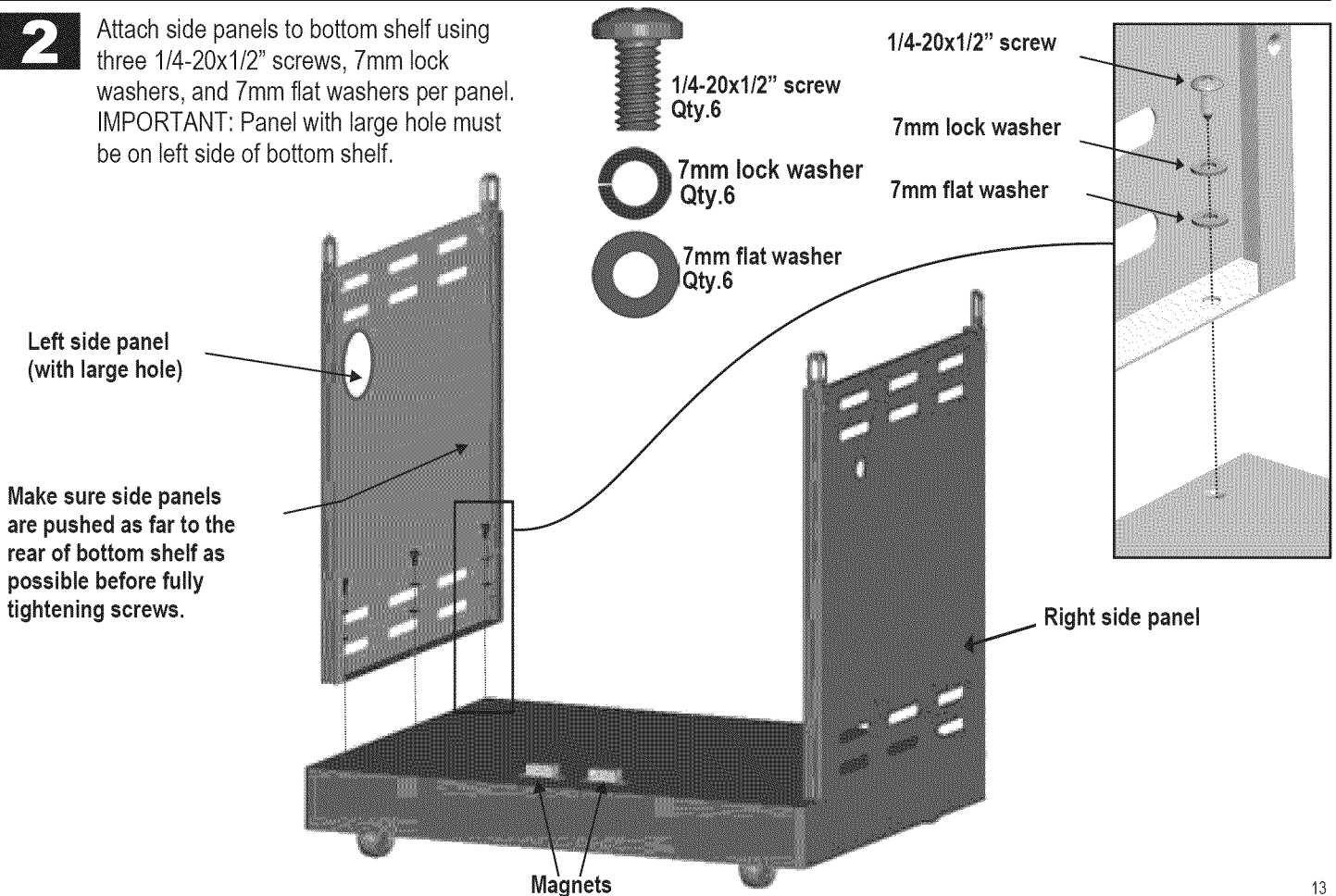

**3**

Place lower back panel between side panels at rear of bottom shelf. Secure lower back panel to side panels using four 1/4-20x1/2" screws, 7mm lock washers, and 7mm flat washers.



1/4-20x1/2" screw  
Qty.4



7mm lock washer  
Qty.4

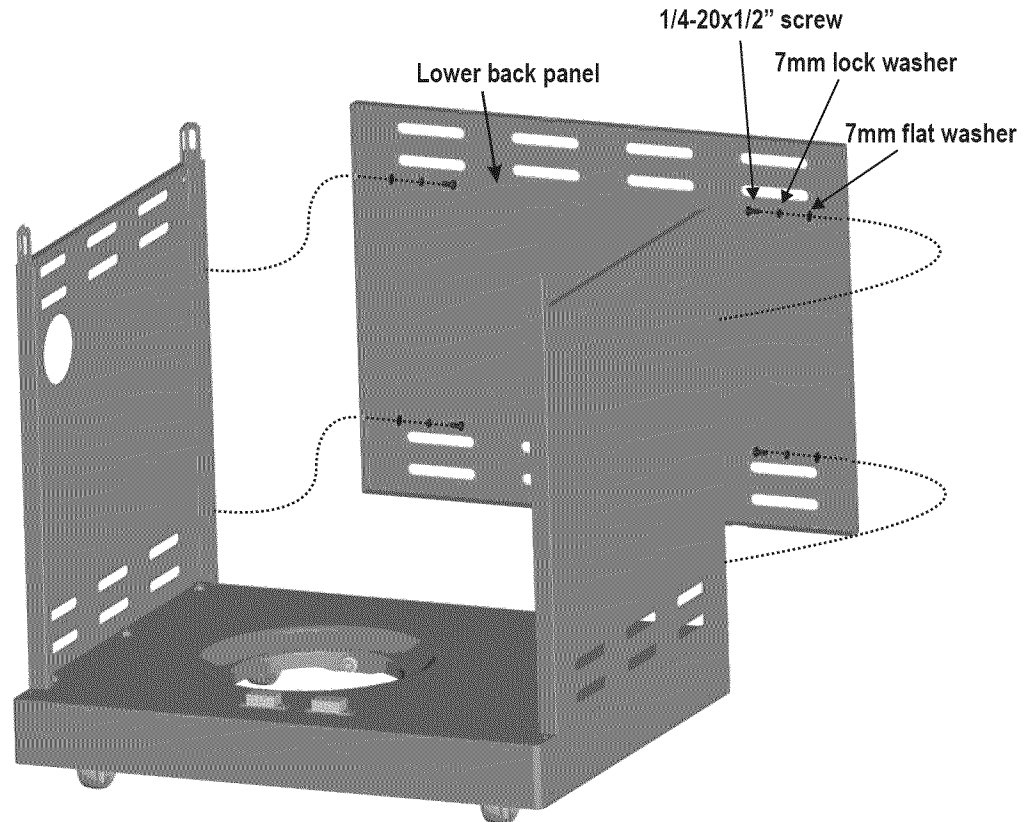

7mm flat washer  
Qty.4

**4**

This step requires two people to lift and position grill head onto cart. Carefully lower the grill head onto the cart, aligning slots at bottom of grill head with posts on cart side panels. Make sure the regulator hose is hanging outside the cart. Grill head must face open side of cart.

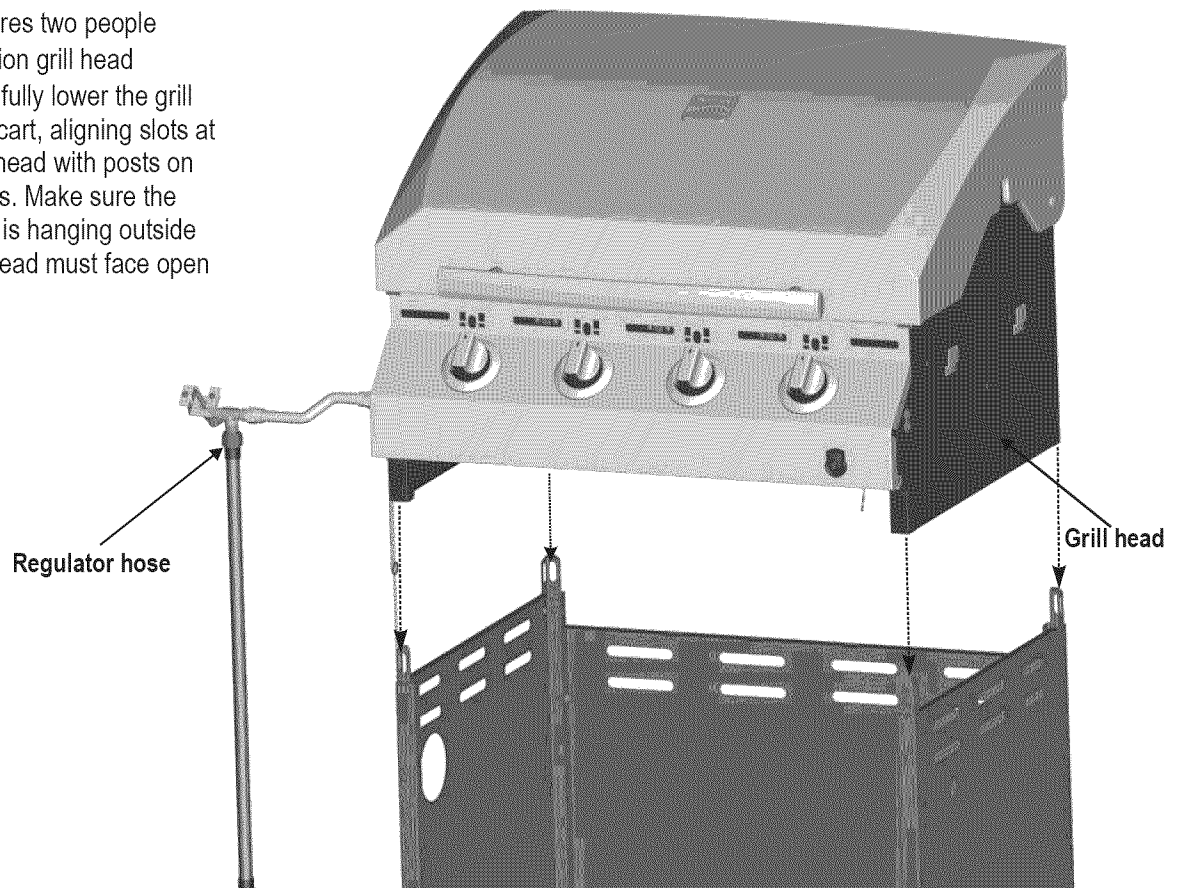

**5**

On back of grill, place upper back panel between side panels and above lower back panel. Secure upper back panel in lower holes using one 1/4-20x1½" screw, 7mm lock washer and 7mm flat washer on each side. Do not fully tighten screws until side shelf installation is complete in later steps.



1/4-20x1½" screw  
Qty.2



7mm Lock washer  
Qty.2



7mm flat washer  
Qty.2

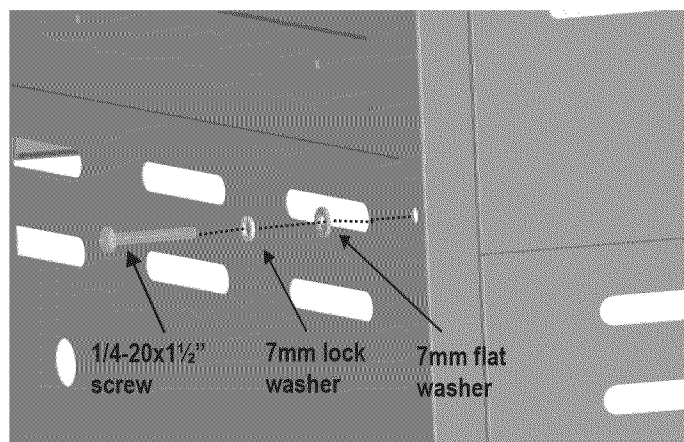
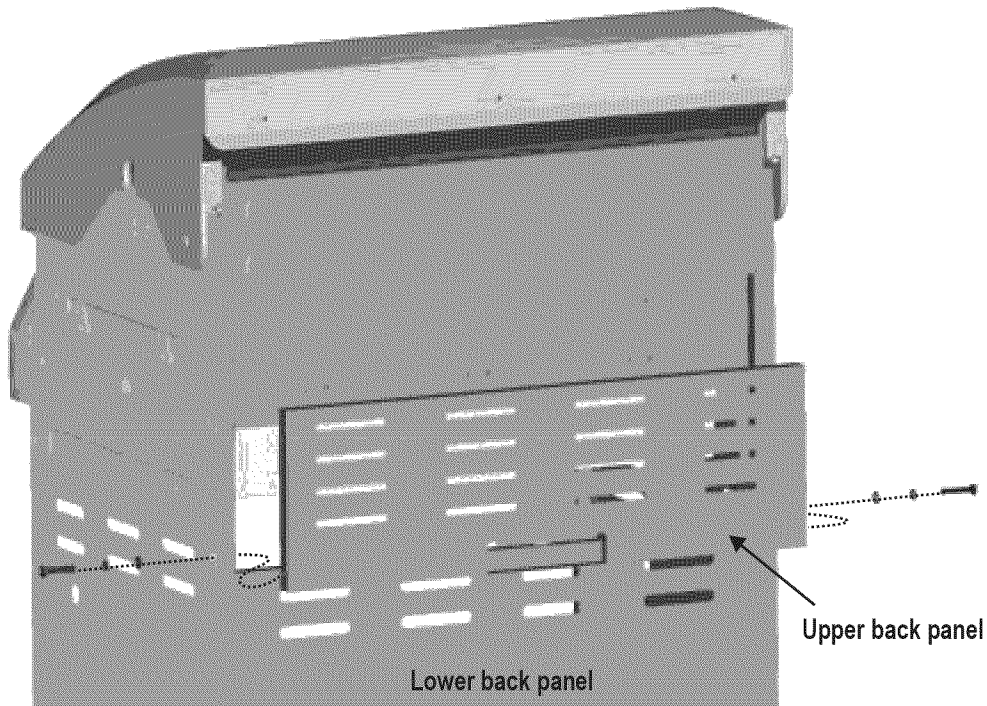

- 6** Insert flange on right side shelf into side shelf brackets on side of firebox. Attach right side shelf using three **1/4-20x3/4"** screws, **7mm** lock washers, **7mm** flat washers and **1/4"** nuts, shown **A**. Attach rear of shelf using one **1/4-20x1 1/2"** screw, **7mm** lock washer and **7mm** flat washer in lower hole, shown **B**. Attach front of shelf and fascia using one **#8x3/8"** self-tapping screw and large flat washer, shown **C**. Attach front of shelf and fascia using one **1/4-20x3/4"** screw, **7mm** lock washer, **7mm** flat washer and **1/4"** nut, shown **D/C**.

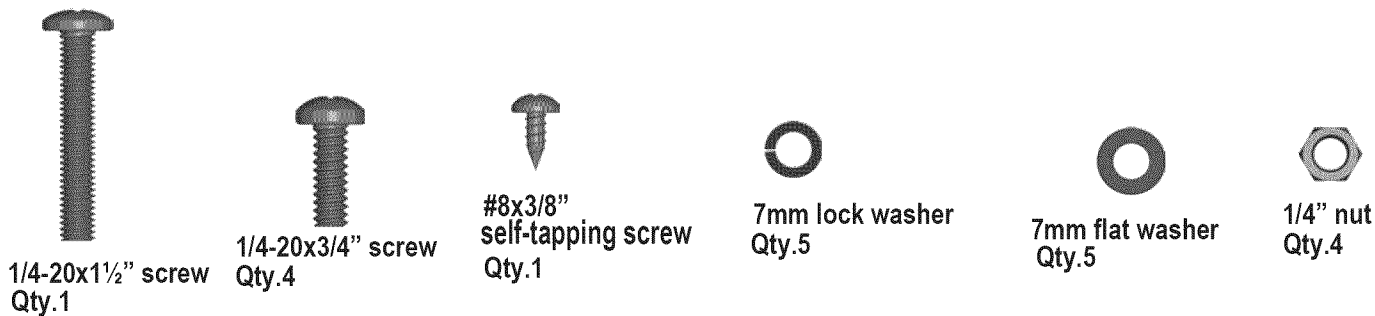

large flat washer Qty.1

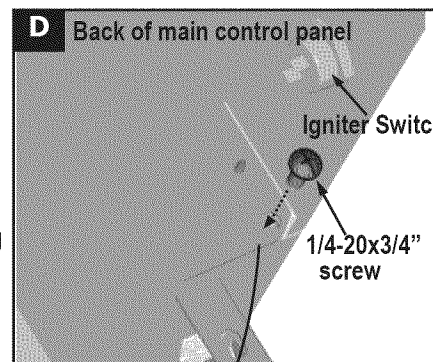
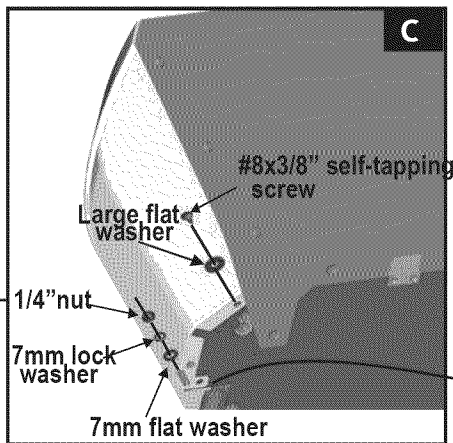
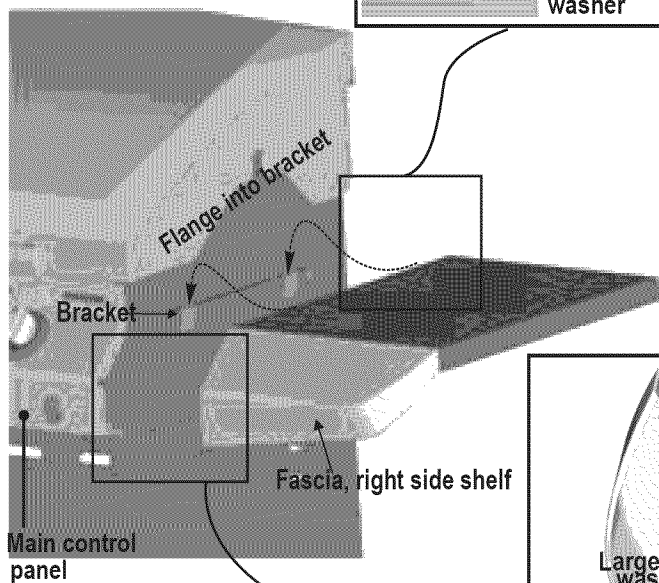
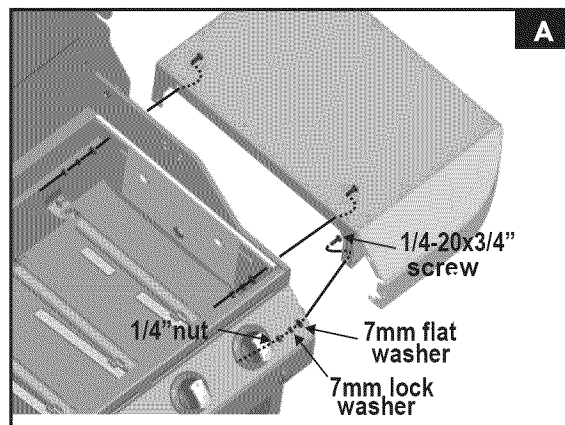
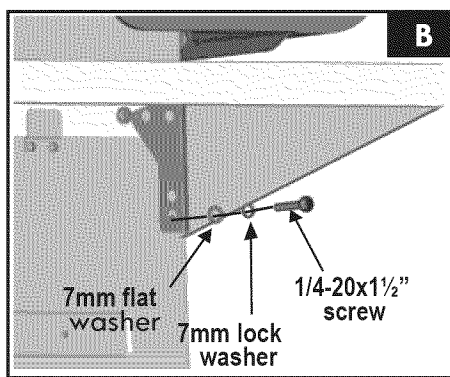

**7**

Insert flange on left sideburner shelf into side shelf brackets on side of firebox.

Attach left sideburner shelf using three  $1/4-20 \times 3/4$ " screws, 7mm lock washers, 7mm flat washers,  $1/4$ " nuts, shown **A**.

Attach rear of shelf using one  $1/4-20 \times 1\frac{1}{2}$ " screw, 7mm lock washer, and 7mm flat washer in lower hole, shown **B**.

Attach front of shelf and fascia using one  $\#8 \times 3/8$ " self-tapping screw and large flat washer, shown **C**.

Under main control panel, attach front of shelf and fascia using one  $1/4-20 \times 3/4$ " screw, 7mm lock washer, 7mm flat washer and  $1/4$ " nut, shown **D/E**.

Now you may fully tighten lower screws on upper back panel.

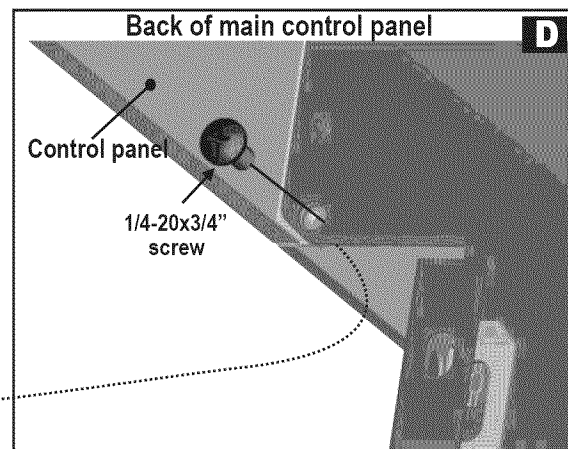
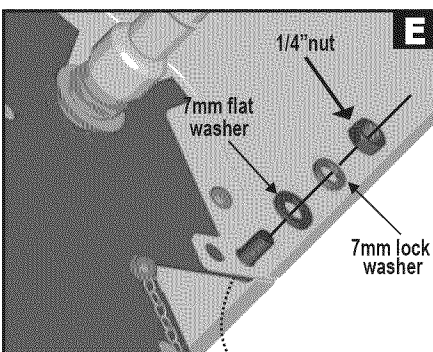
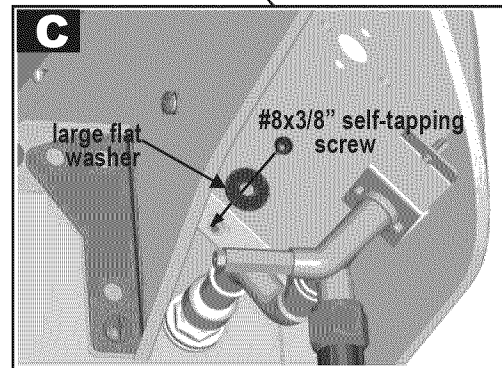
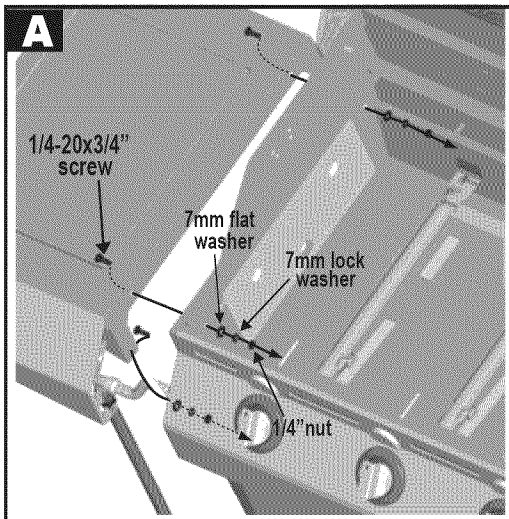
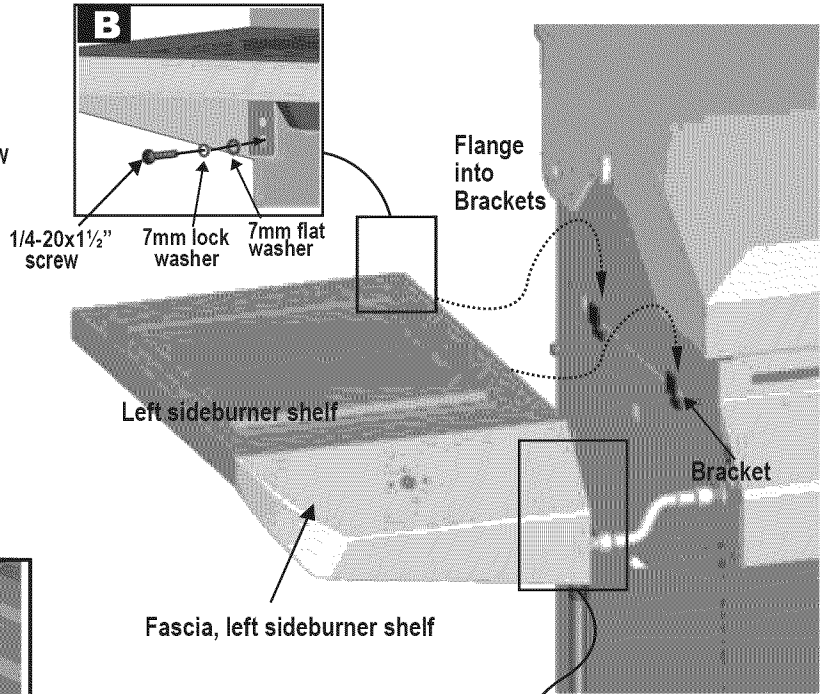
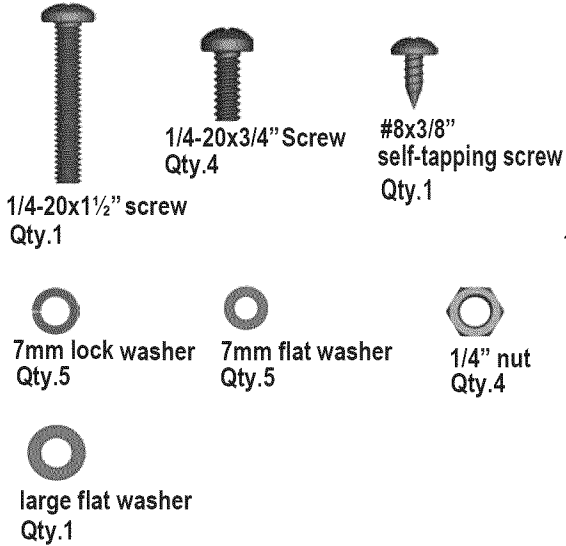

**8** First, remove the two screws and lock washers factory attached to the sideburner valve bracket. Position sideburner valve bracket beneath sideburner shelf fascia so that valve stem comes through larger center hole in fascia. Align the holes on valve bracket with left and right holes on fascia. Secure using lock washers and screws that were removed from bracket. Next, place sideburner bezel over valve stem on front side of fascia. Align small holes on bezel with upper and lower holes on fascia, making sure "OFF" is on the top. Attach using two #8-32x3/8" screws and 4mm lock washers. Press sideburner control knob onto valve stem.

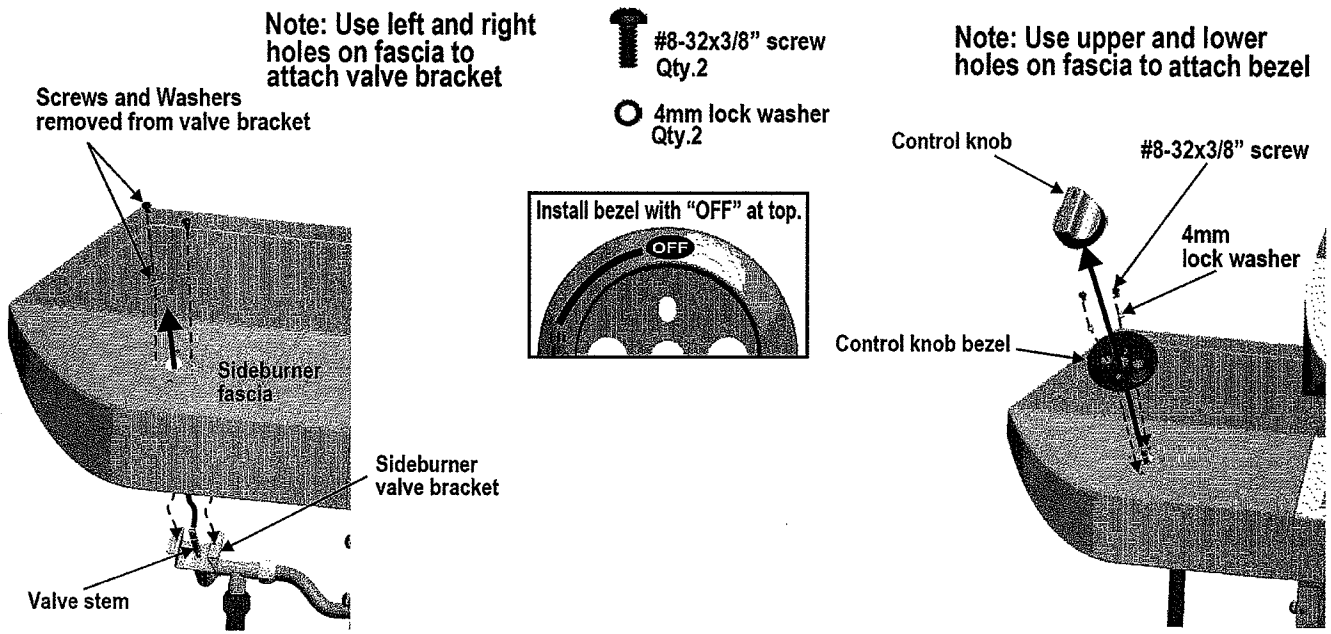

**9** Pull out the four knobs from control panel. Insert temperature gauge stem into the bigger hole above knob bezel, shown A. Make sure the gauge is pushed in as far as it will go, then push the gauge downward until it clips into the panel, as shown in B/C. Re-install the knobs.

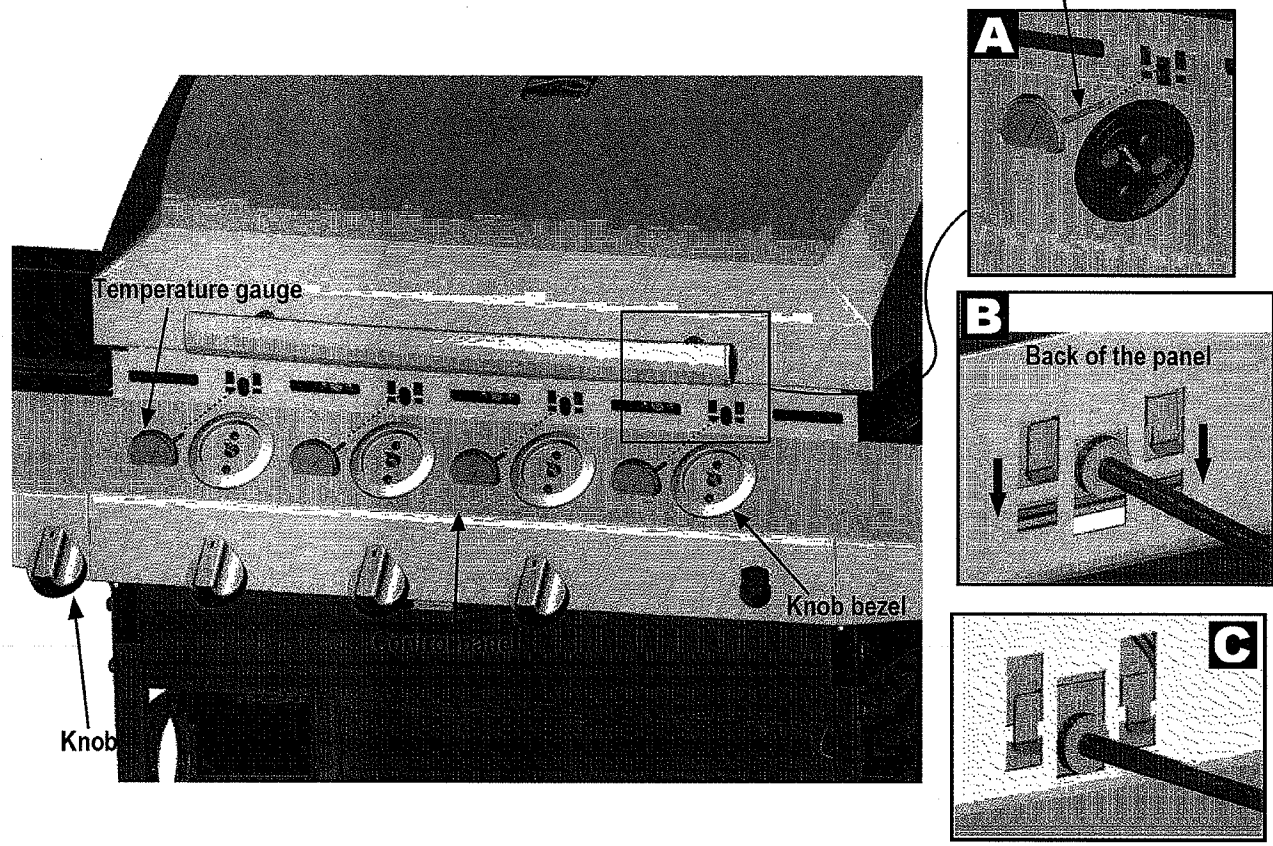

**10** Insert sideburner burner into left shelf. The stud on bottom of burner fits into rear small hole in sideburner drip pan on shelf, shown **A**. Secure burner to sideburner drip pan with one Wing nut, shown **B**. Make sure burner tube engages sideburner valve, shown **C**.

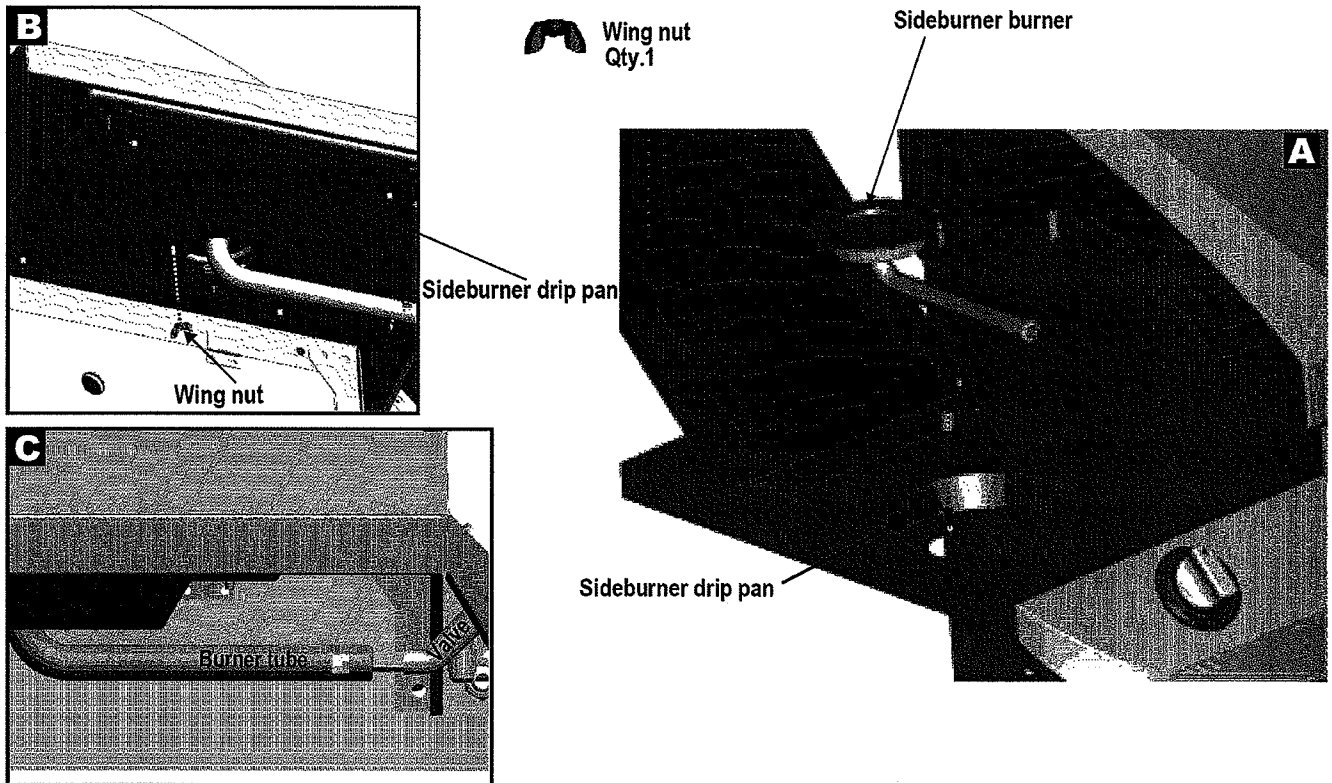

**11** Under sideburner shelf, attach sideburner ignitor wire to electrode, shown **A**. Place sideburner grate onto sideburner shelf, aligning grate legs with holes in shelf, shown **B**.

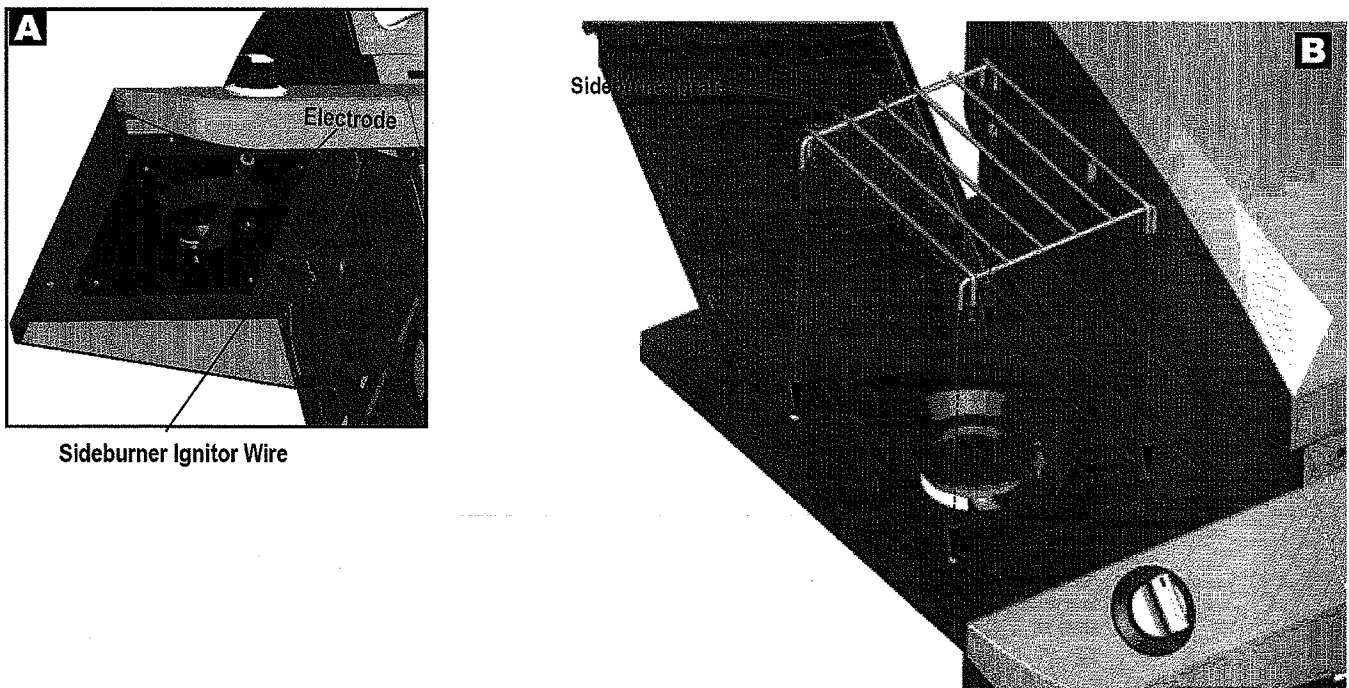

**12** Insert front brace under control panel and between cart side panels. Make sure door hinge pins are on the top side and facing the front. Secure using two 1/4-20x1 1/2" screws, 7mm lock washers, and 7mm flat washers on each side.

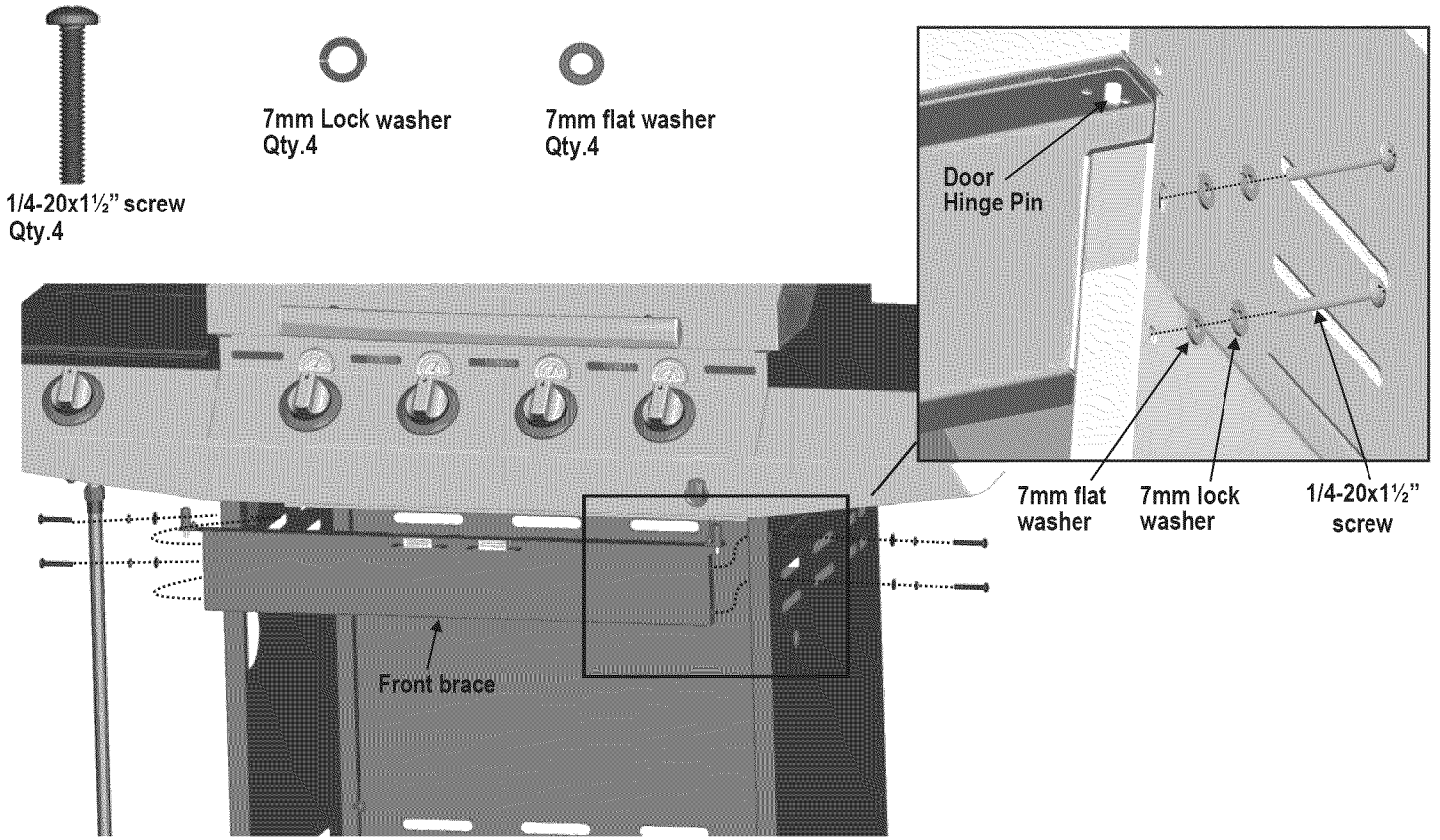

**13** Inside of cart, insert rear shield into left slot(#1) on top of lower back panel. Insert left grease tray rail into slot(#2) beneath grease tray opening in upper back panel, shown **A**. Attach front shield and left grease tray rail under front brace(#4 and #5) with two #8x3/8" self-tapping screws, shown **B**. Insert right grease tray rail into slot(#3) and attach it under front brace(#6) with one #8x3/8" self-tapping screws, shown **A/B**.

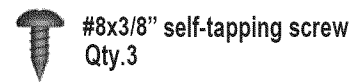
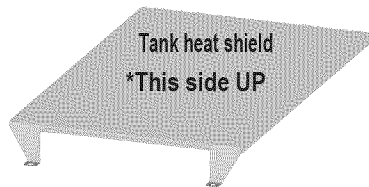
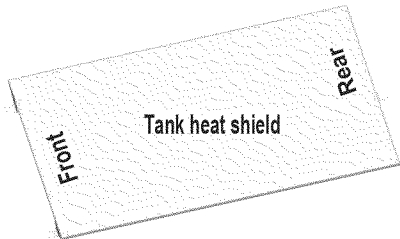

Note: some parts omitted for clarity of illustration

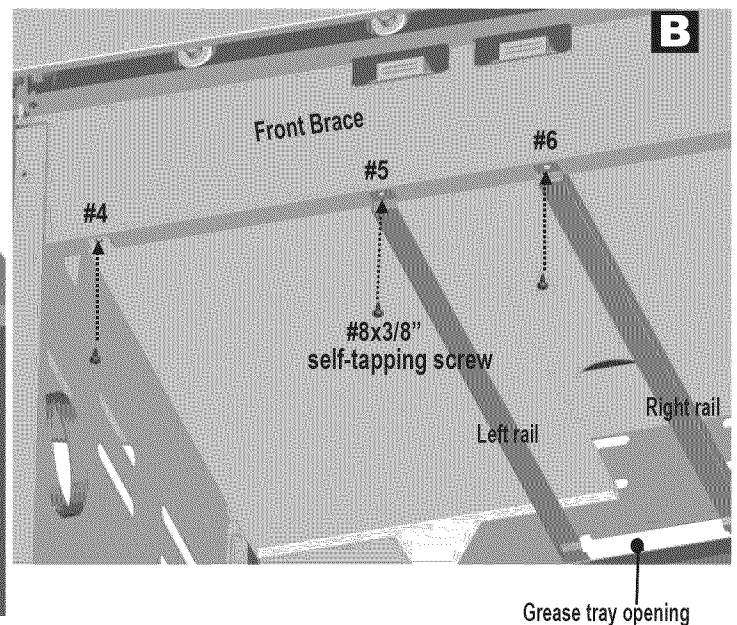
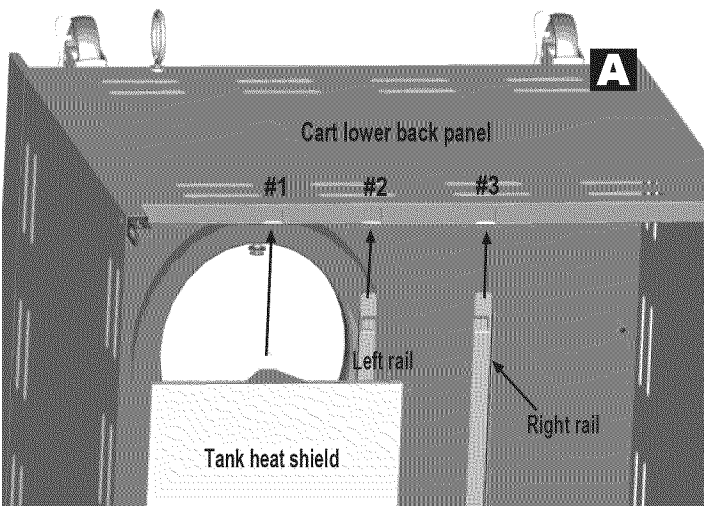

**14**

Insert hinge pin on bottom of doors into hole in bottom shelf. Press upper hinge pin in front brace, align hinge hole on top of door, and release hinge pin into door.

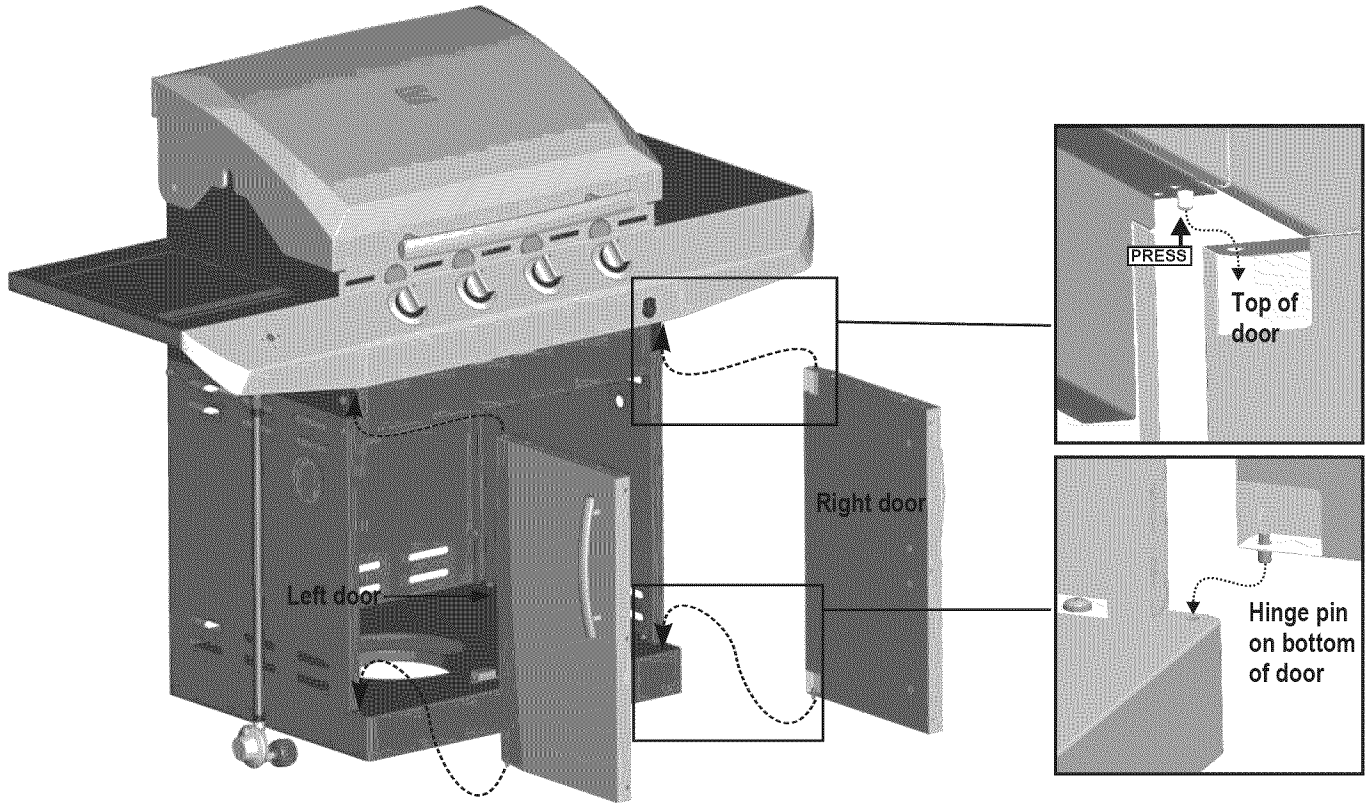
**15**

Connect each of the wires from the main burner electrodes, and sideburner electrode into the back of the Electronic Ignition Module. Total (5) connections. Connect the two wires{(a)and(b)} from the switch wiring harness into the back of the Electronic Ignition Module. Total (2) connections, shown **A**.

Release the cap and nut from electronic ignition module. Attach electronic ignition module to the cart right side panel with the nut, shown **B**. Insert AA battery into ignition module, negative (-) end first. Then put on the cap, shown **C**.

**NOTE: Switch terminals are larger than electrode terminals and should only be installed in location shown as (a), (b). Do not untie the wires while attaching.**

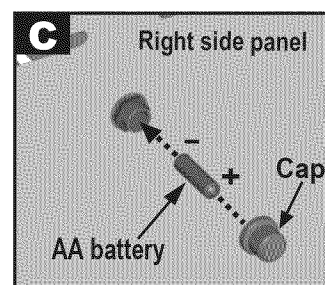
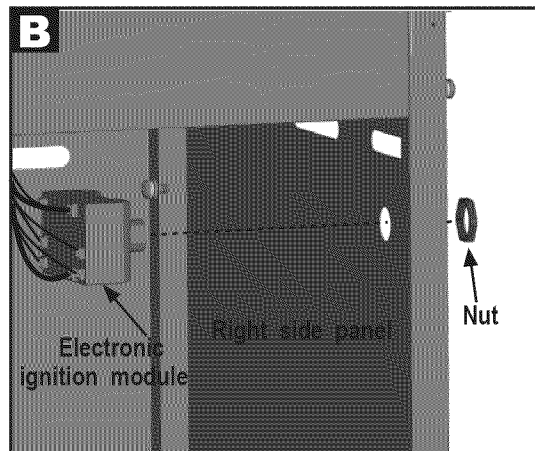
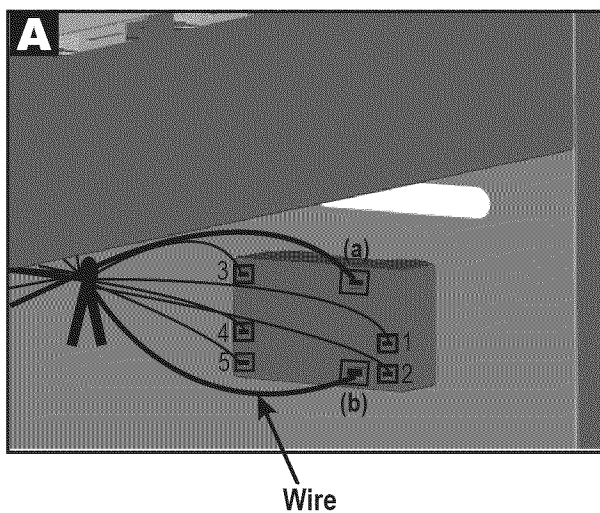

**16** Install heat diffusers by sliding one end of each heat diffuser into slots at front of firebox and resting opposite end on pins at back of firebox.

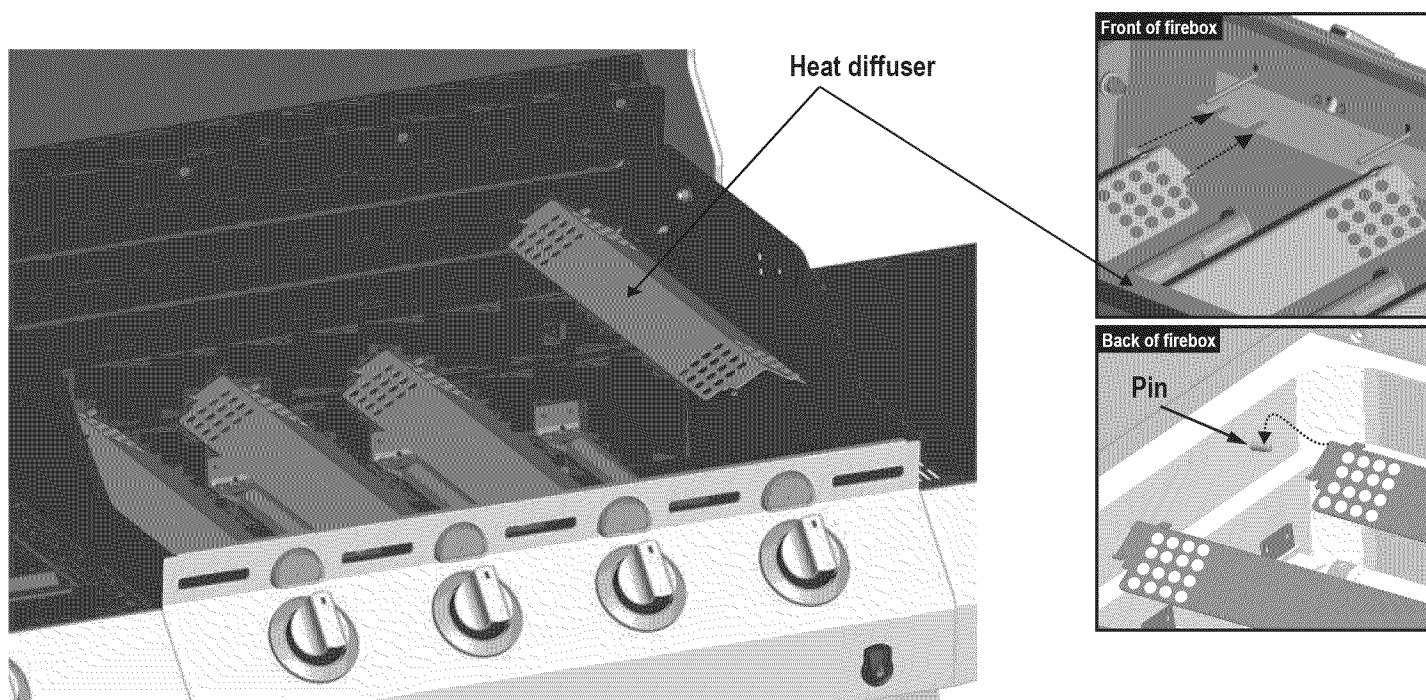

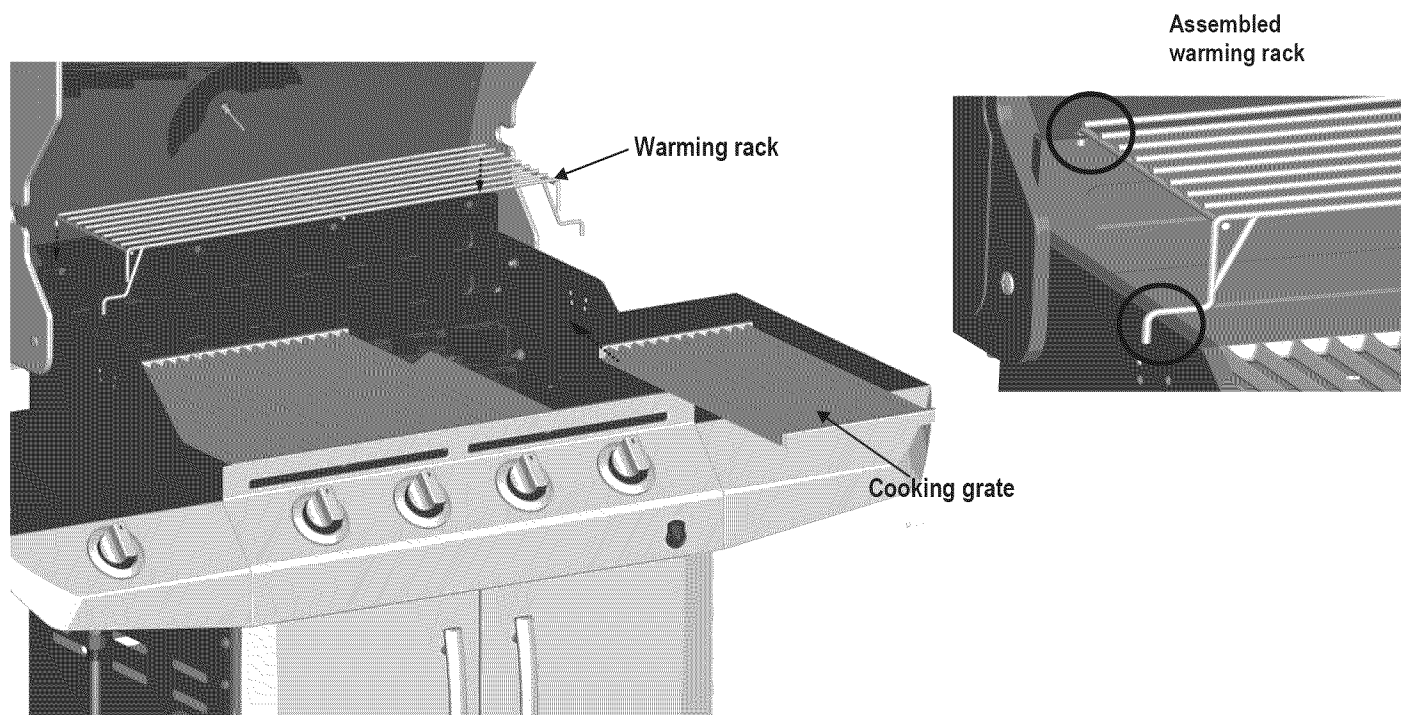

**17** Place cooking grates onto the firebox as shown. Insert the two wire ends at rear of warming rack into holes in back of firebox. Front wires of warming rack rest on sides of firebox.

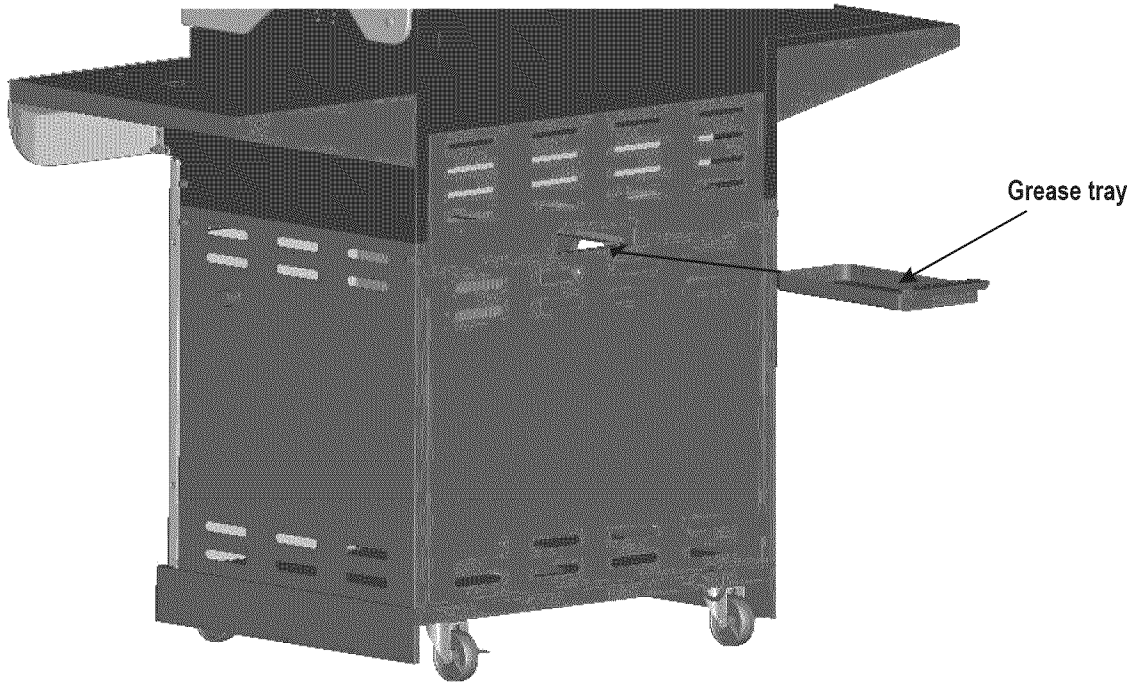

**18**

On back of grill, slide grease tray into opening in upper back panel.



	<b>CAUTION</b>	
<p>Failure to install grease tray will cause hot grease to drip from bottom of grill with risk of fire or property damage.</p>		

**19**

**LP CYLINDER IS SOLD SEPARATELY.** Fill and leak check the cylinder before attaching to grill and regulator (see Use & Care section). Once cylinder has been filled and leak checked, place cylinder into hole in bottom shelf. **Make sure cylinder valve is facing front of grill.** Secure cylinder with cylinder screw under bottom shelf. Insert regulator through large hole in left side panel. **See Use & Care section of this manual to perform the “Burner Flame Check” and for important safety instructions before using.**

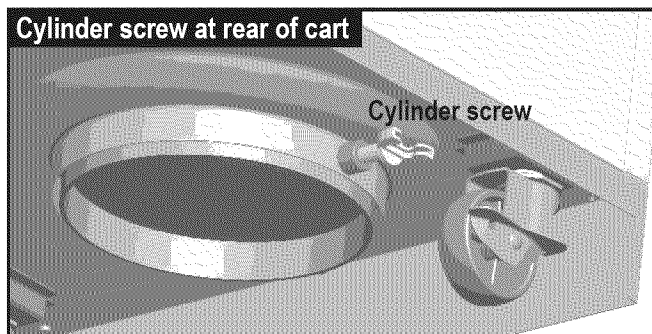

Always keep LP cylinders in upright position during use, transport, and storage.

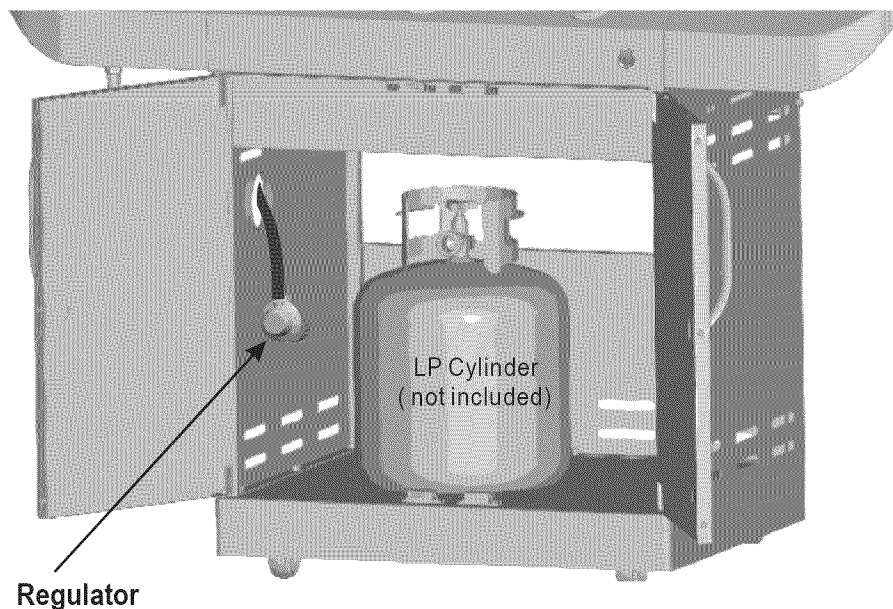

	<b>CAUTION</b>	
<p>Cylinder valve must face to front of cart once tank is attached. Failure to install cylinder correctly may allow gas hose to be damaged in operation, resulting in the risk of fire.</p>		

**EMERGENCIES:** If a gas leak cannot be stopped, or a fire occurs due to gas leakage, call the fire department.

Emergencies	Possible Cause	Prevention/Solution
Gas leaking from cracked/cut/burned hose.	<ul style="list-style-type: none"> <li>Damaged hose.</li> </ul>	<ul style="list-style-type: none"> <li>Turn off gas at LP cylinder or at source on natural gas systems. If anything but burned, replace valve/hose/regulator. If burned, discontinue use of product until a plumber has investigated cause and corrections are made.</li> </ul>
Gas leaking from LP cylinder.	<ul style="list-style-type: none"> <li>Mechanical failure due to rusting or mishandling.</li> </ul>	<ul style="list-style-type: none"> <li>Replace LP cylinder.</li> </ul>
Gas leaking from LP cylinder valve.	<ul style="list-style-type: none"> <li>Failure of cylinder valve from mishandling or mechanical failure.</li> </ul>	<ul style="list-style-type: none"> <li>Turn off LP cylinder valve. Return LP cylinder to gas supplier.</li> </ul>
Gas leaking between LP cylinder and regulator connection.	<ul style="list-style-type: none"> <li>Improper installation, connection not tight, failure of rubber seal.</li> </ul>	<ul style="list-style-type: none"> <li>Turn off LP cylinder valve. Remove regulator from cylinder and visually inspect rubber seal for damage. See LP Cylinder Leak Test and Connecting Regulator to the LP Cylinder.</li> </ul>
Fire coming through control panel.	<ul style="list-style-type: none"> <li>Fire in burner tube section of burner due to blockage.</li> </ul>	<ul style="list-style-type: none"> <li>Turn off control knobs and LP cylinder valve. Leave lid open to allow flames to die down. After fire is out and grill is cold, remove burner and inspect for spider nests or rust. See Natural Hazard and Cleaning the Burner Assembly pages.</li> </ul>
Grease fire or continuous excessive flames above cooking surface.	<ul style="list-style-type: none"> <li>Too much grease buildup in burner area.</li> </ul>	<ul style="list-style-type: none"> <li>Turn off control knobs and LP cylinder valve. Leave lid open to allow flames to die down. After cooling, clean food particles and excess grease from inside firebox area, grease tray, and other surfaces.</li> </ul>

**Troubleshooting**

Problem	Possible Cause	Prevention/Solution
<p>Burner(s) will not light using ignitor. (See Electronic Ignition Troubleshooting also)</p> <p><i>Continued on next page.</i></p>	<p><b>GAS ISSUES:</b></p> <ul style="list-style-type: none"> <li>Trying to light wrong burner.</li> <li>Burner not engaged with control valve.</li> <li>Obstruction in burner.</li> <li>No gas flow.</li> <li>Vapor lock at coupling nut to LP cylinder.</li> <li>Coupling nut and LP cylinder valve not fully connected.</li> </ul> <p><b>ELECTRICAL ISSUES:</b></p> <ul style="list-style-type: none"> <li>Electrode cracked or broken; "sparks at crack."</li> <li>Electrode tip not in proper position.</li> <li>Wire and/or electrode covered with cooking residue.</li> <li>Wires are loose or disconnected.</li> <li>Wires are shorting (sparking) between ignitor and electrode.</li> <li>Dead battery.</li> </ul>	<ul style="list-style-type: none"> <li>See instructions on control panel and in Use and Care section.</li> <li>Make sure valves are positioned inside of burner tubes.</li> <li>Ensure burner tubes are not obstructed with spider webs or other matter. See cleaning section of Use and Care.</li> <li>Make sure LP cylinder is not empty. If LP cylinder is not empty, refer to "Sudden drop in gas flow."</li> <li>For a grill equipped with the AUTO-CLEAN™ feature, make sure the AUTO-CLEAN™ valve is set to "Grill"</li> <li>Turn off knobs and disconnect coupling nut from LP cylinder. Reconnect and retry.</li> <li>Turn the coupling nut approximately one-half to three-quarters additional turn until solid stop. Tighten by hand only - do not use tools.</li> <li>Replace electrode(s).</li> </ul> <p>Main Burners:</p> <ul style="list-style-type: none"> <li>Tip of electrode should be pointing toward gas port opening on burner. The distance should be 1/8" to 1/4". Adjust if necessary.</li> </ul> <p>Sideburner:</p> <ul style="list-style-type: none"> <li>Tip of electrode should be pointing toward gas port opening on burner. The distance should be 1/8" to 3/16". Adjust if necessary.</li> <li>Clean wire and/or electrode with rubbing alcohol and clean swab.</li> <li>Reconnect wires or replace electrode/wire assembly.</li> <li>Replace ignitor wire/electrode assembly.</li> <li>Replace with a new AA-size alkaline battery.</li> </ul>



## Troubleshooting (continued)

Problem	Possible Cause	Prevention/Solution
Burner(s) will not light using ignitor. (See Electronic Ignition Troubleshooting also)	<b>ELECTRONIC IGNITION:</b> <ul style="list-style-type: none"> <li>No spark, no ignition noise.</li> <li>No spark, some ignition noise.</li> <li>Sparks, but not at electrode or at full strength.</li> </ul>	<ul style="list-style-type: none"> <li>See Section I of Electronic Ignition System.</li> <li>See Section II of Electronic Ignition System.</li> <li>See Section III of Electronic Ignition System.</li> </ul>
Burner(s) will not match light.	<ul style="list-style-type: none"> <li>See “<b>GAS ISSUES:</b>” on previous page.</li> <li>Match will not reach.</li> <li>Improper method of match-lighting.</li> </ul>	<ul style="list-style-type: none"> <li>Use long-stem match (fireplace match).</li> <li>See “Match-Lighting” section of Use and Care.</li> </ul>
Sudden drop in gas flow or low flame.	<ul style="list-style-type: none"> <li>Out of gas.</li> <li>Excess flow valve tripped.</li> <li>Vapor lock at coupling nut/LP cylinder connection.</li> </ul>	<ul style="list-style-type: none"> <li>Check for gas in LP cylinder.</li> <li>Turn off knobs, wait 30 seconds and light grill. If flames are still low, turn off knobs and LP cylinder valve. Disconnect regulator. Reconnect regulator and leak-test. Turn on LP cylinder valve, wait 30 seconds and then light grill.</li> <li>Turn off knobs and LP cylinder valve. Disconnect coupling nut from cylinder. Reconnect and retry.</li> </ul>
Flames blow out.	<ul style="list-style-type: none"> <li>High or gusting winds.</li> <li>Low on LP gas.</li> <li>Excess flow valve tripped.</li> </ul>	<ul style="list-style-type: none"> <li>Turn front of grill to face wind or increase flame height.</li> <li>Refill LP cylinder.</li> <li>Refer to “Sudden drop in gas flow” above.</li> </ul>
Flare-up.	<ul style="list-style-type: none"> <li>Grease buildup.</li> <li>Excessive fat in meat.</li> <li>Excessive cooking temperature.</li> </ul>	<ul style="list-style-type: none"> <li>Clean burners and inside of grill/firebox.</li> <li>Trim fat from meat before grilling.</li> <li>Adjust (lower) temperature accordingly.</li> </ul>
Persistent grease fire.	<ul style="list-style-type: none"> <li>Grease trapped by food buildup around burner system.</li> </ul>	<ul style="list-style-type: none"> <li>Turn knobs to OFF. Turn gas off at LP cylinder. Leave lid in position and let fire burn out. After grill cools, remove and clean all parts.</li> </ul>
Flashback... (fire in burner tube(s)).	<ul style="list-style-type: none"> <li>Burner and/or burner tubes are blocked.</li> </ul>	<ul style="list-style-type: none"> <li>Turn knobs to OFF. Clean burner and/or burner tubes. See burner cleaning section of Use and Care.</li> </ul>
Unable to fill LP cylinder.	<ul style="list-style-type: none"> <li>Some dealers have older fill nozzles with worn threads.</li> </ul>	<ul style="list-style-type: none"> <li>The worn nozzles don't have enough “bite” to engage the valve. Try a second LP dealer.</li> </ul>
One burner does not light from other burner(s).	<ul style="list-style-type: none"> <li>Grease buildup or food particles in end(s) of carryover tube(s).</li> </ul>	<ul style="list-style-type: none"> <li>Clean carry-over tube(s) with wire brush.</li> </ul>
<b>AUTO-CLEAN™</b> (If Equipped)	Possible Cause	Prevention/Solution
Timer does not work (Green light does not flash)	<ul style="list-style-type: none"> <li>Dead Battery</li> <li>Batteries installed incorrectly.</li> <li>Knob Position did not start the Clean Cycle</li> </ul>	<ul style="list-style-type: none"> <li>Replace Batteries</li> <li>Install batteries correctly.</li> <li>Push Knob in to start the clean cycle. (Green LED should begin to flash)</li> </ul>
No LED's will illuminate	<ul style="list-style-type: none"> <li>Dead Battery</li> </ul>	<ul style="list-style-type: none"> <li>Replace Batteries</li> </ul>
Red LED next to battery symbol is illuminated	<ul style="list-style-type: none"> <li>Low Battery Strength</li> </ul>	<ul style="list-style-type: none"> <li>Prepare to replace batteries (NOTE: Clean cycle will operate with a weak battery).</li> </ul>

## Troubleshooting - Electronic Ignition

Problem (Ignition)	Possible Cause	Check Procedure	Prevention/Solution
<p><b>SECTION I</b></p> <p>No sparks appear at any electrodes when Electronic Ignition Button is pressed; <b>no noise</b> can be heard from spark module.</p>	<ul style="list-style-type: none"> <li>• Battery not installed properly.</li> <li>• Dead battery.</li> <li>• Button assembly not installed properly.</li> <li>• Faulty spark module.</li> </ul>	<ul style="list-style-type: none"> <li>• Check battery orientation.</li> <li>• Has battery been used previously?</li> <li>• Check to insure threads are properly engaged. Button should travel up and down without binding.</li> <li>• If no sparks are generated with new battery and good wire connections, module is faulty.</li> </ul>	<ul style="list-style-type: none"> <li>• Install battery (make sure that “+” and “-” connectors are oriented correctly, with “+” end up and “-” end down.)</li> <li>• Replace battery with new AA-size alkaline battery.</li> <li>• Unscrew button cap assembly and reinstall, making sure threads are aligned and engaged fully.</li> <li>• Replace spark module assembly.</li> </ul>
<p><b>SECTION II</b></p> <p>No sparks appear at any electrodes when Electronic Ignition Button is pressed; noise <b>can</b> be heard from spark module.</p>	<ul style="list-style-type: none"> <li>• Output lead connections not connected.</li> </ul>	<ul style="list-style-type: none"> <li>• Are output connections on and tight?</li> </ul>	<ul style="list-style-type: none"> <li>• Remove and reconnect all output connections at module and electrodes.</li> </ul>
<p><b>SECTION III</b></p> <p>Sparks are present but not at all electrodes and/or not at full strength</p>	<ul style="list-style-type: none"> <li>• Output lead connections not connected.</li> <li>• Arcing to grill away from burner(s).</li> <li>• Weak battery.</li> <li>• Electrodes are wet.</li> <li>• Electrodes cracked or broken “sparks at crack”.</li> </ul>	<ul style="list-style-type: none"> <li>• Are output connections on and tight?</li> <li>• If possible, observe grill in dark location. Operate ignition system and look for arcing between output wires and grill frame.</li> <li>• All sparks present but weak or at slow rate.</li> <li>• Has moisture accumulated on electrode and/or in burner ports?</li> <li>• Inspect electrodes for cracks.</li> </ul>	<ul style="list-style-type: none"> <li>• Remove and reconnect all output connections at module and electrodes.</li> <li>• If sparks are observed other than from burner(s), wire insulation may be damaged. Replace wires.</li> <li>• Replace battery with a new AA-size alkaline battery.</li> <li>• Use paper towel to remove moisture.</li> <li>• Replace cracked or broken electrodes.</li> </ul>







Please register your product online at:

**www.charbroil.com/register**

(If you register online, you do not need to send in this registration card.)

PLEASE FILL OUT THIS CARD AND ATTACH A COPY OF YOUR SALES RECEIPT. RETURN IT WITHIN 10 DAYS OF PURCHASE. FAILURE TO RETURN MAY AFFECT YOUR WARRANTY COVERAGE. FOR WARRANTY SERVICE PROOF OF PURCHASE WILL BE REQUIRED. THIS WARRANTY IS NON-TRANSFERABLE.

LENE ESTA TARJETA Y DEVUELVALA DENTRO DE LOS 10 DIAS DE LA COMPRA. SI NO LA DEVUELVE, PUEDE VERSE AFECTADA SU COBERTURA DE GARANTIA. PARA EL SERVICIO DE GARANTIA ES NECESARIO QUE PRESENTE SU COMPROBANTE DE COMPRA. CONSERVE LA FACTURA. ESTA GARANTIA ES INTRANSFERIBLE.

VEUILLEZ COMPLETER CETTE CARTE ET LA RETOURNER DANS LES 10 JOURS SUIVANT L'ACHAT. LA COUVERTURE DE VOTRE GARANTIE POURRAIT EN ETRE AFFECTEE SI VOUS NE LE FAITES PAS. POUR OBTENIR LE SERVICE SOUS GARANTIE, UNE PREUVE D'ACHAT DOIT ETRE PRESENTEE. VEUILLEZ CONSERVER VOTRE FACTURE. LA PRESENTE GARANTIE N'EST PAS TRANSFERABLE.

1 First Name/Nombre/Prénom Initial/Inicial/Initiale Last Name/Apellido/Nom de famille

Address (number and street)/Dirección (número y calle)/Adresse (numéro et rue) Apt Number/Nº de apart./Nº d'appt.

City/Ciudad/Ville State/Estado/Province Zip Code/Código Zip/Code postal

2 E-mail Address/Dirección de correo electrónico/Adresse électronique

If you voluntarily provide us with your email address, you give us permission to use your email address to send you offers that may interest you. Si nos informa voluntariamente su dirección de correo electrónico, nos da permiso para usarlo a fin de enviarle ofertas que pueden interesarle. Si vous choisissez de nous fournir votre adresse électronique, vous nous donnez la permission de l'utiliser pour vous faire part d'offres spéciales susceptibles de vous intéresser.

(Example: your name @ your host.com) (Ejemplo: su nombre@su host.com) (Exemple : votre nom@votre hôte.com)

10 Attach copy of your sales receipt here  
Adjunte aquí la copia de su recibo de compra  
Veillez attacher une copie de votre reçu ici.

3 Phone Number/Número telefónico/Numéro de téléphone

6 Date of Purchase/Fecha de compra/Date de l'achat

4 **IMPORTANT!;IMPORTANTE!;IMPORTANT!**  
Write Serial Number and Model Number in spaces below.  
Escriba en los espacios de abajo el número de serie y el número de modelo.  
Inscrivez le numéro de série et le numéro de modèle dans les espaces ci-dessous.

7 Store Name/Nombre de la tienda/Nom du magasin

8 Purchase Price/Precio de compra/Prix d'achat

\$ \_\_\_\_\_ .00

5 Your Gender/Sexo/Sexe : 1.  Male/Masculino/Masculin 2.  Female/Femenino/Féminin

9 Which product are you registering?

¿Qué producto está registrando?

Quel produit enregistrez-vous?

1.  Gas Grill/Parrilla a gas/Gril au gaz
2.  Electric Grill/Parrilla eléctrica/Gril électrique
3.  Smoker/Ahumador/Fumoir
4.  Charcoal Grill/Parrilla a carbón/Barbecue au charbon
5.  Charcoal Smoker/Ahumador a carbón/Fumoir au charbon
6.  Outdoor Fireplace/Chimenea para exteriores/Foyer extérieur
7.  Cooker/Fryer / Cocina/freidora / Cuiseur/Friteuse
8.  Other/Otro/Autre

Mail to: / Envíelo a:

Warranty Registration Department  
P.O. Box 1240  
Columbus, GA 31902-1240

Thank you for completing this questionnaire. Your answers will help us and other companies reach you with offers that may interest you. If you prefer not to receive these offers, please check here .

Gracias por completar este cuestionario. Sus respuestas nos ayudarán, a nosotros y a otras compañías, a llegar a usted con ofertas que puedan resultarle de interés. Si prefiere no recibir estas ofertas, por favor marque aquí .

Merci d'avoir bien voulu remplir ce questionnaire. Vos réponses nous aideront et aideront d'autres compagnies à vous communiquer des offres spéciales susceptibles de vous intéresser. Si vous préférez ne pas recevoir d'informations concernant ces offres spéciales, veuillez cocher ici .

# Thank you for recent purchase from Char-Broil!

Register your product to receive a special offer  
[www.charbroil.com/register](http://www.charbroil.com/register)

Check out these great features on our website!

- Product information
- Grilling accessories
- Replacement parts
- Reliable customer support
- Delicious recipes
- Grilling tips from expert chefs
- Exciting events and promotions
- Share your grilling secrets
- Browse the on-line store
- And much more!

**Char-Broil**<sup>®</sup>

[www.charbroil.com](http://www.charbroil.com)  
For all your grilling needs!