

# Operator's Manual

# CRAFTSMAN

## 10 in. TABLE SAW

Model No.  
315.218290

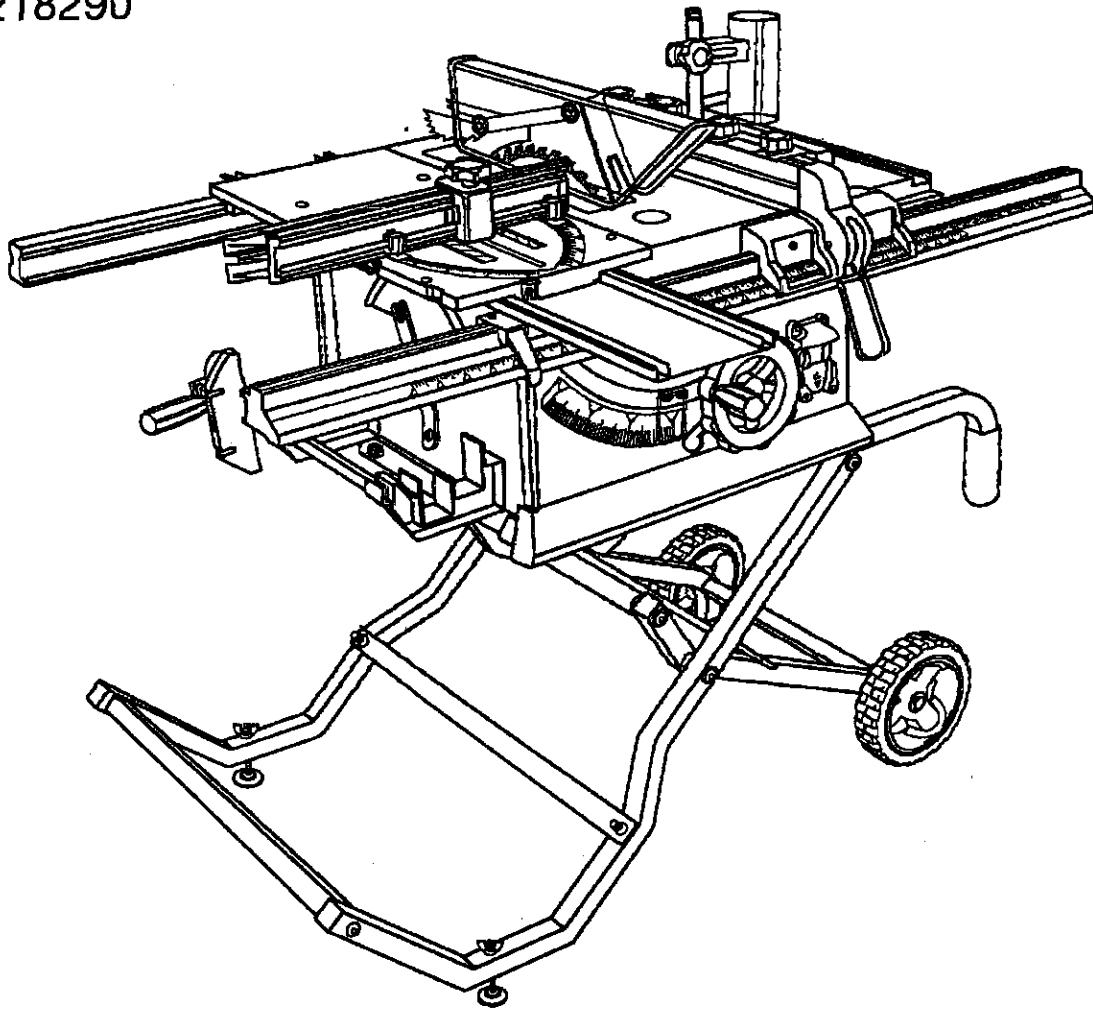

**WARNING:** To reduce the risk of injury, the user must read and understand the operator's manual before using this product.

Customer Help Line: 1-800-932-3188

Sears, Roebuck and Co., 3333 Beverly Rd., Hoffman Estates, IL 60179 USA  
Visit the Craftsman web page: [www.sears.com/craftsman](http://www.sears.com/craftsman)

983000-693  
7-15-05



## TABLE OF CONTENTS

Warranty .....	2
Introduction .....	2
General Safety Rules .....	3-4
Specific Safety Rules.....	4-5
Symbols.....	6-7
Electrical .....	8
Glossary of Terms.....	9
Features.....	10-13
Tools Needed .....	13
Loose Parts .....	14-15
Assembly.....	16-22
Operation.....	22-39
Adjustments .....	40-44
Maintenance.....	45
Accessories .....	46
Troubleshooting.....	46-47
Exploded View.....	48-57
Parts Ordering/Service .....	Back Page

## WARRANTY

### ONE YEAR FULL WARRANTY ON CRAFTSMAN TOOL

If this Craftsman tool fails due to a defect in material or workmanship within one year from the date of purchase, Call **1-800-4-MY-HOME®** to arrange for free repair. If this tool is used for commercial or rental purposes, this warranty will apply for only ninety days from the date of purchase. This warranty applies only while this product is in the United States.

This warranty gives you specific legal rights, and you may also have other rights which vary from state to state.

Sears, Roebuck and Co., Dept. 817WA, Hoffman Estates, IL 60179

## INTRODUCTION

This tool has many features for making its use more pleasant and enjoyable. Safety, performance, and dependability have been given top priority in the design of this product making it easy to maintain and operate.

# GENERAL SAFETY RULES

**⚠ WARNING:** Read and understand all instructions. Failure to follow all instructions listed below, may result in electric shock, fire and/or serious personal injury.

## READ ALL INSTRUCTIONS

- **KNOW YOUR POWER TOOL.** Read the operator's manual carefully. Learn the saw's applications and limitations as well as the specific potential hazards related to this tool.
- **GUARD AGAINST ELECTRICAL SHOCK BY PREVENTING BODY CONTACT WITH GROUNDED SURFACES.** For example, pipes, radiators, ranges, refrigerator enclosures.
- **KEEP GUARDS IN PLACE** and in good working order.
- **REMOVE ADJUSTING KEYS AND WRENCHES.** Form habit of checking to see that keys and adjusting wrenches are removed from tool before turning it on.
- **KEEP WORK AREA CLEAN.** Cluttered areas and benches invite accidents. **DO NOT** leave tools or pieces of wood on the saw while it is in operation.
- **DO NOT USE IN DANGEROUS ENVIRONMENTS.** Do not use power tools in damp or wet locations or expose to rain. Keep the work area well lit.
- **KEEP CHILDREN AND VISITORS AWAY.** All visitors should wear safety glasses and be kept a safe distance from work area. Do not let visitors contact tool or extension cord while operating.
- **MAKE WORKSHOP CHILDPROOF** with padlocks and master switches, or by removing starter keys.
- **DON'T FORCE TOOL.** It will do the job better and safer at the feed rate for which it was designed.
- **USE RIGHT TOOL.** Don't force the tool or attachment to do a job it was not designed for. Don't use it for a purpose not intended.
- **USE THE PROPER EXTENSION CORD.** Make sure your extension cord is in good condition. Use only a cord heavy enough to carry the current your product will draw. An undersized cord will cause a drop in line voltage resulting in loss of power and overheating. A wire gauge size (A.W.G.) of at least 14 is recommended for an extension cord 25 feet or less in length. If in doubt, use the next heavier gauge. The smaller the gauge number, the heavier the cord.
- **DRESS PROPERLY.** Do not wear loose clothing, gloves, neckties, or jewelry. They can get caught and draw you into moving parts. Rubber gloves and nonskid footwear are recommended when working outdoors. Also wear protective hair covering to contain long hair.
- **ALWAYS WEAR SAFETY GLASSES WITH SIDE SHIELDS.** Everyday eyeglasses have only impact-resistant lenses, they are **NOT** safety glasses.
- **SECURE WORK.** Use clamps or a vise to hold work when practical. It's safer than using your hand and frees both hands to operate tool.
- **DON'T OVERREACH.** Keep proper footing and balance at all times.
- **MAINTAIN TOOLS WITH CARE.** Keep tools sharp and clean for better and safer performance. Follow instructions for lubricating and changing accessories.
- **DISCONNECT TOOLS.** When not in use, before servicing, or when changing attachments, blades, bits, cutters, etc., all tools should be disconnected.
- **AVOID ACCIDENTAL STARTING.** Be sure switch is off when plugging in any tool.
- **USE RECOMMENDED ACCESSORIES.** Consult the operator's manual for recommended accessories. The use of improper accessories may risk injury.
- **NEVER STAND ON TOOL.** Serious injury could occur if the tool is tipped or if the cutting tool is unintentionally contacted.
- **CHECK DAMAGED PARTS.** Before further use of the tool, a guard or other part that is damaged should be carefully checked to determine that it will operate properly and perform its intended function. Check for alignment of moving parts, binding of moving parts, breakage of parts, mounting and any other conditions that may affect its operation. A guard or other part that is damaged must be properly repaired or replaced by an authorized service center to avoid risk of personal injury.
- **USE THE RIGHT DIRECTION OF FEED.** Feed work into a blade or cutter against the direction of rotation of blade or cutter only.
- **NEVER LEAVE TOOL RUNNING UNATTENDED. TURN THE POWER OFF.** Don't leave tool until it comes to a complete stop.
- **PROTECT YOUR LUNGS.** Wear a face or dust mask if the cutting operation is dusty.
- **PROTECT YOUR HEARING.** Wear hearing protection during extended periods of operation.
- **DO NOT ABUSE CORD.** Never yank cord to disconnect from receptacle. Keep cord from heat, oil, and sharp edges.
- **USE OUTDOOR EXTENSION CORDS.** When tool is used outdoors, use only extension cords with approved ground connection that are intended for use outdoors and so marked.
- **ALWAYS KEEP THE BLADE GUARD AND RIVING KNIFE/SPREADER/SPLITTER IN PLACE** and in working order.
- **KEEP BLADES CLEAN, SHARP, AND WITH SUFFICIENT SET.** Sharp blades minimize stalling and kickback.
- **KEEP HANDS AWAY FROM CUTTING AREA.** Keep hands away from blades. Do not reach underneath

## GENERAL SAFETY RULES

work or around or over the blade while blade is rotating. Do not attempt to remove cut material when blade is moving.

- **BLADE COASTS AFTER BEING TURNED OFF.**
- **NEVER USE IN AN EXPLOSIVE ATMOSPHERE.** Normal sparking of the motor could ignite fumes.
- **INSPECT TOOL CORDS PERIODICALLY.** If damaged, have repaired by a qualified service technician at an authorized service facility. The conductor with insulation having an outer surface that is green with or without yellow stripes is the equipment-grounding conductor. If repair or replacement of the electric cord or plug is necessary, do not connect the equipment-grounding conductor to a live terminal. Repair or replace a damaged or worn cord immediately. Stay constantly aware of cord location and keep it well away from the rotating blade.
- **INSPECT EXTENSION CORDS PERIODICALLY** and replace if damaged.
- **GROUND ALL TOOLS.** If tool is equipped with three-prong plug, it should be plugged into a three-hole electrical receptacle.
- **CHECK WITH A QUALIFIED ELECTRICIAN** or service personnel if the grounding instructions are not completely understood or if in doubt as to whether the tool is properly grounded.
- **USE ONLY CORRECT ELECTRICAL DEVICES:** 3-wire extension cords that have 3-prong grounding plugs and 3-pole receptacles that accept the tool's plug.
- **DO NOT MODIFY** the plug provided. If it will not fit the outlet, have the proper outlet installed by a qualified electrician.
- **KEEP TOOL DRY, CLEAN, AND FREE FROM OIL AND GREASE.** Always use a clean cloth when clean-

ing. Never use brake fluids, gasoline, petroleum-based products, or any solvents to clean tool.

- **STAY ALERT AND EXERCISE CONTROL.** Watch what you are doing and use common sense. Do not operate tool when you are tired. Do not rush.
- **DO NOT USE TOOL IF SWITCH DOES NOT TURN IT ON AND OFF.** Have defective switches replaced by an authorized service center.
- **USE ONLY CORRECT BLADES.** Do not use blades with incorrect size holes. Never use blade washers or blade bolts that are defective or incorrect. The maximum blade capacity of your saw is 10 in. (254 mm).
- **BEFORE MAKING A CUT, BE SURE ALL ADJUSTMENTS ARE SECURE.**
- **BE SURE BLADE PATH IS FREE OF NAILS.** Inspect for and remove all nails from lumber before cutting.
- **NEVER TOUCH BLADE** or other moving parts during use.
- **NEVER START A TOOL WHEN ANY ROTATING COMPONENT IS IN CONTACT WITH THE WORKPIECE.**
- **DO NOT OPERATE A TOOL WHILE UNDER THE INFLUENCE OF DRUGS, ALCOHOL, OR ANY MEDICATION.**
- **WHEN SERVICING** use only identical replacement parts. Use of any other parts may create a hazard or cause product damage.
- **USE ONLY RECOMMENDED ACCESSORIES** listed in this manual or addendums. Use of accessories that are not listed may cause the risk of personal injury. Instructions for safe use of accessories are included with the accessory.
- **DOUBLE CHECK ALL SETUPS.** Make sure blade is tight and not making contact with saw or workpiece before connecting to power supply.

## SPECIFIC SAFETY RULES

- **GUARD AGAINST KICKBACK.** Kickback occurs when the blade stalls rapidly and workpiece is driven back towards the operator. It can pull your hand into the blade resulting in serious personal injury. Stay out of blade path and turn switch off immediately if blade binds or stalls.
- **USE RIP FENCE.** Always use a fence or straight edge guide when ripping.
- **SUPPORT LARGE PANELS.** To minimize risk of blade pinching and kickback, always support large panels.
- **REMOVE ALL FENCES AND AUXILIARY TABLES** before transporting saw. Failure to do so can result in an accident causing possible serious personal injury.
- **ALWAYS USE BLADE GUARD, RIVING KNIFE/SREADER/SPLITTER, AND ANTI-KICKBACK PAWLS** on all "through-sawing" operations. Through-

sawing operations are those in which the blade cuts completely through the workpiece as in ripping or cross cutting. Keep the blade guard down, the anti-kickback pawls down, and the riving knife/spreader/splitter properly aligned to the saw blade.

- **ALWAYS SECURE WORK** firmly against rip fence, miter fence, or miter gauge.
- **ALWAYS USE A PUSH STICK FOR RIPPING NARROW STOCK.** A push stick is a device used to push a workpiece through the blade instead of using your hands. Size and shape can vary but the push stick must always be narrower than the workpiece to prevent the push stick from contacting the saw blade. When ripping narrow stock, always use a push stick, so your hand does not come close to the saw blade. Use a featherboard and push blocks for non-through cuts.

## SPECIFIC SAFETY RULES

- **NEVER** perform any operation "freehand" which means using only your hands to support or guide the workpiece. Always use either the rip fence or miter fence to position and guide the work.
  - **NEVER** stand or have any part of your body in line with the path of the saw blade.
  - **NEVER** reach behind, over, or within three inches of the blade or cutter with either hand for any reason.
  - **MOVE THE RIP FENCE** out of the way when cross cutting.
  - **NEVER** use rip fence as cutoff gauge when cross cutting.
  - **NEVER** attempt to free a stalled saw blade without first turning the saw **OFF** and disconnecting the saw from the power source.
  - **PROVIDE ADEQUATE SUPPORT** to the rear and sides of the saw table for wide or long work pieces. Use a sturdy "outrigger" support if a table extension more than 24 inches long is attached to the saw.
  - **AVOID KICKBACKS** (work thrown back toward you) by:
    - a) Keeping blade sharp.
    - b) Keeping rip fence parallel to the saw blade.
    - c) Keeping riving knife/spreader/splitter, anti-kickback pawls, and blade guard in place and operating.
    - d) Not releasing the work before it is pushed all the way past the saw blade using a push stick.
    - e) Not ripping work that is twisted or warped or does not have a straight edge to guide along the fence.
  - **AVOID AWKWARD OPERATIONS AND HAND POSITIONS** where a sudden slip could cause your hand to move into the cutting tool.
  - **USE ONLY RECOMMENDED ACCESSORIES** listed in this manual or addendums. Use of accessories that are not listed may cause the risk of personal injury. Instructions for safe use of accessories are included with the accessory.
  - **MAKE SURE THE WORK AREA HAS AMPLE LIGHTING** to see the work and that no obstructions will interfere with safe operation **BEFORE** performing any work using the table saw.
  - **ALWAYS TURN OFF SAW** before disconnecting it, to avoid accidental starting when reconnecting to power supply.
- ### ROUTER ACCESSORY SAFETY RULES
- **ALWAYS DISCONNECT SAW FROM POWER SUPPLY BEFORE MAKING ADJUSTMENTS OR ADDING ACCESSORIES.** Make sure the switch is off when reconnecting to power supply.
  - **ALWAYS FEED WORKPIECE AGAINST THE ROTATION OF THE CUTTER.**
  - **DO NOT USE AWKWARD HAND POSITIONS.**
  - **KEEP FINGERS AWAY** from the revolving cutter, and use fixtures when necessary.
  - **ALWAYS USE THE DUST COVER** for overhead guarding.
  - **DO NOT REMOVE JAMMED CUTOFF PIECES** until cutter or blade has stopped and tool has been disconnected from power source.
  - **HOLD THE WORKPIECE FIRMLY AGAINST THE TABLE.**
  - **ALWAYS USE THE SAW'S MASTER SWITCH TO TURN THE ROUTER ON AND OFF.**
  - **THIS TOOL** should have the following markings:
    - a) Wear eye protection.
    - b) Use saw blade guard and riving knife/spreader/splitter for every operation for which it can be used, including all through sawing.
    - c) Keep hands out of the line of saw blade.
    - d) Use a push stick when required.
    - e) Pay particular attention to instructions on reducing risk of kickback.
    - f) Do not perform any operation freehand.
    - g) Never reach around or over the saw blade.
  - **SAVE THESE INSTRUCTIONS.** Refer to them frequently and use to instruct other users. If you loan someone this tool, loan them these instructions also.











**WARNING:** Some dust created by power sanding, sawing, grinding, drilling, and other construction activities contains chemicals known to cause cancer, birth defects or other reproductive harm. Some examples of these chemicals are:

- lead from lead-based paints,
- crystalline silica from bricks and cement and other masonry products, and
- arsenic and chromium from chemically-treated lumber.

Your risk from these exposures varies, depending on how often you do this type of work. To reduce your exposure to these chemicals: work in a well ventilated area, and work with approved safety equipment, such as those dust masks that are specially designed to filter out microscopic particles.



# SYMBOLS

Some of the following symbols may be used on this tool. Please study them and learn their meaning. Proper interpretation of these symbols will allow you to operate the tool better and safer.

SYMBOL	NAME	DESIGNATION/EXPLANATION
V	Volts	Voltage
A	Amperes	Current
Hz	Hertz	Frequency (cycles per second)
W	Watt	Power
min	Minutes	Time
~	Alternating Current	Type of current
—	Direct Current	Type or a characteristic of current
$n_0$	No Load Speed	Rotational speed, at no load
	Class II Construction	Double-insulated construction
.../min	Per Minute	Revolutions, strokes, surface speed, orbits etc., per minute
	Wet Conditions Alert	Do not expose to rain or use in damp locations.
	Read The Operator's Manual	To reduce the risk of injury, user must read and understand operator's manual before using this product.
	Eye Protection	Always wear safety goggles or safety glasses with side shields and a full face shield when operating this product.
	Safety Alert	Precautions that involve your safety.
	No Hands Symbol	Failure to keep your hands away from the blade will result in serious personal injury.
	Pinch Warning	Always watch for movement paying extra attention to potential areas where pinching could occur.
	Hot Surface	To reduce the risk of injury or damage, avoid contact with any hot surface.

# SYMBOLS

The following signal words and meanings are intended to explain the levels of risk associated with this product.

SYMBOL	SIGNAL	MEANING
	<b>DANGER:</b>	Indicates an imminently hazardous situation, which, if not avoided, will result in death or serious injury.
	<b>WARNING:</b>	Indicates a potentially hazardous situation, which, if not avoided, could result in death or serious injury.
	<b>CAUTION:</b>	Indicates a potentially hazardous situation, which, if not avoided, may result in minor or moderate injury.
	<b>CAUTION:</b>	(Without Safety Alert Symbol) Indicates a situation that may result in property damage.

## SERVICE

Servicing requires extreme care and knowledge and should be performed only by a qualified service technician. For service we suggest you return the product to your nearest **AUTHORIZED SERVICE CENTER** for repair. When servicing, use only identical replacement parts.

 **WARNING:** To avoid serious personal injury, do not attempt to use this product until you read thoroughly and understand completely the operator's manual. Save this operator's manual and review frequently for continuing safe operation and instructing others who may use this product.

## WARNING:



The operation of any power tool can result in foreign objects being thrown into your eyes, which can result in severe eye damage. Before beginning power tool operation, always wear safety goggles or safety glasses with side shields and a full face shield when needed. We recommend Wide Vision Safety Mask for use over eyeglasses or standard safety glasses with side shields. Always use eye protection which is marked to comply with ANSI Z87.1.

## SAVE THESE INSTRUCTIONS

# ELECTRICAL

## EXTENSION CORDS

Use only 3-wire extension cords that have 3-prong grounding plugs and 3-pole receptacles that accept the tool's plug. When using a power tool at a considerable distance from the power source, use an extension cord heavy enough to carry the current that the tool will draw. An undersized extension cord will cause a drop in line voltage, resulting in a loss of power and causing the motor to overheat. Use the chart provided below to determine the minimum wire size required in an extension cord. Only round jacketed cords listed by Underwriter's Laboratories (UL) should be used.

\*\*Ampere rating (on tool data plate)

Cord Length	Wire Size (A.W.G.)					
	0-2.0	2.1-3.4	3.5-5.0	5.1-7.0	7.1-12.0	12.1-16.0
25'	16	16	16	16	14	14
50'	16	16	16	14	14	12
100'	16	16	14	12	10	—

\*\*Used on 12 gauge - 20 amp circuit.

NOTE: AWG = American Wire Gauge

When working with the tool outdoors, use an extension cord that is designed for outside use. This is indicated by the letters "WA" on the cord's jacket.

Before using an extension cord, inspect it for loose or exposed wires and cut or worn insulation.

- ⚠ WARNING:** Keep the extension cord clear of the working area. Position the cord so that it will not get caught on lumber, tools or other obstructions while you are working with a power tool. Failure to do so can result in serious personal injury.
- ⚠ WARNING:** Check extension cords before each use. If damaged replace immediately. Never use tool with a damaged cord since touching the damaged area could cause electrical shock resulting in serious injury.
- ⚠ WARNING:** The saw's motor cord must only be plugged into the receptacle provided on the saw which is controlled by the saw's master switch. Never plug the motor cord directly into an extension cord as this will stop the saw's motor from turning OFF.

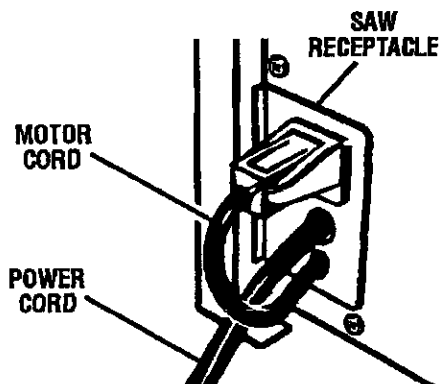

## ELECTRICAL CONNECTION

This tool is powered by a precision built electric motor. It should be connected to a power supply that is **120 volts, 60 Hz, AC only (normal household current)**. Do not operate this tool on direct current (DC). A substantial voltage drop will cause a loss of power and the motor will overheat. If the saw does not operate when plugged into an outlet, double check the power supply.

## SPEED AND WIRING

The no-load speed of this tool is approximately 4,800 rpm. This speed is not constant and decreases under a load or with lower voltage. For voltage, the wiring in a shop is as important as the motor's horsepower rating. A line intended only for lights cannot properly carry a power tool motor. Wire that is heavy enough for a short distance will be too light for a greater distance. A line that can support one power tool may not be able to support two or three tools.

## GROUNDING INSTRUCTIONS

In the event of a malfunction or breakdown, grounding provides a path of least resistance for electric current to reduce the risk of electric shock. This tool is equipped with an electric cord having an equipment-grounding conductor and a grounding plug. The plug must be plugged into a matching outlet that is properly installed and grounded in accordance with all local codes and ordinances.

Do not modify the plug provided. If it will not fit the outlet, have the proper outlet installed by a qualified electrician. Improper connection of the equipment-grounding conductor can result in a risk of electric shock. The conductor with insulation having an outer surface that is green with or without yellow stripes is the equipment-grounding conductor. If repair or replacement of the electric cord or plug is necessary, do not connect the equipment-grounding conductor to a live terminal.

Check with a qualified electrician or service personnel if the grounding instructions are not completely understood, or if in doubt as to whether the tool is properly grounded.

Repair or replace a damaged or worn cord immediately.

This tool is intended for use on a circuit that has an outlet like the one shown in figure 1. It also has a grounding pin like the one shown.

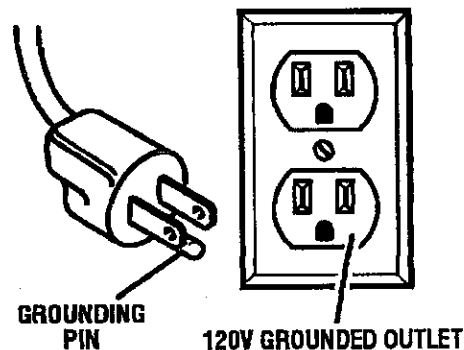

Fig. 1

## GLOSSARY OF TERMS

### **Anti-Kickback Pawls (radial arm and table saws)**

A device which, when properly installed and maintained, is designed to stop the workpiece from being kicked back toward the front of the saw during a ripping operation.

### **Arbor**

The shaft on which a blade or cutting tool is mounted.

### **Bevel Cut**

A cutting operation made with the blade at any angle other than 90° to the table surface.

### **Chamfer**

A cut removing a wedge from a block so the end (or part of the end) is angled rather than at 90°.

### **Compound Cut**

A cross cut made with both a miter and a bevel angle.

### **Cross Cut**

A cutting or shaping operation made across the grain or the width of the workpiece.

### **Cutter Head (planers and jointers)**

A rotating piece of adjustable blades. The cutter head removes material from the workpiece.

### **Dado Cut**

A non-through cut which produces a square-sided notch or trough in the workpiece (requires a special blade).

### **Featherboard**

A device used to help control the workpiece by guiding it securely against the table or fence during any ripping operation.

### **FPM or SPM**

Feet per minute (or strokes per minute), used in reference to blade movement.

### **Freehand**

Performing a cut without the workpiece being guided by a fence, miter gauge, or other aids.

### **Gum**

A sticky, sap-based residue from wood products.

### **Heel**

Alignment of the blade to the fence.

### **Kerf**

The material removed by the blade in a through cut or the slot produced by the blade in a non-through or partial cut.

### **Kickback**

A hazard that can occur when the blade binds or stalls, throwing the workpiece back toward operator.

### **Leading End**

The end of the workpiece pushed into the tool first.

### **Miter Cut**

A cutting operation made with the workpiece at any angle to the blade other than 90°.

### **Non-Through Cuts**

Any cutting operation where the blade does not extend completely through the thickness of the workpiece.

### **Push Blocks and Push Sticks**

Devices used to feed the workpiece through the saw blade during cutting operations. A push stick (not a push block) should be used for narrow ripping operations. These aids help keep the operator's hands well away from the blade.

### **Pilot Hole (drill presses)**

A small hole drilled in a workpiece that serves as a guide for drilling large holes accurately.

### **Resaw**

A cutting operation to reduce the thickness of the workpiece to make thinner pieces.

### **Resin**

A sticky, sap-based substance that has hardened.

### **Revolutions Per Minute (RPM)**

The number of turns completed by a spinning object in one minute.

### **Ripping or Rip Cut**

A cutting operation along the length of the workpiece.

### **Riving Knife/Spreader/Splitter (table saws)**

A metal piece, slightly thinner than the blade, which helps keep the kerf open and also helps to prevent kickback.

### **Saw Blade Path**

The area over, under, behind, or in front of the blade. As it applies to the workpiece, that area which will be or has been cut by the blade.

### **Set**

The distance that the tip of the saw blade tooth is bent (or set) outward from the face of the blade.

### **Snipe (planers)**

Depression made at either end of a workpiece by cutter blades when the workpiece is not properly supported.

### **Throw-Back**

The throwing back of a workpiece usually caused by the workpiece being dropped into the blade or being placed inadvertently in contact with the blade.

### **Through Sawing**

Any cutting operation where the blade extends completely through the thickness of the workpiece.

### **Workpiece or Material**

The item on which the operation is being done.

### **Worktable**

Surface where the workpiece rests while performing a cutting, drilling, planing, or sanding operation.

# FEATURES

## PRODUCT SPECIFICATIONS

Blade Arbor .....	5/8 in.	Rating .....	120 V, 60 Hz - AC only
Blade Diameter .....	10 in.	Input .....	15 Amperes
Blade Tilt .....	0° - 45°	No Load Speed .....	4,800/min.
Net Weight Without Leg Stand .....	85 lbs.	Cutting Depth at 0° .....	3-9/16 in.
Net Weight With Leg Stand .....	110 lbs.	Cutting Depth at 45° .....	2-1/2 in.

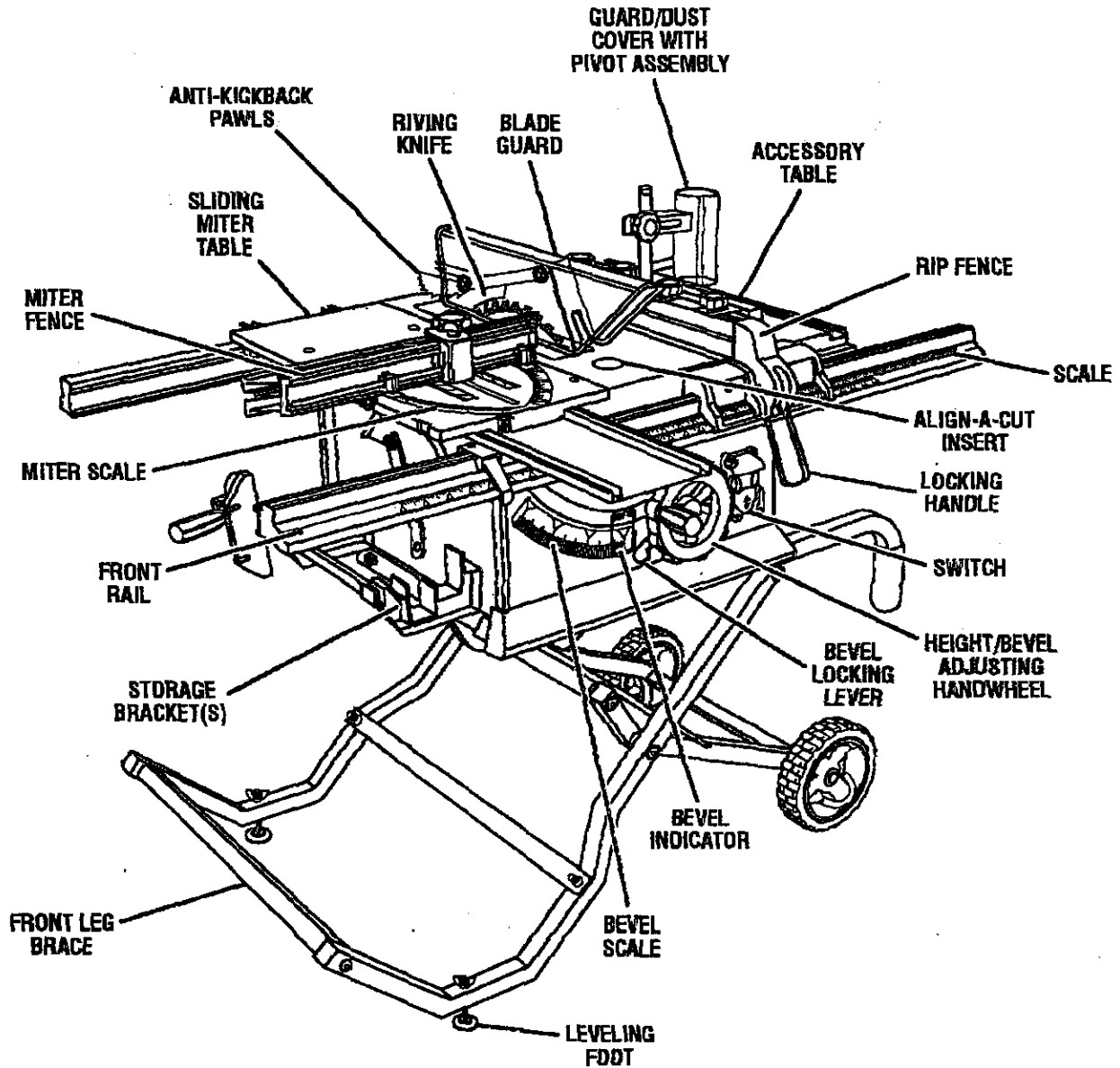

Fig. 2



## FEATURES

### KNOW YOUR TABLE SAW

See Figure 2.

Before attempting to use this product, familiarize yourself with all operating features and safety rules.

**ACCESSORY TABLE** - The accessory table may be used on either the right or left side of the saw as needed and has been designed for use with some routers. A router mounted on the accessory table will provide expanded capabilities for making rabbets, grooves, chamfers, dove-tails, and mortise and tenon joints.

**ADJUSTING CLAMP** - This clamp locks the miter fence at the desired cutting angle.

**ALIGN-A-CUT INSERT** - A plastic insert on which marks may be made to indicate the location of the saw cut on the workpiece.

**ANTI-KICKBACK PAWLS** - Kickback is a hazard in which the workpiece is thrown back toward the operator. The teeth on the anti-kickback pawls point away from the workpiece. If the workpiece should be pulled back toward the operator, the teeth dig into the wood to help prevent or reduce the possibility of kickback.

**BEVEL SCALE** - The easy-to-read scale on the front of the cabinet shows the exact blade angle.

**BLADE** - This saw is provided with a 36-tooth, 10 in. carbide blade. The blade is raised and lowered with the height adjusting handwheel. Bevel angles are locked with the bevel locking lever.

 **WARNING:** Do not use blades rated less than the speed of this tool. Failure to heed this warning could result in personal injury.

**BLADE GUARD** - Always keep the blade guard down over the saw blade for through-sawing cuts.

**BEVEL LOCKING LEVER** - This lever, placed just under the saw table surface on the front of the cabinet, locks the angle setting of the blade.

**HEIGHT/BEVEL ADJUSTING HANDWHEEL** - Located on the front of the cabinet, use this handwheel to lower and raise the blade for height adjustments or blade replacement. This handwheel also makes the adjustment for bevel angles easy.

**LEG STAND** - Attached to the table saw base, the leg stand opens and closes with ease.

**MITER FENCE** - The fence attaches to the sliding miter table and can be angled for miter and compound miter cuts as well as straight cuts such as cross, bevel cross, rip, and bevel rip cuts.

**MITER GAUGE** - The miter gauge aligns the wood for a cross cut. The easy-to-read indicator shows the exact angle for a miter cut, with positive stops at 90° and 45°.

**MITER GAUGE GROOVES** - The miter gauge rides in the grooves on the accessory table.

**MOTOR** - The powerful induction motor, with capacitor start and V-belt drive, is housed in a sturdy steel base.

**RAILS** - Front and rear rails provide support for large workpieces and the rip fence.

**RIP FENCE** - A sturdy metal fence guides the workpiece and is secured with the locking handle. Grooves run along the top and sides of the rip fence for use with optional clamps and accessories.

**RIVING KNIFE/SPREADER** - A metal piece of the blade guard assembly, slightly thinner than the saw blade, which helps keep the kerf open and prevent kickback.

**SCALE** - Located on the front rail, the easy-to-read scale provides precise measurements for rip cuts.

**SLIDING MITER TABLE** - The miter table slides easily along the miter table base allowing the operator to move the workpiece across the saw table.

**SWITCH ASSEMBLY** - This saw has an easy access power switch located below the front rail. To lock the switch in the OFF position, remove the switch key from the switch. Place the key in a location that is inaccessible to children and others not qualified to use the tool.

# FEATURES

## OPERATING COMPONENTS

The upper portion of the blade projects up through the table and is surrounded by an insert called the throat plate. The height of the blade is set with a handwheel on the front of the cabinet. To accommodate wide panels, the saw table has rails on each side. Detailed instructions are provided in the *Operation* section of this manual for the basic cuts: cross cuts, miter cuts, bevel cuts, and compound cuts.

The sliding miter table assembly is used for cross cutting operations. The miter fence is easily adjusted to cut wood at an angle by loosening the adjusting clamp, setting the fence to the miter scale, and retightening the clamp. The sliding miter table, which rests on a base mounted on the rails, can be repositioned along the rails for wide work. It can be reversed so the projecting base is in the back and can be moved from the left side to the right side as needed. With the miter fence removed, the miter table offers additional support for other operations such as ripping.

The rip fence is used to position work for lengthwise cuts. A scale on the front rail shows the distance between the rip fence and the blade.

It is very important to use the blade guard assembly for all through-sawing operations. The blade guard assembly includes: riving knife/spreader/splitter, anti-kickback pawls, and plastic blade guard.

The saw features a receptacle on the right side of the cabinet that permits use of accessories. Use only accessories that are listed for use with this tool. When using a listed accessory, unplug the saw motor cord and use the receptacle and the saw's power switch to operate the accessory.

## POWER SWITCH

This saw is equipped with a power switch that has a built-in locking feature. This feature is intended to prevent unauthorized and possible hazardous use by children and others.

### TO TURN YOUR SAW ON:

- With the switch key inserted into the switch, lift the switch button to turn **ON ( I )**.

### TO TURN YOUR SAW OFF:

- Press the switch button down to turn **OFF ( O )**.

### TO LOCK YOUR SAW:

- Press the switch button down.
- Remove the switch key from the switch and store in a safe, secure location.

**⚠ WARNING:** Always remove the switch key when the tool is not in use and keep it in a safe place. In the event of a power failure, turn the switch **OFF ( O )** and remove the key. This action will prevent the tool from accidentally starting when power returns.

**⚠ WARNING:** ALWAYS make sure your workpiece is not in contact with the blade before operating the switch to start the tool. Failure to heed this warning may cause the workpiece to be kicked back toward the operator and result in serious personal injury.

**⚠ WARNING:** To reduce the risk of accidental starting, Always make sure the switch is in the **OFF ( O )** position before plugging tool into the power source.

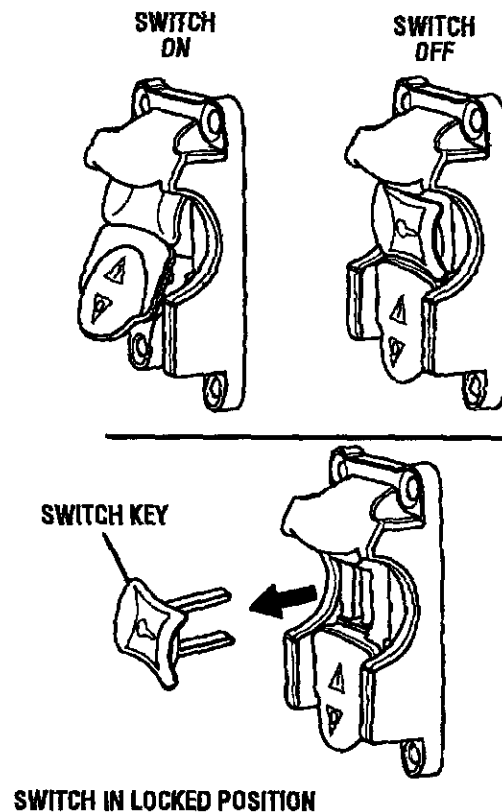

Fig. 3

## FEATURES

### BLADES

For maximum performance, it is recommended that you use the Craftsman 36-tooth, 10 in. carbide combination blade provided with your saw. Additional blade styles of the same high quality are available for specific operations such as ripping. Your local dealer can provide you with complete information.

**⚠ WARNING:** Do not use blades rated less than the speed of this tool. Failure to heed this warning could result in personal injury.

## TOOLS NEEDED

The following tools (not included) are needed for making adjustments:

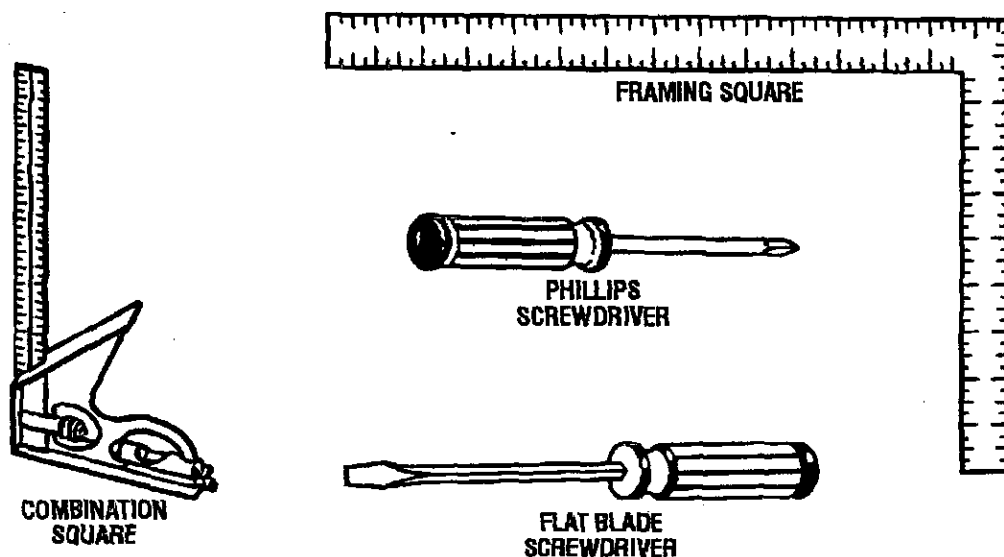

Fig. 4

# LOOSE PARTS

The following items are included with your table saw:

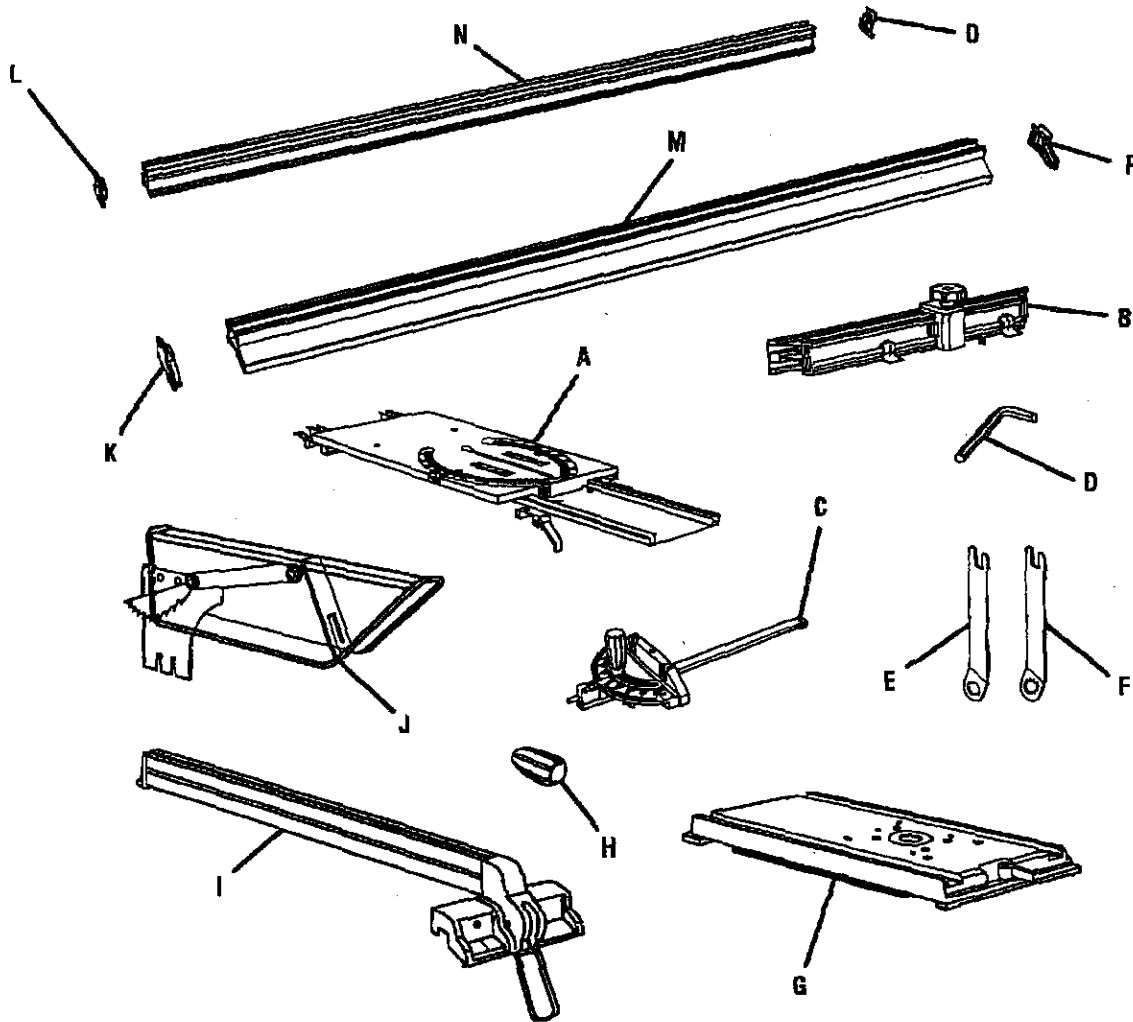

Fig. 5

A. Sliding Miter Table.....	1
B. Miter Fence with Adjusting Clamp .....	1
C. Miter Gauge.....	1
D. Hex Key (1/8 in., 3/16 in., 2/32 in., 5/32 in.).....	4
E. Large Blade Wrench .....	1
F. Small Blade Wrench.....	1
G. Accessory Table .....	1
H. Bevel Handle Assembly .....	1
I. Rip Fence.....	1
J. Blade Guard with Riving Knife and Anti-Kickback Pawls .....	1
K. End Cap (Front Rail, Left).....	1
L. End Cap (Rear Rail, Left).....	1
M. Front Rail.....	1
N. Rear Rail.....	1
O. End Cap (Front Rail, Right).....	1
P. End Cap (Rear Rail, Right).....	1



# LOOSE PARTS LIST

The following items are included with your table saw:

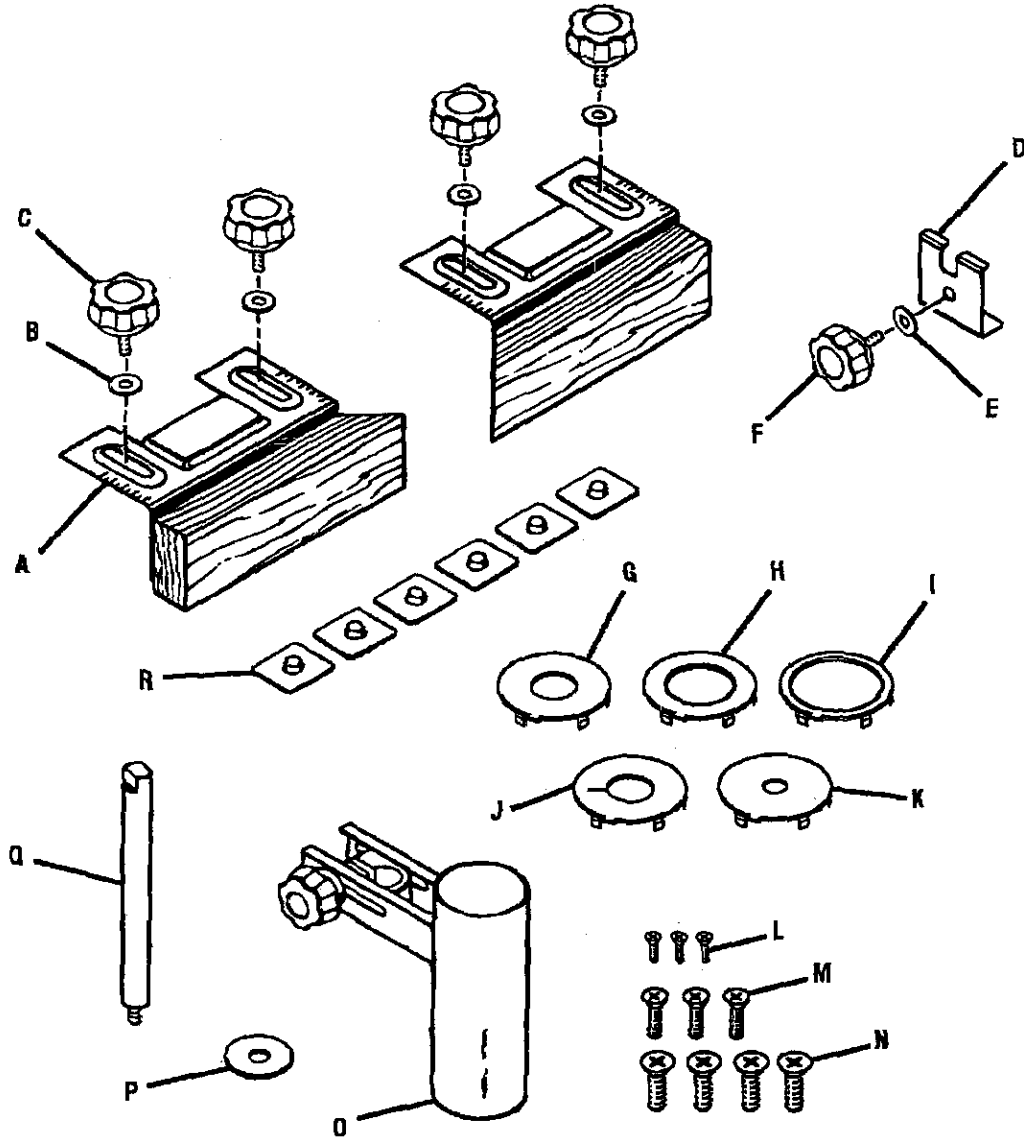

Fig. 6

<p>A. Guide Fence with Guide Block ..... 2</p> <p>B. Flat Washer (1/4 in. x 16) ..... 4</p> <p>C. Knob Bolt (1/2 in.) ..... 4</p> <p>D. Table Clamping Bracket ..... 1</p> <p>E. Washer (5/16 in.) ..... 1</p> <p>F. Knob Bolt (3/4 in.) ..... 1</p> <p>G. Throat Plate (1 in.) ..... 1</p> <p>H. Throat Plate (1-1/2 in.) ..... 1</p> <p>I. Throat Plate (2 in.) ..... 1</p>	<p>J. Throat Plate (1-1/8 in.) ..... 1</p> <p>K. Throat Plate (1/2 in.) ..... 1</p> <p>L. Screw, #10 In.-32 x 3/4 In ..... 3</p> <p>M. Screw, 5/16-18 in. x 3/4 in ..... 3</p> <p>N. Screw, M8 x 24 ..... 4</p> <p>O. Guard/Dust Cover with Pivot Assembly ..... 1</p> <p>P. Spacer ..... 1</p> <p>Q. Post ..... 1</p> <p>R. T-Nut, 5/16 in. (Special) ..... 6</p>
---	--

# ASSEMBLY

## UNPACKING

This product requires assembly.

- Carefully lift the saw from the carton and place it on a level work surface.
  - NOTE:** This tool is heavy. To avoid back injury, keep your knees bent and lift with your legs, not your back, and do not lift saw without help.
- Inspect the tool carefully to make sure no breakage or damage occurred during shipping.
- Do not discard the packing material until you have carefully inspected and satisfactorily operated the tool.
- The saw is factory set for accurate cutting. After assembling it, check for accuracy. If shipping has influenced the settings, refer to specific procedures explained in this manual.
- If any parts are damaged or missing, please call 1-800-932-3188 for assistance.

**WARNING:** If any parts are missing, do not operate this tool until the missing parts are replaced. Failure to do so could result in possible serious personal injury.

**WARNING:** Do not attempt to modify this tool or create accessories not recommended for use with this tool. Any such alteration or modification is misuse and could result in a hazardous condition leading to possible serious personal injury.

**WARNING:** Do not connect to power supply until assembly is complete. Failure to comply could result in accidental starting and possible serious personal injury.

**WARNING:** Do not lift the saw without help. Hold it close to your body. Keep your knees bent and lift with your legs, not your back. Ignoring these precautions can result in back injury.

**WARNING:** Never stand directly in line with the blade or allow hands to come closer than 3 in. to the blade. Do not reach over or across the blade. Failure to heed this warning can result in serious personal injury.

**WARNING:** To avoid serious personal injury, always make sure the table saw is securely mounted to this leg stand. NEVER remove the saw from the leg stand.

## TO OPEN THE LEG STAND

See Figures 7 - 8.

- Grasp the grips on the saw table and stand it upright as shown in figure 7 below.

- Step on the release lever and pull the grips toward you at the same time.
- Once the leg stand is released from the release lever, ease the leg stand toward the floor by pushing the grips toward the floor.
- With your hands on the grips, push the leg stand towards the ground until the table saw is in an upright position.
  - NOTE:** The release lever will close over the center brace locking the leg stand in an upright position.

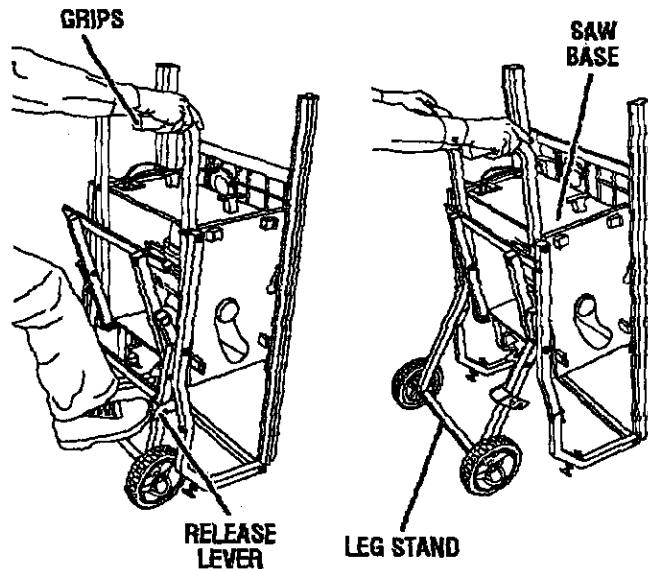

Fig. 7

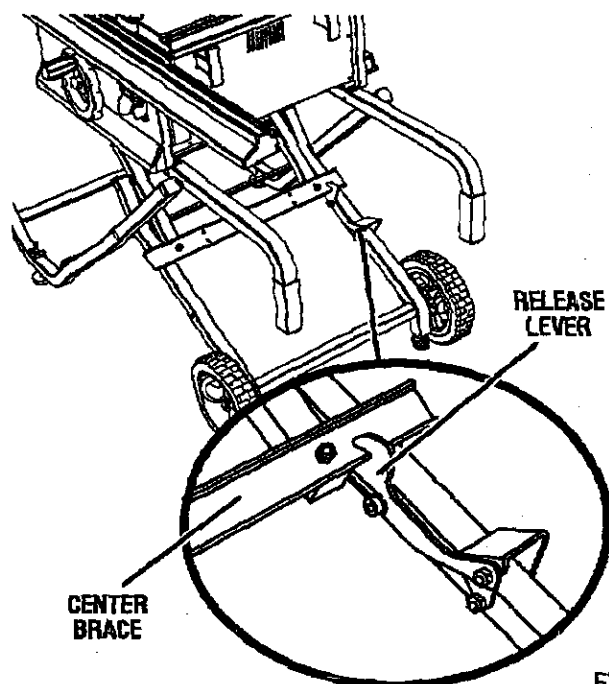

Fig. 8

# ASSEMBLY

## TO SECURE/LEVEL THE SAW

See Figure 9.

With the leg stand open and the table saw resting on a flat, level surface, the saw should not move or rock from side to side.

If the saw rests on the wheels and rolls, loosen each wheel stop by turning counterclockwise. The leg stand should rest on each stop only slightly. If the wheel stop is turned too much, the stop will interfere with the opening and closing motion of the leg stand.

If the saw rocks from side to side, the leveling feet need adjusting until the leg stand is balanced.

- Loosen both the top and bottom wing nuts.
- Lift the saw slightly so that you may turn the leveling foot until the leg stand no longer rocks.
  - Turning clockwise will lower the foot
  - Turning counterclockwise will raise the foot

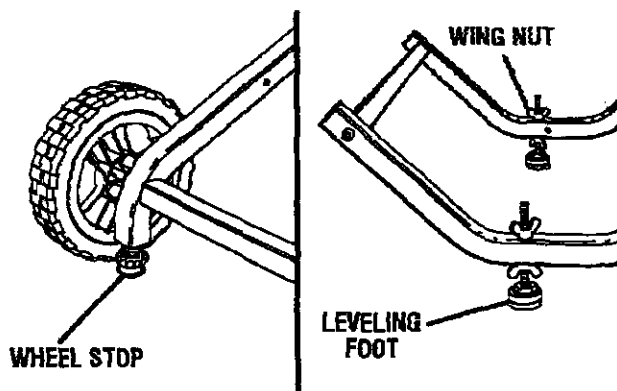

Fig. 9

## TO STORE THE TABLE SAW ACCESSORIES

See Figures 10. - 11

The table saw has two convenient storage areas specifically designed for the saw's accessories. These accessories must be securely stored prior to closing the leg stand and moving the saw.

The rip fence, miter fence, and miter gauge should be stored in the brackets located on the side of the saw cabinet. Simply snap each accessory in place to hold it securely.

Storage hooks for the sliding miter table are located on the back of the saw cabinet. This storage area is to be used only for moving the saw or when the saw is not being used.

**NOTE:** During operation of the saw, the sliding miter table must be mounted on the rails. **NEVER** operate the saw with the sliding miter table in the storage position because it blocks the dust exhaust port.

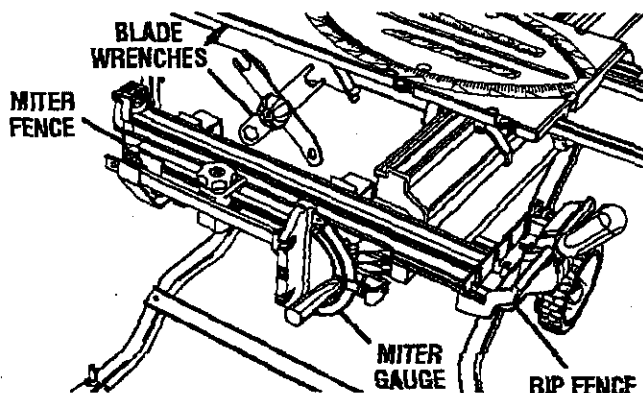

Fig. 10

Stand facing the back of the table saw. The longest part of the miter table base must be stored to the left. To secure the sliding miter table:

- Rest the sliding miter table on the bottom right-hand storage hook and the miter base on the lower miter bottom left-hand hook.
- Align the bottom miter locking clamp with the bottom left storage hook. Push the sliding miter table back toward the cabinet until it is resting against all four hooks.
- Lock the miter locking clamps on the left by pushing clamps toward the side of the cabinet securing the miter table in place.

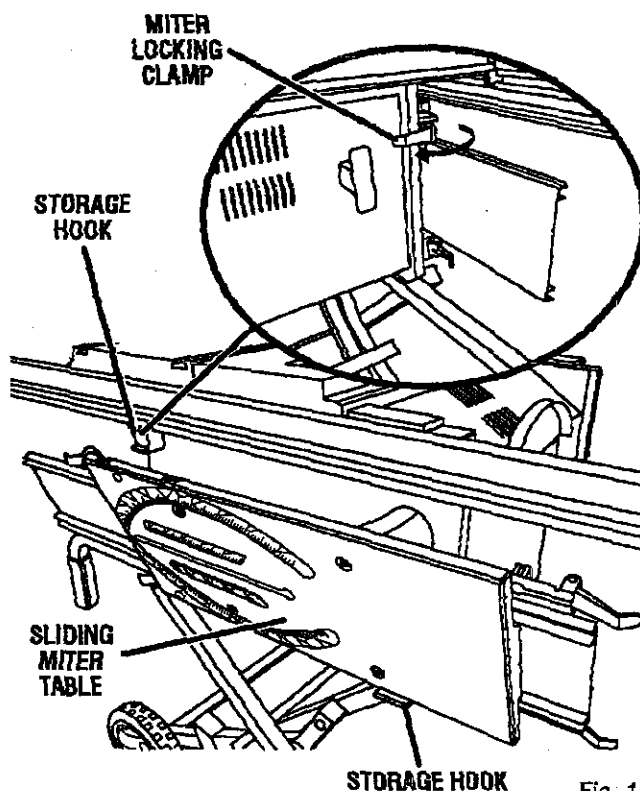

Fig. 11

## ASSEMBLY

### TO INSTALL BEVEL HANDLE ASSEMBLY

See Figure 12.

- Lift the end cap off the bevel handle assembly using a flat blade screwdriver.
- Hold the nylon nut securely and turn the screw counter-clockwise to remove the nut completely.  
**NOTE:** Do not remove the screw from the handle or the washer from the end of the screw.
- Place the nylon nut into the recessed hole on the back of the height adjusting handwheel and hold in place.
- Slide the handle, screw, and washer into the hole on the height adjusting handwheel.
- Using a flathead screwdriver, turn the screw clockwise and tighten in place.
- Push the end cap back in place on the end of the handle.

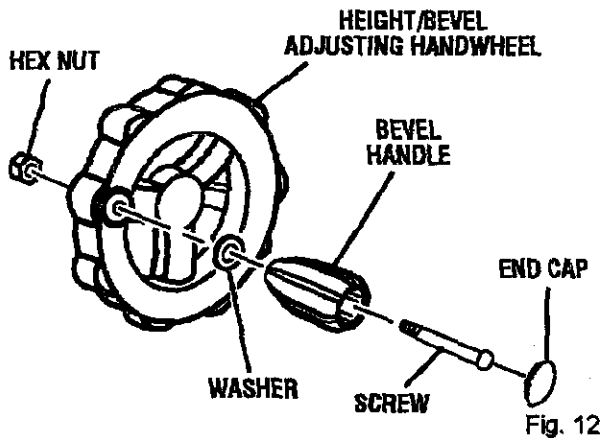

### TO INSTALL FRONT AND BACK RAILS

See Figures 13 - 14.

- Loosen the front rail clamps one half turn from the tightened position. Loosen the square rail holder nut one-fourth (1/4) turn to allow the front rail to slide over it.
- Mount the front rail with the scale facing the outside toward the operator.
- Check to make sure the rail clamps will securely clamp the rail before sliding the entire assembly into position. If not, tighten the square rail holder nut one-fourth (1/4) turn and recheck.
- Slide the rail into position over both clamps and secure.
- Mount the rear rail, following the same clamping procedure as shown for the front rail.

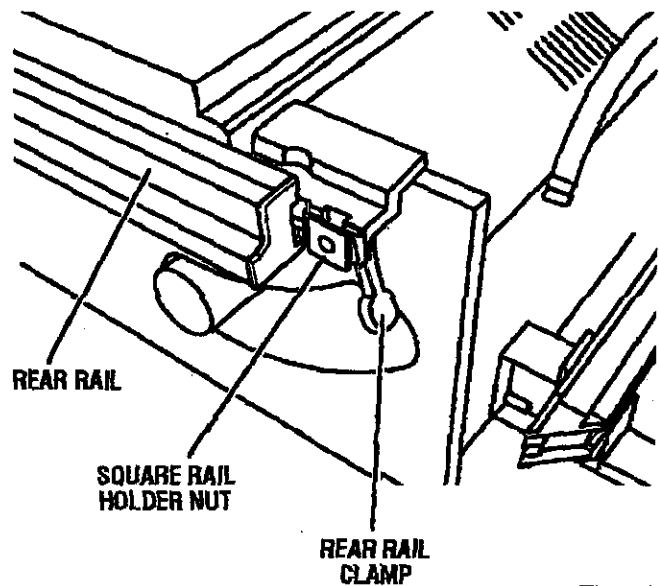
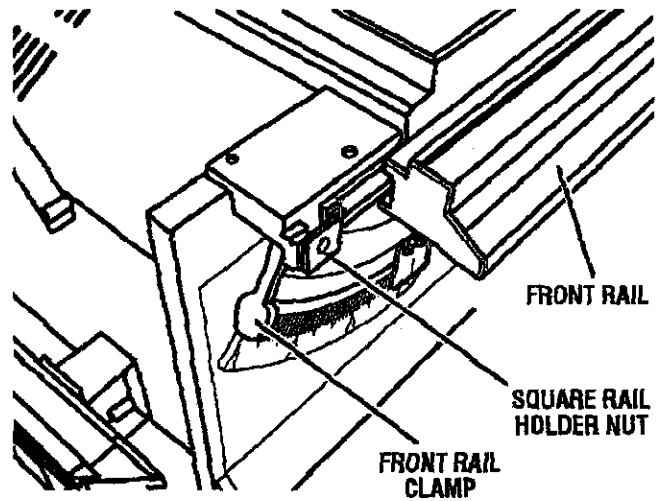

# ASSEMBLY

## TO UNLOCK/MOVE THE RAILS

See Figure 15.

The front and back rails will need to be positioned so they do not touch the floor when the leg stand is closed. Using the bottom scale as a guide, the scale will need to be aligned to the saw blade at the 14 in. mark. To unlock and move the rails:

- Loosen the front rail clamps by pushing the lever to the left.
- Slide the rail to the desired position.
- Secure the rail in position by pushing the clamp to the right.
- Repeat above steps with the rear rail placing it in the same location as the front rail.

**NOTE:** When the rails are moved to the right, use caution to avoid tripping on the front leg brace.

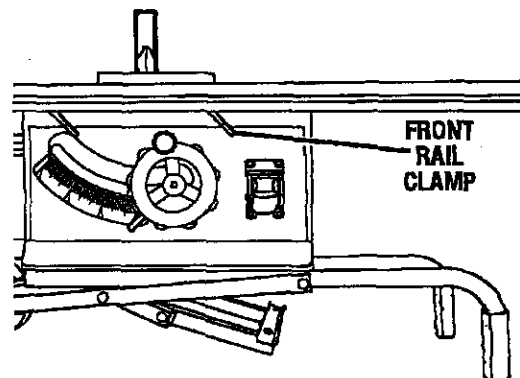

Fig. 15

## TO CLOSE THE LEG STAND AND MOVE THE SAW

See Figure 16.

Store the sliding miter table on the back of the saw cabinet. See **To Store the Table Saw Accessories** on the previous page. Next, set the front and back rails to 14 in. as described above.

**NOTE:** Never close the leg stand or attempt to move the table saw until both the above steps are completed.

### To close the leg stand:

- At the same time, step on the release lever, grasp the grips, and lift the handles up and away from the body.
- Push the table saw until the release lever clicks and locks into place.

### To move the leg stand:

- Holding the grips firmly, pull the handles toward you until the leg stand and saw are balanced on the wheels.
- Push the saw to the desired location then either open the leg stand for immediate saw operation or store the saw in a dry environment.

**NOTE:** Never move the table saw unless the sliding miter table is securely stored.

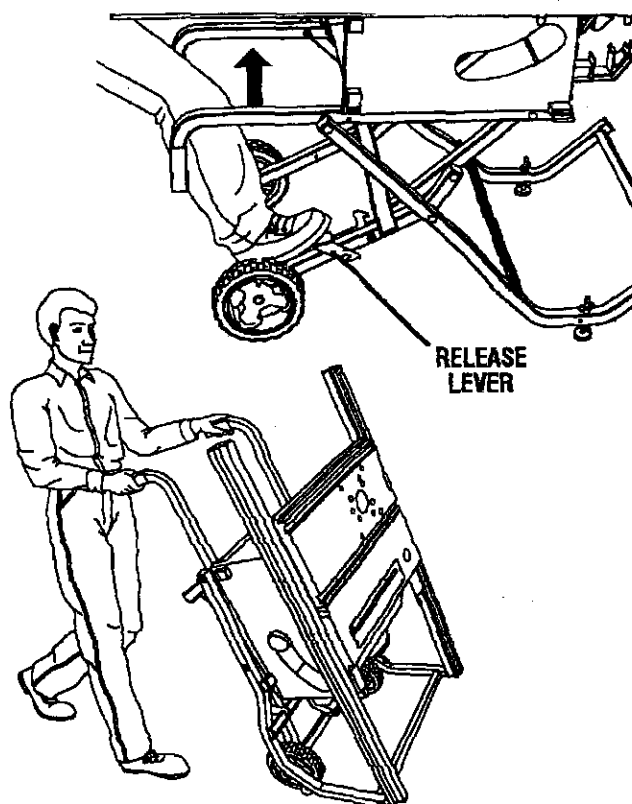

Fig. 16

## TO REMOVE / REPLACE THE THROAT PLATE

See Figure 17.

- Raise the blade 2 in. above the saw table.
- Loosen the screws in the throat plate.
- Lift the throat plate from the saw.
- To reinstall the throat plate, align the holes in the throat plate with the holes in the saw table.
- Retighten the screws, being careful not to overtighten, which can cause the throat plate to bow or bend.

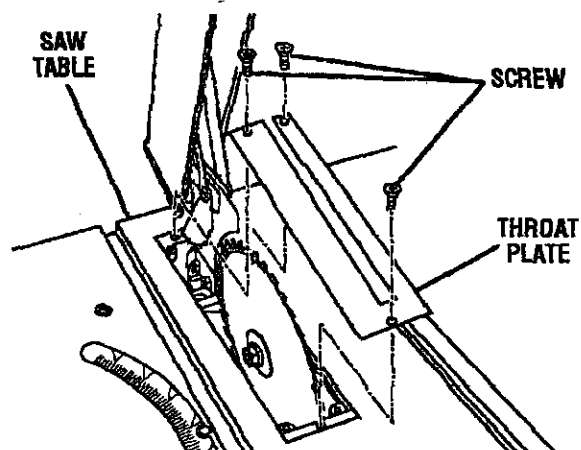

Fig. 17

# ASSEMBLY

## TO CHECK SAW BLADE INSTALLATION

See Figure 18.

**CAUTION:** To work properly, the saw blade teeth must point down toward the front of the saw. Failure to do so could cause damage to the saw blade, the saw, or the workpiece.

- Lower the saw blade and remove the throat plate.
- Make sure the bevel locking lever is securely pushed to the left. Raise the saw blade to its full height by turning the height/bevel adjusting handwheel clockwise.

### To loosen the blade:

- Using the small blade wrench, place the flat open end on the flats on the arbor shaft.
- Insert the closed end of the large blade wrench over the hex nut. Holding both wrenches firmly, pull the larger wrench forward to the front of the machine.

### To tighten the blade:

- Using the small blade wrench, place the flat open end into the flats on the arbor shaft.
- Insert the closed end of the large blade wrench over the hex nut. Holding both wrenches firmly, push the larger wrench to the back of the machine. Make sure the blade nut is securely tightened. Do not overtighten.

**NOTE:** Arbor shaft has left hand threads.

Check all clearances for free blade rotation. See **To Set the Scale to the Blade** in the *Adjustment* Section. In cutting operations, the scale will be set to the side of the blade where the cut will be measured and made.

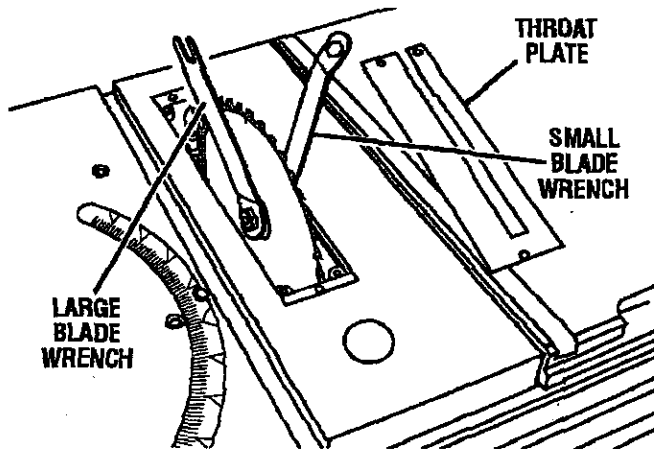

Fig. 18

## TO INSTALL THE SLIDING MITER TABLE AND MITER FENCE

See Figures 19 - 20.

- Remove the sliding miter table from the storage area by pulling the miter locking clamps away from the saw cabinet.
- Install the sliding miter table assembly over the front and rear rails. Check that it slides easily on the rails. Push both front miter locking clamps down evenly on each side to secure. Repeat for both rear miter locking clamps.

**NOTE:** Do not force miter locking clamps down. Tighten only to flat "seated" position.

- Remove the miter fence from the miter fence storage on the side of the saw cabinet.
- To install the miter fence to the sliding miter table, loosen the adjusting clamp knob so the bolt has enough clearance to slide in the table slot.

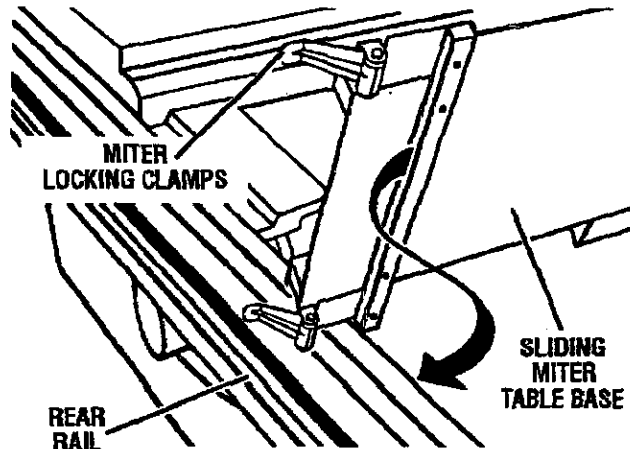

Fig. 19

- Mount the miter fence to the miter table by installing the locator pin (below the miter fence) into holes "A", "B", "C", or "D". (Holes "A" and "D" are closest to the blade). At the same time, place the attachment bolt in the slot.

**NOTE:** Holes "A" and "D" should be used for short pieces of wood and holes "B" and "C" should be used for long pieces of wood.

- Properly adjust the miter indicator to the scale on the end of the fence opposite the locator pin.
- Retighten the adjusting clamp knob.



# ASSEMBLY

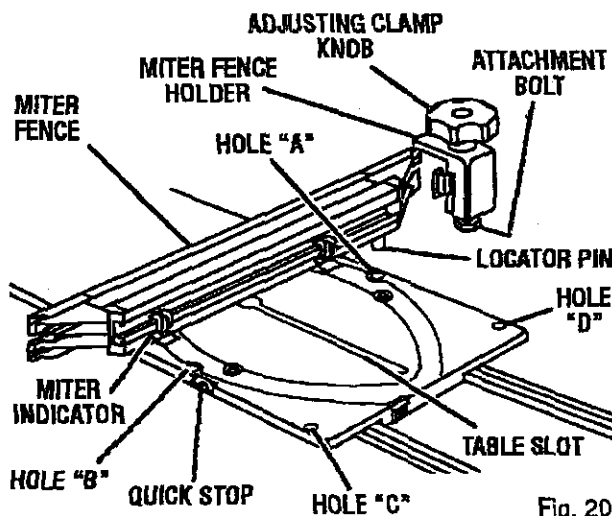

Fig. 20

## TO LOCK SLIDING MITER TABLE

See Figure 21.

The miter table slides allowing the operator to slide the workpiece across the saw. A miter slide lock is mounted on the front of the miter table to lock it in place. The miter slide lock is placed in a slot on the base to align the miter table with the front edge of the saw table. The sliding miter table should be locked for any cut in which the operator prefers a fixed table.

- To lock the miter table with the base projecting to the front, place miter slide lock in the back slot on the base.
- To lock the miter table with the base projecting to the back, place miter slide lock in the front slot on the base.

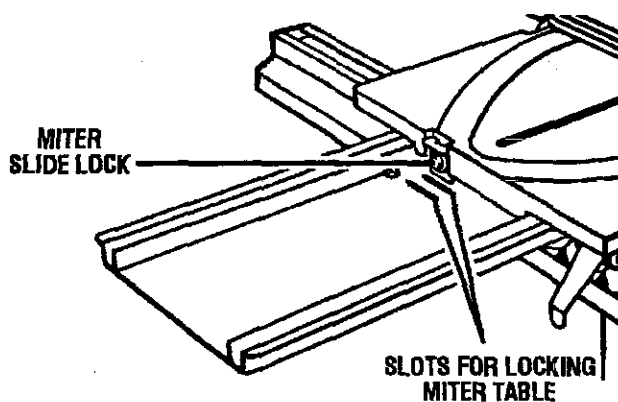

Fig. 21

## TO CHECK SLIDING MITER TABLE ASSEMBLY

The square relationship between the blade and the miter fence as it travels the entire distance from the front to the rear of the miter table base during a cut is very important for making precise and accurate cuts. The sliding miter table assembly has been preset at the factory. However, misalignment during shipping or requirements for very precise and accurate cuts may require realignment.

To avoid unnecessary setups and adjustments, we suggest that you check these setups carefully with a framing square and make practice cuts in scrap wood before making finish cuts in good workpieces.

**NOTE:** Follow the general rule of measuring twice and cutting once.

Do not loosen any screws. Once screws have been loosened, settings must be reset.

Two basic checks should be made before using the miter table: (1) the miter base must be parallel to the blade as the table slides from the front to back, and (2) the miter fence must be square to the blade when set at exactly zero (0°) on the miter table scale.

**NOTE:** The miter table has adjustment screws for squaring miter fence to blade and maintaining 0° scale settings when miter base adjustments are required. These checks and adjustments are explained in step-by-step procedures in the *Operation* section and depend on each other.

## TO INSTALL ACCESSORY TABLE

See Figure 22.

- Fit the tabs on the back of the accessory table into the rear rail.
- Position the slot on the underside of the accessory table onto the front rail and tighten the lever securely.

**NOTE:** To use the optional router accessories included with this product, refer to the *Operation* section for usage.

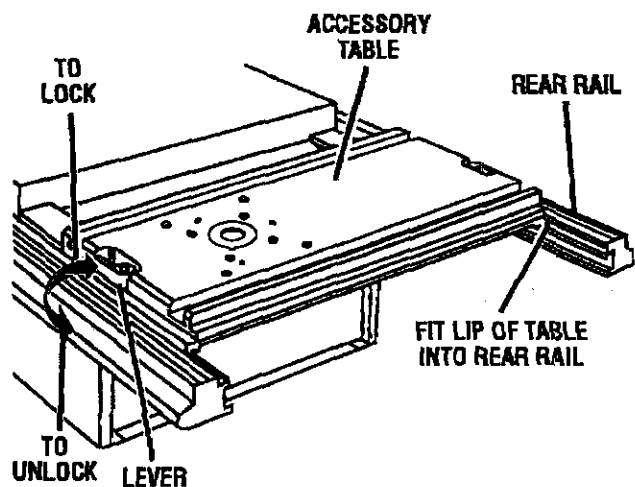

Fig. 22

## ASSEMBLY

### TO INSTALL BLADE GUARD ASSEMBLY

See Figure 23.

Proper installation of the blade guard assembly means that the saw blade and riving knife are in alignment. **ALWAYS** align the riving knife to the saw blade prior to turning on the table saw.

- Lower the blade and remove the throat plate.
- Make sure the bevel locking lever is securely pushed to the left. Raise the saw blade to its full height by turning the height/bevel adjusting handwheel clockwise.
- Loosen the two hex nuts enough to slide the riving knife down between the shims. **Do not remove the hex nuts.** Partially retighten the hex nuts. Check the blade and riving knife alignment, and make sure the riving knife clears the blade by 1/8 in.
- Align the blade and riving knife as shown. Blade alignment with the riving knife can be adjusted for different blade widths. Refer to **To Check, Replace, or Adjust the Riving Knife and Blade Guard Assembly** in the *Adjustment* Section. Check the blade guard assembly for clearances and free movement.

**NOTE:** If the riving knife is not positioned correctly (with blade up) it could contact the saw table when the blade is lowered and restrict blade elevation.

- Tighten hex nuts securely.
- Lower the blade and reinstall the throat plate. Tighten the screws securely.

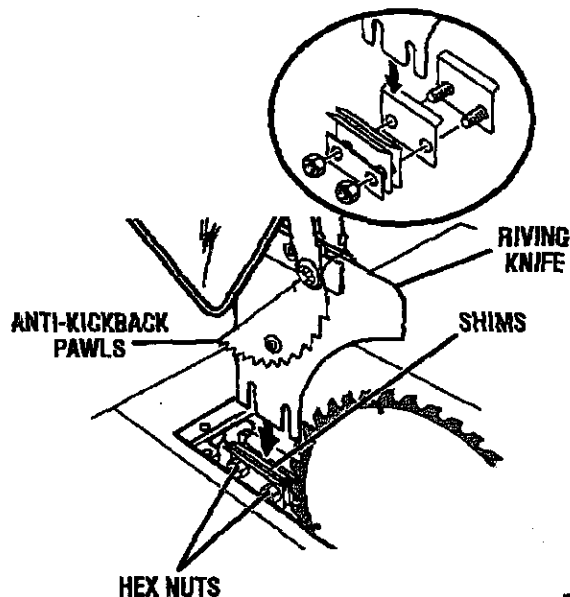

Fig. 23

## OPERATION

- ▲ **WARNING:** Do not allow familiarity with tools to make you careless. Remember that a careless fraction of a second is sufficient to inflict severe injury.
- ▲ **WARNING:** Always wear safety goggles or safety glasses with side shields when operating tools. Failure to do so could result in objects being thrown into your eyes in possible serious injury.
- ▲ **WARNING:** Do not use any attachments or accessories not recommended by the manufacturer of this tool. The use of attachments or accessories not recommended can result in serious personal injury.
- ▲ **WARNING:** Although many of the illustrations in this manual are shown with the blade guard removed for clarity, do not operate the saw without the blade guard unless specifically instructed to do so.

### APPLICATIONS

You may use this tool for the purposes listed below:

- Straight line cutting operations such as cross cutting, ripping, mitering, beveling, and compound cutting
- Dado or molding cuts with optional accessories
- Cabinet making and woodworking

**NOTE:** This table saw is designed to cut wood and wood composition products only.

### BASIC OPERATION OF THE TABLE SAW

The 3-prong plug must be plugged into a matching outlet that is properly installed and grounded according to all local codes and ordinances. Improper connection of the equipment can result in electric shock. Do not modify the plug if it will not fit the outlet. Have the correct outlet installed by a qualified electrician. Refer to the *Electrical* section in this manual.

# OPERATION

## CAUSES OF KICKBACK

Kickback can occur when the blade stalls or binds, kicking the workpiece back toward you with great force and speed. If your hands are near the saw blade, they may be jerked loose from the workpiece and may contact the blade. Kickback can cause serious injury. Use precautions to avoid the risks.

Kickback can be caused by any action that pinches the blade in the wood such as:

- Making a cut with incorrect blade depth
- Sawing into knots or nails in the workpiece
- Twisting the wood while making a cut
- Failing to support work
- Forcing a cut
- Cutting warped or wet lumber
- Using the wrong blade for the type of cut
- Not following correct operating procedures
- Misusing the saw
- Failing to use the anti-kickback pawls
- Cutting with a dull, gummed-up, or improperly set blade

## AVOIDING KICKBACK

- Always use the correct blade depth setting. The top of the blade teeth should clear the workpiece by 1/8 in. to 1/4 in.
- Inspect the work for knots or nails before beginning a cut. Knock out any loose knots with a hammer. Never saw into a loose knot or nail.
- Always use the rip fence when rip cutting and the miter gauge when cross cutting. This helps prevent twisting the wood in the cut.
- Always use clean, sharp, and properly-set blades. Never make cuts with dull blades.
- To avoid pinching the blade, support the work properly before beginning a cut.
- When making a cut, use steady, even pressure. Never force cuts.
- Do not cut wet or warped lumber.
- Always hold your workpiece firmly with both hands or with push sticks. Keep your body in a balanced position to be ready to resist kickback should it occur. Never stand directly in line with the blade.
- Use the right type of blade for the cut being made.

## CUTTING AIDS

See Figure 24.

Push sticks are devices used for safely pushing a workpiece through the blade. They can be made from scrap wood in various sizes and shapes to be used in a specific project. The stick must be narrower than the workpiece, with a 90° notch in one end and shaping for a grip on the other end.

A push block has a handle fastened by recessed screws from the underside. Use it on non-through cuts.

**CAUTION:** Be sure the screws in a push block are recessed to avoid damaging the saw or workpiece.

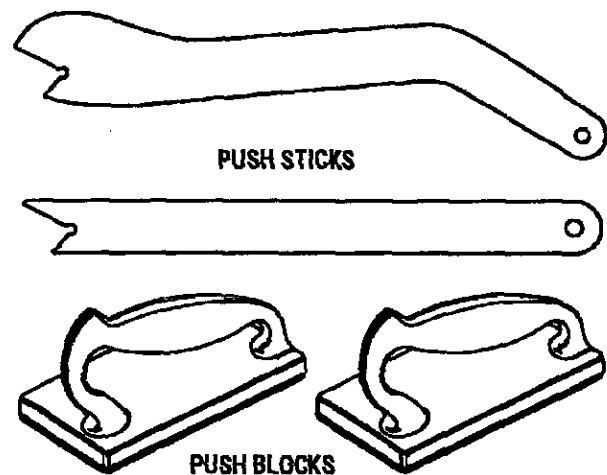

Fig. 24

# OPERATION

## TYPES OF CUTS

See Figure 25.

There are six basic cuts: 1) the cross cut, 2) the rip cut, 3) the miter cut, 4) the bevel cross cut, 5) the bevel rip cut, and 6) the compound (bevel) miter cut. All other cuts are combinations of these basic six. Operating procedures for making each kind of cut are given later in this section.

**WARNING:** Always make sure the blade guard and anti-kickback pawls are in place and working properly when making these cuts to avoid possible injury.

Cross cuts are straight 90° cuts made across the grain of the workpiece. The wood is fed into the cut at a 90° angle to the blade, and the blade is vertical.

Rip cuts are made with the grain of the wood. To avoid kickback while making a rip cut, make sure one side of the wood rides firmly against the rip fence.

Miter cuts are made with the wood at any angle to the blade other than 90°. The blade is vertical. Miter cuts tend to "creep" away from the miter fence during cutting. This can be controlled by holding the workpiece securely against the miter fence.

**WARNING:** Always use a push stick when cutting small pieces of wood, and also to finish the cut when ripping a long narrow piece of wood, to prevent your hands from getting close to the blade.

Bevel cuts are made with an angled blade. Bevel cross cuts are across the wood grain, and bevel rip cuts are with the grain. The rip fence must always be on the left side of the blade for bevel rip cuts.

Compound (or bevel) miter cuts are made with an angled blade on wood that is angled to the blade. Be thoroughly familiar with making cross cuts, rip cuts, bevel cuts, and miter cuts before trying a compound miter cut.

## CUTTING TIPS

Dado and rabbet cuts are non-through cuts which can be either rip cuts or cross cuts. Carefully read and understand all sections of this operator's manual before attempting any operation.

**WARNING:** Do not use blades rated less than the speed of this tool. Failure to heed this warning could result in personal injury.

- The kerf (the cut made by the blade in the wood) will be wider than the blade to avoid overheating or binding. Make allowance for the kerf when measuring wood.
- Make sure the kerf is made on the waste side of the measuring line.

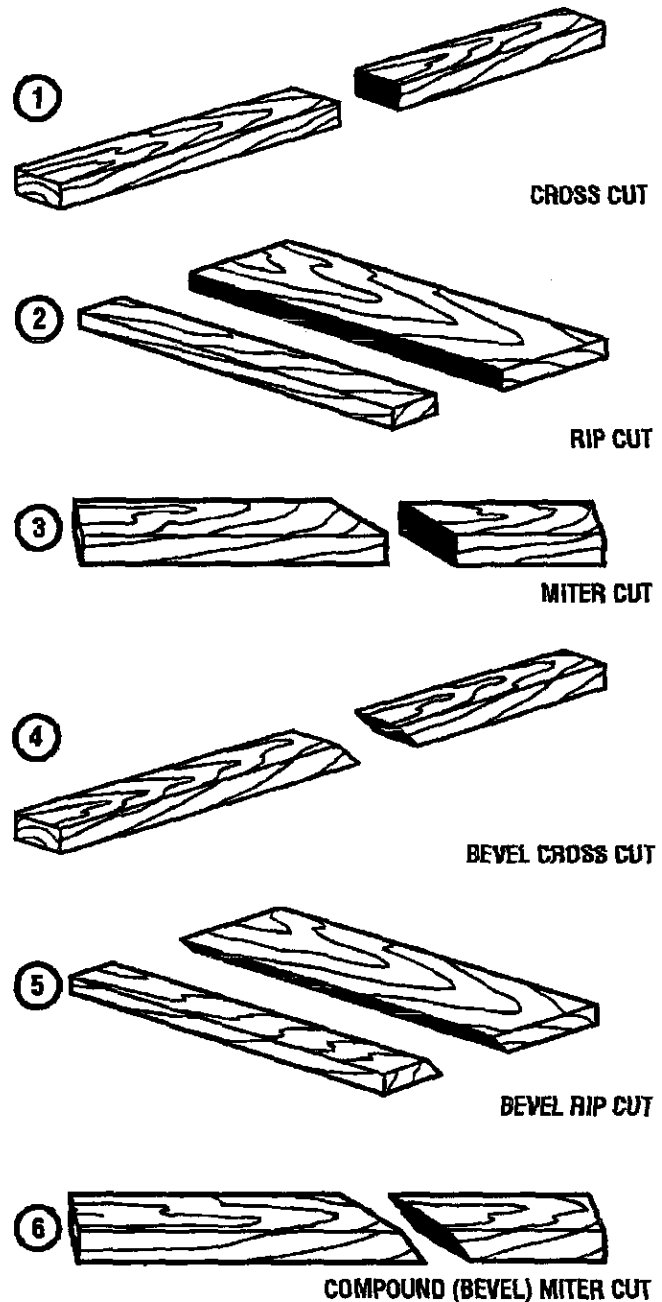

Fig. 25

- Cut the wood with the finish side up.
- Knock out any loose knots with a hammer before making the cut.
- Always provide proper support for the wood as it comes out of the saw.

# OPERATION

## FEATHERBOARD

A featherboard is a device used to help control the workpiece by guiding it securely against the table or fence. Featherboards are especially useful when ripping small workpieces and for completing non-through cuts. The end is angled with a number of short kerfs to give a friction hold on the workpiece and locked in place on the table with a C-clamp. Test that it can resist kickback.

**WARNING:** Place the featherboard against the uncut portion of the workpiece to avoid kickback that could cause serious personal injury.

## HOW TO MAKE A FEATHERBOARD

See Figure 26.

The featherboard is an excellent project for the saw. Select a solid piece of lumber approximately  $\frac{3}{4}$  in. thick,  $3\text{-}\frac{5}{8}$  in. wide and 18 in. long. Mark the center of the width on one end of the stock. Miter one-half of the width to  $30^\circ$  and miter the other half of the same end to  $45^\circ$  (see page 32 for information on miter cuts). Mark the board from the point at 6 in., 8 in., 10 in., and 12 in. Drill a  $\frac{3}{8}$  in. hole at the 8 in., 10 in., and 12 in. marks. Prepare the saw for ripping as discussed on page 31. Set the rip fence to allow approximately a  $\frac{1}{4}$  in. "finger" to be cut in the stock. Feed the stock only to the mark previously made at 6 in. Turn the saw OFF and allow the blade to completely stop rotating before removing the stock. Reset the rip fence and cut spaced rips into the workpiece to allow approximately  $\frac{1}{4}$  in. fingers and  $\frac{1}{8}$  in. spaces between the fingers.

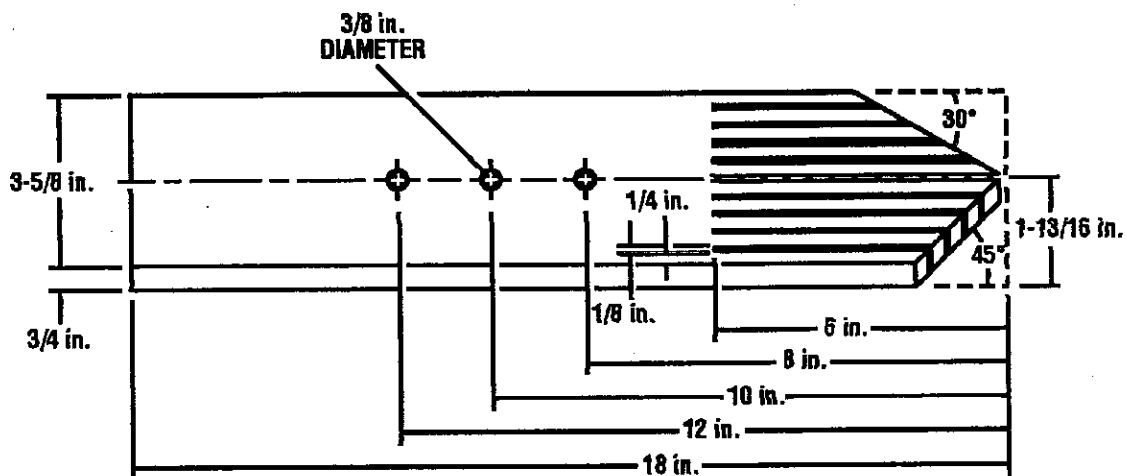

Fig. 26

## HOW TO MOUNT A FEATHERBOARD

See Figure 27.

Remove the adjusting clamp knob, bolt, and washer from the miter fence holder. Place the bolt through one of the holes in the featherboard. Positioning the featherboard will depend on the placement of the bolt and the position of the sliding miter table on the rails. Place the washer on the bolt and attach the adjusting clamp knob, loosely. Position the featherboard with the hex head of the bolt in the miter table slot but do not tighten. Completely lower the saw blade. Position the rip fence to the desired adjustment for the cut to be performed and lock. Place the workpiece against the fence and over the saw blade area. Adjust the featherboard to apply resistance to the workpiece just forward of the blade. Securely tighten the adjusting clamp knob to secure the featherboard in place. Attach a C-clamp to further secure the featherboard to the edge of the sliding miter table.

**WARNING:** Do not locate the featherboard to the rear of the blade. If positioned improperly, kickback can result from the featherboard pinching the workpiece and binding the blade in the saw kerf. Failure to heed this warning can result in serious personal injury.

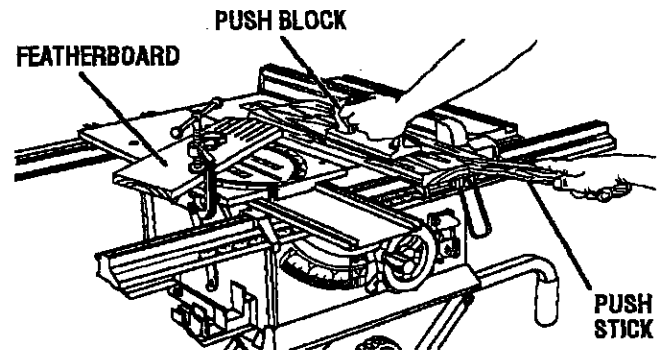

Fig. 27

# OPERATION

## TO CHANGE THE BLADE DEPTH

See Figure 28.

The blade depth should be set so that the outer points of the blade are higher than the workpiece by approximately 1/8 in. to 1/4 in. but the lowest points (gullets) are below the top surface.

- Push the bevel locking lever to the left for elevation mode.
- Raise the blade by turning the height/bevel adjusting hand-wheel clockwise or lower it by turning the handle counterclockwise.

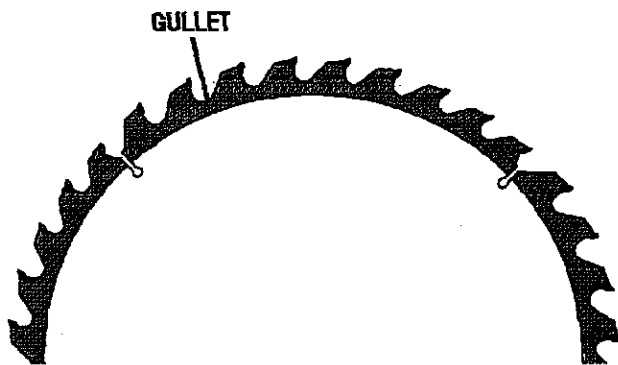

Fig. 28

## TO CHANGE THE BLADE ANGLE

See Figure 29.

- Push the bevel locking lever to the right for angle mode.
- Angle the blade by turning the height/bevel adjusting handwheel until the bevel indicator shows the correct angle.
- Return the bevel locking lever securely to the left to lock the angle, while holding the height/bevel adjusting handwheel in place.

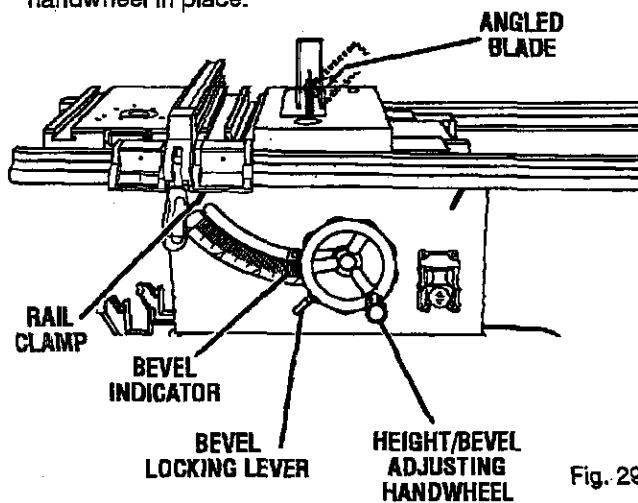

Fig. 29

## CHECKING SLIDING MITER TABLE AND MAKING ADJUSTMENTS

### TO CHECK MITER BASE PARALLELISM

See Figures 30 - 31.

- Unplug the saw.
- Set saw up as if you were preparing to make a cut. Tighten rail clamps, miter locking clamps, adjusting clamp, etc.
- Slide miter table (A) to the front of miter base (B) as far as it will go. Place a reference mark (C) near the end of the miter table as shown in figure 30.

**NOTE:** Front of miter base is on infeed side of saw.

- Place a reference mark on one of the blade teeth (D) and rotate the blade (E) so that the reference mark on the blade is at the front of the throat plate.
- Place a framing square (G) against the blade and align with reference mark on miter table. Measure the distance between the blade and the edge of miter table.

**NOTE:** Place framing square between carbide teeth and measure from blade. This step will insure framing square is square against blade from the front to back of blade.

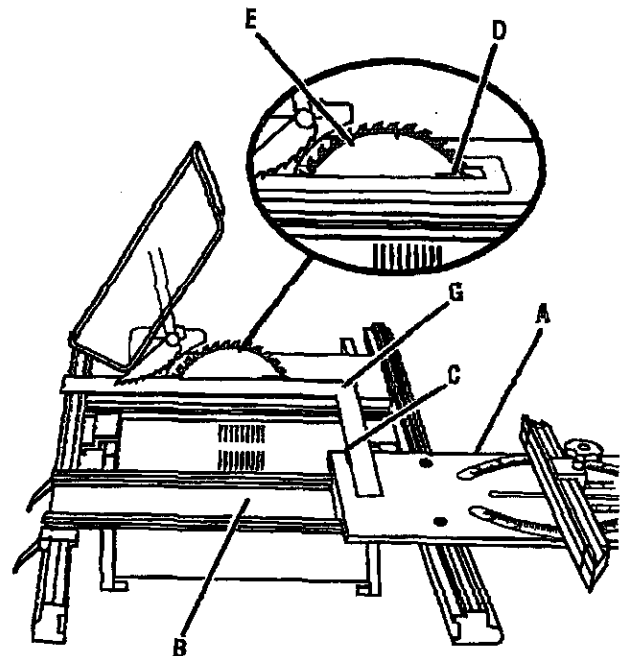

Fig. 30

# OPERATION

- Remove framing square and slide miter table to the rear of miter base as far as it will go.
- Rotate the blade so the reference mark on the blade is at the rear of the throat plate. Measuring from the same mark on the blade at the rear will eliminate the effect of blade wobble.
- Place framing square against the blade and align with the same reference mark on the miter table. Measure the distance between the blade and the edge of the miter table at the rear.
- Compare whether the front and rear measurements are the same. If they are the same, proceed with checking the miter fence alignment. If not, this indicates the miter base needs aligning. Miter base must then be adjusted before checking miter fence alignment. See **To Adjust The Miter Base** section that follows.

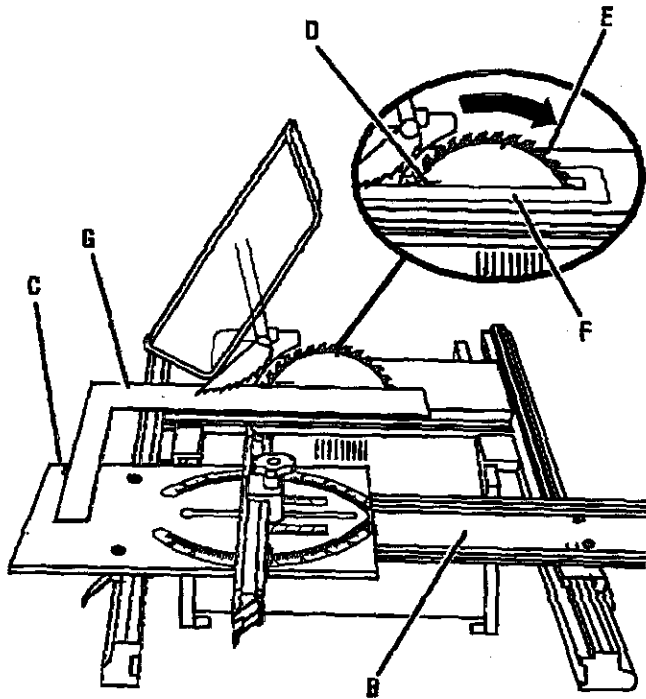

Fig. 31

## TO CHECK MITER FENCE ALIGNMENT

See Figure 32.

The miter fence must be perpendicular to the blade when set at zero degrees.

- Set the miter fence (H) at 0°. Miter indicator (I) should be set precisely on 0° and secured in place with adjusting clamp (J).

**NOTE:** The quick-stop is not necessary for this checking procedure. However, you may want to check and adjust it to 0° at this time. See the **To Adjust Quick-Stop** section that follows.

- Place a framing square (G) firmly against the miter fence (H), with the other side against the blade (E).
- Check whether the miter fence and blade are square with each other. With the framing square against the miter fence there should be no gap from the front to the rear of the blade.
- If a gap exists, the miter fence may be out of square.
- Rotate the blade and recheck. If there is a consistent gap between the front and rear of the blade, the miter table needs aligning. Follow the adjustment procedures that follow.

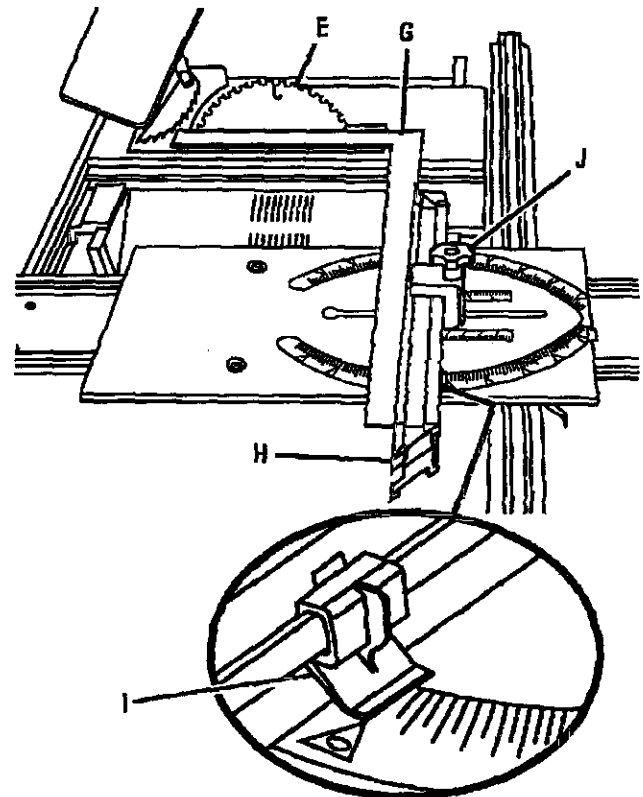

Fig. 32

# OPERATION

## TO ADJUST THE MITER BASE

See Figure 33.

**Remember:** Check all settings before loosening screws for the following procedures. Once screws have been loosened, these settings must be reset.

Eight screws are visible on the miter base (B).

- Four screws (K) are on the holder plates and secure these plates to the rails. It is not necessary to loosen or adjust these screws for this adjustment procedure.
- Another pair of screws (L) is in the base, at the rear. Loosen these two screws (L) and the rear miter locking clamps (M).
- The last pair of screws is located on the infeed side of the base. Loosen the left screw (N) only.
- The right screw (O) will be used as a pivot point.  
**NOTE:** The front two miter locking clamps (P) and rail clamps should remain locked.
- Adjust the miter base so that it is parallel to the blade see **To Check Miter Base Parallelism**.
- Retighten the left front screw (N).
- Clamp the rear miter locking clamps (M).
- Retighten the two rear screws (L).

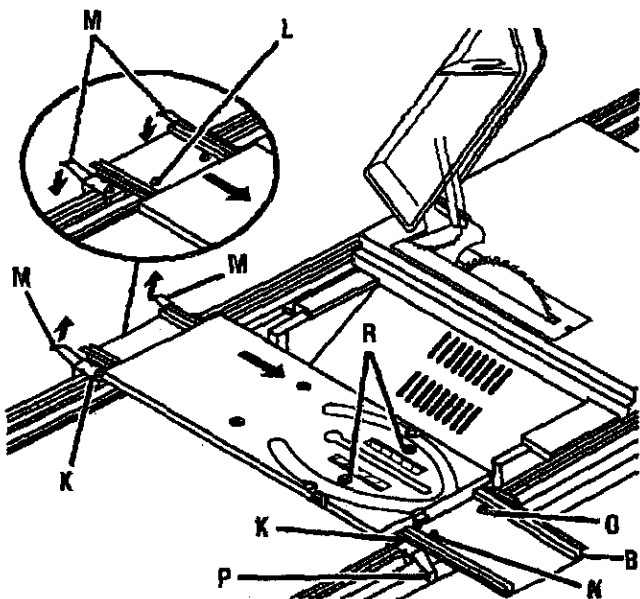

Fig. 33

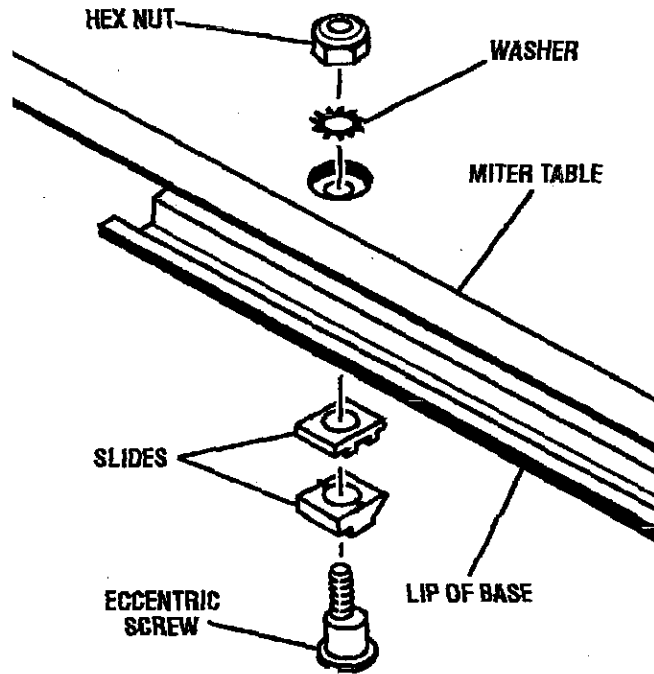

Fig. 34

## TO ADJUST THE MITER FENCE

See Figures 34 - 35.

- Set the miter fence (H) at 0°. Miter indicator should be set precisely on 0° and secured in place with adjusting clamp (J).
- There are four slides located under the sliding miter table. These slides let the miter table move on the base. Three slides are mounted on eccentric screws that can be adjusted by loosening the hex nuts on top of the miter table.
- Loosen the rear hex nuts (Q) on top of sliding miter table for this adjustment procedure.  
**NOTE:** The front screws (R) are only needed to remove excessive play in the slides due to wear from extended use. They are not needed for this procedure. The right front hex nut is a non-eccentric pivot and should never be loosened.
- Adjust the right rear eccentric screw from the lower side of the miter table so that maximum play exists between the slide and miter base.
- Push left rear of miter table snugly against miter base as shown by the arrow (S) in figure 35 and secure.
- Place a framing square firmly against the miter fence, with the other side against the blade.
- Adjust left rear screw from underneath miter table until miter fence and blade are square with each other.

# OPERATION

- Tighten hex nut securely.
- Adjust right rear screw from underneath miter table to remove excessive play.
- Tighten hex nut securely.
- Recheck your setups carefully. Also make sure all screws, hex nuts, etc., have been tightened securely.
- If sliding miter table assembly is still not square with the blade, repeat the above procedures as needed.
- Make sure that slides remain square to miter base edge to prevent "cocking" which will result in excessive play in miter table.

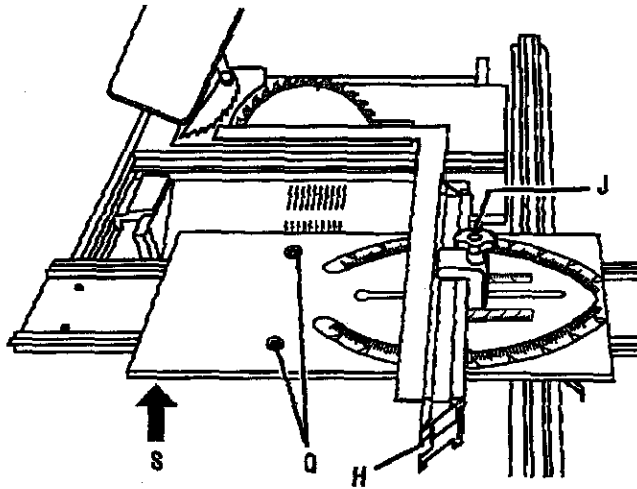

Fig. 35

## TO ADJUST QUICK STOP

See Figure 36.

The quick stop is preset at the factory to stop the miter fence at exactly zero degrees. However, when sliding miter table adjustments are made, these adjustments may cause the quick stop to need adjusting. Check quick stop with miter scale set at zero degrees. If adjustments are needed, proceed with the following steps:

- Loosen the eccentric screw holding the quick stop.
- Place the quick stop against the miter fence with miter scale set at zero degrees.
- Adjust eccentric screw until it holds quick stop securely against miter fence.
- Retighten hex nut, securing eccentric screw and quick stop.
- Check your work. If the quick stop is not at zero degrees, repeat above steps.

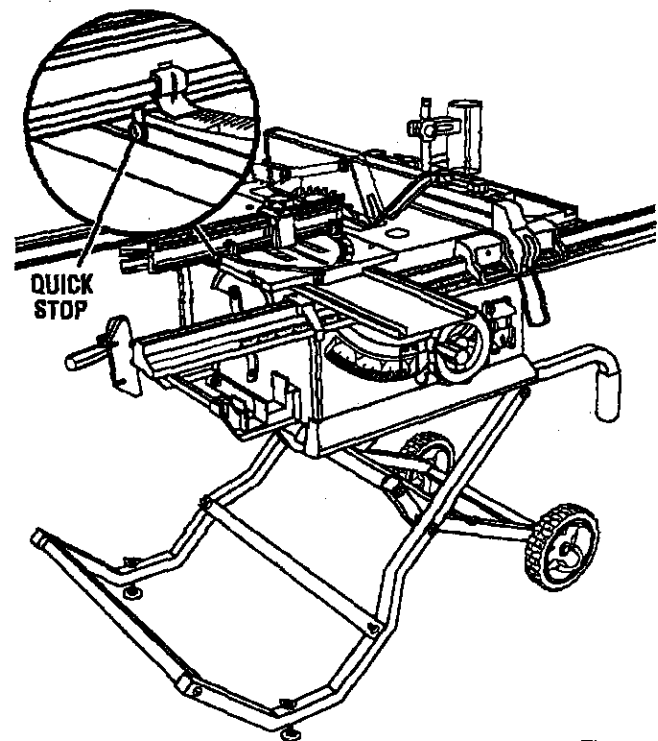

Fig. 36

## OPERATION

**WARNING:** To reduce the risk of injury, always make sure the rip fence is parallel to the blade before beginning any operation.

### TO SET THE RIP FENCE SCALE INDICATOR TO THE BLADE

See Figure 37.

Use the following steps to set the rip fence scale indicator to the blade. Begin with the blade at a zero angle (straight up).

- Unplug the saw.
- Loosen the rip fence by depressing the lock and lifting the locking handle.
- Using a framing square, set the rip fence 2 in. from the blade tip edge.
- Loosen the screw on the scale indicator.
- Tighten the screw and check the dimension and the rip fence.

### TO USE THE RIP FENCE

See Figure 38.

- Place the rear lip on the rear of the saw table and pull slightly toward the front of the unit.
- Lower the front end of the rip fence onto the guide surfaces on top of the front rail.
- Push the rip fence lever down to automatically align and secure the fence.

Check for a smooth gliding action. If adjustments are needed, see **To Check the Alignment of the Rip Fence to the Blade** in the *Adjustment* section of this manual.

### TO USE THE MITER GAUGE

See Figure 39.

The miter gauge provides greater accuracy in angled cuts. For very close tolerances, test cuts are recommended.

There are two miter gauge channels, one on either side of the blade. When making a 90° cross cut, you can use either miter gauge channel. When making a beveled cross cut (the blade tilted in relation to the table) the miter gauge should be located in the slot on the right so that the blade is tilted away from the miter gauge and your hands.

The miter gauge can be turned 60° to the right or left.

- Loosen the lock knob.
- With the miter gauge in the miter gauge slot, rotate the gauge until the desired angle is reached on the scale.
- Retighten the lock knob.

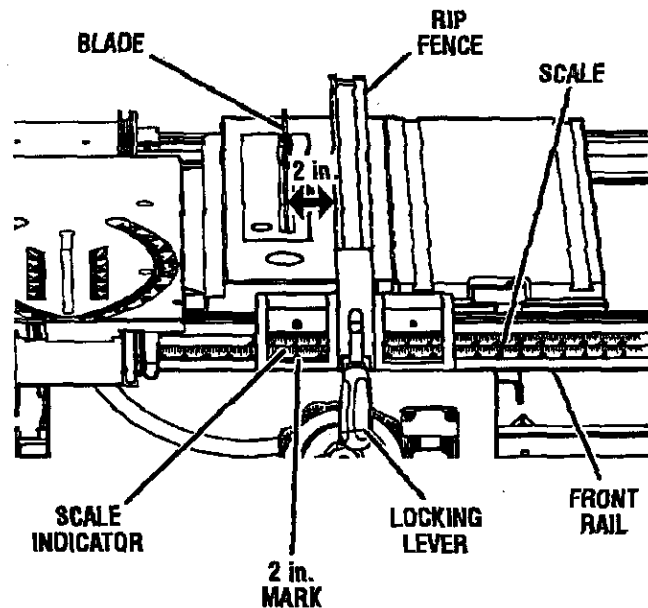

Fig. 37

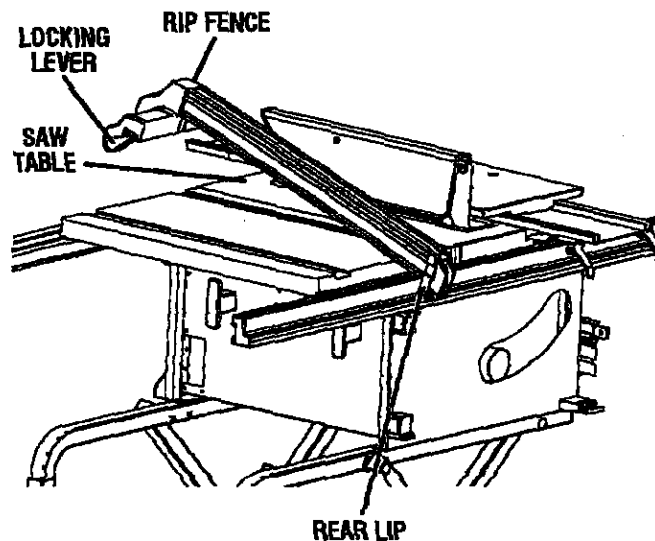

Fig. 38

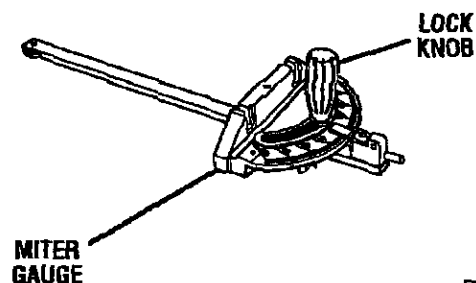

Fig. 39

# OPERATION

## MAKING CUTS

The blade provided with the saw is a high-quality combination blade suitable for ripping and cross cut operations.

**WARNING:** Do not use blades rated less than the speed of this tool. Failure to heed this warning could result in personal injury.

Use the miter gauge when making cross, miter, bevel, and compound miter cuts. To secure the angle, lock the miter gauge in place by twisting the lock knob clockwise. Always tighten the lock knob securely in place before use.

**NOTE:** It is recommended that you place the piece to be saved on the left side of the blade and that you make a test cut on scrap wood first.

## MAKING A CROSS CUT

See Figures 40 - 41.

**WARNING:** Using the rip fence as a cutoff gauge when crosscutting will result in kickback which can cause serious personal injury.

**WARNING:** Make sure the blade guard assembly is installed and working properly to avoid serious possible injury.

It is recommended you make test cuts on scrap wood.

- Remove the rip fence by lifting the locking handle.
- Set the blade to the correct depth for the workpiece.
- Set the miter fence to 0° and tighten the lock knob.

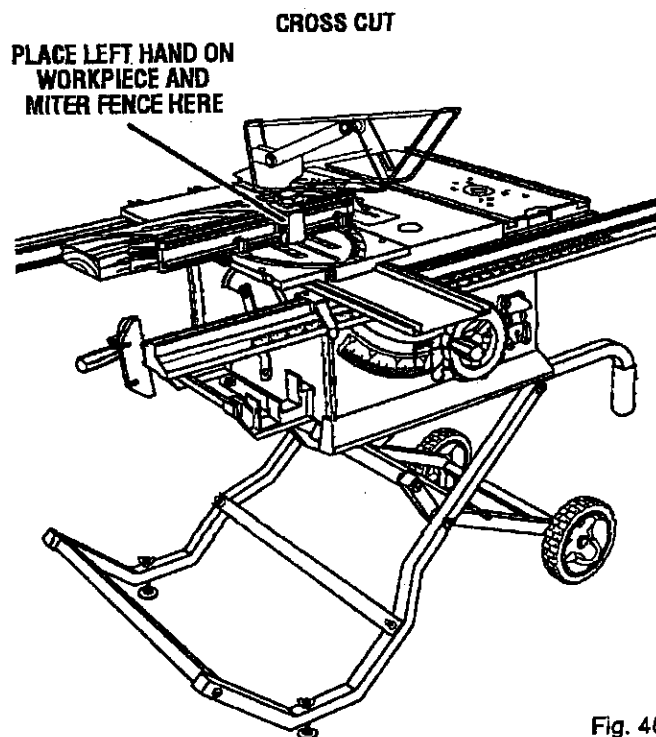

Fig. 40

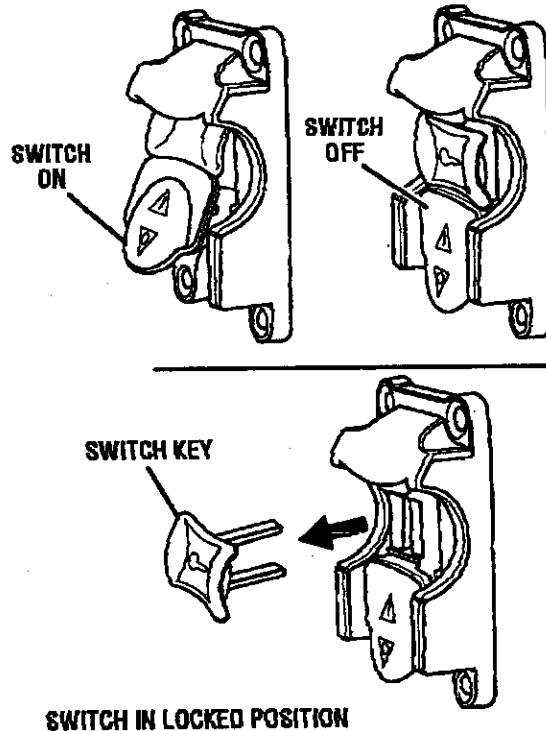

Fig. 41

- Place a support (the same height as saw table) behind the saw for the cut work.
  - Make sure the wood is clear of the blade before turning on the saw.
  - To turn the saw ON, lift the switch button.
  - To turn saw OFF, press the switch button down.
- NOTE:** To prevent unauthorized use, remove the switch key as shown in figure 41.
- Let the blade build up to full speed before moving the workpiece into the blade.
  - Hold the workpiece firmly with both hands on the miter gauge and feed the workpiece into the blade.
  - When the cut is made, turn the saw off. Wait for the blade to come to a complete stop before removing the workpiece.

## MAKING A RIP CUT

See Figure 42.

It is recommended you make a test cut on scrap wood.

**WARNING:** Make sure the blade guard assembly is installed and working properly to avoid serious possible injury.

- Position the rip fence the desired distance from the blade for the cut and securely lock the handle. Adjust the scale to zero at the cutting edge of the blade.

# OPERATION

- Place a support (the same height as saw table) behind the saw for the cut work.
- Make sure the wood is clear of the blade before turning on the saw.
- Use a push block or push stick to move the wood through the cut past the blade. **Never push a small piece of wood into the blade with your hand, always use a push stick.** The use of push blocks, push sticks, and featherboards are necessary when making non-through cuts.
- Stand to the side of the wood as it contacts the blade to reduce the chance of injury should kickback occur. **Never stand directly in the line of cut.**
- Make sure the wood is clear of the blade before turning on the saw.
- Let the blade build up to full speed before feeding the workpiece into the blade.
- When the cut is made, turn the saw off. Wait for the blade to come to a complete stop before removing the workpiece.

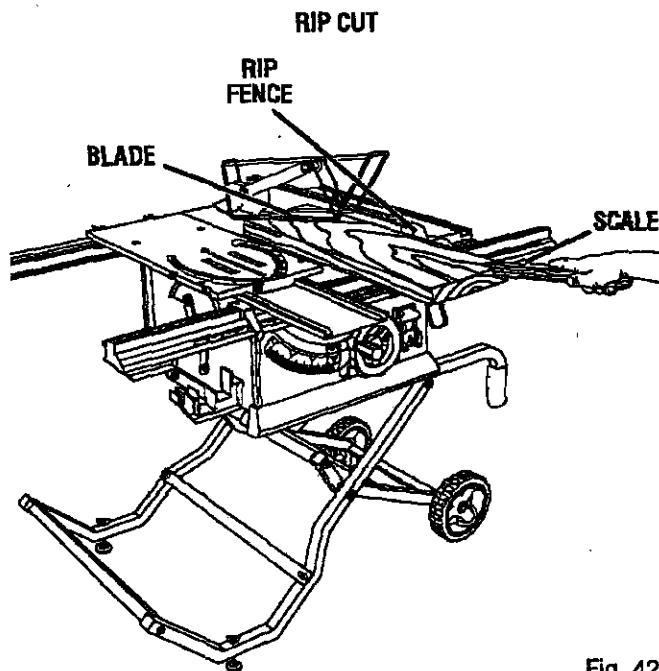

Fig. 42

## MAKING A MITER CUT

See Figure 43.

It is recommended you make test cuts on scrap wood.

**WARNING:** Make sure the blade guard assembly is installed and working properly to avoid serious possible injury.

- Remove the rip fence by lifting the locking handle.
- Set the miter gauge to the desired angle and tighten the lock knob.
- Place a support (the same height as saw table) behind the saw for the cut work.
- Make sure the wood is clear of the blade before turning on the saw.
- Let the blade build up to full speed before moving the workpiece into the blade.
- Feed the workpiece into the blade until the cut has been completed.

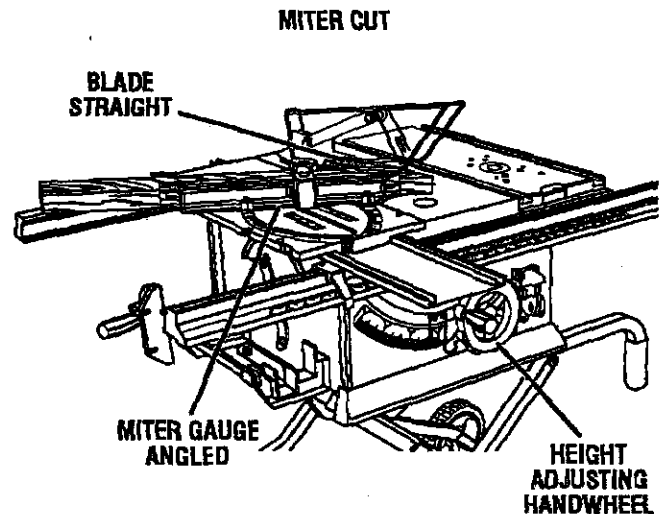

Fig. 43

## MAKING A BEVEL CROSS CUT

See Figures 44 - 45.

It is recommended that you place the piece to be saved on the left side of the blade and that you make a test cut on scrap wood.

**WARNING:** Make sure the blade guard assembly is installed and working properly to avoid serious possible injury.

- Unlock the bevel locking lever.
- Remove the rip fence by lifting the locking handle.
- Turn the height adjusting handwheel until the bevel indicator is at the desired angle. Push the bevel locking lever securely to the left to lock the angle.
- Set the blade to the correct depth for the workpiece.

# OPERATION

VIEWED FROM THE FRONT, BELOW THE TABLE SAW

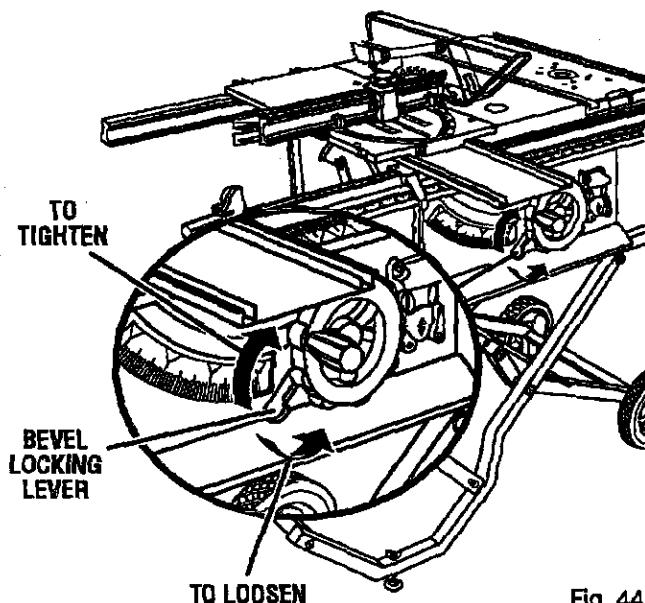

Fig. 44

- Set the miter gauge to 90° and press the bevel locking lever towards the table to lock.
- Place a support (the same height as saw table) behind the saw for the cut work.
- Make sure the wood is clear of the blade before turning on the saw.
- Let the saw blade build up to full speed before moving the miter gauge and the workpiece into the blade.
- Hold the workpiece firmly with both hands on the miter gauge and feed the workpiece into the blade.
- When the cut is made, turn the saw off. Wait for the blade to come to a complete stop before removing the workpiece.

## BEVEL CROSS CUT

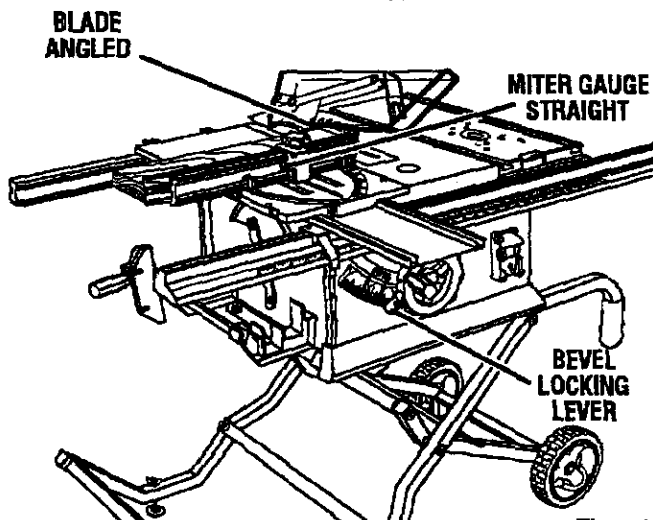

Fig. 45

## MAKING A BEVEL RIP CUT

See Figure 46.

It is recommended you make test cuts on scrap wood.

**▲ WARNING:** The rip fence must be on the left side of the blade to avoid trapping the wood and causing kickback. Placement of the rip fence to the right of the blade will result in kickback and the risk of serious personal injury.

**▲ WARNING:** Make sure the blade guard assembly is installed and working properly to avoid serious personal injury.

- Remove the sliding miter table and move the accessory table to the left side.
- Adjust the bevel angle to the desired setting.
- Set the blade to the correct depth.
- Position the rip fence the desired distance from the left side of the blade and lock down the handle.
- If ripping a piece larger than 36 in. long, place a support the same height as the table surface behind the saw for the cut work.
- Turn the power switch to the **ON** position.
- Position the workpiece flat on the table with the edge flush against the rip fence. Let the blade build up to full speed before feeding the workpiece into the blade.
- Using a push stick and/or push blocks, slowly feed the workpiece toward the blade. Stand slightly to the side of the wood as it contacts the blade to reduce the chance of injury should kickback occur.
- Once the blade has made contact with the workpiece, use the hand closest to the rip fence to guide it. Make sure the edge of the workpiece remains in solid contact with both the rip fence and the surface of the table. If ripping a narrow piece, use a push stick to move the piece through the cut and past the blade.

## OPERATION

- When the cut is made, turn the saw off. Wait for the blade to come to a complete stop before removing the workpiece.
- After the blade has stopped completely, remove the cutoff stock.
- Grasp the workpiece from the lead end (the end fed into the blade first) and carefully remove it from the table.

### BEVEL RIP CUT

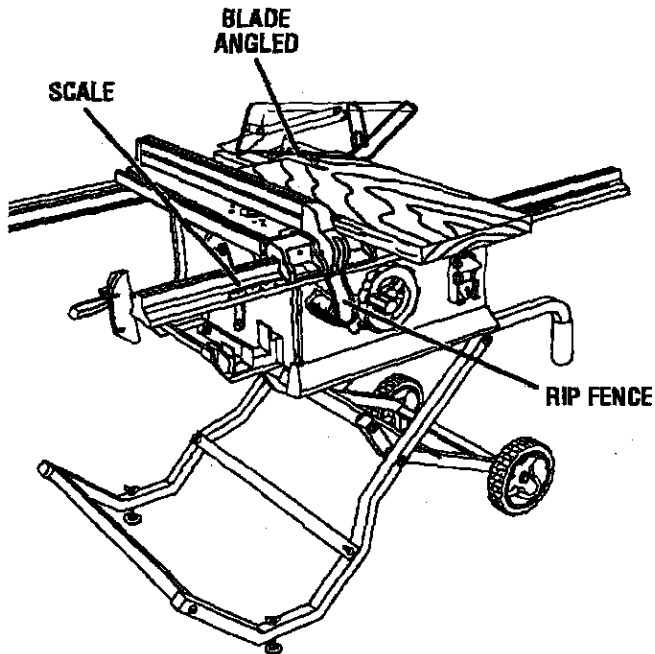

Fig. 46

### MAKING A COMPOUND (BEVEL) MITER CUT

See Figure 47.

It is recommended that you place the piece to be saved on the left side of the blade and that you make a test cut on scrap wood first.

**WARNING:** Make sure the blade guard assembly is installed and working properly to avoid serious possible injury.

- Remove the rip fence by lifting the lock down handle.
- Unlock the bevel locking lever.
- Adjust the bevel angle to the desired setting.
- Lock the bevel locking lever.
- Set the saw blade to the correct depth.

- Loosen the lock knob on the miter gauge, set the miter gauge to the desired angle and tighten lock knob.
- Turn the power switch to the **ON** position.
- Position the workpiece flat on the table with the edge flush against the miter gauge. Let the blade build up to full speed before feeding the workpiece into the blade.
- Advance the workpiece and the miter gauge toward the blade. Keep the workpiece flush against the miter gauge. Push the miter gauge and workpiece toward the blade. Stand slightly to the side of the wood as it contacts the blade to reduce the chance of injury should kickback occur.
- When the cut is made, turn the saw off. Wait for the blade to come to a complete stop before removing the workpiece.
- After the blade has stopped completely, remove the cutoff stock.

### COMPOUND (BEVEL) MITER CUT

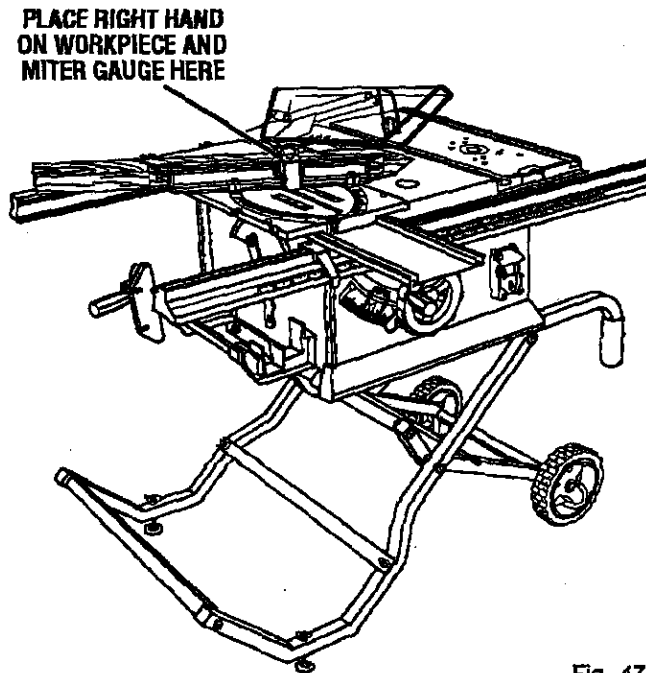

Fig. 47

# OPERATION

## MAKING A LARGE PANEL CUT

See Figure 48.

Make sure the saw is properly secured to a work surface to avoid tipping from the weight of a large panel.

- ▲ **WARNING:** Make sure the blade guard assembly is installed and working properly to avoid serious possible injury.
- Place a support the same height as the top of the saw table behind the saw for the cut work. Add supports to the sides as needed.
- Depending on the shape of the panel, use the rip fence or miter gauge. If the panel is too large to use either the rip fence or the miter gauge, it is too large for this saw.

- ▲ **WARNING:** Never make freehand cuts (cuts without the miter gauge or rip fence), which can result in serious injury.
- Make sure the wood does not touch the blade before you turn on the saw. Let the blade build up to full speed before feeding the wood into the blade.
- When the work is completed, press the switch off and remove the key.

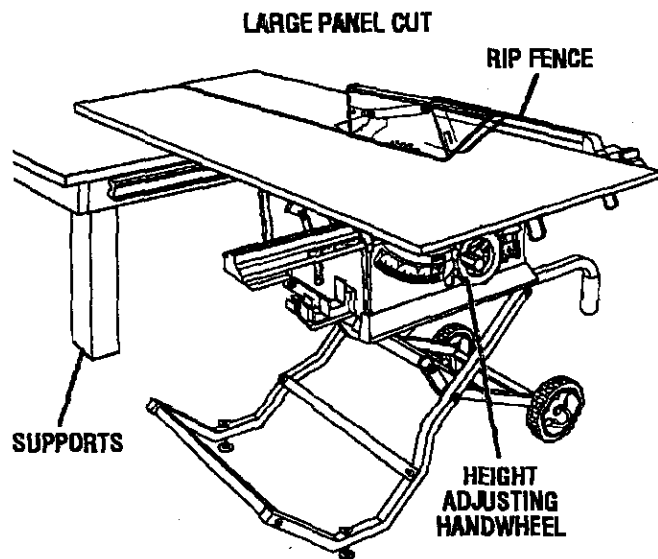

Fig. 48

## MAKING A NON-THROUGH CUT

See Figure 49.

Non-through cuts can be made with the grain (ripping) or across the grain (cross cut). The use of a non-through cut is essential to cutting grooves, rabbets, and dados.

**NOTE:** This is the only type cut that is made without the blade guard installed. Make sure the blade guard assembly is reinstalled upon completion of this type of cut.

Read the appropriate section which describes the type of cut in addition to this section on non-through or dado cuts. For example, if your non-through cut is a straight cross cut, read and understand the section on straight cross cuts before proceeding.

- Unplug the saw.
  - Lower the blade and remove the screw holding the throat plate in place. Remove the throat plate.
  - Raise the saw blade.
  - Put the saw in angle mode by pushing the bevel locking lever to the right. Turn the height adjusting handwheel until the blade indicator shows a 30° angle. Push the bevel locking lever securely to the left to lock the angle.
  - Loosen the two hex nuts at the base of the riving knife. Do not remove hex nuts. Remove the riving knife/blade guard assembly. Retighten the two hex nuts on the base.
  - Lower the blade and insert the throat plate, then securely tighten the throat plate screw.
  - Bring the blade back to 90°.
  - Raise the blade to the correct height by turning the height adjusting handwheel counterclockwise.
- NOTE:** Carefully check all setups and rotate the blade one full revolution to assure proper clearance before connecting saw to power source.
- Feed the workpiece into the blade.
  - Always use push blocks, push sticks, and featherboards when making non-through cuts to avoid the risk of serious injury.

- ▲ **WARNING:** When making a non-through cut, the cutter is covered by the workpiece during most of the cut. Be alert to the exposed cutter at the start and finish of every cut to avoid the risk of personal injury.

# OPERATION

**⚠ WARNING:** Never feed wood with your hands when making any non-through cut such as rabbets or dados. To avoid personal injury, always use push blocks, push sticks, and featherboards.

- When the cut is made, turn the saw **OFF**. Wait for the blade to come to a complete stop before removing the workpiece.
- Unplug the saw.
- Lower the blade and remove the screw holding the throat plate in place. Remove the throat plate.
- Raise the saw blade.
- Push the bevel locking lever to the right. Rotate the height adjusting handwheel until the bevel indicator shows a 30° angle. Push the bevel locking lever securely to the left while holding the height adjusting handwheel to lock the angle. Reinstall the blade guard assembly.
- Retighten the nuts at the base of the riving knife. Check riving knife alignment to the blade and adjust shims if necessary.
- Move the bevel locking lever to the right and rotate the blade back to 90°. Push the lever to the left to lock the angle.
- Lower the blade, insert the throat plate, then securely tighten the throat plate screw.

## NON-THROUGH CUT

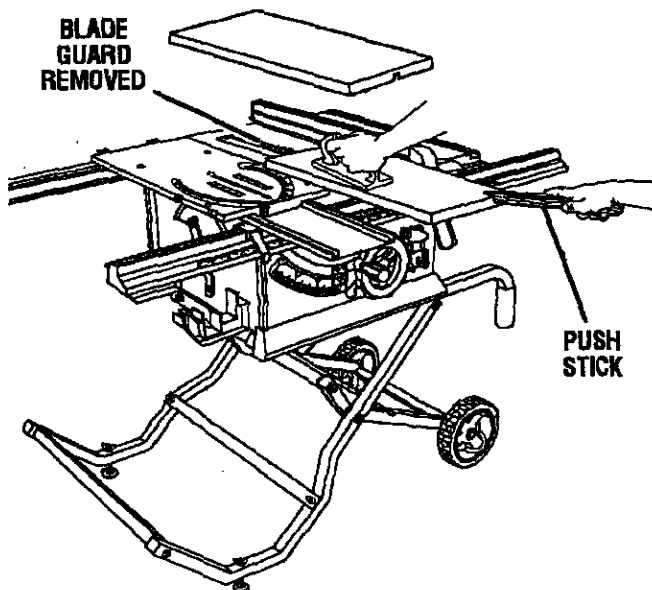

Fig. 49

## MAKING A DADO CUT

See Figure 50.

An optional dado throat plate is required for this procedure (max. dado width 13/16 in.). See the *Accessories* section of this manual and check with your nearest Sears retail. Do not use blades rated less than the speed of this tool.

**NOTE:** This saw cannot be used to make a bevel dado cut.

- Unplug the saw.
- Remove the blade guard assembly.
- Retighten the two hex nuts.
- Remove the saw blade.
- Remove the inner blade washer and both the small and large spacers.
- Add the small spacer then the inner blade washer to the blader arbor.
- Mount the dado blade, using the blade and chippers appropriate for the desired width of cut.
- Reinstall the arbor nut.
- Make sure the arbor nut is fully engaged and the arbor extends at least one full thread past a securely tightened arbor nut.

**⚠ WARNING:** Always put all spacers in proper location when changing back to saw blade. Failure to do so may result in possible injury and damage to the tool.

**⚠ WARNING:** Always use push blocks, push sticks, or featherboards when making dado cuts to avoid the risk of serious injury.

## DADO CUT

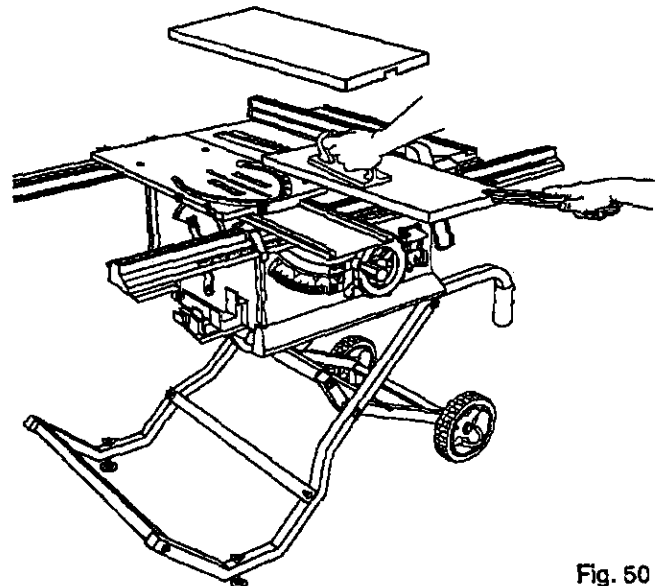

Fig. 50

# OPERATION

## ACCESSORY TABLE USAGE

This accessory table has been specifically designed for use with listed Craftsman Routers. The hole pattern on the accessory table has *not* been drilled to accommodate all routers. Routers must not exceed 3 HP (maximum developed) or weigh more than 12-1/2 lbs. Routers must have lock-on switch feature.

## TABLE CLAMPING BRACKET

See Figure 51.

The lever on the accessory table will tighten the table securely to the front rail. The weight of the router may cause the accessory table to loosen or have movement at the rear of the table. To avoid this, install the table clamping bracket.

**NOTE:** Position the table clamping bracket so that the accessory table is centered over it.

- Slide one of the T-nuts into the front channel of the rear rail and under the accessory table.
- The table clamping bracket fits in the bottom slot of the rear rail and the slotted top of the bracket wraps around the raised portion on the underside of the accessory table.
- Secure with a 5/16 in. washer and a 5/16-18 x 3/4 in. knob bolt.
- Tighten the knob bolt securely.

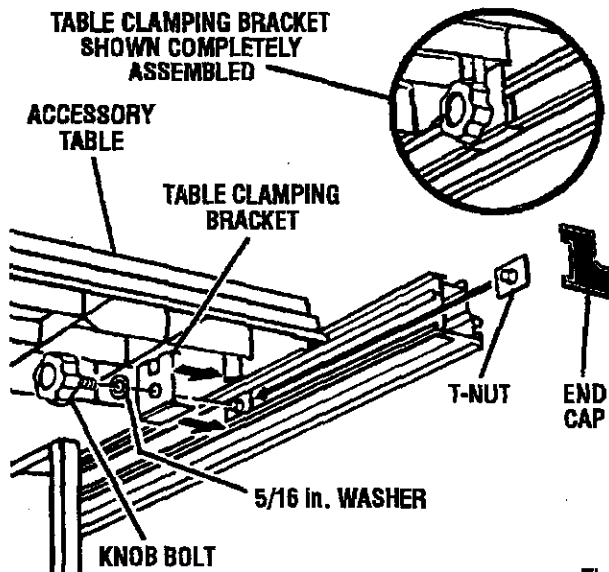
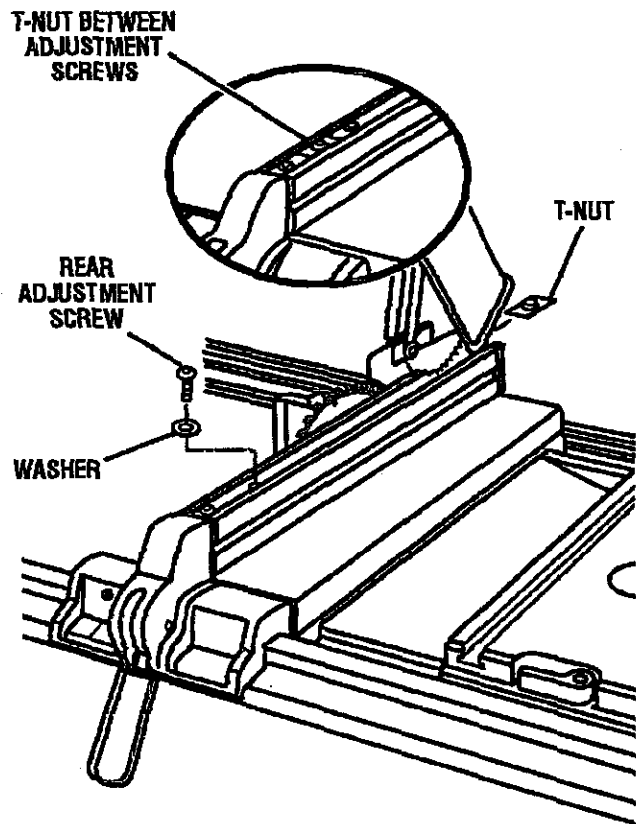

Fig. 51



RIP FENCE SHOWN LOCKED AGAINST SAW BLADE

Fig. 52

## TO INSTALL T-NUTS FOR GUIDE FENCE BRACKETS

See Figures 52 - 53.

- Place rip fence against blade and lock in place.
- Using the appropriate hex key supplied with your table saw, remove the rear adjustment screw and washer on top of the rip fence.
- Slide one of the T-nuts into the top channel of rip fence and place between the two adjustment screws.  
**NOTE:** T-nuts install from the rear of the rip fence.
- Replace the washer and the rear adjustment screw and tighten securely.
- Check the rip fence for squareness with the saw blade.
- Unlock the rip fence, slide it away from the saw blade, and lock it in place.
- Slide the four remaining T-nuts into the top channel of rip fence.

**NOTE:** Five T-nuts should be in the top channel of the rip fence with only one of them between the adjustment screws on the rip fence.

## OPERATION

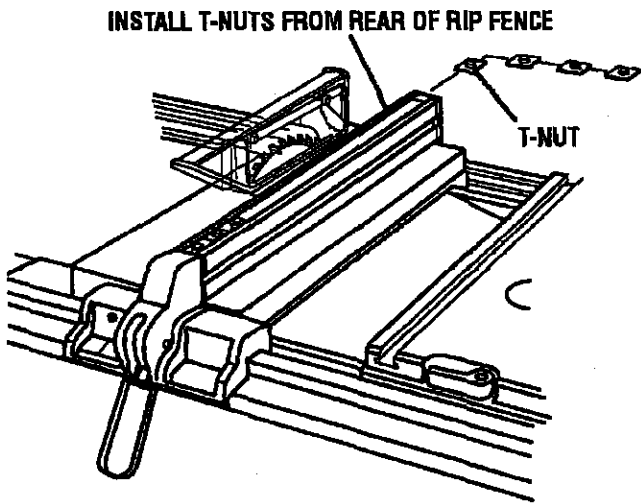

Fig. 53

### TO INSTALL GUIDE FENCE BRACKETS

See Figure 54.

- To install the guide fence brackets, align each bracket with two of the T-nuts on top of the rip fence.

**NOTE:** Use the front two T-nuts and the back two T-nuts leaving the one in the middle empty.

- Secure the guide fence brackets to the rip fence with 5/16 in. washers and the 5/16 in. x 1/2 in. knob bolts.

### TO INSTALL POST, GUARD/DUST COVER WITH PIVOT ASSEMBLY

See Figure 54.

The guard/dust cover must be used in all routing operations.

- Place the spacer on the threaded end of the post and thread the post into the remaining T-nut.
- Tighten the post securely with an adjustable wrench on the flats on the top of the post.
- Place the guard/dust cover with pivot assembly on the post.
- The assembly will slide up and down on the post as needed. Secure at the desired location by tightening the knob nut attached to the carriage bolt.

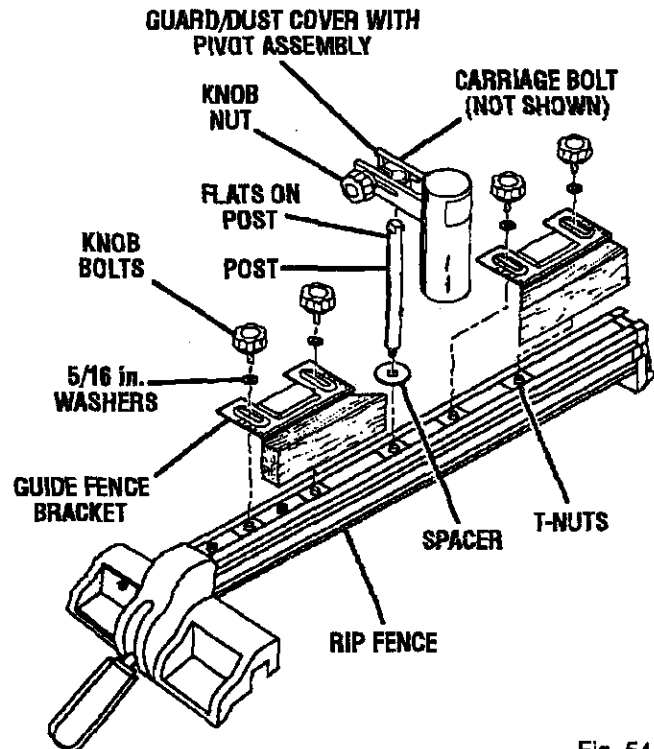

Fig. 54

# OPERATION

## TO INSTALL ROUTER

See Figure 55.

- Unplug the router.
- Place your router upside down on a workbench.
- Remove the subbase screws and the subbase from your router.  
**NOTE:** The subbase is mounted permanently on some routers and should not be removed.
- Select the screws needed for your particular router. For consumer routers, use the 10-32 x 3/4 in. screws. For commercial routers, use the 5/16-18 screws.
- Position router upside down under the router extension table. The router label should be facing the front of the table.
- Align the holes in the table with the holes in your router. Feed the screws through the table and into the router.
- Tighten all screws with a screwdriver.

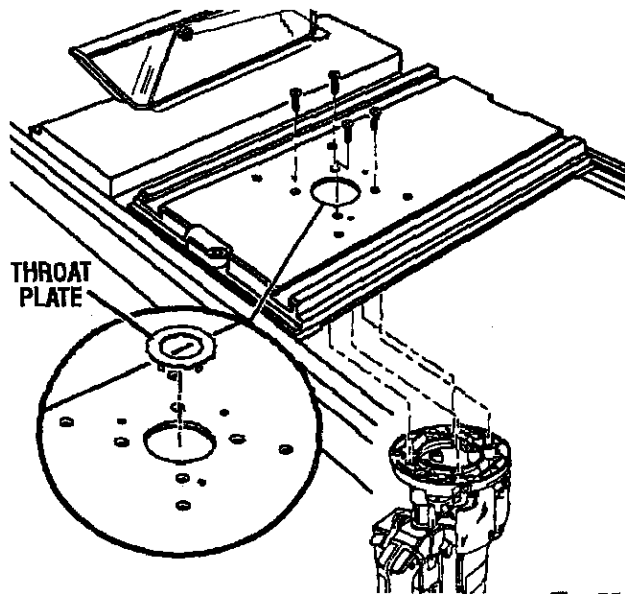

Fig. 55

## TO INSTALL BIT AND THROAT PLATE

The router throat plates are included to assure no more than 1/4 in. clearance between the cutter and the opening in the throat plate. Use the correct throat plate. Do not use a router bit smaller than 1/4 in. or larger than 2 in.

- To install the router bit, follow the instructions in the operator's manual that came with your router.

**CAUTION:** Make sure the router bit will not strike the accessory table or any metal surface.

- Select the correct size throat plate for the size of the router bit. Align the tab on the throat plate with the slot in the router extension and snap in place. Make sure the throat plate is firmly seated below the table surface. Recheck the router bit to make sure it will not strike the throat plate.

## FINAL PREPARATION FOR OPERATION

See Figure 56.

- Adjust the guard/dust cover so that it will not come in contact with the workpiece or cutter during a cutting operation.
- Direction of feed of the workpiece is from right to left or from the back of the saw toward the front with the bit located in the fence opening.

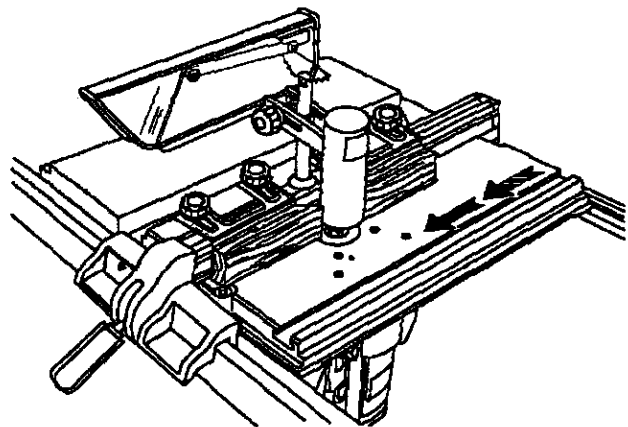

Fig. 56

- Direction of feed must always be so that the workpiece is being thrust against the sharp edges of the rotating bit.
- The workpiece must always be tight against the guide fence, unless a ball-bearing piloted bit is being used. The infeed fence should be adjusted to support the uncut workpiece while the outfeed fence should be adjusted properly to support the workpiece after the cut passes the router bit, compensating for the removed stock.

**WARNING:** The direction of feed for the workpiece is always against the sharp edges of the bit and against the rotation of the cutter. Failure to heed this warning is likely to result in serious personal injury.

**WARNING:** Do not use the guide fence with ball-bearing piloted bits. Failure to heed this warning may result in serious personal injury.

## ADJUSTMENTS

**WARNING:** Before performing any adjustment, make sure the tool is unplugged from the power supply. Failure to heed this warning could result in serious personal injury.

**WARNING:** Blades coast after turn off. Possible serious injury can occur if hands come in contact with blade.

The table saw has been adjusted at the factory for making very accurate cuts. However, some of the components might have been jarred out of alignment during shipping. Also, over a period of time, readjustment will probably become necessary due to wear.

To avoid unnecessary setups and adjustments, a good practice is to check your setups carefully with a framing square and make practice cuts in scrap wood before making finish cuts in good workpieces. Do not start any adjustments until you have checked with a square and made test cuts to be sure adjustments are needed.

### TO REPLACE THE BLADE

See Figures 57 - 59.

- Unplug the saw.
- Lower the saw blade, raise the blade guard, and remove the throat plate.
- Make sure the bevel locking lever is securely pushed to the left. Raise the saw blade to its full height by turning the height/bevel adjusting handwheel clockwise.
- Using the small blade wrench, insert the flat open end into the flats on the arbor shaft.
- Insert the closed end of the large blade wrench over the hex nut. Holding both wrenches firmly, pull the larger wrench forward to the front of the machine. Make sure the blade nut is securely tightened. Do not overtighten.

**NOTE:** Arbor shaft has left hand threads.

Check all clearances for free blade rotation. See **To Set the Scale to the Blade** in this section. In cutting operations, the scale will be set to the side of the blade where the cut will be measured and made.

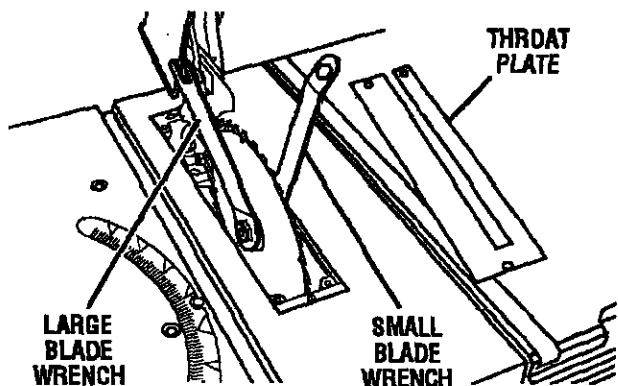

Fig. 57

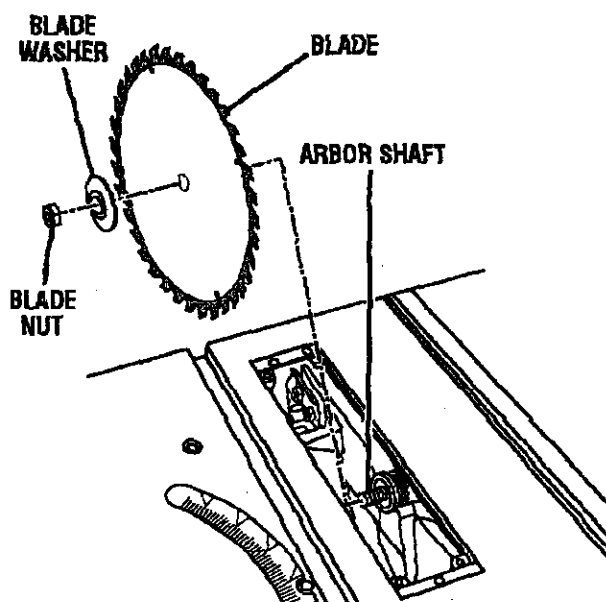

Fig. 58

To replace the blade with an accessory blade, follow the instructions provided with the accessory.

### To install a standard blade:

- Place the new blade on the arbor shaft (the teeth must point down toward the front of the saw to work properly).
- Place the blade washer and the blade nut over the blade arbor. Be sure the dome side of the blade washer faces out from the blade and that all items are snug against the arbor housing. Tighten securely.
- Rotate the blade by hand to make sure it turns freely.
- Reinstall the throat plate.

**NOTE:** Securely tighten throat plate screws. Do not allow the throat plate to bow up above the table surface.

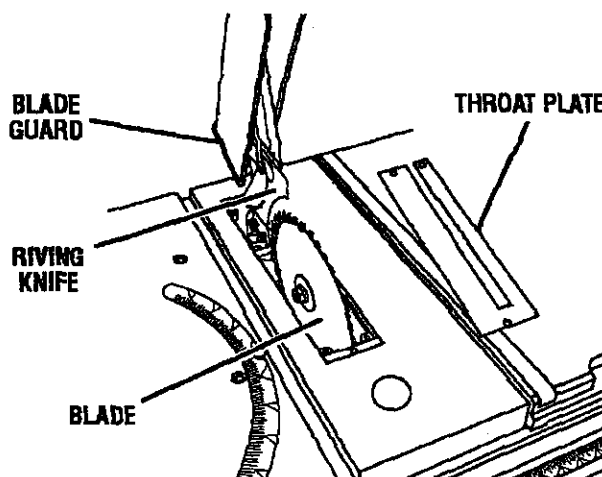

Fig. 59

## ADJUSTMENTS

### TO CHECK, REPLACE, OR ADJUST THE RIVING KNIFE AND BLADE GUARD ASSEMBLY

See Figures 60 - 61.

**WARNING:** Properly align riving knife. Improperly aligned riving knife may cause blade to bind which will increase risk of kickback.

The riving knife is mounted between several shims that can be relocated as needed to center the knife behind the blade. It is held in place by two bolts and hex nuts at its base. The bolts are set in slots that permit front-to-back adjustment.

#### To check alignment of the riving knife:

- Unplug the saw.
- Raise the saw blade by turning the height/bevel adjusting handwheel counterclockwise.
- Lift the anti-kickback pawls and place a framing square or straight edge against both the saw blade and the riving knife.
- The saw blade and riving knife are aligned when the framing square contacts both the blade and riving knife evenly with no gaps.

#### If the riving knife and saw blade are not in alignment, adjustment is needed. To adjust:

- Unplug the saw and raise the blade guard assembly.
- Remove the throat plate and the blade guard assembly.
- Move the shims to bring the riving knife into alignment with the saw blade.

**NOTE:** It may be necessary to remove the shims and turn them in an opposite direction.

- Reinstall the riving knife between the shims.
- Recheck the alignment by placing the framing square beside the saw blade as explained above.

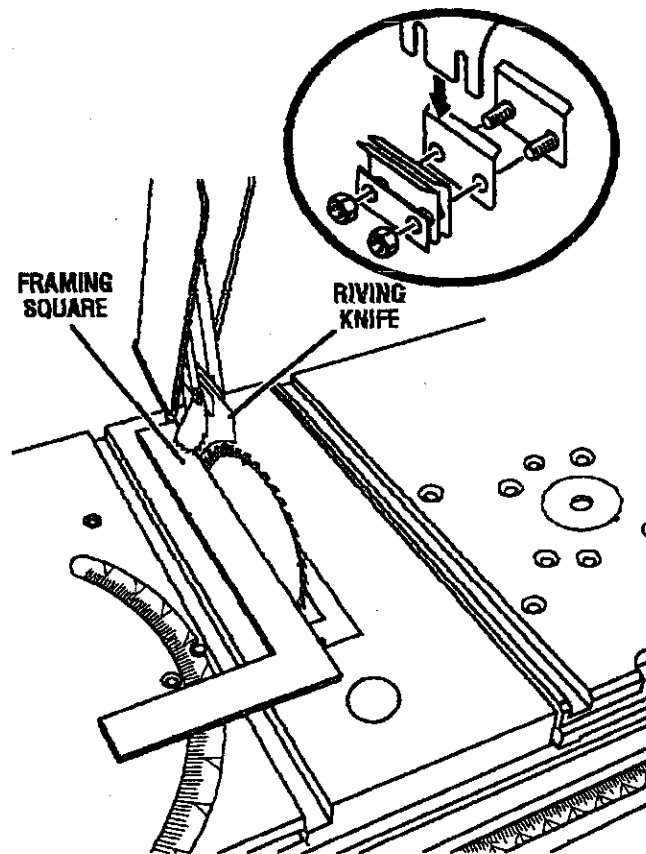

Fig. 61

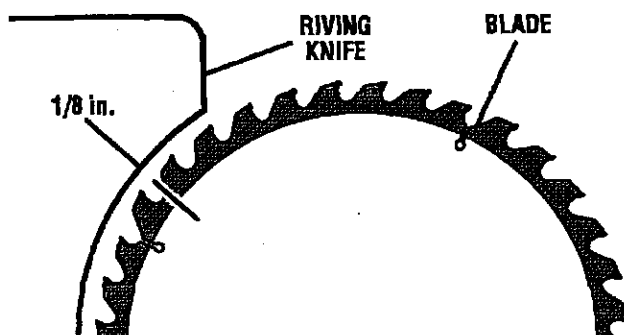

Fig. 60

# ADJUSTMENTS

## TO SET THE BEVEL INDICATOR AND BEVEL STOPS AT 0° AND 45° (SQUARING THE BLADE)

See Figure 62.

The angle settings of the saw have been set at the factory and, unless damaged in shipping, should not require setting during assembly. After extensive use, it may need to be checked.

- Unplug the saw.
- Push the bevel locking lever to the right. Turn the height/bevel adjusting handwheel to angle the blade. Use a combination square to check squareness between the blade and saw table.
- If the blade is not perfectly vertical (0°), loosen the lock nut on the 0° bolt inside the cabinet, position the blade, adjust the bolt, then retighten lock nut. See Figure 62, insert. If the bevel indicator is not at zero, adjust it with the two screws above the slot, beside the height/bevel adjusting handwheel.
- Turn the height/bevel adjusting handwheel until the bottom of the blade has moved completely to the left side of the slot. Lock the angle by pushing the bevel locking lever to the left.

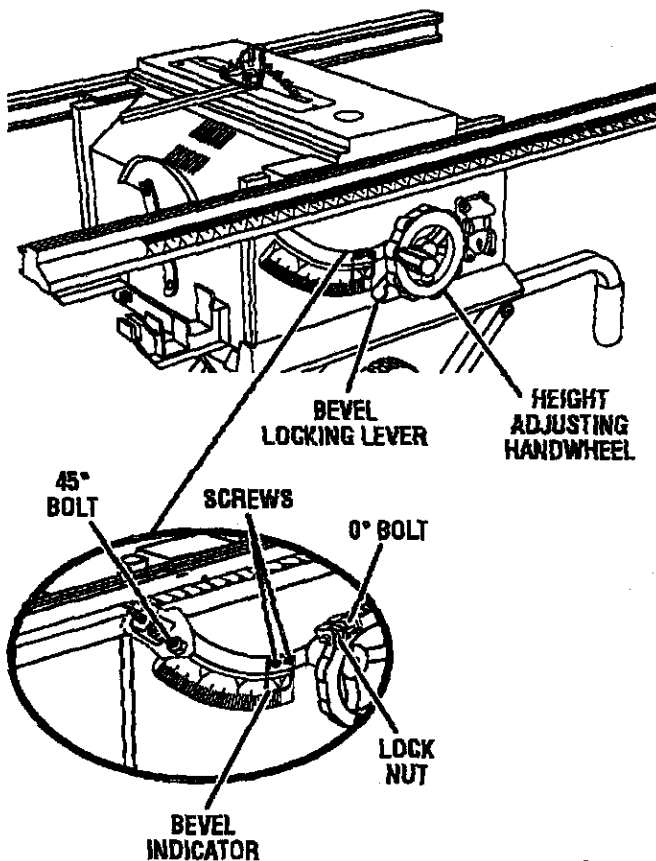

Fig. 62

- If the blade is not an exact 45°, loosen the lock nut on the 45° bolt inside the cabinet, position the blade, adjust the bolt, then retighten lock nut.
- Make a test cut.

## TO ADJUST THE MITER GAUGE

See Figure 63.

You can set the miter gauge at 0° and plus or minus 45° with the miter gauge stop pin and adjustable stop screws.

**NOTE** The miter gauge provides close accuracy in angled cuts. For very close tolerances, test cuts are recommended.

- Loosen knob and pull out on stop pin to rotate miter gauge base past stop screws.
- Loosen the lock nut of the 0° stop screw at the stop pin with a 8 mm wrench.
- Place a 90° square against the miter gauge rod and the miter gauge base.
- If the rod is not square, loosen the knob, adjust the rod, and tighten the knob.
- Adjust the 0° stop screw until it rests against the stop pin.
- Adjust the plus and minus 45° stop screws using a 45° triangle and the steps above.

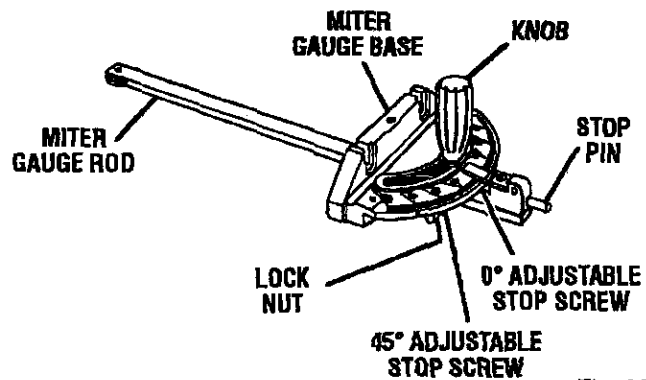

Fig. 63

# ADJUSTMENTS

## TO CHECK THE ALIGNMENT OF THE RIP FENCE TO THE BLADE

See Figure 64.

- Unplug the saw.
- Raise the locking handle to permit the rip fence to be moved.

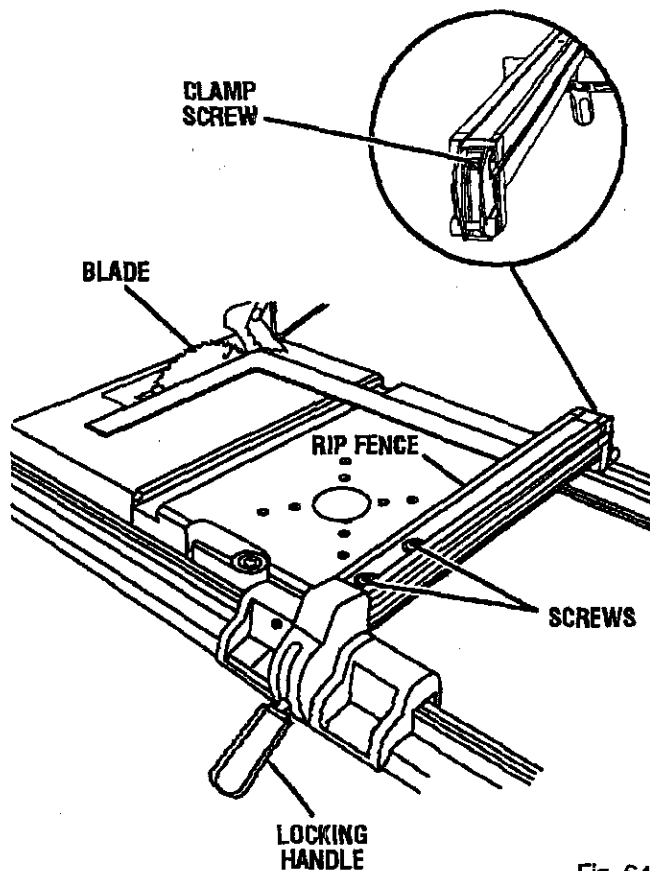

Fig. 64

- Place a framing square beside the blade and move the rip fence up to the square. Take the dimension on the rip scale.
- Move the fence back and turn the framing square 180° to check the other side.
- If the two dimensions are not the same, loosen the two screws on the fence and align it.
- Retighten the two screws.
- Make two or three test cuts on scrap wood. If the cuts are not true, repeat the process.

**NOTE:** The rip fence must be secure when the locking handle is engaged. The clamp screw on the rear of the rip fence is tightened by turning clockwise to increase tightness of the rear of the rip fence.

## TO ADJUST THE BEVEL LOCKING LEVER

See Figure 65.

The bevel locking lever may work loose and require adjusting. To adjust:

- Unplug the saw.
- Push the lever full left to the locked position.
- Remove the screw on the height/bevel adjusting handwheel. You will need the 3/16 in. hex key for this procedure.
- Remove the height/bevel adjusting handwheel and cam. Pull out the cam.
- Remove the set screw on the bevel locking lever.
- Remove the bevel locking lever from hex nut.
- Relocate bevel locking lever on the hex nut.
- Replace set screw and tighten securely.
- Replace the cam so that the lobe is against the tab. Make sure the cam is seated in the lever.
- Reassemble the height/bevel adjusting handwheel to the shaft and cam. Check whether the lever is now in the desired position. Tighten screw securely.

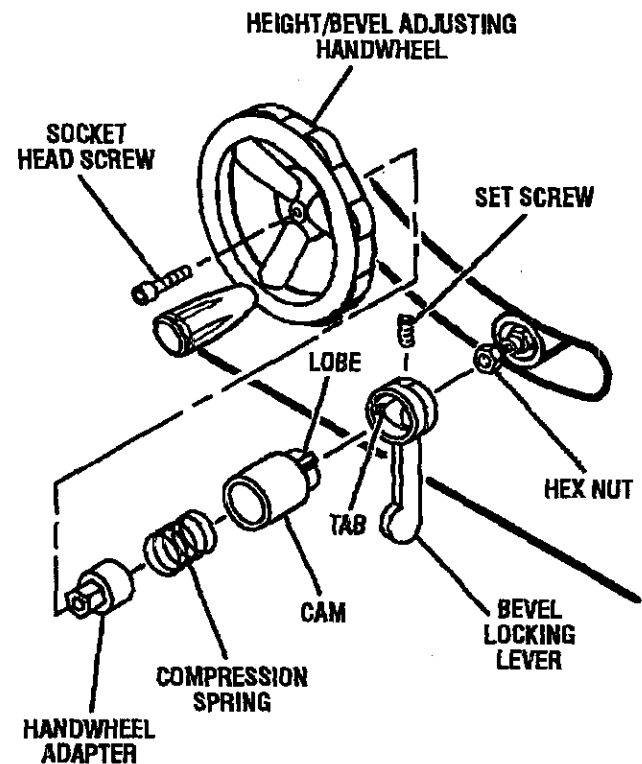

Fig. 65

# ADJUSTMENTS

## TO ALIGN THE MITER LOCKING CLAMPS

See Figure 66.

The miter locking clamps are preset at the factory but may require adjusting after extended use or if damage occurs in shipping.

- Unplug the saw.
- Loosen the set screw behind each locking clamp.
- Loosen the screw on top of each locking clamp.
- Lift the locking clamp to the up position.
- Push the clamp forward tight against the front rail to bring the clamp into alignment.
- When the clamps are correctly positioned, retighten the screws and the set screws.
- Push both front and rear miter locking clamps down to secure the sliding miter table.

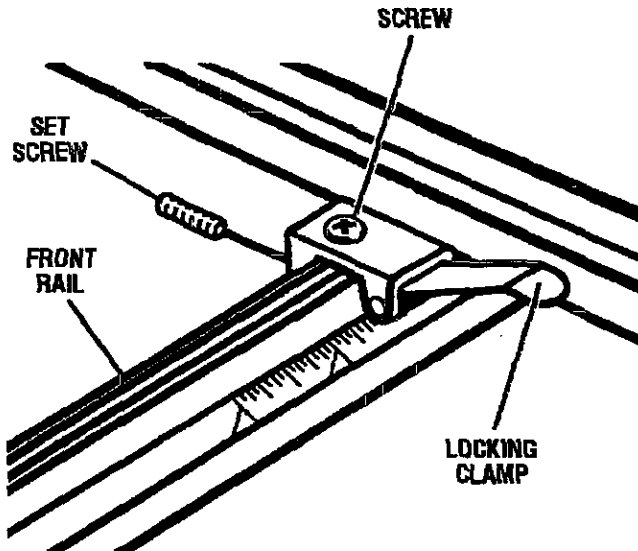

Fig. 66

## TO ADJUST THE FRONT AND REAR RAIL CLAMPS

See Figure 67.

The rail clamps are located below the rails and ensure tight attachment of the rail. Following extended use, the rail holder nut inside the rails may need adjusting.

- Unplug the saw.
- Remove the miter table and accessory table.
- Remove the front and rear rails by loosening the rail clamps and sliding the rails off.
- Rotate each rail clamp to the left until it hits or comes in contact with the bottom of the saw table.
- Tighten rail holder nut until it is snug.
- Loosen rail holder nut one-fourth (1/4) turn.
- Replace the rails and check the rail clamps.

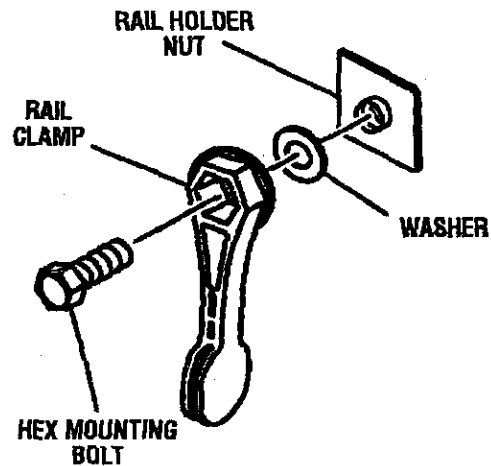

Fig. 67

## TO ADJUST THE ACCESSORY TABLE

See Figure 68.

After extended use, the accessory table may work loose causing the accessory table to be loose on the rails. Follow the steps below, when adjustments are required:

- Unplug the saw.
- Remove the hex nut on the lever using a 3/8 in. nut driver.
- Remove the backup plate and spring plate. Rotate the spring plate 180° and reinstall on the handle shaft.
- Reassemble all parts and tighten hex nut securely.

**NOTE:** The spring plate offers two ends for use before requiring replacement.

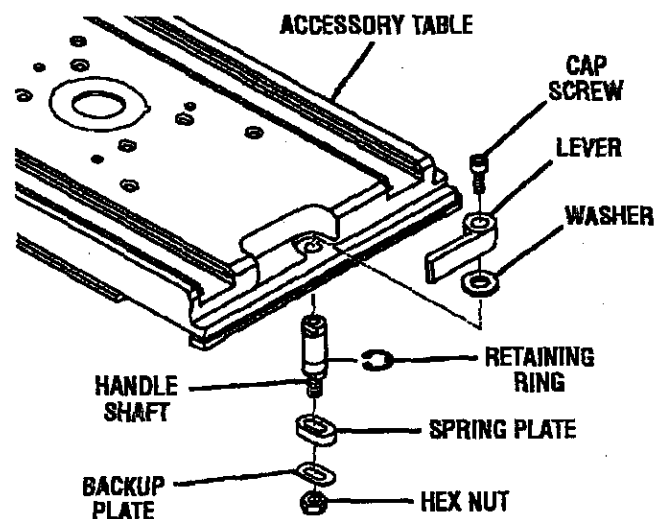

Fig. 68

# MAINTENANCE

**WARNING:** When servicing, use only identical replacement parts. Use of any other parts may create a hazard or cause product damage.

**WARNING:** Always wear safety goggles or safety glasses with side shields during power tool operation or when blowing dust. If operation is dusty, also wear a dust mask.

## GENERAL

Avoid using solvents when cleaning plastic parts. Most plastics are susceptible to damage from various types of commercial solvents and may be damaged by their use. Use clean cloths to remove dirt, dust, oil, grease, etc.

**WARNING:** Do not at any time let brake fluids, gasoline, petroleum-based products, penetrating oils, etc., come in contact with plastic parts. Chemicals can damage, weaken, or destroy plastic which may result in serious personal injury.

- Periodically check all clamps, nuts, bolts, screws, and belts for tightness and condition. Make sure the throat plate is in good condition and in position.
- Check the blade guard assembly.
- To maintain the table surfaces, fence, and rails, periodically apply paste wax to them and buff to provide smooth functioning. To prevent work from slipping during cutting operation, **Do not wax** the working face of the miter fence.
- Protect the blade by cleaning out saw dust from underneath the table and in the blade teeth. Use a resin solvent on the blade teeth.
- **Clean plastic parts only with a soft damp cloth. Do not use any aerosol or petroleum solvents.**

## LUBRICATION

This saw has been lubricated at the factory prior to shipment. Following extended use, you should inspect and lubricate the following areas to assure smooth operation.

## LOCKER BRACKET ASSEMBLY

See Figure 69.

- Add dry lube between both bevel gears, the backup washers, and the locker bracket.
- Add dry lube between threaded hole in motor casting and threaded elevating shaft.

Recommended Lubricants: Dry Silicone or Teflon Lubricant

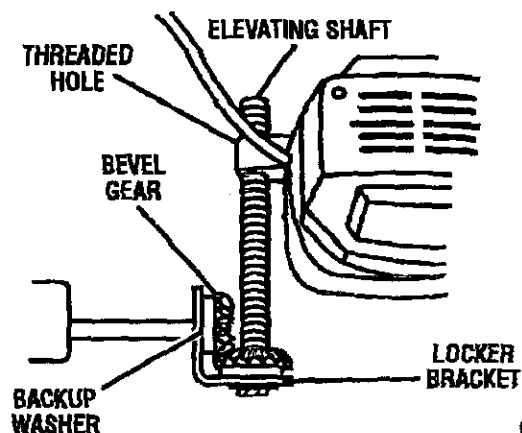

Fig. 69

## TILT/ELEVATING MECHANISM

See Figure 70.

- Add dry lube between the handle shaft and the bore of the clamping bolt.
- Add dry lube between the face of the clamping bolt and the face of the handle shaft.
- Add dry lube on the inner surfaces of the bevel locking lever which contacts the cam.

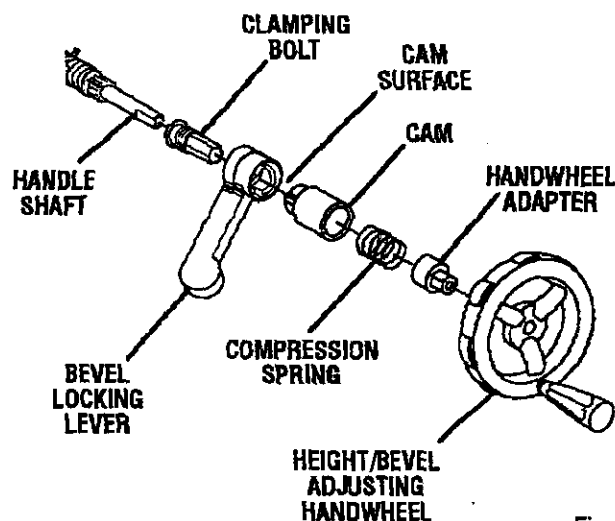

Fig. 70

## ACCESSORIES

Look for these accessories at Sears retail:

Item No. 9-22212 4070331	Zero Clearance Throat Plate Dado Throat Plate
Item No. 9-22214	Micro-Position Rip-Fence Accessory
Item No. 9-22215	Quick Fold Table
Item No. 9-22217	Long Miter/Rip Fence
Item No. 9-22220	Miter Clamp Kit

**⚠ WARNING:** To avoid risk of injury, use recommended dado and zero clearance throat plate when employing a dado accessory.

- **ONLY USE 6 IN. STACK DADOES.**
- **NEVER BEVEL DADO.**
- **NEVER USE ADJUSTABLE DADOES ON THIS SAW.**

## TROUBLESHOOTING

PROBLEM	CAUSE	SOLUTION
Excess vibration.	Blade is out of balance.	Replace blade.
	Blade is damaged.	Replace blade.
	Saw is not mounted securely.	Tighten all hardware.
	Work surface is uneven.	Reposition on flat surface. Adjust legs of optional stand.
	Blade is warped.	Check Saw Blade Installation. Replace blade if necessary
Rip fence does not move smoothly.	Rip fence not mounted correctly.	Remount the rip fence.
	Rails are dirty or sticky.	Clean and wax rails.
	Clamp screw is out of adjustment.	Adjust clamp screw counterclockwise.
Rip fence does not lock at rear.	Clamp screw is out of adjustment.	Adjust clamp screw clockwise.
Cutting binds or burns work.	Blade is dull.	Replace or sharpen blade.
	Blade is heeling.	Align miter base.
	Work is fed too fast.	Slow the feed rate.
	Rip fence is misaligned.	Align the rip fence.
	Living knife is misaligned.	Adjust the living knife with shims provided.
	Wood is warped.	Replace the wood. Always cut with convex side to table surface.

# TROUBLESHOOTING

PROBLEM	CAUSE	SOLUTION
Wood edges away from rip fence when ripping.	Rip fence is misaligned. Blade not properly sharpened or set.	Check and adjust the rip fence. Resharpener or set blade.
Sliding miter table assembly does not move smoothly.	Miter base or slides improperly adjusted.	See page 26 for adjustments to sliding miter table assembly.
Saw does not make accurate 90 or 45 degree cuts.	Positive stops inside cabinet need adjusting (Bevel Cuts). Miter gauge is misaligned (Miter Cuts).	Adjust positive stops. Adjust the miter gauge.
Blade adjusting handle is hard to turn.	Gears or Screw Post inside cabinet are clogged with saw dust.	Clean the gears or screw post.
Saw does not start.	Motor cord or wall cord is not plugged in. Circuit fuse is blown. Circuit breaker is tripped. Cord or switch is damaged.	Plug in motor cord or wall cord. Replace circuit fuse. Reset circuit breaker. Have the cord or switch replaced at your Sears Service Center/Department.
Blade makes poor cuts.	Blade is dull or dirty. Blade is wrong type for cut being made. Blade is mounted backwards.	Clean, sharpen, or replace blade. Replace with correct type. Remount blade.
Blade does not lower when turning blade adjusting handle.	Back side of riving knife has come in contact with saw table. Locking lever is not at full left position.	Realign and adjust the riving knife. Move locking lever to left.
Motor labors in rip cut.	Blade not proper for rip cut.	Change blade; rip blade typically has fewer teeth.

CRAFTSMAN 10 in. TABLE SAW - MODEL NO. 315.218290

FIGURE A: 10 in. TABLE SAW

FOR MITER TABLE ASSEMBLY,  
REFER TO FIGURE B

FOR HEIGHT/BEVEL ADJUSTMENT  
HANDWHEEL, REFER TO FIGURE D

FOR RIP FENCE ASSEMBLY,  
REFER TO FIGURE C

FOR LEG STAND ASSEMBLY,  
REFER TO FIGURE G

FOR MITER GAUGE,  
REFER TO NOTE F

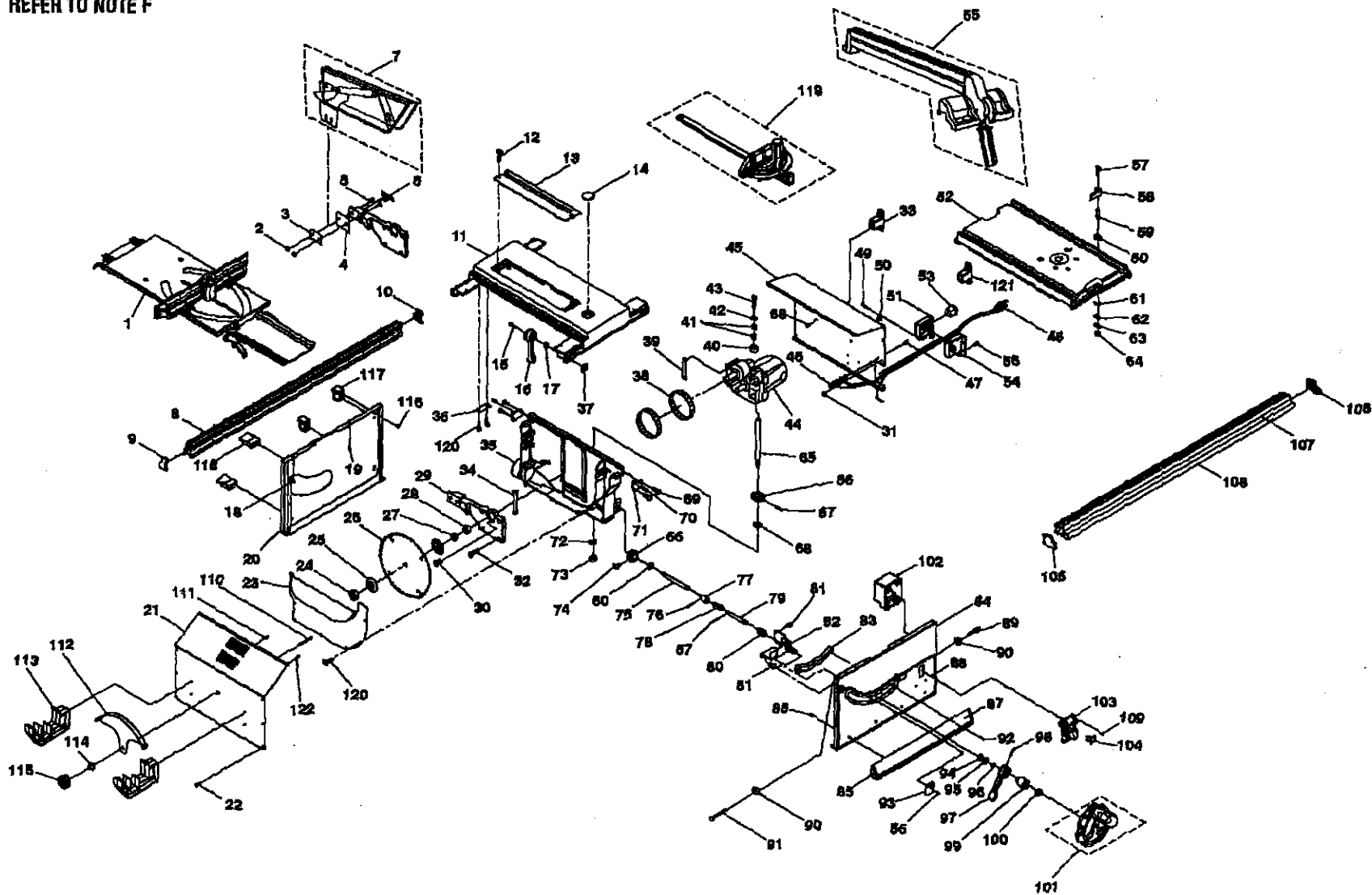

48



## CRAFTSMAN 10 in. TABLE SAW – MODEL NO. 315.218290

### PARTS LIST – FIGURE A

The model number will be found on a plate attached to the side panel of the cabinet. Always mention the model number in all correspondence regarding your **TABLE SAW** or when ordering repair parts.

Key Part No. Number	Description	Qty.	Key Part No. Number	Description	Qty.		
1	A182012001	Miter Table Assembly.....	1	35	0181010106	Locker Bracket .....	1
2	411011710	*Hex Nut (5/16-18) .....	2	36	0181010323	Clamp Plate .....	2
3	0181010321	Clamp .....	1	37	0181010317	Rail Holder Nut .....	4
4	0181010343	Shim.....	5	38	424010003	V-Belt (106H9 Bando).....	2
5	410011721	*Screw (5/16-18 x 1-1/8 in., Hex Hd.).....	2	39	0181010310	Shim.....	2
6	0181010320	Bolt Holder.....	1	40	0181010214	Spacer .....	1
7	A182011001	Blade Guard Assembly.....	1	41	411011707	*Hex Nut (1/4-20) .....	2
8	0182011804	Rear Rail .....	1	42	412011743	Washer (M6.5 x 25 x 1.6T) .....	1
9	0182010214	End Cap R2 (left rear) .....	1	43	410011714	*Screw (1/4-20 x 1 in., Hex Hd.)..	1
10	0182010213	End Cap R1 (right rear) .....	1	44	A182010101	Motor Assembly.....	1
11	0182010101-126	Saw Table .....	1	45	0182010304-129	Cabinet Panel, Right .....	1
12	0181010829	*Screw (10-24 x 3/4 in., Pan Hd.).....	3	46	411011008	*Lock Nut (8-32) .....	3
13	0182010315-127	Throat Plate .....	1	47	0181010816	*Grounding Screw (8-32 x 3/4 in.).....	1
14	0182010216-127	Align-A-Cut Insert.....	1	48	0182010701	Power Cord (14 Awg x 33 m)....	1
15	410011708	*Screw (5/16-18 x 3/4 in., Hex Hd.).....	4	49	410451703	*Screw (8-16 x 3/4 in.).....	5
16	0182010207	Rail Locking Clamp.....	4	50	0301030202	Clamp (5/16 in., ACC2.5).....	1
17	412011065	Flat Washer (M8 x 16 x 0.8T)....	4	51	0181010230	Plug Socket Box, Left .....	1
18	410171705	*Screw (10-24 x 5/16 in., Pan Hd.).....	2	52	0182010102-126	Accessory Table.....	1
19	0181010814	*Screw (10-24 x 1/2 in., Special).....	4	53	451050005	Outlet .....	1
20	0182010302-129	Cabinet Panel, Rear .....	1	54	0181010231	Plug Socket Box, Left .....	1
21	0181010303-129	Cabinet Panel, Left .....	1	55	A182010901	Rip Fence Assembly.....	1
22	0181010815	Screw (8-32 x 3/8 in., Special).....	14	56	0181010831	*Screw (8-32 x 3/8 in. Pan Hd.)..	2
23	0181010316	Dust Cover .....	1	57	410151704	*Screw (1/4-20 x 3/4 in.).....	1
24	0181010804	*Hex Nut (5/8-18) .....	1	58	0182010208	Lever, Accessory Table .....	1
25	0181010401	Blade Washer.....	2	59	0181010601	Lever Shaft.....	1
26	422010044	Blade (10 in. x 36T).....	1	60	412011063	*Flat Washer (M12 x 22 x 1T)....	3
27	0181010503	1/4 in. Spacer .....	1	61	413051004	E-Ring (ETW8).....	1
28	0181010504	1/2 in. Spacer .....	1	62	0181010309	Spring Plate .....	1
29	0181010110	Guide Holder.....	1	63	0181010211	Back-up Plate .....	1
30	410141702	*Screw (8-32 x 3/4 in., Pan Hd.)..	4	64	411072702	*Nylon Nut (1/4-20).....	1
31	918101533570	Grounding Label.....	1	65	0181010606	Shaft.....	1
32	0181010823	Screw (10-24 Pan Hd., Special)..	4	66	0181010105	Bevel Gear .....	2
33	0131010222-130	Power Cord Holder, Rear.....	2	67	414011014	Roll Pin (M4 x 30 mm).....	2
34	0181010314	Shim (0.5 mm).....	2	68	412011063	*Screw (M4 x 20 mm).....	4
				69	410171707	*Screw (10-24 x 5/8 in., Pan Hd.).....	4



**CRAFTSMAN 10 in. TABLE SAW – MODEL NO. 315.218290**

**PARTS LIST – FIGURE A – Cont'd**

Key Part No.	Part Number	Description	Qty.	Key Part No.	Part Number	Description	Qty.
70	0181010905	Needle Roller .....	2	97	0182010105-58	Bevel Locking Lever.....	1
71	0181010312	Locker Support.....	2	98	410071705	* Set Screw (1/4-20 x 3/8 in.).....	1
72	412011068	* Flat Washer (M10 x 22 x 1T) .....	1	99	0181010108-58	Cam.....	1
73	411071709	* Hex Nut (3/8-16) .....	1	100	0181010912	Spring.....	1
74	0181010829	* Screw (8-32 x 1-3/16 in., Pan Hd.) .....	1	101	A182014001	Height/Bevel Adjustment Handwheel.....	1
75	0181010607	Gear Shaft.....	1	102	0181010264	Switch Box.....	1
76	414011003	Roll Pin (M4 x 20 mm).....	1	103	452070018	Switch With Key.....	1
77	0181010502	Clutch.....	1	104	0182010219	Switch Key.....	1
78	0181010914	Spring .....	1	105	0182010211	End Cap (front left).....	1
79	0181010608	Handle Shaft .....	1	106	0182010212	End Cap (front right) .....	1
80	0181010507	Tilting Gear.....	1	107	9182015330301	Scale Label .....	1
81	410171707	* Screw (10-24 x 5/8 in., Pan Hd.) .....	4	108	0182011803	Front Rail.....	1
82	A181012501	Clamper Bracket.....	1	109	410455705	* Self-Tapping Screw (M4 x 3/4 in.) .....	4
83	0181010109	Gear Rack .....	1	110	410031710	* Carriage Bolt (5/16-18 x 1/2 in.).....	1
84	0182010301-129	Cabinet Panel, Front .....	1	111	410451015	* Screw (M5 x 18 mm).....	4
85	0182010201-129	Cabinet Panel Plate, Front .....	1	112	0182010203	Cabinet Plate, Left .....	1
86	410561004	* Screw (M4 x 12 mm Pan Hd.) .....	4	113	0182010206	Storage Bracket Holder .....	2
87	9182015330204	Warning Label .....	1	114	0134010238	Knob Ring .....	1
88	9182015330101	Name Plate.....	1	115	0121010221	Knob .....	1
89	410011714	* Screw (1/4-20 x 1 in., Hex Hd.) ..	1	116	410561002	* Screw (M4 x 16 Pan Hd.) .....	8
90	411011707	* Hex Nut (1/4-20).....	2	117	0182010205	Miter Table Holder, Right .....	2
91	410011716	* Screw (1/4-20 x 2 in., Hex Hd.).....	1	118	0182010204	Miter Table Holder, Left.....	2
92	410261004	* Screw (10-24 x 5/8 in. ....	3	119	A182010802	Miter Gauge Assembly .....	1
93	0181010222	Bevel Indicator .....	1	120	410171706	* Screw (10-24 x 1/2 in.).....	7
94	412015080	Washer (M19.5 x 30 x 1.5T) .....	1	121	0131010217-130	Power Cord Holder, Front .....	1
95	0181010913	Washer (M18.5 x 28 x 0.5T) .....	1	122	410561004	Screw (M4 x 12 mm).....	2
96	411011709	* Hex Nut (3/4-16).....	1				

\*Standard Hardware Item – May Be Purchased Locally

**NOTE: "A" – The assembly shown represents an important part of the double insulated system. To avoid the possibility of alteration or damage to the system, service should be performed by your nearest Sears Repair Center. Contact your nearest Sears Retail Store for Service Center information.**

**⚠ WARNING:** Improper repair of a double insulated product can result in damages to the double insulation system possibly causing electrical shock or electrocution. Any repairs requiring disassembly of your table saw requires safety testing to be performed by your nearest Sears Repair Center. Contact your nearest Sears Retail Store for Service Center information.



**CRAFTSMAN 10 in. TABLE SAW - MODEL NO. 315.218290**  
**FIGURE B: SLIDING MITER TABLE ASSEMBLY**

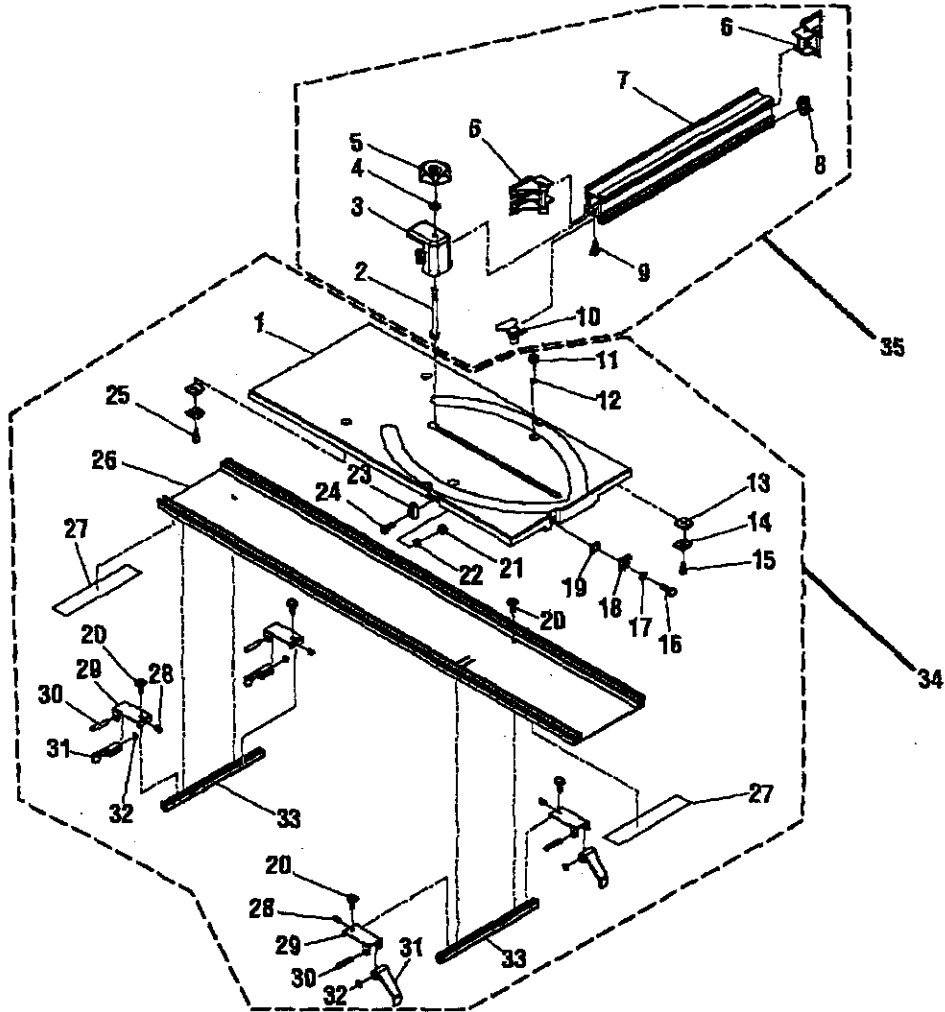

Key Part No.	Part Number	Description	Qty.	Key Part No.	Part Number	Description	Qty.
1	0182010103-126	Miter Table Top .....	1	18	0181010306	Miter Slide Lock.....	1
2	410011717	*Bolt (5/16-18 x 3-1/4 in., Hex Hd.)...	1	19	0181010305	Spring Plate .....	1
3	0181010210	Fence Holder .....	1	20	410171702	*Screw (1/4-28 x 10 mm., Pan Hd.) .....	8
4	412011051	Flat Washer (M8 x 16 x 1.5T).....	1	21	411072704	*Nylon Nut (5/32 in.).....	2
5	0181010209	Adjusting Clamp Knob .....	1	22	412012006	*Flat Washer (M4 x 9 x 0.8T).....	2
6	0134010227	Saw Gauge .....	2	23	0181010501	Quick Stop.....	2
7	0182011801	Miter Fence .....	1	24	0181011811	Eccentric Screw .....	2
8	0181010208-58	Miter Indicator .....	2	25	0181011810	Eccentric Screw .....	3
9	410451702	*Screw (3/16 in.).....	2	26	0182011802	Miter Base .....	1
10	0134010244	Locator Pin .....	1	27	0181011802	Guide Plate .....	2
11	411071708	*Nylon Nut (3/16 in.).....	4	28	410079012	*Set Screw (3/16-24 x 1/4 in.).....	4
12	412041703	*Lock Washer (3/16 in.) .....	4	29	0181010308	Holder Plate.....	4
13	0181010203	Slide (upper) .....	4	30	414011026	Roll Pin (M6.35 x 31.75 mm) .....	4
14	0181010204	Slide (lower) .....	4	31	0181010205	Miter Locking Clamp .....	4
15	0181010802	Non-Eccentric Screw .....	1	32	0181011301	O-Ring .....	4
16	410171708	*Screw (3/16-24 x 1/2 in., Pan Hd.) .....	1	33	0181011803	Guide Bar .....	2
17	412011062	*Flat Washer (M5.5 x 12.5 x 1.5T)...	1	34	A182012001	Accessory Table Assembly.....	1
				35	A182010801	Miter Fence Assembly.....	

\* Standard Hardware Item - May Be Purchased Locally



**CRAFTSMAN 10 in. TABLE SAW – MODEL NO. 315.218290**  
**FIGURE C: RIP FENCE ASSEMBLY**

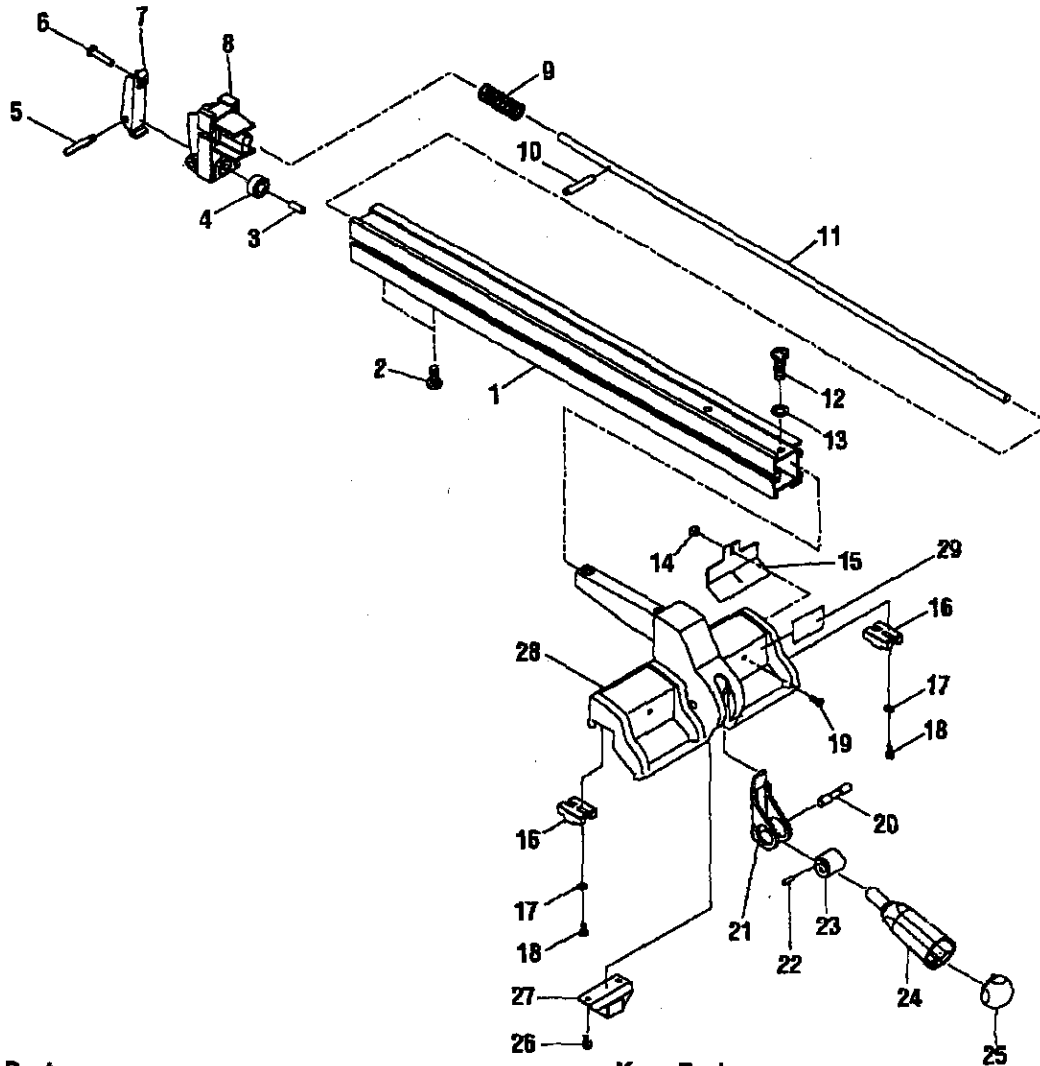

Key Part No.	Part Number	Description	Qty.	Key Part No.	Part Number	Description	Qty.
1	0182011805	Rip Fence .....	1	16	0181010219	Slide.....	2
2	0181010805	* Screw (12-14 x 1/2 in., Pan Hd.) .....	2	17	412011006	Washer (M4 x 9 x 0.8T).....	2
3	414050006	Dowel Pin (1/4 in. x 18 mm).....	1	18	410171704	* Screw (8-32 x 12.7 mm, Pan Hd.) .....	2
4	0181010218	Fence Roller .....	1	19	410131719	* Screw (8-32 x 1/2 in.) .....	1
5	414011024	Roller Pin (M6.35 x 38.1 mm) ..	1	20	0181010904	Pin .....	1
6	410139719	* Screw (10-24 x 1 in., Pan Hd.).....	1	21	0182010318	Clamper .....	1
7	0181010319	Clamp, Rear .....	1	22	0181011303	Rubber Plug (M4 x 7.6 mm).....	1
8	0181010220	Roller Holder.....	1	23	0181010506	Eccentric Roller .....	1
9	0181010907	Compression Spring .....	1	24	0181010227	Handle With Cap .....	1
10	414011030	Roller Pin (M3.3 x 19.05 mm) .....	1	25	0181010226	End Cap for Handle Grip .....	1
11	0181010906	Rod .....	1	26	0181010806	* Screw (8-32 x 3/8 in.) .....	2
12	410491703	* Screw (1/4-20 x 5/8 in.) .....	2	27	0181010217	Plate .....	1
13	412011064	Washer (M7 x 16 x 1.5T).....	2	28	0181010115-126	Front Block.....	1
14	411011711	* Hex Nut (8-32 x 8.5 mm.) .....	1	29	9182015335001	Label.....	1
15	0181010243	Scale Indicator.....	1				

\* Standard Hardware Item - May Be Purchased Locally



**CRAFTSMAN 10 in. TABLE SAW – MODEL NO. 315.218290**  
**FIGURE D: HEIGHT/BEVEL ADJUSTMENT HANDWHEEL**

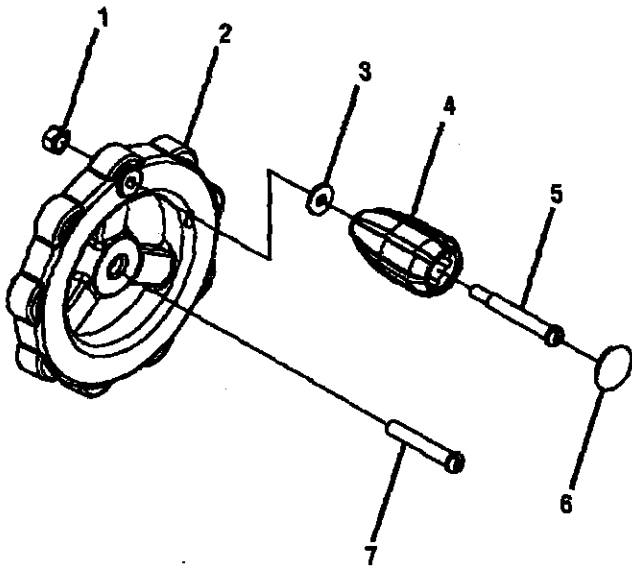

Key Part No.	Part Number	Description	Qty.
1	411072702	*Lock Nut (1/4-20) .....	1
2	0182010202-130	Height/Bevel Adjustment Handwheel .....	1
3	412012041	*Flat Washer (M6.5 x 13 x 1.5T) ...	1
4	0121010223	Handwheel Grip .....	1
5	0101140203	Screw .....	1
6	0121010224	End Cap .....	1
7	0181010826	Screw (1/4-20).....	1
	A182014001	Blade Adjustment Handwheel Assembly (Incl. 1-7).....	1
	A121015201	Handwheel Handle Assembly (Incl. 1,3-6) .....	1

\*Standard Hardware Item – May Be Purchased Locally

**FIGURE E: REPLACEMENT PARTS**

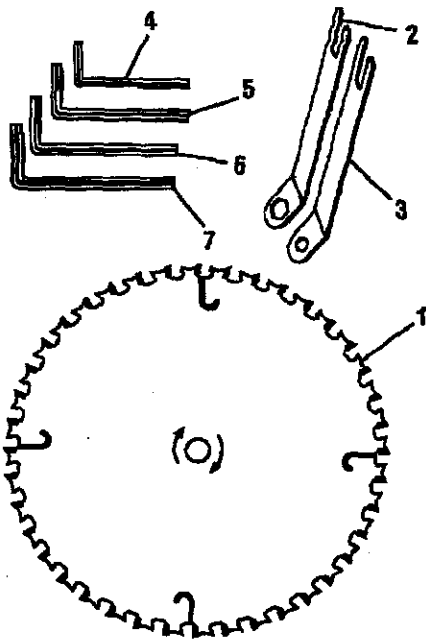

Key Part No.	Part Number	Description	Qty.
1	422010044	Saw Blade (10 in. x 36T).....	1
2	0131010319	Large Wrench .....	1
3	0131010318	Small Wrench .....	1
4	0181010915	3/32 in. Hex Key .....	1
5	0181010916	1/8 in. Hex Key .....	1
6	0181010918	3/16 in. Hex Key .....	1
7	0181010917	5/32 in. Hex Key.....	1

\*Standard Hardware Item – May Be Purchased Locally

**CRAFTSMAN 10 in. TABLE SAW – MODEL NO. 315.218290**  
**FIGURE F: MITER GAUGE ASSEMBLY**

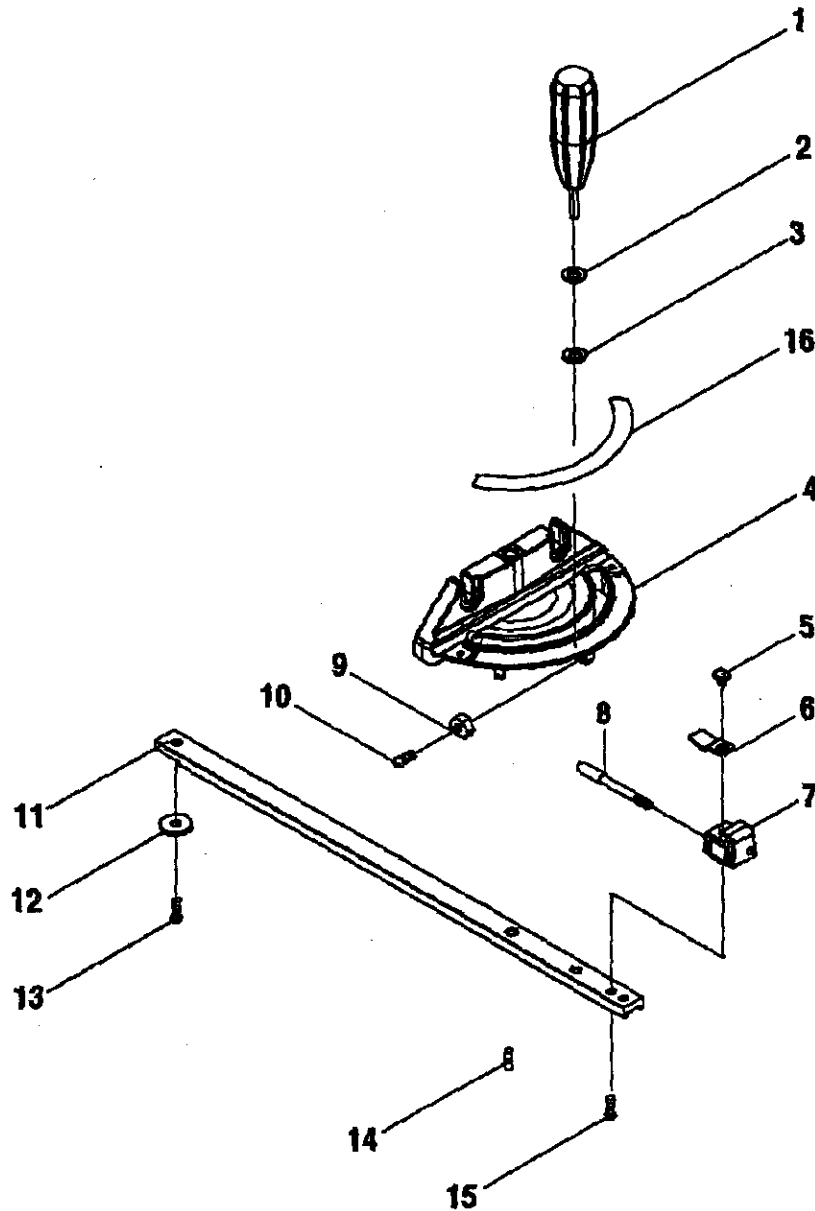

Key Part No.	Part Number	Description	Qty.	Key Part No.	Part Number	Description	Qty.
1	A182015201	Miter Gauge Handle .....	1	9	411012704	* Hex Nut (3/16-24) .....	3
2	412012705	* Flat Washer (1/4 x 16 x 1.5T).....	1	10	410132734	* Screw (3/16-24 x 21.7 mm, Pan Hd.)..	3
3	412080702	* Nylon Washer (1/4 x 16 x 2T) .....	1	11	0182011806	Miter Gauge Bar .....	1
4	0182010104-126	Miter Gauge .....	1	12	0131010928	Miter Gauge Pulley .....	1
5	0182010803	* Screw (M4 x 8 mm).....	1	13	410102014	Screw (M6 x 8 mm, Flat Hd.)... 1	1
6	0182010210	Scale Indicator.....	1	14	0101010917	Eccentric Pin (1/4 in.).....	1
7	0121010204	Indicator Bracket.....	1	15	410561004	* Screw (M4 x 12 mm).....	2
8	0101010918	Pin .....	1	16	9182015330302	Miter Gauge Scale Label .....	1

\*Standard Hardware Item – May Be Purchased Locally

**CRAFTSMAN 10 in. TABLE SAW – MODEL NO. 315.218290**  
**FIGURE G: ROUTER ACCESSORIES**

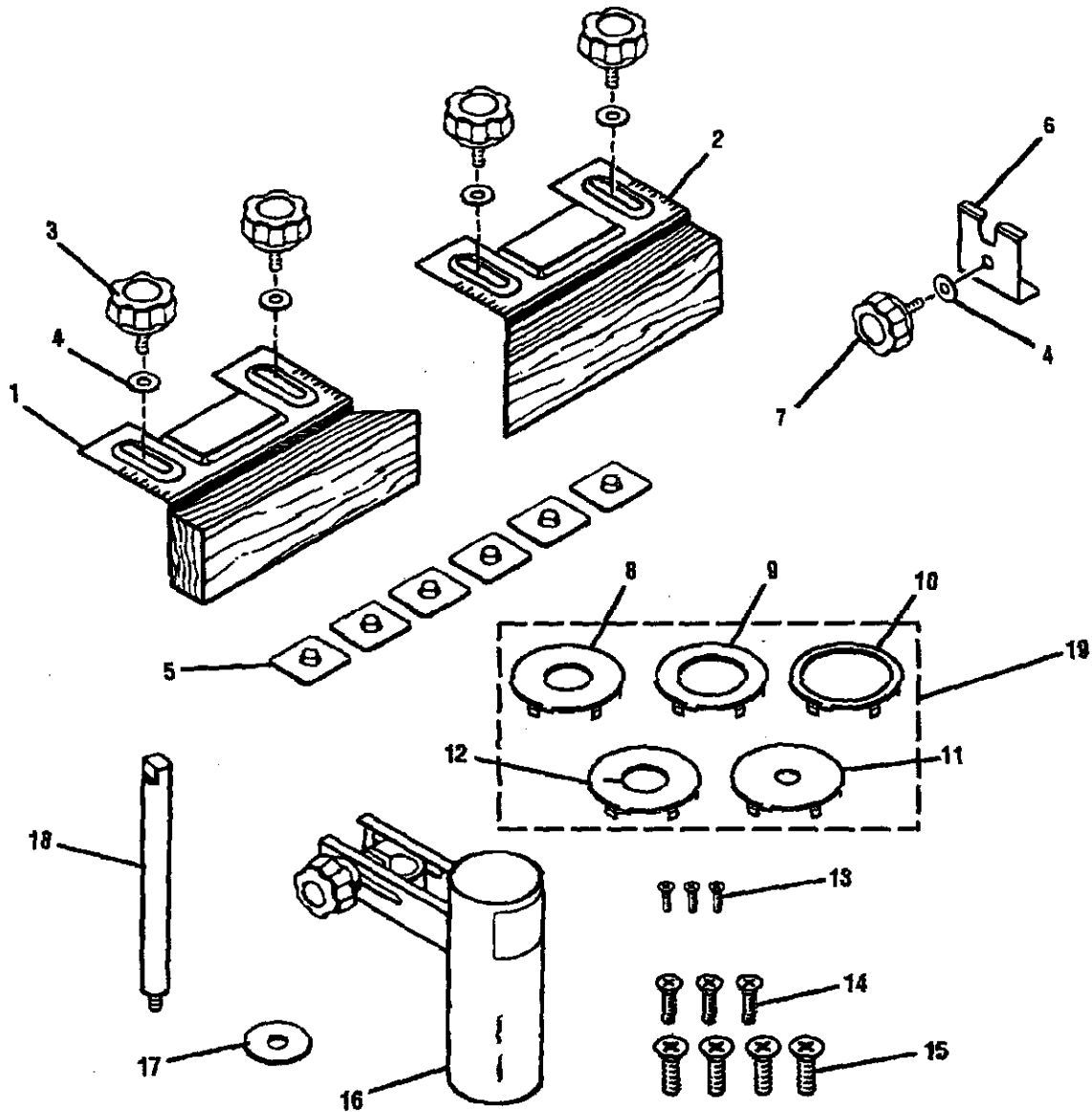

Key Part No.	Number	Description	Qty.	Key Part No.	Number	Description	Qty.
1	A181014605	Guide Fence w/Guide Block (left) and Screws	1	10	0181010253-127	Throat Plate (2 in.)	1
2	A181014606	Guide Fence w/Guide Block (right) and Screws	1	11	0181010250-127	Throat Plate (1/2 in.)	1
3	0181010257	Knob Bolt (1/2 in.)	4	12	0181010254-127	Throat Plate (1-1/8 in.)	1
4	412011071	*Washer (M19 x 8.3 x 1.5T)	4	13	410101714	*Screw (10-32 x 3/4 in.)	3
5	0181010347	T-Nut (5/16-18)	6	14	410101707	*Screw (5/16-18 x 3/4 in.)	3
6	0181010349	Table Clamping Bracket	1	15	410101013	Screw (M8 x 24 mm)	4
7	0181010258	Knob (5/16-18 x 3/4 in.)	1	16	A181014601	Guard/Dust Cover Assembly	1
8	0181010251-127	Throat Plate (1 in.)	1	17	412011073	Washer	1
9	0181010252-127	Throat Plate (1-1/2 in.)	1	18	0181010819	Post (M19 x 163 mm)	1
				19	A181011004-1	Throat Plate Assembly (Incl. 8-12)	1
				20	A182017001	Router Mounting Kit (Incl. 1-20)	1

\* Standard Hardware Item – May Be Purchased Locally



CRAFTSMAN 10 in. TABLE SAW - MODEL NO. 315.218290

The model number will be found on a plate attached to the side panel of the cabinet. Always mention the model number in all correspondence regarding your TABLE SAW or when ordering repair parts.

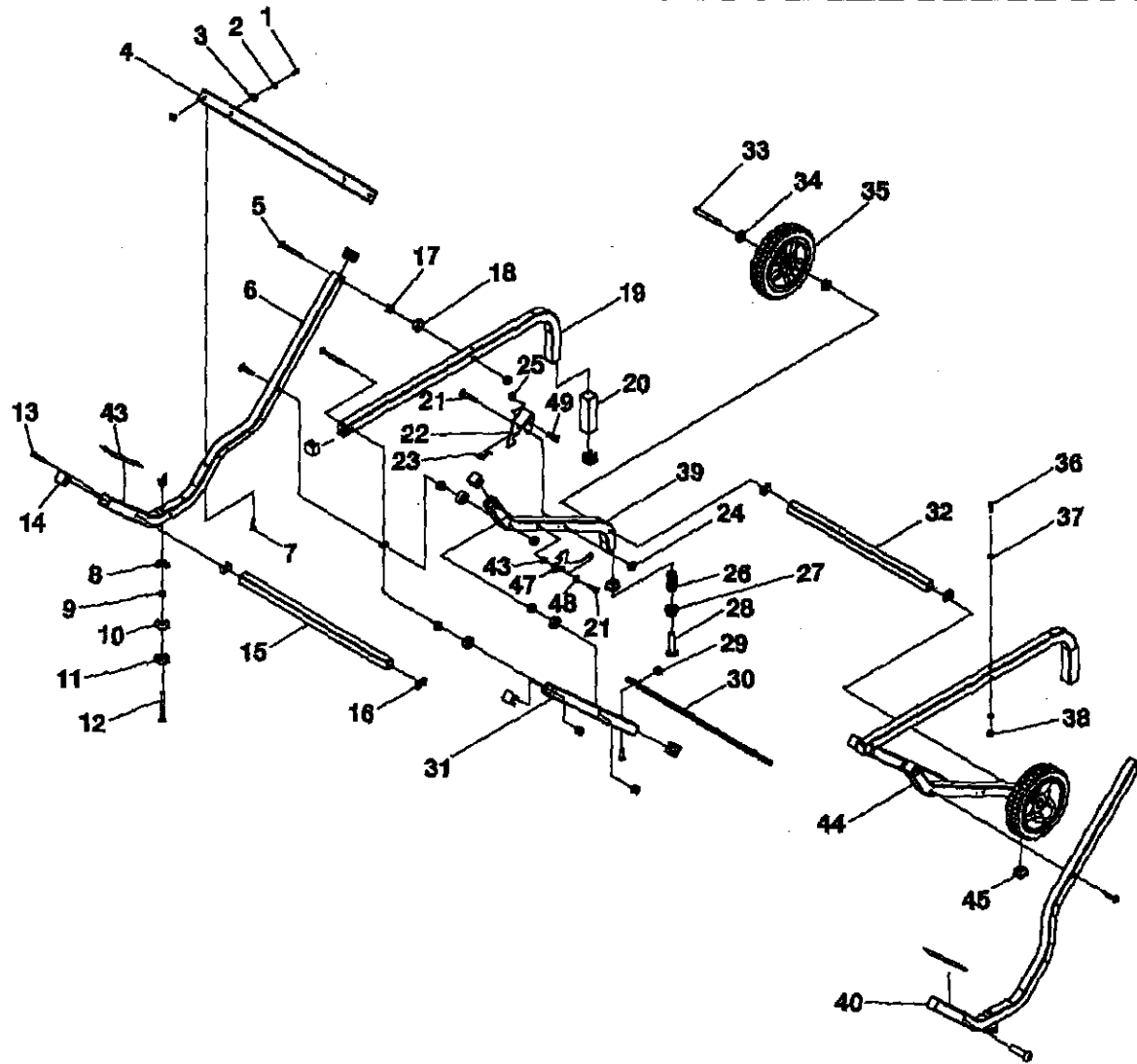

56

FIGURE G

**CRAFTSMAN 10 in. TABLE SAW – MODEL NO. 315.218290**

The model number will be found on a plate attached to the side panel of the cabinet. Always mention the model number in all correspondence regarding your **TABLE SAW** or when ordering repair parts.

**PARTS LIST FOR FIGURE G**

57

Key Part No.	Part Number	Description	Qty.	Key Part No.	Part Number	Description	Qty.
1	410171706	* Screw (10-24 x 1/2")	2	27	0131010232	Adjusting Handle	2
2	412011020	* Washer (M5.2 x 14 x 1T)	2	28	410031714	* Carriage Bolt (5/8-11 x 88.9 mm)	2
3	0161010201	Feet Plug (M34 x 8.4 x 14)	2	29	411071705	* Nylon Nut (5/16 in.)	4
4	0182010317-126	Upper Support Plate	1	30	0182010316-126	Down Support Plate	1
5	410031717	* Carriage Bolt (5/16 x 80 mm)	10	31	0182010310-126	Leg Support (30 mm)	2
6	0182010307-126	Leg Frame, Right (30 mm)	1	32	0182010312-126	Connecting Tube, Rear (30 mm)	1
7	410031718	* Carriage Bolt (5/16 x 40 mm)	4	33	0182010801	Wheel Screw (5/16 in.)	2
8	411171703	* Wing Nut (5/16 in.)	4	34	412011088	* Washer (M13 x 32 x 1.5T)	4
9	411061704	* Wing Nut (3/8 in.)	2	35	0182010217-130	Wheel, 8 in.	2
10	0182010305	Plug	2	36	410151714	* Socket Hex Head Screw (1/4 x 40 mm)	4
11	0182011301	Leg Frame Foot Plug, Right	2	37	412011003	* Washer (M6.5 x 16 x 2T)	8
12	0182010802	Foot Plug Screw (3/8 x 80 mm)	2	38	0000110812	Nylon Nut (1/4-20)	4
13	410491704	* Screw, Hex Hd. (5/16-18 x 57 mm)	2	39	0182010308-126	Center Leg Frame	2
14	0182010215	End Cap, Leg Frame	14	40	0182010306-126	Leg Frame, Left	1
15	0182010311-126	Front Connecting Tube	1	41	0000120915	* Lock Washer (5/16 in.)	2
16	0182010313	Tooth Plate	4	42	412011067	* Washer (M8 x 18 x 1.5T)	2
17	411071705	* Nylon Nut (5/16 in.)	20	43	9182015335701	Leg Stand Label	2
18	0182010209	Connecting Ring	8	44	0182010320-126	Short Leg, Right	1
19	0182010309-82	Leg Frame Handle	2	45	0182010319	Square Nut	2
20	0182011302	Grip	2	46	412011116	Washer (D8.2 x 23 x 3T)	1
21	410151019	* Hex Socket Screw (M8 x 50 mm)	2	47	0182010321	Latch	1
22	0182010314	Release Lever	1	48	412011080	Washer (D8.26 x 21.9 x 1.5T)	1
23	0182010901	Release Lever Spring	1	49	410151021	Hex Socket Screw (M6 x 15 mm)	1
24	411071006	* Nylon Nut (M8)	1	50	411071001	Nylon Nut	1
25	411071001	Nylon Nut	1		A182011301	Leg Stand Assembly (Incl. 1-49)	1
26	0131010918	Adjusting Spring	2		983000693	Operator's Manual	

\* Standard Hardware Item – May Be Purchased Locally

Get fixed at your home or ours

### Your Home

For repair—in your home—of all major brand appliances, lawn and garden equipment, or heating and cooling systems, **no matter who made it, no matter who sold it!**

For the replacement parts, accessories and owner's manuals that you need to do-it-yourself.

For Sears professional installation of home appliances and items like garage door openers and water heaters.

**1-800-4-MY-HOME® (1-800-469-4663)**

Call anytime, day or night (U.S.A. and Canada)

[www.sears.com](http://www.sears.com)    [www.sears.ca](http://www.sears.ca)

---

### Our Home

For repair of carry-in items like vacuums, lawn equipment, and electronics, call or go on-line for the location of your nearest **Sears Parts & Repair Center.**

**1-800-488-1222**

Call anytime, day or night (U.S.A. only)

[www.sears.com](http://www.sears.com)

---

To purchase a protection agreement (U.S.A.) or maintenance agreement (Canada) on a product serviced by Sears:

**1-800-827-6655 (U.S.A.)**

**1-800-361-6665 (Canada)**

---

Para pedir servicio de reparación a domicilio, y para ordenar piezas:

**1-888-SU-HOGAR<sup>SM</sup>**

(1-888-784-6427)

Au Canada pour service en français:

**1-800-LE-FOYER<sup>MC</sup>**

(1-800-533-6937)

[www.sears.ca](http://www.sears.ca)

**Sears**