



The Signature of Quality®

INSTALLATION & OPERATIONS INSTRUCTIONS
*Hot Counter Displays
(Curved & Straight)
(Service & Self-Serve)*



KEEP THIS MANUAL FOR FUTURE REFERENCE

Engineering and technical data are subject to change without notice.

FEDERAL INDUSTRIES
Toll Free 1(800) 356-4206

215 Federal Avenue
WI Phone (608) 424-3331

Belleville, WI 53508
Fax: (608) 424-3234

CONTENTS

INTRODUCTION	3
WARNING LABELS & SAFETY INSTRUCTIONS	4
PRE-INSTALLATION PROCEDURES	5
Inspection For Shipping Damage.....	5
GENERAL ELECTRICAL & GROUNDING	5
INSTALLATION INSTRUCTIONS	5
General Display Case Location.....	5
Removing Case From Shipping Skid	5-6
Cleaning.....	6
Cabinet Preparation	6
Cord Options	7
Case Line Up Installation.....	7
Top Joining Bracket	8
Bottom Pedestal Joining.....	9
END PANEL INSTALLATION	10
SHELVING INSTALLATION & REMOVAL	11
Shelf Brackets & Shelves	11
Shelves and shelf light quantity.....	11
DOOR REMOVAL INSTRUCTIONS	12
OPERATING INSTRUCTIONS	13
Controls	13
Shelves.....	13
Rear Package Shelf.....	13
Initial Start Up.....	14
Placing Product Into Case	14
Unit Shut Down.....	15
MAINTENANCE	15
Water Pan Filling.....	16
Light Bulb Replacement.....	16
CLEANING INSTRUCTIONS	17
Acrylic Door & Top Cleaning.....	17
Daily Cleaning.....	17
Weekly Cleaning	18
Interior Cleaning.....	18
Exterior Cleaning	18
Water pan Cleaning	19
SERVICE INFORMATION	19
Pre-Service Checklist	20
Special Service Situations	20
SALE & DISPOSAL	21
Owner Responsibility	21
ELECTRICAL DATA	21
WIRING DIAGRAMS	22
PARTS	23

INTRODUCTION

Thank you for purchasing a Federal Industries display case. This manual contains important instructions for installing and servicing the Curved Glass Service and Self Serve. A repair parts list and wiring diagram are also included in the manual. Read all of these documents carefully before installing or servicing your case.



NOTICE

Read this manual before installing your case. Keep this manual and refer to it before doing any service on the equipment. Failure to do so could result in personal injury or damage to the case.



NOTICE

Installation and service of the electrical components in the case must be performed by a licensed electrician.

The portions of this manual covering components contain technical instructions intended only for persons qualified to perform electrical work.



DANGER

Improper or faulty hookup of electrical components in the case can result in severe injury or death.

All electrical wiring hookups must be done in accordance with all applicable local, regional, or national standards.

SERIAL NUMBER

Record the model and serial numbers of the case for easy reference. Always refer to both model and serial numbers in your correspondence regarding the case.

Case Model _____ Serial Number _____
Condensing Unit Model _____ Serial Number _____

This manual cannot cover every installation, use, or service situation. If you need additional information, call or write us:

CUSTOMER SERVICE DEPARTMENT
Federal Industries
215 Federal AVE
Belleville, WI 53508
Toll Free (800) 356-4206 / WI Phone (608) 424-3331

WARNING LABELS & SAFETY INSTRUCTIONS



This is the safety-alert symbol. When you see this symbol on your case or in the manual, be alert to the potential for personal injury or damage to your equipment.

Be sure you understand all safety messages and always follow recommended precautions and safe operating procedures.



NOTICE TO EMPLOYERS

You must make sure that everyone who installs, uses, or services your case is thoroughly familiar with all safety information and procedures.

Important safety information is presented in this section and throughout the manual. The following signal words are used in the warning and safety messages:

DANGER: Severe injury or death will occur if you ignore the message.

WARNING: Severe injury or death can occur if you ignore the message.

CAUTION: Minor injury or damage to your case can occur if you ignore the message.

NOTICE: This is important installation, operation, or service information. If you ignore the message, you may damage your case.

The warning and safety labels shown throughout this manual are placed on your Federal Industries case at the factory. Follow all warning label instructions. If any warning or safety labels become lost or damaged, call our customer service department at 1(800) 356-4206 for replacements.

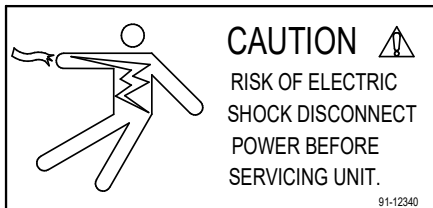

This label is located on the back of the display case.

CAUTION: HOT

This label is located on shelves and floor of display case.

PRE-INSTALLATION PROCEDURES

Inspection for Shipping Damage

You are responsible for filing all freight claims with the delivering truck line. Inspect all cartons and crates for damage as soon as they arrive. If damage is noted to shipping crates, cartons, or if a shortage is found, note this on the bill of lading (all copies) prior to signing.

If damage is discovered when the case is uncrated, immediately call the delivering truck line and follow up the call with a written report indicating concealed damage to your shipment. Ask for an immediate inspection of your concealed damage item. Crating material must be retained to show the inspector from the truck line.

GENERAL ELECTRICAL & GROUNDING



DANGER: Improper or faulty hookup of electrical components in the display case can result in severe injury or death.

-All models are supplied with a power cord that is properly sized to the amperage requirements of the case. See the electrical data plate located on the rear left interior of the case for the proper circuit size for each case.

- The cord is factory installed protruding from the bottom rear corner of the case (see the “Cord Options” section of this manual for alternate location.). If factory installed cord must be relocated for desired application the electrical work must be performed by a licensed electrician.

-A separate circuit for each display case is recommended to prevent other appliances on the same circuit from overloading the circuit and causing malfunction.

-All electrical wiring hookups must be done in accordance with all applicable local, regional, or national electrical standards

INSTALLATION INSTRUCTIONS

General Display Case Location

The case should be located where it is not subjected to the direct rays of the sun, heating ducts, grills, radiator, or ceiling fans, nor should it be located near open doors or main door entrances. Also, avoid locations where there are excessive air movement or air disturbances. Allow at least 6” of clearance from end of case to any walls or partitions.

Removing Case From Shipping Skid & General Installation



CAUTION: Do not push against the top glass, front glass, end glass, doors or door frames when removing the case from the skid or moving the case. Case damage or glass breakage could result.

1. Remove crate top and sides and note missing or damaged items as explained in the pre-installation procedures outlined above.
2. Move the case as near as possible to the final location and before removing it from the shipping skid.
3. Remove the (4) brackets that secure the case to the shipping skid. (brackets may either be screwed to side of case or hooked into bottom of case frame)
4. Prepare cabinet according to instructions in this section that pertain to your model.
5. Lift the case off of skid and into required position. Only lift the case from the frame channels located on each end of the case
6. Fasten each case to the cabinet top. From under the counter install the supplied (2) #12 self drilling screws through the holes drilled shown in cabinet preparation section.
7. Rout electrical cord according to instructions in this section that pertain to your model.
8. Case must be sealed to the counter using a NSF listed sealant
9. Install end panels.

Cleaning

For initial setup, clean the case as outlined in the “Weekly Cleaning” section of this manual.

Cabinet Preparation

The CH models require (2) 1/2”dia. case fastening holes to be drilled through the counter top surface to attach case to counter. Use the diagram below for hole placement location.

IMPORTANT: When placing cases in a line up the number of end panels used will be different. The cut out and hole placement dimension will need to be adjusted for each particular line up circumstance. See LINE UPS INTALLATION section of this manual.

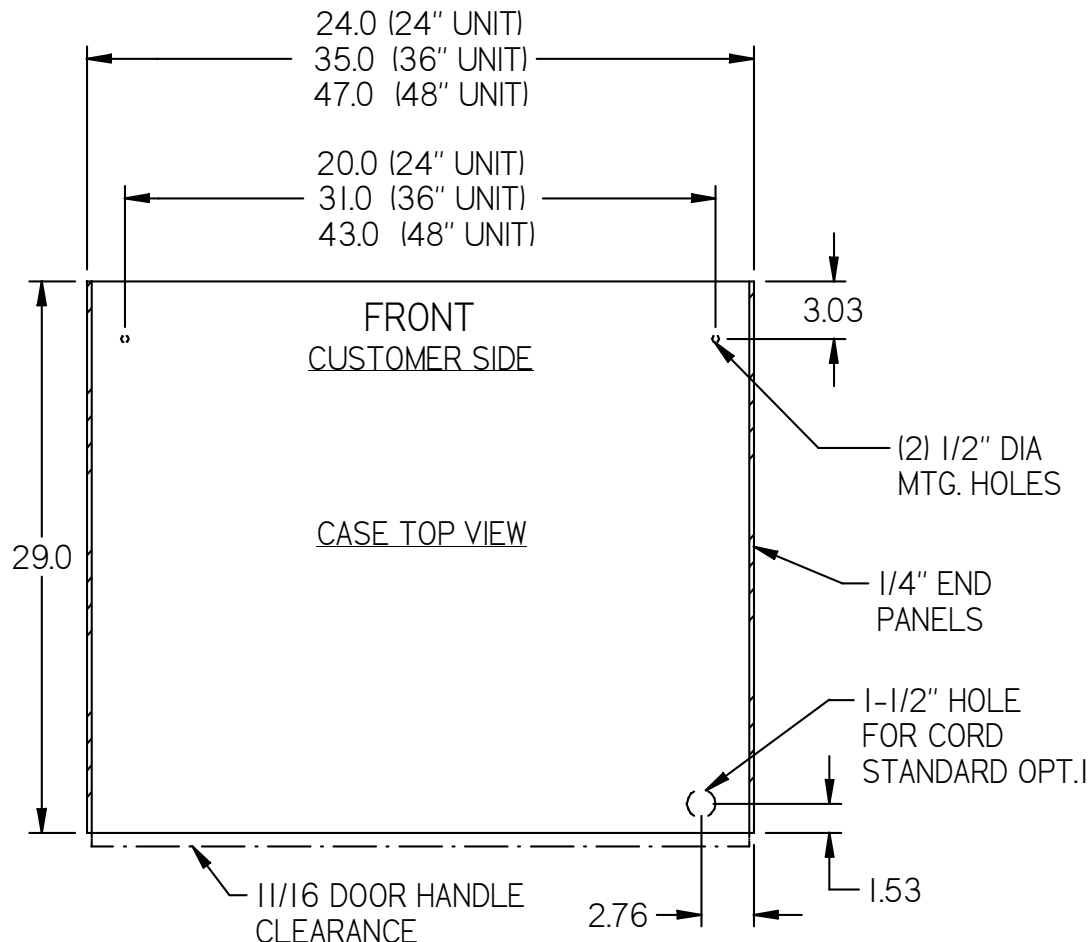

Countertop and floor mounted units must be sealed to the floor or counter using a NSF listed sealant. This is to prevent liquid spillage on the adjacent surfaces of the floor or counter top from passing under inaccessible portions of the equipment and allow for proper sanitary operation. The sealed surfaces should be cleaned of any dirt, debris or oil and allowed to dry before sealant application.

CORD OPTIONS

Depending on how the case was ordered the power cord may shipped from the factory with the cord either protruding out the bottom rear corner or out the back rear corner. In either case the cord can be moved to desired location as described.

CORD OPTION1: An electrical cord connection hole is provided in the bottom rear corner of the case. This allows the cord to protrude out the bottom of the case and down through the cabinet top into the cabinet. A 1-1/2"dia. hole must be drilled through the counter for the power cord clearance. See diagram above for hole placement location.

CORD OPTION 2: An electrical cord connection hole is provided in the rear control panel next to the case's controls. A 1-1/2"dia hole through the counter is not required for this option.

NOTE: Only a licensed electrician must perform the electrical work required to move the cord to this optional position.



DANGER: Electric shock hazard. Do not operate unit with panels removed.

1. Remove the (8) screws holding the rear frame panel located under the door track. Remove the 7/8" hole plug from either the bottom hole or the rear hole.
2. Disconnect the power cord connections and move the cord and cord strain relief from its present location and move it to the desired location and reconnect the power cord. Plug open hole in frame channel with the 7/8" hole plug removed previously.
3. Reinstall the rear frame panel.

Case Line Up Installation

Follow the "Case Installation" procedures in this manual for each display case that is going to be adjoined in a lined up. Additional cases must be place directly next to the adjoining end of the first case

IMPORTANT: BEFORE CUTTING COUNTER TOP:

When placing cases in a line up the number of end panels used will be different. The cut out and hole placement dimensions will need to be adjusted for each particular line up circumstance as listed below.

- REFRIGERATED TO REFRIGERATED: (1) 3/4" end panel attached to one of the cases. It does not matter which case.
- REFRIGERATED TO DRY: (1) 3/4" end panel attached to the refrigerated case.
- REFRIGERATED TO HOT: (1) 1-1/2" end panel attached to the refrigerated case.
- DRY TO HOT: (1) 1-1/2" end panel attached to the refrigerated case.

Note: The end panel screws and plastic spacers are not used on the case that does not get an end panel when being butted up to a case with an end panel. Remove them from case and discard.

Once the cases are placed together with proper end panel(s). They will need to be pushed together as close as possible keeping the front of the cases in alignment. Once the adjoining case is in proper position complete all of the procedures outlined in the "Case Installation" section in this manual before installing the joining kit as outlined below.

Top Joining Bracket

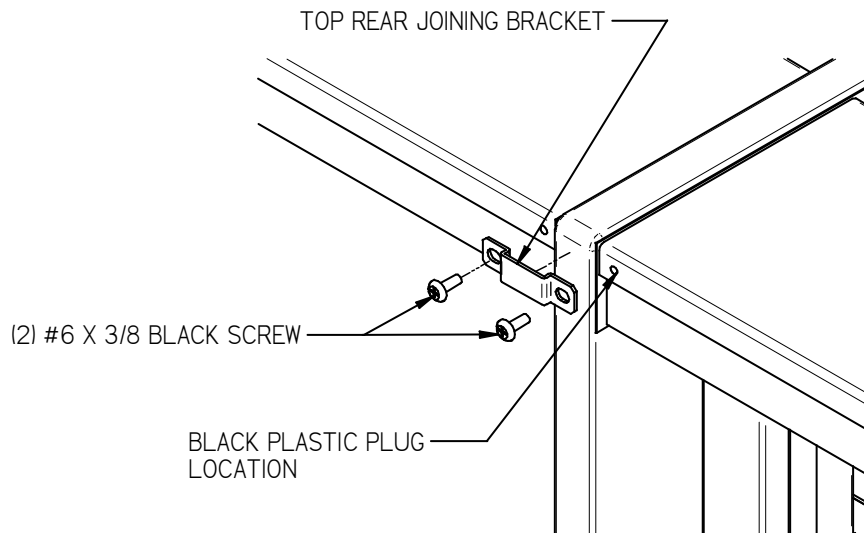

All cases joined together should have a top joining bracket installed to keep the top of the case tight together. There are different brackets included with each case to cover most joining combination needs. If no holes are provided, drill a 1/8" dia x 1/2" deep hole in location needed for bracket attachment.

1. Remove the black plug from the hole located on the upper rear corner of case.
2. Find the correct bracket shipped with case and place it over the end panel(s).
3. Hold the two cases together as much as possible to eliminate gap and fasten with screw.

Bottom Pedestal Joining

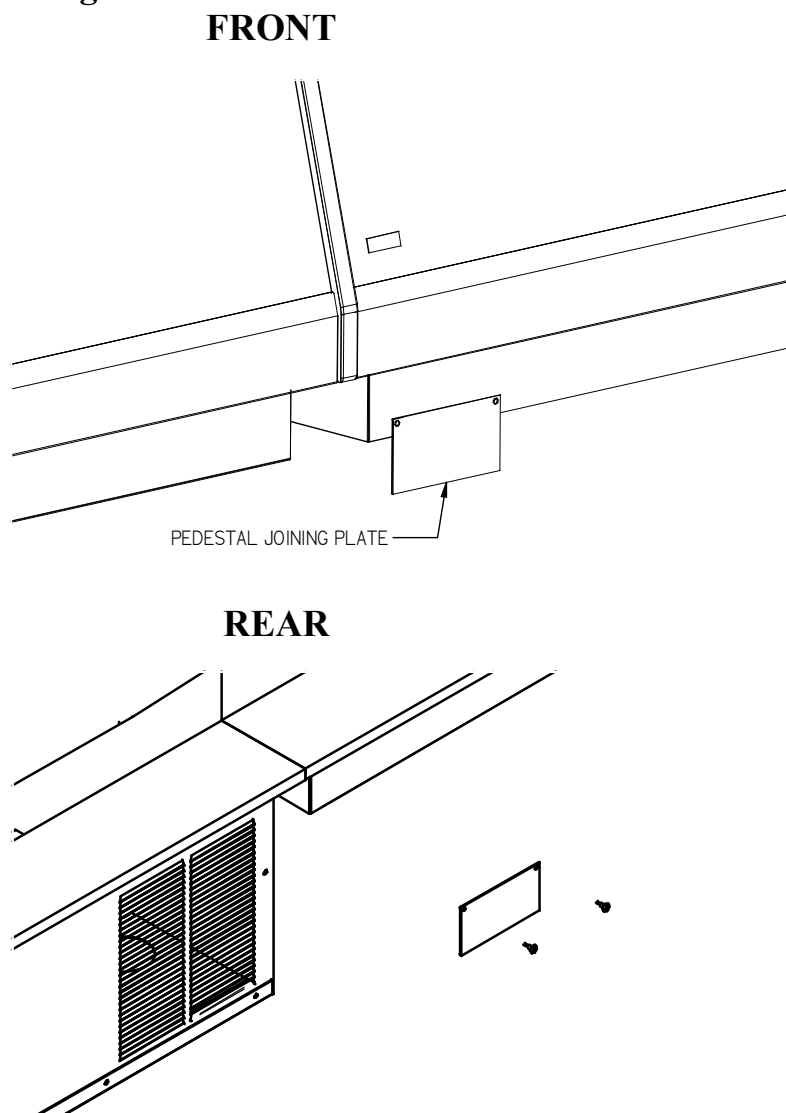

The CRR model cases and cases with optional pedestal have a 2-3/4" pedestal that sets on top the counter. When these cases are joined To either a Hot or Dry case with an optional pedestal there is a gap between the pedestals. Two joining plates are provided for these models.

The front plate is attached with self adhesive tape as follows:

1. Clean the front corner area on pedestal with rubbing alcohol.
2. Remove adhesive backing strips from pedestal joining plate.
3. Center plate over opening and press firmly into place.

The rear plate must be attached with provided screws as follows: (Screw removal will be required to access condenser compartment so do not use adhesive backing.)

1. Center plate at top of condenser compartments directly below cutting boards.
2. Mark location of (2) screw holes in cover plate on to each condenser panel.
3. Attach cover plate with (2) self drilling screws.

END PANEL INSTALLATION INSTRUCTION

CURVED GLASS MODELS ONLY

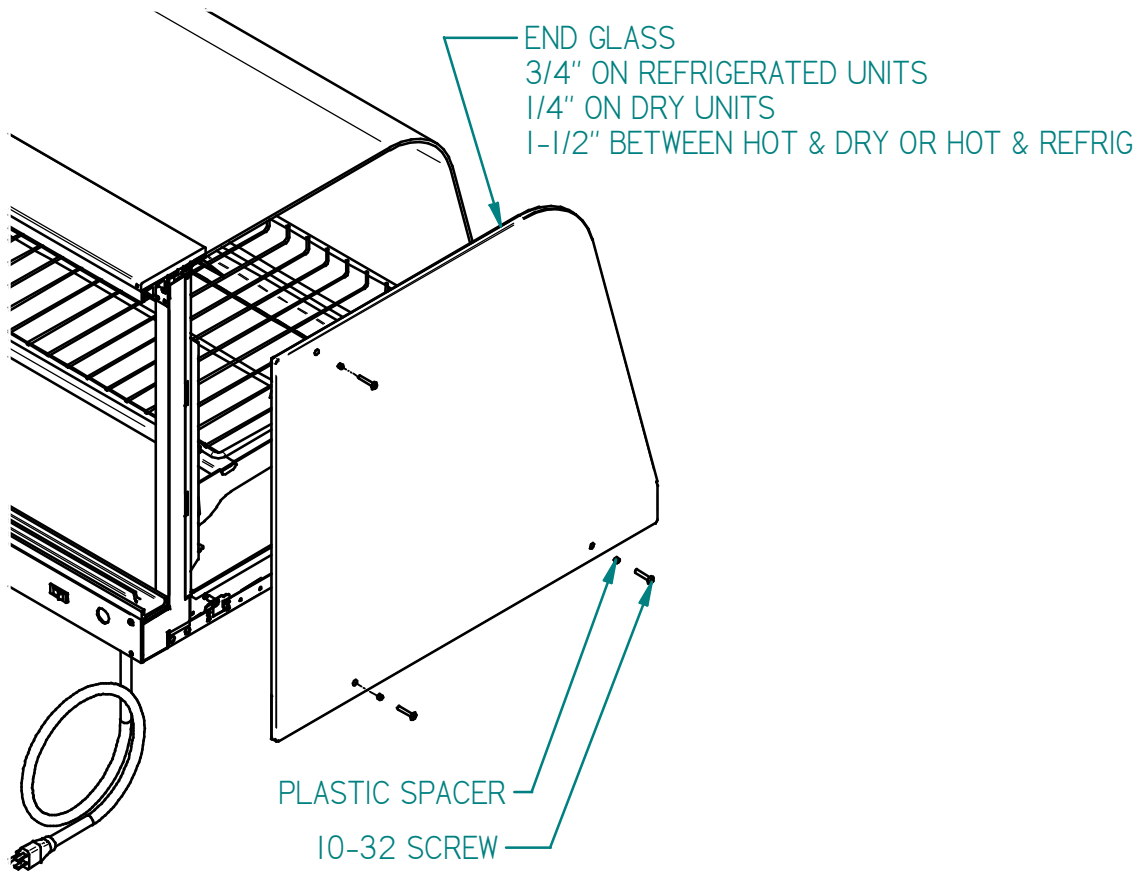

Curved Glass end panels are ordinarily shipped loose from the factory and need to be installed once the case fastened to the counter. When placing cases in a line up the number of end panels and end panel type will be different for each line up circumstance. See Case Line Up Installation section of this manual.

1. Place end panel on to the side of case and align holes.
2. Place a plastic spacer on to a screw and install the screw through the hole on end panel and into the case. Do not tighten screws until all (3) screws are started and then snug screws up, but do not over tighten or glass breakage may occur.
3. Repeat for all ends that require an end panel.

SHELVING INSTALLATION & REMOVAL

Shelf Brackets and Shelves

1. Turn the light switch and heat switch to the off position. Remove rear doors as described in the “Rear Door Removal” section of this manual to allow access to interior of case.
2. Insert a longer bottom shelf bracket in the desired shelf standard slot on one side of case (bumper side towards end glass). Follow the instructions in the illustration below. Place the additional longer bottom shelf bracket in the same shelf standard slot on the opposite end of case. Repeat for shorter top shelf tier.

NOTE: For best case operation the top hook of the top shelf bracket should be placed in the second slot from the top of the shelf standard and the top hook of the bottom shelf bracket should be placed in the fourth slot from the bottom of the shelf standard.

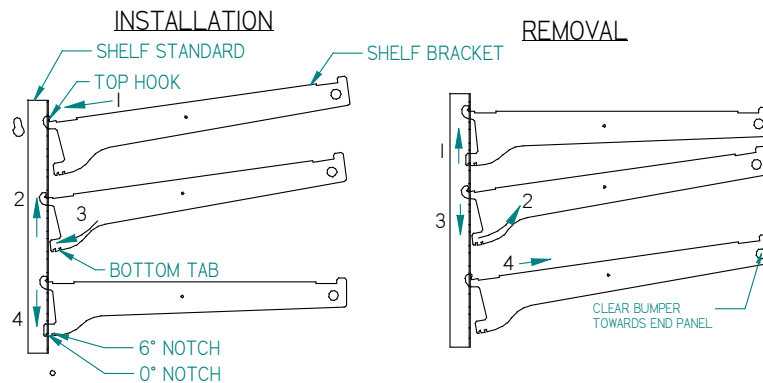

1. Place shelf bracket top hook into desired shelf standard slot.
 2. Lift shelf bracket top hook to allow shelf bracket bottom tab to clear shelf standard slot.
 3. Swing shelf bracket bottom tab into shelf standard slot.
 4. Place the desired shelf bracket notch of 0, 6, or 12 degrees onto bottom of shelf standard slot.
1. Lift shelf bracket up to allow shelf bracket notch to clear the bottom of shelf standard slot.
 2. Swing shelf bracket bottom tab out of shelf standard slot.
 3. Drop shelf bracket down to allow shelf bracket top hook to clear top of shelf standard slot.
 4. remove shelf bracket top from shelf standard slot.

3. Hang one end of shelf on the shelf bracket and then the other end of shelf on the bracket on the opposite end. The notch on the front of each side of the shelf must hook on to the tab on the front of each shelf bracket. Repeat for additional shelf tiers. **NOTE:** The shelf must be slightly tilted to get through the rear door opening. It may be easier to get both shelves into case and setting on floor before hooking them to the shelf brackets.

IMPORTANT: On double shelf models there is a specific top and bottom shelf and each shelf is labeled next to the shelf cord. For proper operation the top shelf must be on the top and the bottom shelf on the bottom.

4. Plug in each shelf in by aligning the male pins on the appropriate shelf light cord plugs with the female light sockets and push together. **NOTE:** Do not roll plug during insertion.
5. Re-install both rear doors by lifting top of door into top track and swinging bottom of door onto bottom track. Install door labeled “inner door” first on inner track and door labeled “outer door” second on outer track.

Shelves and shelf light quantity

The shelves that are supplied with the case must be used to supply proper heat to pass sanitation requirements. Do not run case with shelves removed and replace bulbs as they burn out.

DOOR REMOVAL INSTRUCTIONS

ALL SERVICE CASES & SELF SERVE DRY

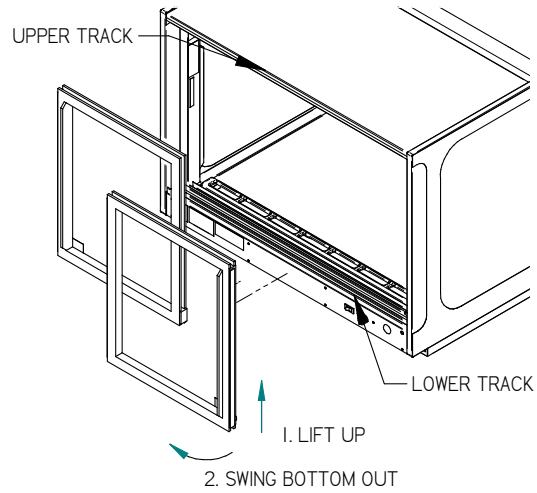

1. Start with the outer door and lift the door upward until the bottom edge of door clears the lower track and then swing the bottom of the door outward and down out of upper track.
2. After the outer door is removed repeat the procedure for the inner door.
3. Reverse this procedure for door reinstallation. The doors are not interchangeable.

OPERATING INSTRUCTIONS

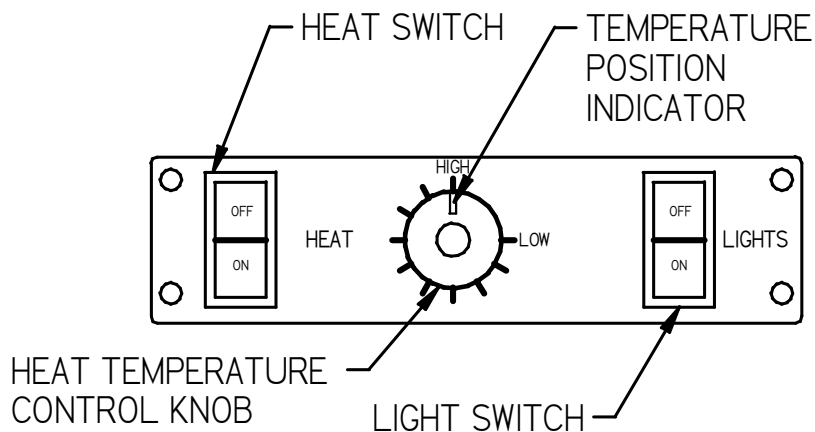

Controls (located either in back of case or behind sliding door on front of case)

Heat Switch

This switch controls all heating and humidity functions of the unit. This switch is on when the red portion of the switch is exposed. When this switch is on the deck and shelving heaters are on and their temperature is controlled by the Temperature Control. The humidity pan heater is also on and will stay on continuously.

Heat Temperature Control Knob

This control regulates the surface temperature of the deck and shelves that heat the product and interior air of the case. Turn counter-clockwise to operate the case at lowest temperature setting. The lowest setting will not allow the temperature to reach 140° F and should be used only for non-perishable food. Turn clockwise to operate the case at the highest temperature setting. The highest setting will allow the surface of the deck and shelves to reach temperatures in excess of 160° F and should be used to initially heat the case. If necessary, decrease the temperature by turning the control counter-clockwise no more than a quarter of a turn at a time. Allow 30 minutes for the heat in the case to balance.

Thermometer (located either inside rear upper corner of case or on front of case)

The thermometer reads the interior air temperature of the case. This temperature reading may be lower than actual product temperature due to higher surface temperature and the frequency of door openings. Exact food temperatures will be obtained by probing the food with a calibrated food thermometer with a range of at least 180° F.

Light Switch

This switch controls lights on the interior of the case. The switch is on when the red side of the switch is exposed. The lights operate independently of the heat control. Lights provide additional interior heat and should be used whenever the heat system is being used.

Water Pan (optional)

The water pan is located in the interior deck of the case and holds water to be used for humidifying the case air. The water pan must be filled manually if humidity is desired.

Shelves

Each display is furnished with shelves that are adjustable up and down and can be tilted in two angular positions. See "Shelving Installation & Removal" section of this manual for proper installation, adjustment and removal of shelving.

Rear Package Shelf Pedestal(optional)

The rear package shelf is provided with the 2-3/4” pedestal option. It is not adjustable up and down. And can be removed by loosening the retainer screws under the shelf and sliding out through key hole slots.

Initial Start-Up

After unit has been located, sealed to counter, and plugged into proper voltage supply, you are now ready to begin using your heated display case to serve your customers.

(Refer to Control Section in previous section for this instruction)

1. Clean the case thoroughly before proceeding as described in the “Weekly Cleaning Instruction” section of this manual.
2. If optional humidity system is provided in your case fill water pan with fresh, clean water as described in the “Water Pan Filling“ section of this manual. Using demonized water will minimize scale build-up.
3. Turn on heat switch.
4. Turn heat temperature control to clockwise to high position.
5. Turn on light switches to illuminate interior of case.
6. Allow time for case to reach proper temperature and stabilize. Place product in case once thermometer reaches a 150 Deg F.

Adjust heat temperature control until temperature indicator reaches desired temperature. Adjust case in small increments and allow 30 minutes for temperatures to equalize before making additional adjustments. Full clockwise is Maximum Temperature (approx 160Deg F) Full counter clockwise is Minimum Temperature (approx 110 Deg F with lights on). These temperatures will vary with ambient conditions and case size..



CAUTION: Temperatures of many types of food must not drop below set levels. Check local codes to determine minimum food temperature requirements in your area. The thermometer provided in the case interior measures air temperature only and the heated floor and shelf surfaces will be much hotter. Actual product temperature can only be monitored by occasionally probing product with a thermometer probe.

Placing Product into Case



WARNING: Interior surfaces are hot. DO NOT TOUCH.



NOTICE: Packaged product containers must be able to withstand temperatures of 200°F.



NOTICE: This case is designed to display preheated, precooked food products and is not intended to be used to bring refrigerated or frozen food to serving temperature. Food products being placed in case must be preheated to safe serving temperature. Check local code requirements in your area.

1. Once temperature levels have stabilized to desired conditions, place prepackaged preheated product into case. Allow enough spacing around product to allow proper circulation of heated air throughout the case.
2. Adjust temperature during peak serving periods to maintain proper product temperature.

Unit Shutdown

1. Remove all product from the case.



WARNING: Interior surfaces of case are hot. DO NOT TOUCH.

2. Turn interior lights off by placing light switch to the off position.
3. Turn heat control to low position. Allow heaters to cool down. (Mark dial location so temperature can be reset upon start-up.)
4. Turn heat switch off by placing heat switch to off position.

MAINTENANCE



CAUTION: Before any service work is performed on the case, make sure all power is disconnected to the case.



NOTICE: Installation and service of the electrical components in the case must be performed by a licensed electrician.

Service problems or request for repair parts from authorized service agencies, trained service personnel, or owners should be referred to:

CUSTOMER SERVICE DEPARTMENT

Federal Industries

215 Federal AVE

Belleville, WI 53508

Toll Free: (800) 356-4206 / WI Phone (608) 424-3331

Fax: (608) 424-3234

WATER PAN FILLING (OPTIONAL)

Depending on the amount of usage your heated display case receives will determine the frequency the water pan will need refilling. Water can be added at any time that is convenient for the operator. Refilling at regular intervals will provide the most consistent humidity level in the case.



CAUTION: Water in water pan is extremely hot. Do not touch surface of pan face and use caution when lifting water pan lid to avoid being burned from escaping hot steam.

1. Find a clean container, preferably with a handle and a pouring spout. Note: An empty water pan will hold approximately 1 gallon of water.
2. Fill a container with clean fresh water. Note: Using deionized water will minimize scale build-up on water heater components. If unit is running it is best to use warm or hot water to prevent cooling of case temperature and allowing less time for water to reach proper temperature.
3. Lift cover off of the water pan and slowly pour water into pan. Fill pan to top but do not allow water to overflow.



CAUTION: If any water is spilled during filling procedure wipe it up immediately to prevent a slippery floor condition.



CAUTION: Water pan cover is hot

4. Replace water pan cover and empty remaining water (if any) into sink or floor drain.



NOTICE: Water pan must be cleaned regularly to maintain proper performance and prevent mechanical failures. (See “CLEANING WATER PAN” section in this manual)

LIGHT BULB REPLACEMENT

Light bulbs are removed by unscrewing counter clockwise. Install bulbs by screwing in clockwise. Do not over tighten.

When replacing lights, use direct equivalent to the original bulbs. Bulbs must have protective coating to prevent shattering if broken.



NOTICE: Lights in this case are an additional source of heat and allow unit to heat to its maximum capacity. Replace burned out bulbs as soon as possible. Bulbs must have protective coating to prevent shattering if broken.

CLEANING INSTRUCTIONS

Acrylic Doors & Top Cleaning



NOTICE: Black acrylic top panel and optional front clear acrylic lift up doors require special washing procedures to prevent hazing and yellowing of material.

NEVER use paper towels (wet or dry) for cleaning or drying and never use a dry towel.

NEVER use glass cleaner of any kind.

Lightly dust (not wipe) surface with a damp Micro Fiber towel or chamois. The surface can then be washed using a small amount of dishwashing detergent such as Dawn or Joy and lukewarm water. Use a Micro Fiber towel or chamois, applying only light pressure. The cloth or chamois must be kept free of grit by frequently rinsing. Rinse surface with clear water and dry by blotting with a damp Micro Fiber towel or chamois.

Daily Cleaning

The case should be cleaned thoroughly, as described in the weekly cleaning section, before it is used for the first time.



NOTICE: Avoid splashing or soaking any electrical components with water to prevent electrical damage to the case.



NOTICE: Shut off lights and power switches and remove all product from case. Allow sufficient time for the unit to reach room temperature before proceeding with cleaning.



NOTICE: Remove all products from case before proceeding with cleaning procedure.



NOTICE: Black acrylic top panel and optional front clear lift up doors require special washing procedures to prevent hazing and yellowing of material. Read “Acrylic Doors & Top Cleaning” carefully.

Note: For major spills or foreign material buildup use the complete weekly cleaning instructions.

Note: Detergents are **not** recommended and do not use abrasive cleaners or pads to prevent scratching of surfaces.

1. Clean all foreign materials from the door opening.
2. Wipe complete interior of case using a damp cloth.
3. Clean black acrylic plastic top as described in “Acrylic Doors & Top Cleaning” section of this manual.
4. Clean end glass and glass front models using any common window cleaner.
Clean plastic lift up door models as described in “Acrylic Doors & Top Cleaning” section of this manual.
5. The remaining exterior surface should be wiped down using any soapy warm water.

Weekly Cleaning

This procedure is recommended on a weekly basis. It may need to be performed more often if necessary to maintain a clean, sanitary case. The case should be cleaned to this procedure before using the first time.



NOTICE: Avoid splashing or soaking any electrical components with water to prevent electrical damage to the case.



NOTICE: Shut off light and power switches and remove all product from case. Allow sufficient time for the unit to reach room temperature before proceeding with cleaning.



NOTICE: Black acrylic top panel and optional front clear lift up doors require special washing procedures to prevent hazing and yellowing of material. Read step 5 procedure carefully.

Interior Cleaning

Note: Detergents are **not** recommended and do not use abrasive cleaners or pads to prevent scratching of surfaces.

1. Remove both rear doors as described in the “Door Removal” section of this manual.
2. Remove all interior shelving as described in the shelving installation and removal section of this manual.
3. Remove both shelf standards from interior of case. First remove thumbscrew at bottom of shelf standard and then slide shelf standard up to allow top key slot to clear.
4. Clean the entire interior of the case using warm soapy water. Wipe off all soapy water with a damp cloth and allow to dry.

NOTE: Depending on the amount of usage and spillage of foreign material, some fasteners may have to be removed and parts disassembled to allow proper cleaning of the unit.

5. Clean all shelves, shelf support bars, shelf light housings, shelf brackets, and display pans using warm soapy water. Rinse thoroughly and allow to dry.
6. Clean all foreign material from inner and outer rear door tracks using warm soapy water. Apply a light film of lubricant such as PAM to make the doors operate smoother.
7. Clean both sides of the doors and interior of the front glass using any common window cleaner.
8. Clean black acrylic plastic inner top as described in “Acrylic Doors & Top Cleaning” section of this manual.
9. Clean interior of the end glass and glass front models using any common window cleaner. Clean interior of the plastic lift up door models as described in “Acrylic Doors & Top Cleaning” section of this manual.
10. Reassemble the case in reverse order starting with Step 6.

Exterior Cleaning

1. The exterior surfaces should be wiped down using any ammoniated cleansers or warm soapy water.
2. Clean black acrylic plastic outer top as described in “Acrylic Doors & Top Cleaning” section of this manual.
3. Clean exterior of the end glass and glass front models using any common window cleaner. Clean exterior of the plastic lift up door models as described in “Acrylic Doors & Top Cleaning” section of this manual.

CLEANING WATER PAN (SERVICE CASE ONLY)



WARNING: Be sure water and heater temperatures have cooled sufficiently before proceeding.



IMPORTANT: Water pan must be cleaned regularly to maintain proper performance and prevent mechanical failures.

NOTE: Using deionized water will minimize scale build-up on water pan components.

1. Remove pan cover from water pan and remove remaining water from pan with a sponge or towel.
2. Wash entire inside of pan and cover using soapy warm water. A mild cleanser and plastic-scouring pad may be required to clean water scale build-up. Rinse pan thoroughly after washing.
3. Reinstall cover.

SERVICE INFORMATION

CAUTION
RISK OF ELECTRIC SHOCK

DISCONNECT POWER
BEFORE SERVICING UNIT

Before any service work is performed on the case, make sure all power is disconnected to the case.

Service problems or request for repair parts from authorized service agencies, trained service personnel, or owners should be referred to:

CUSTOMER SERVICE DEPARTMENT
Federal Industries
215 Federal AVE
Belleville, WI 53508
Toll Free: (800) 356-4206 / WI Phone (608) 424-3331
Fax: (608) 424-3234

Pre-Service Checklist

You may avoid the cost and inconvenience of an unnecessary service call by first reviewing this checklist of frequently encountered situations that can cause unsatisfactory case performance. These items are not covered under warranty.



CAUTION: Before servicing case turn off power at the main breaker of fuse box.



CAUTION: Installation and service of the electrical components in the case must be performed by a licensed electrician.

Case Does Not Operate

Check for disconnected power supply.

Check for tripped breaker or blown fuse.

Lights Do Not Operate

Check that light switch is on.

Be sure light is properly seated in the sockets.

Check that shelf cord(s) are tight in the sockets.

Floor And Shelves Do Not Heat

Check that heat switch is on.

Check that thermostat is on high.

Check that shelf cord(s) are tight in the sockets.

Be sure that the rear doors are closed and tightly sealed.

Humidity Pan Does Not Heat Or No Humidity (Service Models only)

Check that heat switch is on.

Check water level in pan

Special Service Situations

If moisture or liquid is observed around or under a Federal Industries case, an immediate investigation should be made by qualified personnel to determine the source of the moisture or liquid. The investigation made should determine if the case is malfunctioning or if there is a simple housekeeping problem.

Moisture or liquid around or under a case is a potential slip/fall hazard for persons walking by or working in the general area of the case. Any case malfunction or housekeeping problem that creates a slip/fall hazard around or under a case should be corrected immediately.

SALE & DISPOSAL

Owner Responsibility

If you sell or give away your Federal Industries case you must make sure that all safety labels and the Installation-Service Manual are included with it. If you need replacement labels or manuals, Federal Industries will provide them free of charge. Contact the customer service department at Federal Industries at (800) 356-4206.

The customer service department at Federal Industries should be contacted at the time of sale or disposal of your case so records may be kept of its new location.

ELECTRICAL DATA

120 VOLT, 1PHASE, 60HERTZ	
MODEL	TOTAL AMPS
2428	7.2
3628	8.5
4828	11.0
2428SSD	7.2
3628SSD	10
4828SSD	12.5
2428SSD-2	5.3
3628SSD-2	7.0
4828SSD-2	8.9

Refer to the data plate attached to inside of the case for electrical requirements.

MAIN WIRING DIAGRAMS

120 VOLT (120VOLT)

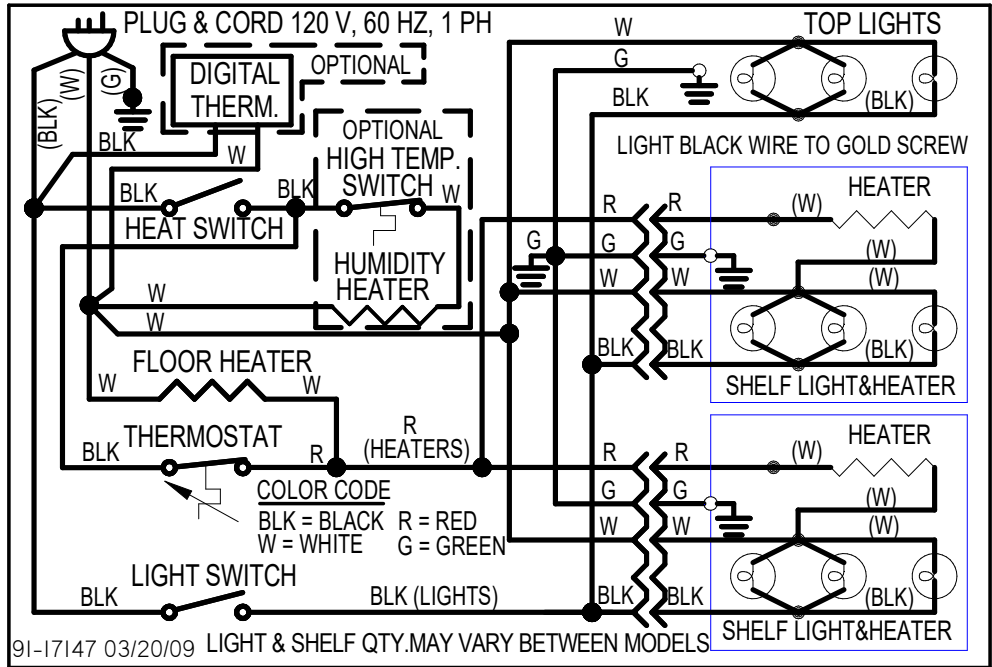

CH_28SSD-2 MODELS

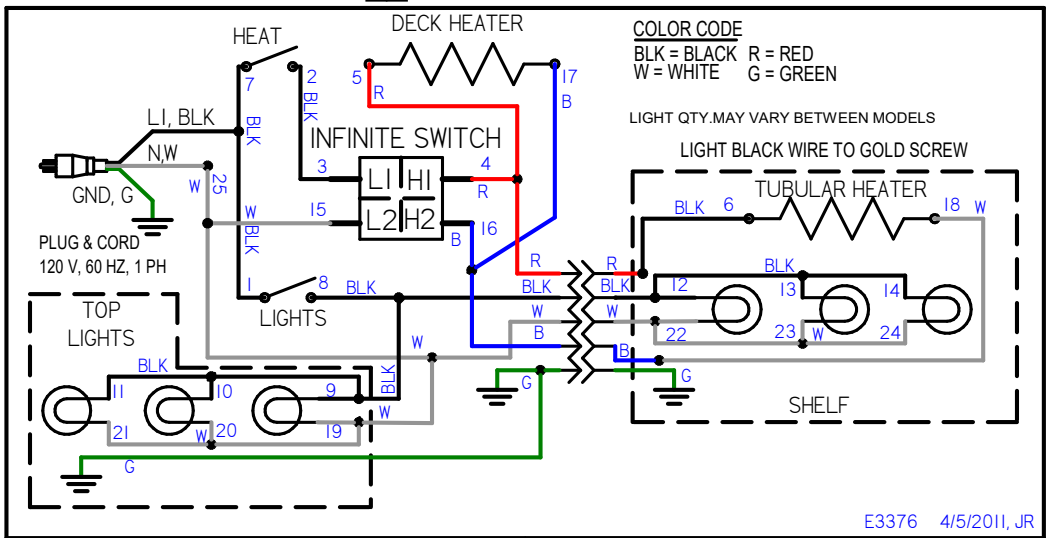

PARTS

	SERVICE MODELS			SELF-SERVE MODELS		
	2428	3628	4828	2428SSD	3628SSD	4828SSD
Light Switch	41-11066					
Heat Switch	41-11066					
Thermostat	41-19317					
Light Bulb	42-19089					
Bulb Receptacle	42-13649					
Thermometer	32-17181					
Opt. Digital Therm. & Bulb	32-18970					
Heater Top Shelf	40-18964-2	40-16029-3	40-16029-4	40-18964-2	40-16029-3	40-16029-4
Heater Bottom Shelf	40-18964-1	40-16029-1	40-16029-2	40-18964-1	40-16029-1	40-16029-2
Heater Floor W/ Humidity Pan	40-18965-1	40-17214-1	40-17214-2	40-18965-1	40-17214-1	40-17214-2
Heater Floor No Humidity Pan	40-18965	40-17214-3	40-17214-4	40-18965	40-17214-3	40-17214-4
Humidity Pan Heat	40-16027					
Humidity pan						
Thermostat Disk	41-17129					
Shelf light Cord	43-17140					
Shelf Receptacle Harness	43-17141					
Wiring Diagram	91-17147					
Power Cord	43-11302					
Shelf Bracket Top	67-16038-1A					
Shelf Bracket Bottom	67-16038-2A					
	SERVICE MODELS			SELF-SERVE MODELS		
CURVED GLASS	CH2428	CH3628	CH4828	CH2428SSD	CH3628SSD	CH4828SSD
Rear Door Inner Clear	53-17390-5	53-17390-1	53-17390-3	53-17390-5	53-17390-1	53-17390-3
Rear Door Inner Reflective	53-17390-6	53-17390-2	53-17390-4	53-17390-6	53-17390-2	53-17390-4
Rear Door Outer Clear	53-17391-5	53-17391-1	53-17391-3	53-17391-5	53-17391-1	53-17391-3
Rear Door Outer Reflective	53-17391-6	53-17391-2	53-17391-4	53-17391-6	53-17391-2	53-17391-4
End Panel Clear Left	51-17130-L	51-17130-L	51-17130-L	51-17130-L	51-17130-L	51-17130-L
End Panel Clear Right	51-17130-R	51-17130-R	51-17130-R	51-17130-R	51-17130-R	51-17130-R
End Panel Reflective Left	51-17230-L	51-17230-L	51-17230-L	51-17230-L	51-17230-L	51-17230-L
End Panel Reflective Right	51-17230-R	51-17230-R	51-17230-R	51-17230-R	51-17230-R	51-17230-R
End Panel Insulated	SA4147	SA4147	SA4147	SA4147	SA4147	SA4147
Glass Front	50-16023-1	50-16023-2	50-16023-3			
Door Front Top lift up				15-16036-3	15-16036-1	15-16036-2
Door Front Bottom lift up				15-16037-3	15-16037-1	15-16037-2
	SERVICE MODELS			SELF-SERVE MODELS		
STRAIGHT GLASS	EH2428	EH3628	EH4828	EH2428SSD	EH3628SSD	EH4828SSD
Rear Door Clear (2)	51-19173-1	51-19173-2	51-19173-3	51-19173-1	51-19173-2	51-19173-3
End Panel Clear Left	51-19175-L	51-19175-L	51-19175-L	51-19175-L	51-19175-L	51-19175-L
End Panel Clear Right	51-19175-R	51-19175-R	51-19175-R	51-19175-R	51-19175-R	51-19175-R
Glass Front	51-19174-5	51-19174-1	51-19174-3			
Glass Top	51-19174-6	51-19174-2	51-19174-4			
Door Front lift up				15-16037-3	15-16037-1	15-16037-2



SINGLE SHELF SELF SERVICE MODELS			
	2428SSD-2	3628SSD-2	4828SSD-2
Light Switch	41-11066		
Heat Switch	41-11066		
Infinite Control	41-10925		
Light Bulb	42-19089		
Bulb Receptacle	42-13649		
Thermometer	32-17181		
Heater Shelf	40-19314	40-19315	40-19316
Heater Floor	40-19309	40-19310	40-19311
Shelf light Cord	43-19330		
Shelf Receptacle Harness	43-19329		
Wiring Diagram	E3376		
Power Cord	43-11302		
Shelf Brackets	67-16038-1A		
Rear Door Inner Clear	53-17390-5	53-17390-1	53-17390-3
Rear Door Inner Reflective	53-17390-6	53-17390-2	53-17390-4
Rear Door Outer Clear	53-17391-5	53-17391-1	53-17391-3
Rear Door Outer Reflective	53-17391-6	53-17391-2	53-17391-4
End Panel Clear Left	51-17130-L	51-17130-L	51-17130-L
End Panel Clear Right	51-17130-R	51-17130-R	51-17130-R
End Panel Reflective Left	51-17230-L	51-17230-L	51-17230-L
End Panel Reflective Right	51-17230-R	51-17230-R	51-17230-R
End Panel Insulated	SA4147	SA4147	SA4147
Door Front Top lift up	15-19302-3	15-19302-1	15-19302-2
Door Front Bottom lift up	15-19303-3	15-19303-1	15-19303-2

California Residents Only.

⚠ WARNING

This product can expose you to chemicals including chromium which is known to the State of California to cause cancer and birth defects or other reproductive harm. For more information go to

www.P65Warnings.ca.gov