

**ThermoPro**  
Cook Like a Pro!



**Two-in-One Instant Infrared &  
Probe Thermometer**

420-V20240117 EN

## Introduction

Thank you for purchasing this Two-in-One Instant Infrared and Probe Thermometer. This two-in-one device lets you measure surface temperatures conveniently and accurately from a distance via infrared without the need of any direct contact and also measure internal temperature of food by inserting the probe into food to check whether the food is ready for serve.

## Components

- 1 x Two-in-One Instant Infrared and Probe Thermometer
- 2 x AAA Batteries
- 1 x User Manual

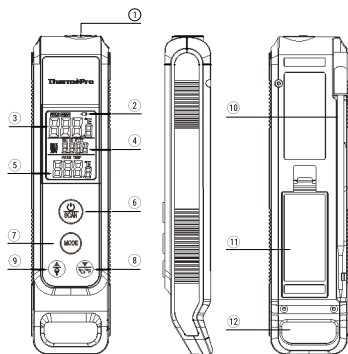

1. Infrared Sensor
2. Low Battery Indicator
3. Surface Temperature Measured via Infrared Sensor
4. MAX/MIN/AVG Temperature
5. Probe Temperature
6. : Press to turn on the device when it

is off. Press to scan and measure the temperature via infrared when the thermometer is ON.

7. Button: Press to cycle through the MAX/MIN/AVG temperature. Press and hold for 3 seconds to enter the emissivity adjustment mode.
8. : Press and hold for 3 seconds to select between °C and °F. When adjusting the emissivity, press the button to lower the emissivity.
9. : Press to turn on/off the backlight. When adjusting the emissivity, press the button to increase the emissivity.
10. Food Grade Stainless Steel Probe
11. Battery Compartment
12. Hanging Hole

## Specifications

Infrared Temperature Range	-58 to 1022°F (-50 to 550°C)
Tolerance	±3°F (±1.5°C) from 14 to 212°F (-10 to 100°C), otherwise ±2%
Response Time	500ms
Infrared Sensor Type	Thermopile Sensor
Distance-Spot Ratio	12:1
Probe Temperature Range	-58 to 572°F (-50 to 300°C)
Tolerance	±1.8°F (±1.0°C) from 32 to 212°F (0 to 100°C), otherwise ±1.5%
Probe Sensor Type	NTC
	Probe: 304 Stainless Steel, 4 <sup>1</sup> / <sub>4</sub> inches (107mm)

Response Time	2-3 seconds
Display	LCD: 1 $\frac{1}{2}$ " Length x 1 $\frac{1}{16}$ " Width inches (37 L x 27 W mm)
Backlight	Y
Unit Size	6 $\frac{5}{8}$ " Length x 1 $\frac{1}{8}$ " Width x 1 Height inches (167 L x 41 W x 25 H mm)
Power	3.0V (2 x AAA batteries)
<p>* Response Time defined as the time it takes for thermometers to read from ambient temperature (77°F or 25°C) to within 1.8°F (1°C) of final temperature of an object (150°F or 65°C). 150°F (65°C) is the recommended minimum temperature for many types of meat.</p>	





EN

## Installing/Replacing Batteries

Low Battery Indication will appear on the screen when the batteries are running low.

1. Open the Battery Compartment and remove the used batteries. Dispose of the used batteries properly.
2. Insert two new AAA batteries with the correct polarity.
3. Close the Battery Compartment.



## How to Measure Temperature via Infrared

1. Once the batteries are properly installed, press the  button to turn on the thermometer.
2. Press and hold  button to select between °C and °F.
3. Press and hold the  button to enter the emissivity adjustment mode. Press the  and  buttons to increase/decrease the emissivity. See the Emissivity Data Table listed in the end of this manual for the suggested emissivity

-03-

based on the object.

\* The emissivity of most organic materials and painted objects is 0.95. The default emissivity of this device is 0.95.

4. Point the thermometer towards the surface of the object you wish to measure.
5. Press the  button once to take the temperature on the surface you're pointing to, and the temperature will be shown on the upper part of the display.
6. Press and hold the  button if you wish to continually take a measurement of the surface. Press the  button to view the maximum, minimum and average temperature you measured during this measurement.
7. The last-measured temperature and MAX/MIN/AVERAGE temperature will remain on the display when you turn on the thermometer next time.

### NOTE:

1. The thermometer cannot measure the temperature of objects behind glass. Inaccuracy may also occur when exposed to steam, dust, or any other contaminants in the air.
2. The thermometer only measures the surface temperature of the objects via infrared. If you need to measure the internal temperature of something (like meat, food etc.), use the probe as described below.

## How to Measure the Food/Meat Internal Temperature via Probe

1. Press the  button to turn on the thermometer.

EN

-04-

2. Pull out the probe and the temperature measured by the probe will show on the bottom part of the display.
3. Insert the probe into the meat, and the internal temperature will show after a few seconds.
4. If the probe is retracted, the probe temperature will display "----".

### Auto-off Feature

If no button is pressed and the probe is not being used to measure the temperature, the thermometer will turn off automatically in 90 seconds.

### Distance-Spot Ratio

The thermometer measures surface temperature based on the distance to spot diameter ratio (D:S). As the distance between the thermometer and the surface increases, the total surface area measured will also increase. For example, with a distance to spot ratio of 12:1, the surface area measured has a diameter of roughly 1/12 of the distance.

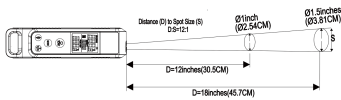

For the most accurate results, make sure the target has a surface area of twice the corresponding spot diameter. Insufficient surface area will result in inaccuracies. For example, if you use a device with DS ratio 12 to measure an area with a diameter 1 inch (or 25.4mm), the recommended distance to hold the thermometer from the surface of

measurement is 6 inches (152mm) or shorter away from the surface.

### Emissivity

The emissivity of a material is its efficiency in emitting thermal energy. Non-reflective surfaces have a higher emissivity (closer to 1) than reflective surfaces (closer to 0). Inaccurate results may occur when measuring reflective surfaces such as glass, polished wood, and granite.

To take accurate temperature measurement of reflective surfaces with low emissivity, place a strip of masking tape over the surface and allow for it to adjust to the temperature of the surface for approximately 30 minutes. Measure the surface, scanning the taped section, eliminating the issue of inaccuracy.

The emissivity of most organic materials and painted objects is 0.95. The default emissivity of this device is 0.95, no need to modify. If you would like to improve the measurement accuracy of different objects, you can refer to the emissivity data table below.

Objects	Emissivity	Objects	Emissivity
Aluminum	0.30	Iron	0.70
Asbestos	0.95	Lead	0.50
Asphalt	0.95	Limestone	0.98
Basalt	0.70	Oil	0.94
Brass	0.50	Paint	0.93
Brick	0.90	Paper	0.95
Carbon	0.85	Plastic	0.95

Ceramics	0.95	Rubber	0.95
Concrete	0.95	Sand	0.90
Copper	0.95	Stone	0.70
Sludge	0.94	Snow	0.90
Frozen Food	0.90	Steel	0.80
Hot Food	0.93	Fabric	0.94
Glass	0.85	Water	0.93
Ice	0.98	Wood	0.94

EN

## Safe Use & Care

DO NOT point at any person or animal.

DO NOT attempt to point at an aircraft.

DO NOT allow children to operate the device.

Use two 1.5V AAA batteries when replacing the batteries within the device.

Make sure to insert the batteries in accordance with the correct polarities.

ALWAYS remove the batteries when cleaning the device.

DO NOT use leaking batteries or dispose of old batteries in fire.

Remove the batteries if storing the device for a prolonged period of time.

DO NOT disassemble the device or tamper with internal components. Doing so will void any warranty.

DO NOT touch the lens or wipe it using anything other than a soft cloth or cotton swab.

Keep the thermometer away from electromagnetic fields produced by objects such as arc welders and induction heaters.

-07-

DO NOT expose the thermometer to direct sources of heat for extended periods of time.

The thermometer measures surface temperature, not internal temperature.

Do not use it as a reliable source to measure body temperatures.

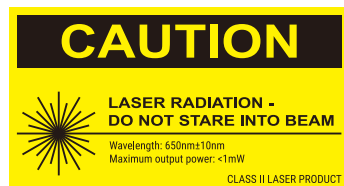

EN

\* The maximum output power emitted through the laser aperture is 85uW.

**Caution**—use of controls or adjustments or performance of procedures other than those specified herein may result in hazardous radiation exposure.

## Disposal



You can help protect the environment! Please remember to respect the local regulations. Hand in the non-working electrical

equipment to an appropriate waste disposal center. Do not use it as a reliable source to measure body temperatures.

## EC Conformity



Hereby, the manufacturer declares that this product complies with the basic requirements and applicable

-08-

regulations of the Radio Equipment Directive 2014/53/EU, the EMC Directive 2014/30/EU. The complete declaration of conformity can be found at:  
<https://buythermopro.com/eu-declaration-of-conformity/>.

## Limited One-Year Warranty

ThermoPro warrants this product to be free of defects in parts, materials and workmanship for a period of one year, from date of purchase.

EN

Should any repairs or servicing under this warranty be required, contact Customer Service by phone or email for instructions on how to pack and ship the product to ThermoPro.

This warranty gives you specific legal rights and you may also have other rights which vary from state to state.

## Customer Service

Call or Text: 1-877-515-7797  
(USA & Canada only)  
44-808-164-1683(UK)

Email: [service@buythermopro.com](mailto:service@buythermopro.com)

Hours: Weekdays 8:00AM - 8:00PM EST  
(USA & Canada only)  
Weekdays 1:00PM - 12:00PM  
CET(UK)