

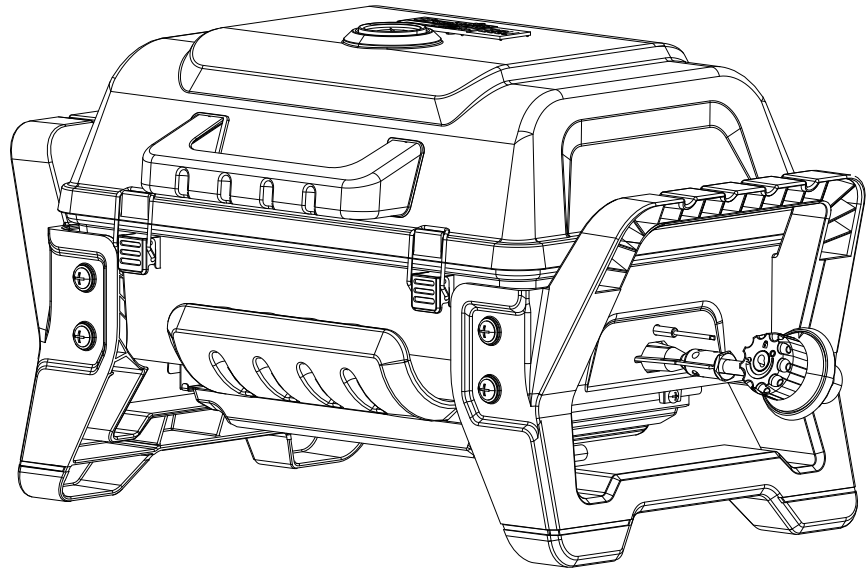

GRILL2GO X200

MODEL NUMBERS
13401871

Product Guide



IMPORTANT: Fill out the product record information below.

Serial Number _____
See rating label on unit for serial number.

Date Purchased _____

Note: Sales docket must be kept as proof of purchase date.

For use with propane gas only

For Outdoor Use Only

For support with your new
barbecue, please call us at
OZtrail Leisure Products (07) 3279 1800
or e-mail at service@oztrail.com.au

Important: Read these instructions for use carefully. Familiarise yourself with the appliance before connecting it to its gas container. Keep these instructions for future reference.

TABLE OF CONTENTS



Product Record Information 1
 For Your Safety 2
 Safety Symbols 2
 Installation Safety Precautions 3-4
 Use and Care 5-9
 Food Safety 9
 Limited Warranty 10
 Parts List 11
 Parts Diagram 12
 Removable Parts Assembly 13
 Troubleshooting 14-15

Safety Symbols

The symbols and boxes shown below explain what each heading means. Read and follow all of the messages found throughout the manual.

 **DANGER** 

DANGER: Indicates an imminently hazardous situation which, if not avoided, will result in death or serious injury.

 **WARNING** 

WARNING: Indicates a potentially hazardous situation which, if not avoided, could result in death or serious injury.

 **CAUTION:** 

CAUTION: Indicates a potentially hazardous situation or unsafe practice which, if not avoided, may result in minor or moderate injury.

 **CAUTION** 



For residential use only. Do not use for commercial cooking.

INSTALLER/ASSEMBLER:

Leave this manual with consumer.



CONSUMER:

Keep this manual for future reference.

 **DANGER** 

1. Never operate this barbecue unattended.
2. Never operate this barbecue within 3m of any structure, combustible material or other gas container.
3. Never operate this barbecue within 7.5 m of any flammable liquid.
4. If a fire should occur, keep away from the barbecue and immediately call your fire department. Do not attempt to extinguish an oil or grease fire with water.

Failure to follow these instructions could result in fire, explosion or burn hazard, which could cause property damage, personal injury or death.

 **DANGER** 

If you smell gas:

1. Shut off gas to the barbecue.
2. Extinguish any open flame.
3. Open lid.
4. If odour continues, keep away from the barbecue and immediately call your gas supplier or your fire department.

Failure to follow these instructions could result in fire or explosion, which could cause property damage, personal injury or death.

THIS BARBECUE IS FOR OUTDOOR USE ONLY.

 **WARNING** 

Failure to follow all manufacturer's instructions could result in serious personal injury and/or property damage.

 **CAUTION** 

Read and follow all safety statements, assembly instructions, and use and care directions before attempting to assemble and cook.

 **CAUTION** 

Some parts may contain sharp edges. Wear protective gloves if necessary.



INSTALLATION SAFETY PRECAUTIONS

Installation Safety Precautions

- Use barbecue, as purchased, only with LP (propane) gas and the regulator/valve assembly supplied.
 - This barbecue is not for use in or on caravans and/or boats.
 - This barbecue will be hot during and after use. Use insulated oven mitts or gloves for protection from hot surfaces or splatter from cooking liquids.
 - Total Gas consumption - 10 MJ/h
Injector size 0,8mm
 - This barbecue shall only be used with a propane, non-refillable container, certified to UL 147A/B with a maximum capacity of 465g.
- IT MAY BE HAZARDOUS TO ATTEMPT TO FIT OTHER TYPES OF GAS CONTAINERS.

ONLY USE IN WELL-VENTILATED AREAS

CARBON MONOXIDE HAZARD - THIS BARBECUE CAN PRODUCE CARBON MONOXIDE WHICH HAS NO ODOUR. USING IT IN AN ENCLOSED SPACE (FOR EXAMPLE, CARAVAN, TENT, CAR, MOBILE HOUSE) MAY CAUSE DEATH.

USE OUTDOORS ONLY

This barbecue shall only be used in an above ground open air situation with natural ventilation, without stagnant areas, where gas leakage and products of combustion are rapidly dispersed by wind and natural convection.
(See page 4 for details)

WARNING

- Outdoor gas barbecue is not intended to be installed in or on a boat.
- Outdoor gas barbecue is not intended to be installed in or on an caravan.
- Never attempt to attach this barbecue to the self-contained gas system of a caravan.
- Do not use barbecue until leak-tested.
- If a leak is detected at any time, STOP.
- If you cannot stop a gas leak, *immediately* close gas container valve and call gas supplier or your fire department!

WARNING

Do not attempt to repair or alter the regulator/valve for any “assumed” defect. Any modification to this assembly will void your warranty and create the risk of a gas leak and fire. Use only authorized replacement parts supplied by manufacturer.

	CAUTION	
<ul style="list-style-type: none">• For residential use only. Not intended for commercial use.• Do not leave barbecue unattended. Keep children and pets away from barbecue at all times.• Do not modify this barbecue.		

	CAUTION	
<p>Accessible parts may be very hot. Keep young children away.</p>		

	CAUTION	
<p>If barbecue should go out accidentally, turn the burner control OFF, wait 5 minutes and repeat the lighting procedure.</p>		

	CAUTION	
<p>This barbecue must only be serviced by an authorized person.</p>		

Seal Checks

Check that seals between the appliance and gas container are in place and in good condition before connecting gas container.

If this seal is damaged or missing obtain a replacement regulator. Do not attempt to repair or replace.

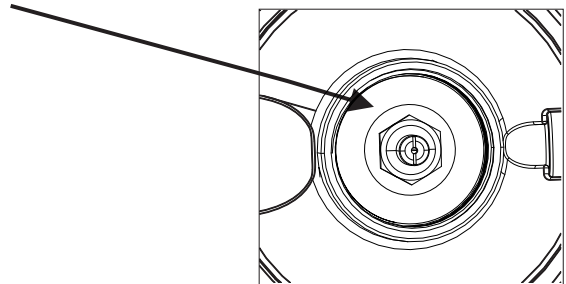

Do not use this appliance if it has damaged or worn seals. Do not use this appliance if it is leaking, damaged, or does not operate properly.

For support with your new barbecue, please call us at OZtrail Leisure Products (07) 3279 1800 or e-mail at service@oztrail.com.au

The appliance is certified to AS 2658 by SAI Global file GAS 40070



THIS barbecue SHALL ONLY BE USED IN AN ABOVE GROUND OPEN AIR SITUATION WITH NATURAL VENTILATION, WITHOUT STAGNANT AREAS, WHERE GAS LEAKAGE AND PRODUCTS OF COMBUSTION ARE RAPIDLY DISPERSED BY WIND AND NATURAL CONVECTION.

ANY ENCLOSURE IN WHICH THE barbecue IS USED SHALL COMPLY WITH ONE OF THE FOLLOWING:

- AN ENCLOSURE WITH WALLS ON ALL SIDES, BUT AT LEAST ONE PERMANENT OPENING AT GROUND LEVEL AND NO OVERHEAD COVER
 - WITHIN A PARTIAL ENCLOSURE THAT INCLUDES AN OVERHEAD COVER AND NO MORE THAN TWO WALLS
 - WITHIN A PARTIAL ENCLOSURE THAT INCLUDES AN OVERHEAD COVER AND MORE THAN TWO WALLS, THE FOLLOWING SHALL APPLY:
 - (i) AT LEAST 25% OF THE TOTAL WALL AREA IS COMPLETELY OPEN: AND
 - (ii) AT LEAST 30% OF THE REMAINING WALL AREA IS OPEN AND UNRESTRICTED
 - IN THE CASE OF BALCONIES, AT LEAST 20% OF THE TOTAL OF THE SIDE, BACK AND FRONT WALL AREAS SHALL BE AND REMAIN OPEN AND UNRESTRICTED
 - DO NOT USE YOUR BARBECUE IN GARAGES, PORCHES, BREEZEWAYS, SHEDS OR OTHER ENCLOSED AREAS.
- YOUR BARBECUE IS TO BE USED OUTDOORS ONLY. Refer below.**
- THE BARBECUE IS NOT INTENDED TO BE INSTALLED IN OR USED ON RECREATIONAL VEHICLES AND/OR BOATS AND SHOULD NOT BE PLACED ADJACENT TO OR UNDER ANY SURFACE THAT WILL BURN.
 - DO NOT OBSTRUCT THE FLOW OF COMBUSTION AND VENTILATION AIR AROUND THE BARBECUE HOUSING WHILST IN USE.

The following diagrams are examples of outdoor areas.
These same principles apply to canopy or shaded cloth areas.

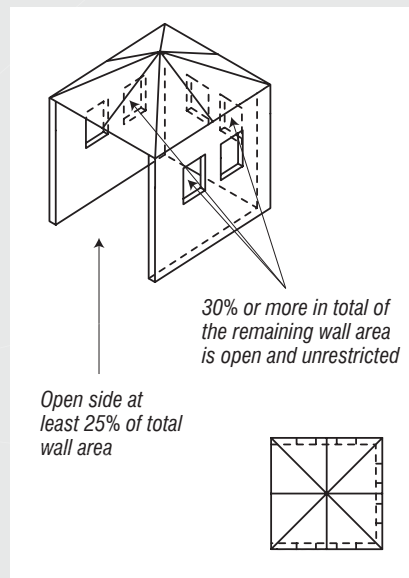
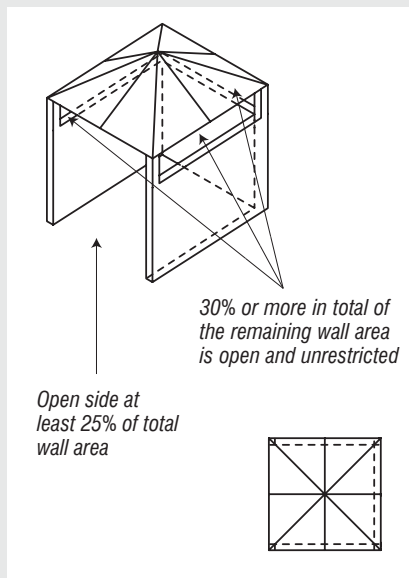
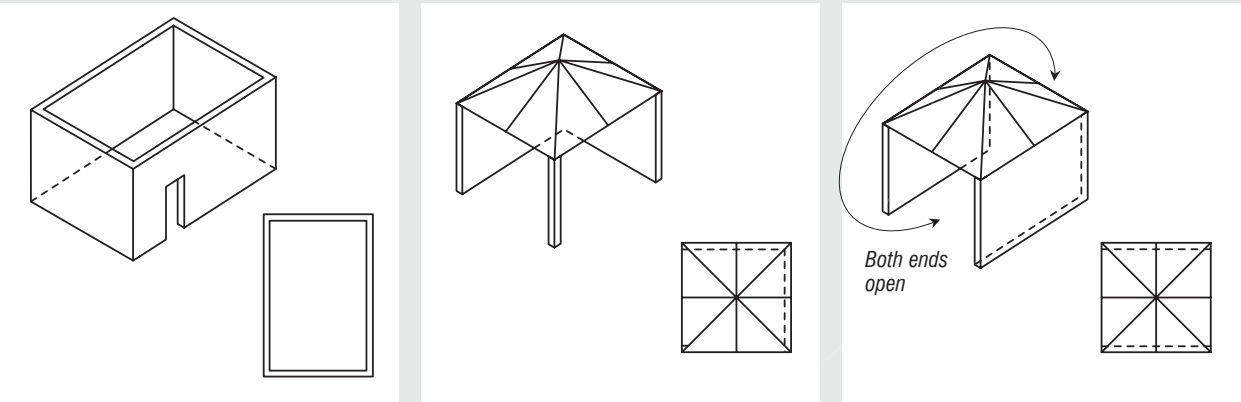

USE AND CARE



WARNING



For Safe Use of Your Barbecue and to Avoid Serious Injury:

- Do not let children operate or play near barbecue.
- Keep barbecue area clear and free from materials that burn (i.e. petrol, propane, or other flammable liquid or gas).
- Do not block holes in bottom or back of barbecue.
- Check burner flames regularly.
- Never use regulator from this barbecue with any other LP barbecue.
- The appliance is to be operated on a horizontal surface unless it is designed to be suspended during operation.
- Gas containers shall be changed in a well-ventilated location, preferably outside away from people and any source of ignition, such as naked flames, pilot flames, electric heaters/equipment.
- Use barbecue only in well-ventilated space. For outdoor use only. NEVER use in an enclosed space such as carport, garage, porch, covered patio, or under an overhead structure of any kind.
- Do not use charcoal or ceramic briquets in a gas barbecue.
- This barbecue is not intended for and should never be used as a heater.
- Do not cover grates with aluminum foil or any other material. This will block burner ventilation and create a potentially dangerous condition resulting in property damage and/or personal injury.
- **Use barbecue at least 1m from any wall or surface.** Maintain 3m clearance to objects that can catch fire or sources of ignition such as pilot lights on water heaters, live electrical appliances, etc..

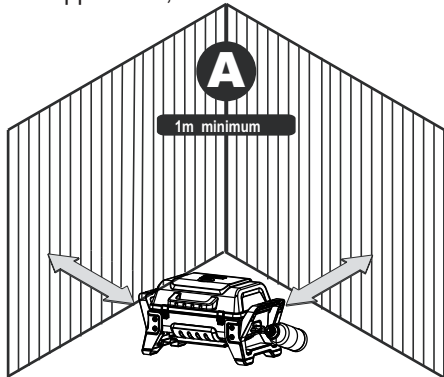

• Apartment Dwellers:

Check with management to learn the requirements and fire codes for using an LP gas barbecue in your apartment complex. If allowed, use outside on ground floor with a one (1) meter clearance from walls or rails. Do not use on or under balconies.

- **NEVER attempt to light burner with lid closed. A buildup of non-ignited gas inside a closed barbecue is hazardous.**
- **Never operate barbecue with LP container out of correct position specified in assembly instructions.**

LP (Liquefied Petroleum Gas)

- Is nontoxic, odourless and colorless when produced. **For Your Safety**, LP gas has been given an odour (similar to rotten cabbage) so that it can be smelled.
- **LP gas is highly flammable and may ignite unexpectedly when mixed with air.**

Propane Container Use (465g Disposable)

- Use only container marked "Propane Fuel".
- Container must be constructed and marked with UL 147 A/B non-refillable of 465g capacity.
- Size should be 10cm dia, and 20cm in height.
- Save container cap and reinstall when not in use.
- Container supply system must be arranged for vapor withdrawal. Gas container must be upright in use.

Note: The fuel level in a container can be checked by either weighing the container or shaking and feeling for liquid.



CAUTION



If the burner flame should be extinguished accidentally, turn the control knob to the OFF position and open the lid. DO NOT press the ignitor button. Wait 5 minutes before attempting to relight the barbecue.

LP Gas Container Installation/Removal

LP Gas Container Installation:

1. Remove cap from end of Propane container (sold separately).
2. Cap should be kept on container when not in use to prevent dirt and debris from entering Regulator/Valve.
3. Check end of container attachment for dirt and debris. Clean out if necessary.
4. Insert threaded end of LP Gas Container into Regulator/Valve and hand-tighten turning container clockwise as shown below.
DO NOT USE TOOLS! Over tightening can damage threads on Regulator/Valve.

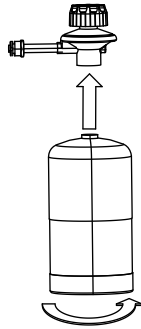

Regulator/Valve Installation/Removal

1. With knob pointing to back of barbecue, insert Regulator/Valve into end of burner (A)
Notch in Regulator/Valve MUST engage dimple in end of burner.
2. Once Regulator/Valve has completely engaged burner, turn Regulator/Valve clockwise (B) to lock in position with knob pointing as shown (C).
3. To remove reverse steps.

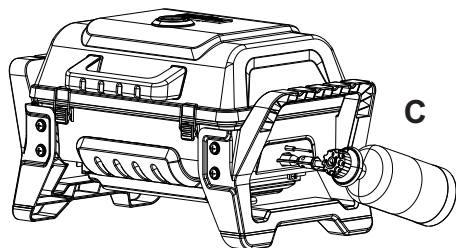
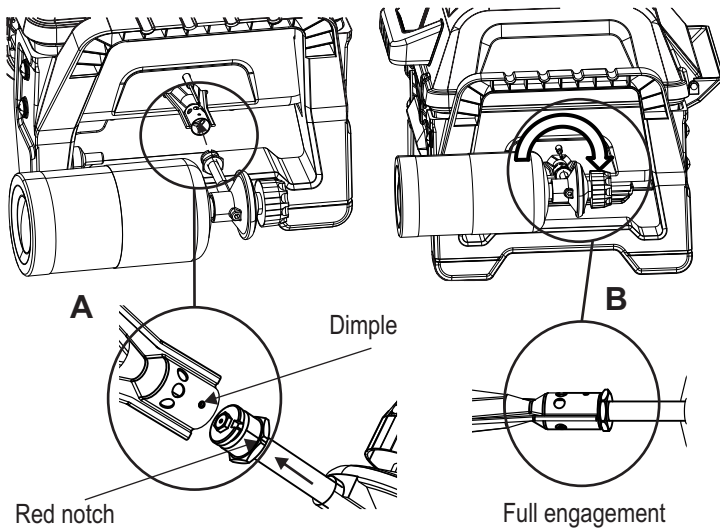

Leak Testing (465g. Disposable) **IMPORTANT!**

- During leak test, keep barbecue away from open flames or sparks and do not smoke. Barbecue must be leak tested outdoors in a well ventilated area.
 - Leak test must be repeated each time gas container is replaced or after storage.
- Materials needed include clean paint brush and 50/50 soap and water solution. Use mild soap and water. **Do not use household cleaning agents.** Damage to components can result.

1. Be sure **control knob** on regulator is in  position.
 2. Brush soapy solution onto **connection** between gas container and regulator at (A).
 3. Brush soapy solution onto **connection** between regulator pipe threads and regulator, and burner tube and orifice at (B).
- If growing bubbles appear, there is a leak. Retighten connections and repeat steps 1, 2, and 3.

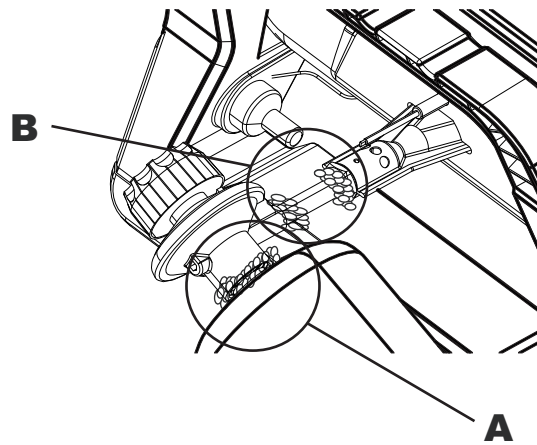

If you cannot stop a leak, remove gas container from regulator and check for damaged threads, dirt and debris on regulator and gas container. Also check to see if anything is obstructing flow of gas at regulator and gas container openings. Remove any obstruction that may be found and repeat leak test. If threads are damaged on either regulator or gas container, replace. If there is a leak from your appliance (smell of gas) and you cannot stop the gas flow, remove the appliance to a well-ventilated location away from any ignition source. Check for leaks using soapy water. Do not try to detect leaks using a flame.

Call OZtrail Leisure Products at (07) 3279 1800 for replacement parts to correct leaks.

IMPORTANT: REMOVE PROPANE CONTAINER FROM REGULATOR/VALVE WHEN NOT IN USE.

Propane Container Removal:

1. Turn regulator control knob to .
2. Allow barbecue to cool.
3. Remove the propane container by turning counter-clockwise until disengaged from the Regulator/Valve.
4. Install cap on container. Cap should be kept on container when not in use to prevent dirt and debris from entering Regulator/Valve.



DANGER



- NEVER store a spare container under or near the appliance or in an enclosed area.
- Never fill a container beyond 80% full.
- An overfilled or improperly stored cylinder is a hazard due to possible gas release from the safety relief valve. This could cause an intense fire with risk of property damage, serious injury or death.
- If you see, smell or hear gas escaping, immediately get away from the LP container/appliance and call your fire department.

Safety Tips

- The use of alcohol, prescription or nonprescription drugs may impair the consumer's ability to properly assemble or safely operate the barbecue.
- When barbecue is not in use, disconnect 465g container.
- Never move barbecue while in operation or still hot. Allow the barbecue to cool before moving or storing.
- The regulator may make a humming or whistling noise during operation. This will not affect safety or use of barbecue.
- If you have a barbecue problem see the Troubleshooting Section.
- Light burner. Check to make sure it is lit, close the lid and warm up barbecue on high for 10 minutes. Curing of paint and parts will produce an odour only on first lighting.
- barbecue is not to be used as a heater.
- This barbecue will be hot during and after use. Use insulated oven mitts or gloves for protection from hot surfaces or splatter from cooking liquids.
- Clean barbecue often, preferably after each cookout. If a bristle brush is used to clean any of the barbecue cooking surfaces, ensure no loose bristles remain on cooking surfaces prior to barbecuing. It is not recommended to clean cooking surfaces while barbecue is hot.

Ignitor Lighting

READ INSTRUCTIONS BEFORE LIGHTING.

Do NOT lean over barbecue while lighting.

1. Turn gas regulator control knob to ○.
2. Connect LP gas container.
3. **Open** the barbecue lid.
4. Press and turn the control knob to the 🔥 position. Push ignitor button rapidly.
5. Once the burner has ignited, turn the regulator control knob to the desired setting.
6. If ignition does not occur in 5 seconds, turn the regulator control knob to ○, wait 5 minutes, and repeat lighting procedure.

If ignition still does not occur, follow match-lighting instructions.



CAUTION



If ignition does NOT occur in 5 seconds, turn the regulator control knob to ○, wait 5 minutes and repeat the lighting procedure. If the burner does not ignite with the regulator control knob open, gas will continue to flow out of the burner and could accidentally ignite with risk of injury.

Match Lighting

1. Insert lit match into match hole in barbecue end, next to burner. Turn regulator control knob to setting 🔥.
2. If ignition does NOT occur in 5 seconds, turn the regulator control knob to ○, wait 5 minutes and repeat the lighting procedure.

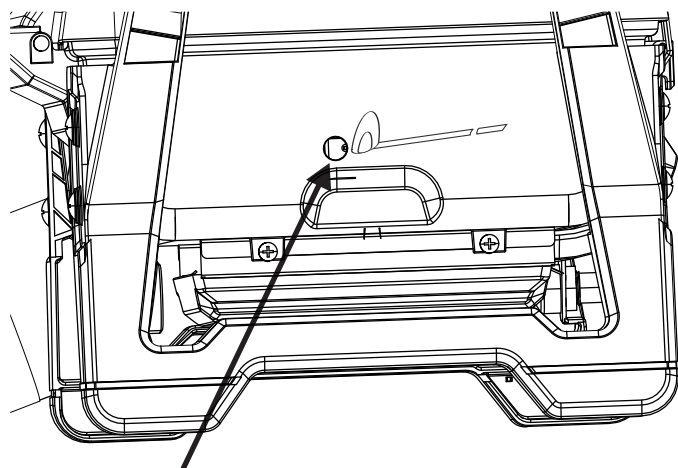

Match Light Hole

Turning barbecue Off

Turn control knob to ○ position. Disconnect LP container.

Burner Flame Check

- Light burner. Looking through the match light hole, end of barbecue, you should see the flame height as shown below. Turn control knob from position HIGH to LOW. The Flame height should decrease. Always check flame prior to each use. If only low flame is seen refer to "Low flame, drop in gas flow" in the Troubleshooting Section.

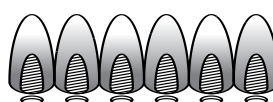

High Flame



Low Flame

Ignitor Check

- **Remove LP container.** Push ignitor button. "Click" should be heard each time at electrode. See "Troubleshooting" if no click or spark.



CAUTION



NATURAL HAZARD • SPIDERS

FACT: Some times spiders and other small insects climb into the burner tubes attached to the burner. The spiders spin webs, build nests and lay eggs. The webs or nests can be very small, but they are very strong and can block the flow of gas. Clean burner prior to use after storing, at the beginning of barbecuing season or after a period of one month not being used.

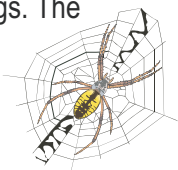

Spider guards are on the air intakes in an effort to reduce this problem, but it will not eliminate it! An obstruction can result in a "flashback" (a fire in the burner tubes). The barbecue may still light, but the obstruction does not allow full gas flow to the burner.

IF YOU EXPERIENCE THE FOLLOWING:

1. Smell gas.
2. Burner(s) will not light.
3. A small yellow flame from burner (should be blue).
4. Fire coming from around burner regulator connection.

STOP!

Immediately turn off gas at gas container!

SOLUTION:

Wait for barbecue to cool.

Follow the "Cleaning the Burner Assembly" instructions. Clean burner often. Use a 12" pipe cleaner to clean out the burner tube. You may also force a stream of water from a hose nozzle through burner tube to clean.

Cleaning The Burner Assembly

1. Turn gas off at regulator control knob and disconnect Lp container.
2. Remove cooking grid.
3. Remove regulator from burner tube by (1) rotating regulator until knob is to back of barbecue and then (2) by pulling outward. Shown **FIG. A**
4. Wipe ceramic electrode with rubbing alcohol and cloth. Clean burner exterior with soap and water. insert garden hose (preferably with nozzle), into burner tube forcing water through tube. Make sure water comes out of every porthole. Open clogged portholes with a thin wire. **Allow burner to dry thoroughly** and examine portholes. Due to normal wear and corrosion some portholes may become enlarged, if so replace burner. If any horizontal cracks appear from porthole to porthole or large holes (other than portholes) are found replace burner.
5. If barbecue is to be stored, coat burner lightly with cooking oil. Wrap in protective cover to keep insects out. If not storing use following steps.
6. Reattach Regulator.
7. Replace cooking grid.
8. Before cooking again on barbecue, perform a "Leak Test" and "Burner Flame Check".

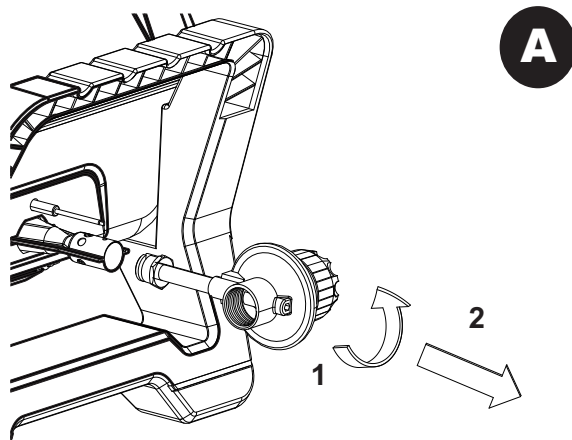

Proper Grate Orientation

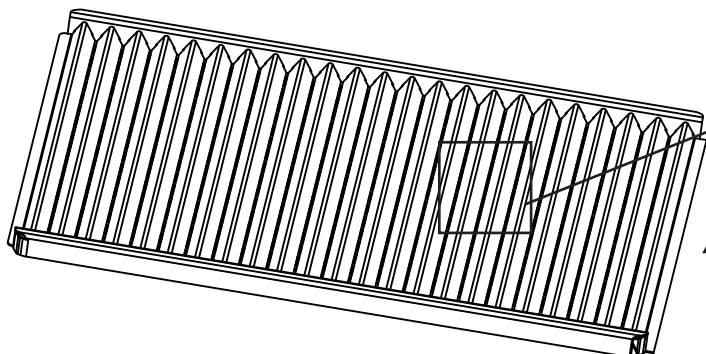

Cooking grate up slots on bottom

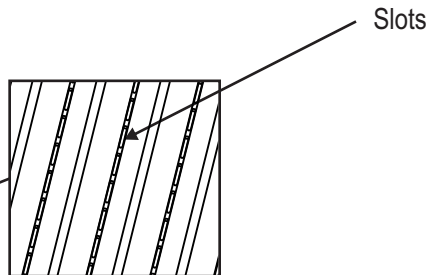

	CAUTION	
<h2 style="margin: 0;"><i>Grease Fires</i></h2>		
<ul style="list-style-type: none"> • Putting out grease fires by closing the lid is not possible. Barbecues are well ventilated for safety reasons. • Do not use water on a grease fire. Personal injury may result. If a grease fire develops, turn burner control knob off. • If barbecue has not been regularly cleaned, a grease fire can occur that may damage the product. Pay close attention while preheating or burning off food residue to ensure that a grease fire does not develop. Follow instructions on General Barbecue Cleaning and Cleaning The Burner Assembly to prevent grease fires. • The best way to prevent grease fires is regular cleaning of the barbecue. 		

General Barbecue Cleaning

- Do not mistake brown or black accumulation of grease and smoke for paint. Interiors of gas barbecues are not painted at the factory (and should never be painted). Apply a strong solution of detergent and water or use a barbecue cleaner with scrub brush on insides of barbecue lid and bottom. Rinse and allow to completely air dry. **Do not apply a caustic barbecue/oven cleaner to painted surfaces.**

Storing Your Barbecue

- Clean cooking surface.
- When LP container is connected to barbecue, store outdoors in well-ventilated space and out of reach of children.
- Cover barbecue if stored outdoors.
- Any indoor storage shall comply with AS/NZS 1596. Store barbecue indoors ONLY if LP container is disconnected.
- Leak test the barbecue after removing from storage and follow Cleaning Burner Assembly instructions before starting barbecue.
- Keep barbecue area clear and free from materials that burn (ie. petrol, propane or other flammable liquid or gas).
- Do not block holes in bottom or back of barbecue.

	WARNING	
<p>Turn controls OFF  and disconnect container when not in use.</p>		

Before Your First Cookout

Leak test your barbecue. Light burner, check to make sure it is lit. Close the lid and warm up 5 for 10 minutes. Additional curing of paints and parts will produce an odour only on first lighting.

Food Safety

Food safety is a very important part of enjoying the outdoor cooking experience. To keep food safe from harmful bacteria, follow these four basic steps:

Clean: Wash hands, utensils, and surfaces with hot soapy water before and after handling raw meat and poultry.

Separate: Separate raw meats and poultry from ready-to-eat foods to avoid cross contamination. Use a clean platter and utensils when removing cooked foods.

Cook: Cook meat and poultry thoroughly to kill bacteria. Use a thermometer to ensure proper internal food temperatures.

Chill: Refrigerate prepared foods and leftovers promptly.

How To Tell If Meat Is Cooked Thoroughly

- Meat and poultry cooked in the barbecue often browns very fast on the outside. Use only thawed meat and a meat thermometer to be sure food has reached a safe internal temperature, and cut into food to check for visual signs of doneness.
- We recommend food to be at least 4°C before cooking in your barbecue.
- Whole poultry should reach 74° C. Juices should run clear and flesh should not be pink.
- Beef, veal and lamb steaks, roasts and pork chops can be cooked to 71° C.
- NEVER partially cook meat or poultry and finish cooking later. Cook food completely to destroy harmful bacteria.
- Use a meat thermometer to ensure proper internal food temperatures.

Recommended Maintenance

- Clean cooking grate at each use.
- Clean/Inspect firebox at each use.
- Clean/Inspect heat tent at each use.
- Check seals prior to each use.
- Check regulator for leaks.
- Check that all gas fittings are tight at each use.
- Clean/Inspect burners and venturis every 6 months.

LIMITED WARRANTY

The benefits under this manufacturer's warranty are in addition to other rights and remedies under law in relation to goods. Manufacturer warrants to the **original consumer-purchaser** only that this product shall be free from defects in workmanship and materials after correct assembly and under normal and reasonable home use for the periods indicated below beginning on the date of purchase*. The manufacturer reserves the right to require that defective parts be returned, postage and or freight pre-paid by the consumer for review and examination.

<u>SCOPE OF COVERAGE</u>	<u>PERIOD OF COVERAGE</u>	<u>TYPE OF FAILURE COVERAGE</u>
Stainless Burner	2 years from date of purchase*	PERFORATION, MANUFACTURING, AND MATERIAL DEFECTS ONLY
Firebox and Lid	2 years from date of purchase*	
All Other Parts	1 year from date of purchase*	

*Note: A dated sales docket WILL be required for warranty service.

The original consumer-purchaser will be responsible for all shipping charges for parts replaced under the terms of this limited warranty.

Manufacturer requires proof of your date of purchase. Therefore, you should retain your sales slip or invoice. Registering your product is not a substitute for proof of purchase and the manufacturer is not responsible for or required to retain proof of purchase records.

This manufacturer's warranty applies to the functionality of the product ONLY and does not cover cosmetic issues such as scratches, dents, corruptions or discoloring by heat, abrasive and chemical cleaners or any tools used in the assembly or installation of the appliance, surface rust, or the discoloration of stainless steel surfaces. **RUST is not considered a manufacturing or materials defect.**

This manufacturer's warranty will not reimburse you for the cost of any inconvenience, food, personal injury or property damage.

ITEMS EXCLUDED FROM THIS MANUFACTURER'S WARRANTY:

1. Shipping cost, standard or expedited, for warranty and replacement parts
2. Service calls to your home.
3. Repairs when your product is used for other than normal, single-family household or residential use.
4. Damage, failures, or operating difficulties resulting from accident, alteration, careless handling, misuse, abuse, fire, flood, acts of God, improper installation or maintenance, installation not in accordance with electrical or plumbing codes, or use of products not approved by the manufacturer.
5. Food or fuel loss due to improper use or non-warranted failures.
6. Pickup and delivery of your product.
7. Repairs to parts or systems resulting from unauthorized modifications made to the product.
8. The removal and/or reinstallation of your product.

DISCLAIMER OF IMPLIED WARRANTIES and LIMITATION OF REMEDIES

Repair or replacement of defective parts is your exclusive remedy under the terms of this limited warranty. In the event of parts availability issues, the manufacturer reserves the right to substitute like or similar parts that are equally functional.

Manufacturer will not be responsible for failure or damage resulting from acts of God, improper care and maintenance, grease fire, accident, alteration, replacement of parts by anyone other than Manufacturer, misuse, transportation, commercial use, abuse, hostile environments (inclement weather, acts of nature, animal tampering), improper installation or installation not in accordance with local codes or printed manufacturer instructions.

THIS MANUFACTURER'S WARRANTY IS THE SOLE EXPRESS WARRANTY GIVEN BY THE MANUFACTURER. NO PRODUCT PERFORMANCE SPECIFICATION OR DESCRIPTION WHEREVER APPEARING IS WARRANTED BY MANUFACTURER EXCEPT TO THE EXTENT SET FORTH IN THIS LIMITED WARRANTY.

Neither dealers nor the retail establishment selling this product has any authority to make any additional warranties or to promise remedies in addition to or inconsistent with those stated above. Manufacturer's **maximum liability**, in any event, shall not exceed the purchase price of the product paid by the original consumer.

If you wish to obtain performance of any obligation under this limited warranty, you should write to:

OZtrail Leisure Products
P.O. Box 1
Sumner Park, QLD 4074
Business Address: 45 Limestone St, Darra, Queensland, 4076
Phone Number: (07) 3279 1800
Email: warranty@oztrail.com.au

Consumer returns will not be accepted unless a valid Return Authorization is first acquired. Authorized returns are clearly marked on the outside of the package with an RA number and the package is shipped freight/postage pre-paid. Consumer returns that do not meet these standards will be refused.

Our goods come with guarantees that cannot be excluded under the Australian Consumer Law. You are entitled to a replacement or refund for a major failure and for compensation for any other reasonably foreseeable loss or damage. You are entitled to have the goods repaired or replaced if the goods fail to be of acceptable quality and the failure does not amount to a major failure.

PARTS LIST

Key	Qty	Description
A	1	FIREBOX
B	1	LEFT, GREASE TRAY RAIL
C	1	RIGHT, GREASE TRAY RAIL
D	1	BURNER, W/ ELECTRODE
E	1	HEAT TENT
F	1	HEAT SHIELD
G	2	LATCH ASSEMBLY
H	1	WIND BARRIER
I	1	GREASE TRAY
J	1	LEG, LEFT
K	1	LEG, RIGHT
L	1	COOKING GRATE
M	1	LID
N	1	HANDLE
O	1	LOGO PLATE
P	1	TEMPERATURE GAUGE
Q	1	LID HINGE HARDWARE
R	1	IGNITOR
S	1	GROUND CONNECTOR
T	1	REGULATOR

NOT Pictured

...	1	GRATE CLEANING TOOL
...	1	PRODUCT GUIDE, AUSTRALIAN
...	1	BARBECUING GUIDE, ENGLISH
...	1	LIGHTING INSTRUCTION LABEL, ENGLISH
...	1	TOTE BAG

PARTS DIAGRAM

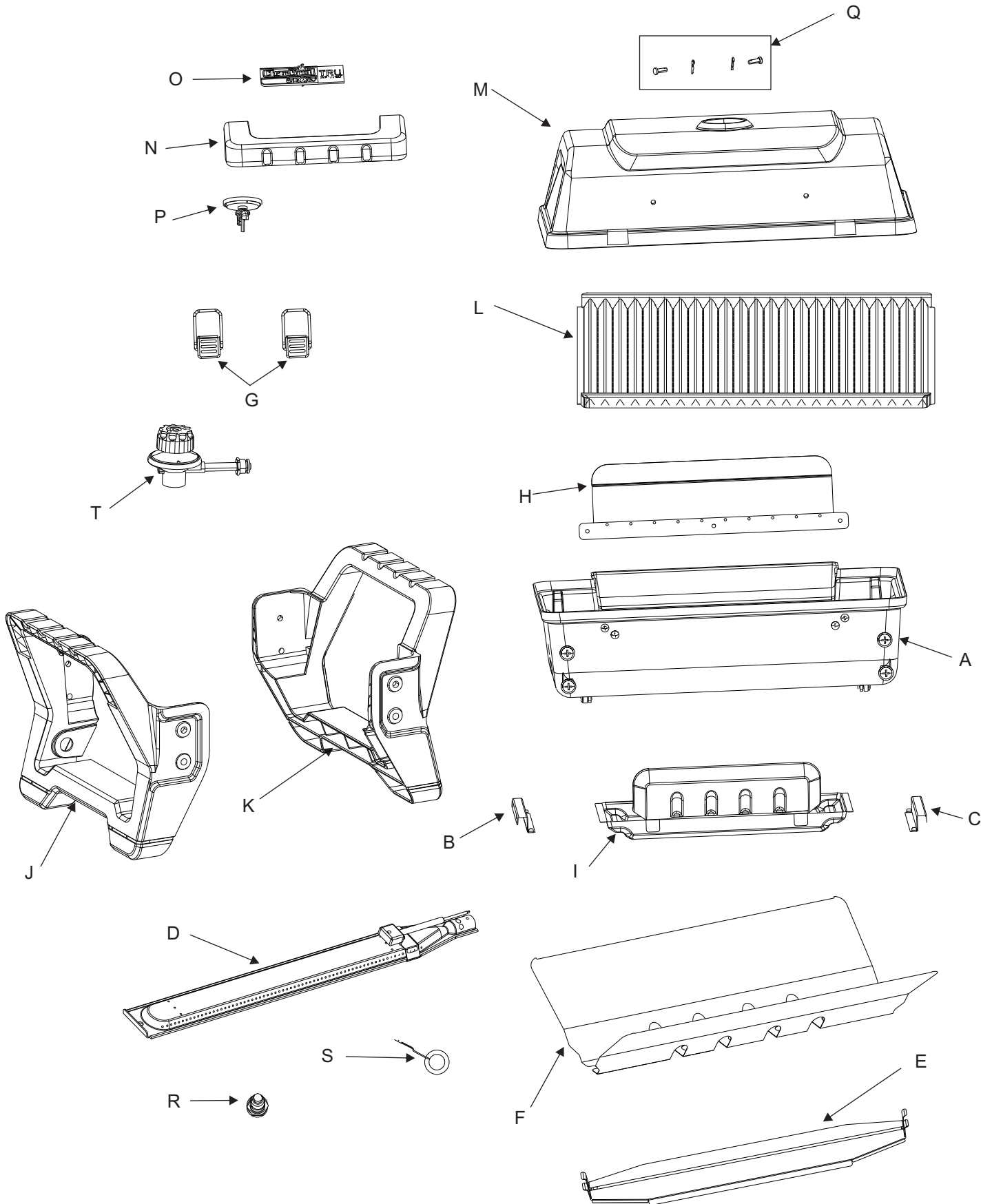

PARTS ASSEMBLY

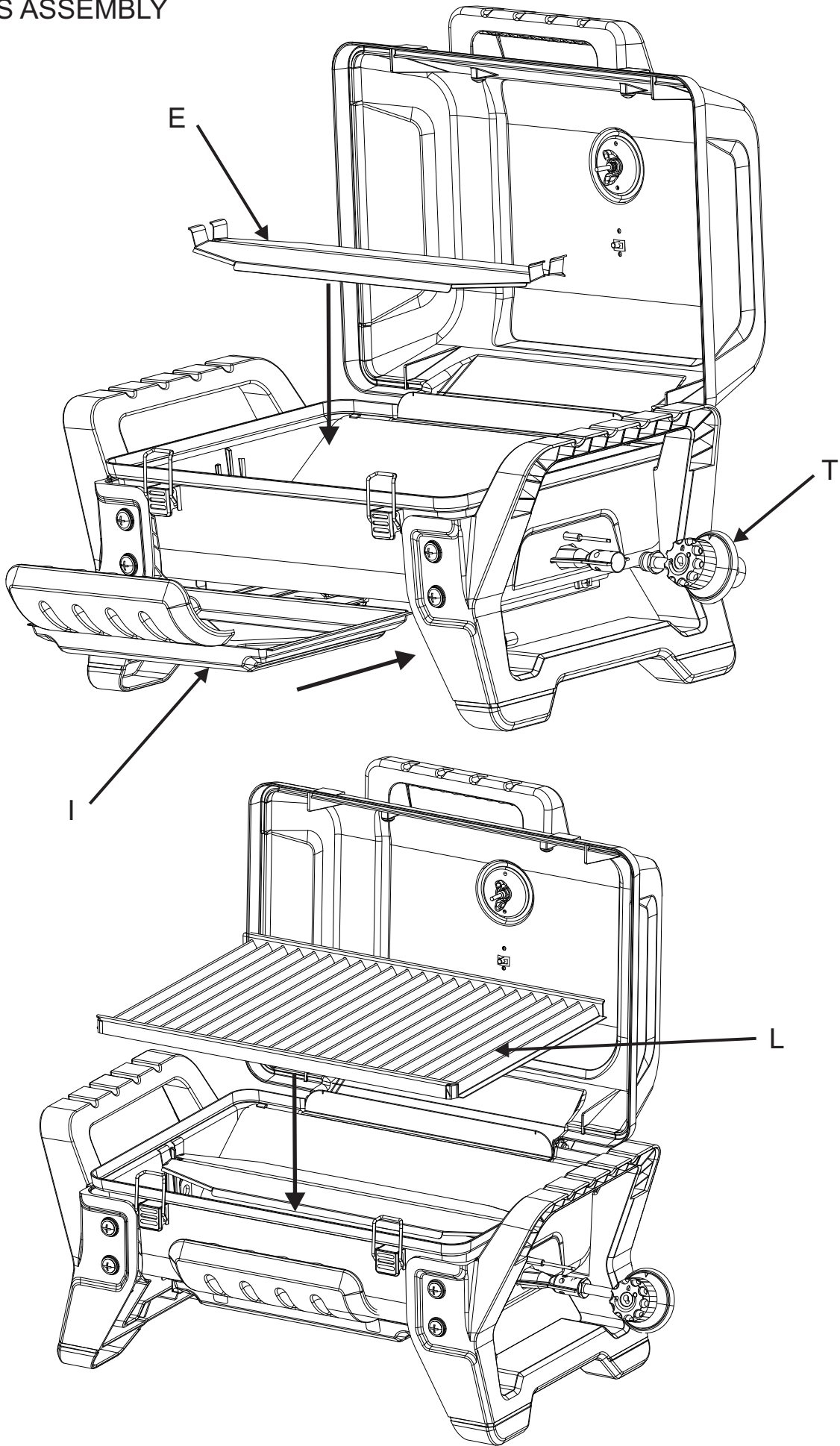

DANGER: If a gas leak cannot be stopped, or a fire occurs due to gas leakage, call the fire department.

Emergencies	Possible Cause	Prevention/Solution
Gas leaking from LP container.	<ul style="list-style-type: none"> •Mechanical failure due to rusting or mishandling. 	<ul style="list-style-type: none"> •Replace LP container.
Gas leaking between LP container and regulator control valve connection.	<ul style="list-style-type: none"> •Improper installation, connection not tight, failure of rubber seal. 	<ul style="list-style-type: none"> • Remove regulator control valve from container and visually inspect for damage. See LP Container Leak Test and Connecting Regulator control valve to the LP Container.
Fire coming through at burner/regulator control valve connection	<ul style="list-style-type: none"> •Fire in burner tube section of burner due to blockage. 	<ul style="list-style-type: none"> •Turn off control knob. Leave lid open to allow flames to die down. After fire is out and barbecue is cold, remove burner and inspect for spider nests or rust. See Natural Hazard and Cleaning the Burner Assembly pages.
Grease fire or continuous excessive flames above cooking surface.	<ul style="list-style-type: none"> •Too much grease buildup in firebox. 	<ul style="list-style-type: none"> •Turn off control knob and LP container valve. Leave lid open to allow flames to die down. After cooling, clean food particles and excess grease from inside firebox area, grease cup, and other surfaces.

Troubleshooting

Problem	Possible Cause	Prevention/Solution
<p>Burner(s) will not light using ignitor.</p> <p><i>Continued on next page.</i></p>	<p>GAS ISSUES:</p> <ul style="list-style-type: none"> •Burner not engaged with regulator control valve. •Obstruction in burner. •No gas flow. •Regulator Control Valve and LP container valve not fully connected. •Regulator Control Valve knob does NOT pop up in the OFF position. •Regulator Control Valve knob does NOT stay down in ON positions. <p>ELECTRICAL ISSUES:</p> <ul style="list-style-type: none"> •Electrode cracked or broken; “sparks at crack.” •Electrode and burner are wet •Wire and/or electrode covered with cooking residue. •Wires are loose or disconnected. •Wires are shorting (sparking) between ignitor and electrode. 	<ul style="list-style-type: none"> •Make sure regulator control valve is positioned inside of burner tube. •Ensure burner tube is not obstructed with spider webs or other matter. See cleaning section of Use and Care. •Make sure LP container is not empty. •Remove LP container. Clean threads on LP container and regulator control valve. •Replace regulator control valve. •Replace regulator control valve. •Replace electrode(s). •Wipe dry with a cloth. •Clean wire and/or electrode with rubbing alcohol and clean swab. •Reconnect wires or replace electrode/wire assembly. •Replace ignitor wire/electrode assembly.

REV00

Troubleshooting (continued)

Problem	Possible Cause	Prevention/Solution
Burner(s) will not light using ignitor.	<ul style="list-style-type: none"> •Push-button sticks at bottom. •Sparking between ignitor and electrode. 	<ul style="list-style-type: none"> •Replace ignitor. •Inspect wire insulation and proper connection. Replace ignitor wire / electrode assembly if insulation is broken.
Burner(s) will not match light.	<ul style="list-style-type: none"> •See “GAS ISSUES:” on previous page. •Match will not reach using match holder. •Improper method of match-lighting. 	<ul style="list-style-type: none"> •Use long-stem match (fireplace match). •See “Match-Lighting” section of Use and Care.
Low flame, drop in gas flow.	<ul style="list-style-type: none"> •Out of gas. 	<ul style="list-style-type: none"> •Check for gas in LP container.
Flames blow out.	<ul style="list-style-type: none"> •High or gusting winds. •Low on LP gas. 	<ul style="list-style-type: none"> •Turn front of barbecue to face wind or increase flame height. •Replace LP container.
Flare-up.	<ul style="list-style-type: none"> •Grease buildup. •Excessive fat in meat. •Excessive cooking temperature. 	<ul style="list-style-type: none"> •Clean heat tent / burner and inside of barbecue/firebox. •Trim fat from meat before barbecuing. •Adjust (lower) temperature accordingly.
Persistent grease fire.	<ul style="list-style-type: none"> •Grease trapped by food buildup in firebox 	<ul style="list-style-type: none"> •Turn regulator control knob to OFF. Turn gas off at LP container. Leave lid in closed position and let fire burn out. After barbecue cools, remove and clean all parts.
Flashback... (fire in burner tube(s)).	<ul style="list-style-type: none"> •Burner and/or burner tubes are blocked. 	<ul style="list-style-type: none"> •Turn knob to OFF. Clean burner and/or burner tubes. See burner cleaning section of Use and Care.

NOTES