

Use & Care MANUAL



5 SERIES

Professional Built-In Electric Warming Drawers
(Indoor and Outdoor Models)

*VEWD527 / CVEWD527 / VEWD530 / CVEWD530
VEWDO530 / CVEWDO530 / VEWDO536 / CVEWDO536*

Congratulations

Congratulations and welcome an elite world of ownership. We hope you will enjoy and appreciate the care and attention we have put into every detail of your warming drawer.

Your product is designed to offer years of reliable service. This Use and Care Manual will provide you with the information you need to become familiar with your drawer's care and operation.

Your complete satisfaction is our ultimate goal. If you have any questions or comments about this product, please contact our Consumer Support Center at 1-888-(845-4641).

We appreciate your choice of our product and hope that you will again select our products for your other major appliance needs.

For more information about the complete and growing selection of Viking products, visit us online at vikingrange.com in the US or brigade.ca in Canada.

Table of Contents

Getting Started

Warnings and Important Safety Information	3
Before Using Warming Drawer	5
Drawer Features	5

Operation

Warming Element	6
To use Moist Heat function	6
To use Dry Heat Function	6
Drawer Indicator Light	6
Optional Accessories for Moist or Dry Heat	6
Temperature Control Settings	7
Proofing	7
Warming Plates	7
Power "ON" Light	7
Moisture Selector Control	7
Suggested Heat Settings	8

Product Care

Cleaning and Maintenance	9
Troubleshooting	10
Service Information	10
Warranty	11

Warnings

Warning and Important Safety Instructions appearing in this manual are not meant to cover all possible conditions and situations that may occur. Common sense, caution, and care must be exercised when installing, maintaining, or operating the appliance.

ALWAYS contact the manufacturer about problems or conditions you do not understand.

Recognize Safety Symbols, Words, Labels

⚠ DANGER
Hazards or unsafe practices which WILL result in severe personal injury or death
⚠ WARNING
Hazards or unsafe practices which COULD result in death or severe personal injury
⚠ CAUTION
Hazards or unsafe practices which COULD result in minor personal injury. All safety messages will identify the hazard, tell you how to reduce the chance of injury, and tell you what can happen if the instructions are not followed.

Read and follow all instructions before using this appliance to prevent the potential risk of fire, electric shock, personal injury or damage to the appliance as a result of improper usage of the appliance. Use appliance only for its intended purpose as described in this manual.

To ensure proper and safe operation: Appliance must be properly installed and grounded by a qualified technician. **DO NOT** attempt to adjust, repair, service, or replace any part of your appliance unless it is specifically recommended in this manual. All other servicing should be referred to a qualified servicer.

⚠ WARNING
 To avoid risk of property damage, personal injury or death; follow information in this manual exactly to prevent a fire or explosion. DO NOT store or use gasoline or other flammable vapors and liquids in the vicinity of this or any appliance.

⚠ WARNING
NEVER use this appliance as a space heater to heat or warm the room. Doing so may result in carbon monoxide poisoning and overheating of the drawer.

⚠ CAUTION
DO NOT use plastic wrap to cover foods placed in the drawer, nor to keep foods warm that are wrapped or placed in plastic containers for heating. Plastics can melt onto the drawer if they are in direct contact. If melted onto the drawer, they can be very difficult to remove.

⚠ WARNING
If the information in this manual is not followed exactly, a fire or explosion may result causing property damage, personal injury or death.

⚠ CAUTION
DO NOT use any cleaning agent with chlorine or chlorine compounds on stainless steel finish. Chlorine and chlorine compounds are corrosive to stainless steel.

⚠ WARNING
To avoid sickness and food waste, do not allow defrosted food to remain in the drawer for more than two hours.

⚠ WARNING
NEVER cover any slots, holes or passages in the drawer or cover an entire rack with materials such as aluminum foil. Doing so blocks air flow through the oven and may cause carbon monoxide poisoning. Aluminum foil linings may also trap heat, causing a fire hazard.

⚠ WARNING
 BURN OR ELECTRICAL SHOCK HAZARD Make sure all controls are OFF and drawer is COOL before cleaning. Failure to do so can result in burns or electrical shock.

Warnings

⚠ WARNING

Make sure that incoming voltage is the same as unit rating. An electric rating plate specifying voltage, hertz, wattage, amps, and phase is attached to the product. Wiring the warming drawer with more voltage than it is rated for may cause severe damage to the thermostat, element, and other components. Wiring the warming drawer with less voltage than it is rated for may cause significant decrease in performance.

⚠ WARNING

To reduce the risk of fire, electric shock, or injury to persons, installation work and electrical wiring must be done by qualified people in accordance with all applicable codes and standards, including fire-rated conditions.

⚠ WARNING

For outdoor installation, installer must install a ground fault interrupt.

⚠ WARNING



FIRE AND ELECTRICAL SHOCK HAZARD

To reduce the risk of electric shock and fire, **DO NOT** use a flexible power-supply cord with this appliance.

To Prevent Fire or Smoke Damage

- Be sure all packing materials are removed from the appliance before operating it.
- Keep area around appliance clear and free from combustible materials, gasoline, and other flammable vapors and materials.
- Many aerosol-type spray cans are **EXPLOSIVE** when exposed to heat and may be highly flammable. Avoid their use or storage near an appliance.
- Many plastics are vulnerable to heat. Keep plastics away from parts of the appliance that may become warm or hot. **DO NOT** leave plastic items in the drawer as they may melt or soften if left too close to a heating element.
- Combustible items (paper, plastic, etc.) may ignite and metallic items may become hot and cause burns. **DO NOT** pour spirits over hot foods.

About your Appliance

- **DO NOT** touch the heating elements or interior surface of the drawer while it is in use. Use handles or knobs.
- **DO NOT** store flammable materials in drawer.

Heating Elements

- Use only dry potholders. If moist or damp potholders are used, steam from potholders could cause a steam burn. **DO NOT** let potholders touch hot heating elements located under the drawer. **DO NOT** use a towel or bulky cloths in place of potholders.
- Use care when opening the drawer. Let hot air or steam escape (open vent) before removing or replacing food.
- **DO NOT** place food in unopened containers in the drawer. Pressure could build up and cause the container to burst.
- **NEVER** use the appliance for other than intended use.
- **DO NOT** use water on grease fires. Smother fire or flame or use dry chemical or foam-type extinguisher.
- **DO NOT** use aluminum foil to line the drawer. It is an excellent heat insulator and will trap heat beneath it. This will upset the performance and can damage the interior finish.
- Always place warming racks in desired position while drawer is cool.
- Keep drawer closed when not in use.
- **DO NOT** place items exposed to cooking oils in your warming drawer. Items contaminated with cooking oils may contribute to a chemical reaction that could cause a load to catch fire.
- **DO NOT** install or store indoor models where they will be exposed to the weather.

Before Using Drawer

All products are wiped clean with solvents at the factory to remove any visible signs of dirt, oil, and grease which may have remained from the manufacturing process. Before using, clean the drawer thoroughly with hot, soapy water. There may be some burn off and odors on first use of the appliance—this is normal.

Drawer Features

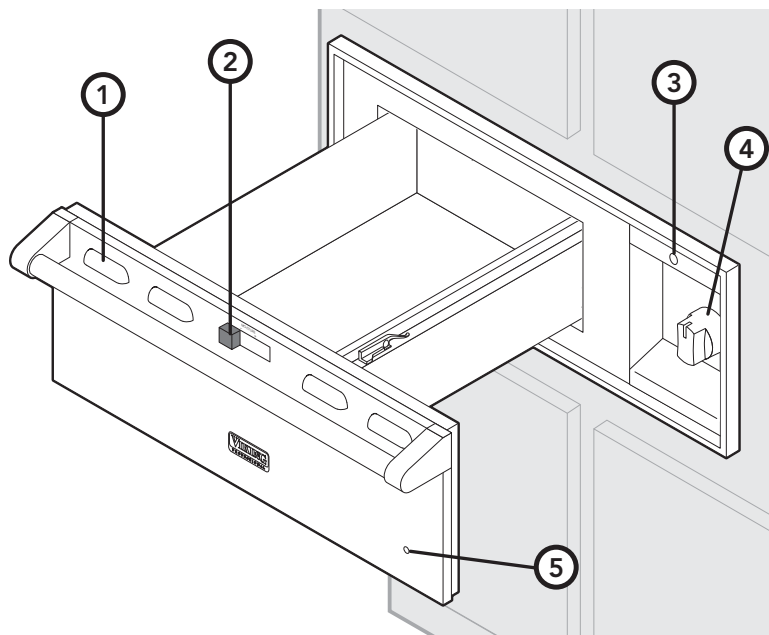

1. Vents
2. Moisture Selector Control
3. ON/OFF Indicator Light
4. Temperature Control Knob
5. Drawer Indicator Light

Operation

Your warming drawer works in two ways:

1. Seals moisture within the drawer to keep food moist.
2. Allows moisture to escape and keep food crisp.

The purpose of the warming drawer is to keep hot, cooked foods at serving temperature. Always start with hot food; cold food cannot be heated in the warming drawer.

Warming Element

Turn the control knob clockwise to the desired setting. The element will cycle on and off to maintain the desired heat setting. When finished turn the control to "OFF."

Note: The majority of foods are held at a medium setting to maintain a serving temperature.

To use Moist Heat function

1. Place low racks in warming drawer.
2. Fill the moisture cup with 1/2 cup water and place the cup in the rear center opening of the low rack.
3. Place the food or cookware with food directly on the rack.
4. Turn the control knob to the desired heat setting and close the drawer.
5. Slide the moisture control to the right to close the vents which seals in the heat.

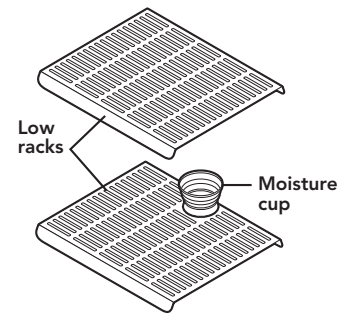

Use moist heat when proofing breads and keeping foods moist such as casseroles, meats, and sauces.

To use Dry Heat Function

1. Place the food or cookware with food in the empty drawer pan.
2. Turn the control knob to the desired heat setting and close the drawer.
3. Slide the moisture control to the left to open the vents which allows the moist heat to escape.

Use dry heat when warming dishes and keeping foods crispy such as pies, breads and fried foods.

Drawer Indicator Light

The drawer indicator light is located on the front panel of the drawer. The drawer indicator light will glow red when the drawer element is heated. The light will cycle on and off as the temperature is maintained.

Optional Accessories for Moist or Dry Heat

Pans/Lids (PAN-VEWD) - This warming drawer is designed to accommodate standard size pan inserts. The optional pan/lid set can be purchase through our online store at vikingrange.com and consists of:

- 1) one 4" D. x 12" L. x 10½" W. pan/lid
- 2) two 4" D. x 12" L. x 7" W. pans/lids
- 3) two 2½" D. x 12" L. x 7" W. pans/lids

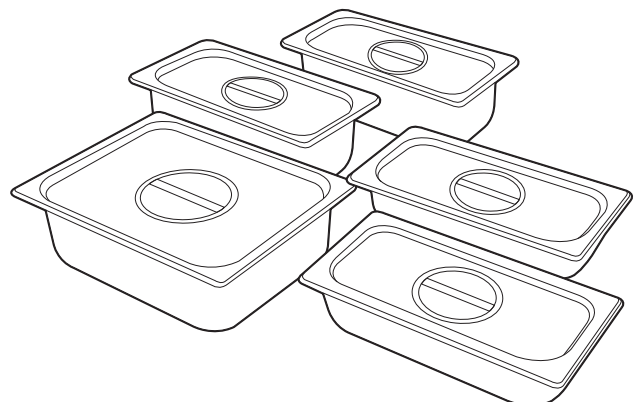

Operation

Temperature Control Settings

The knob is used to select the temperature of the drawer and is located on the right side of the control panel. The "1" setting represents low, "2" represents medium, and "3" represents high. The majority of foods are held at a medium setting to maintain a serving temperature. However, your own preference may be for hotter foods.

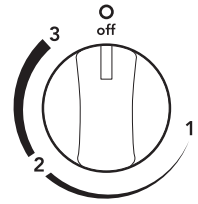

To keep several types of food hot for serving, key the temperature setting for the meat. For example, to hold rare roast beef, select a lower setting, cover the other foods that otherwise would be kept at a higher setting.

Repeated opening of the drawer allows the hot air to escape and the food to cool. The drawer should not be opened unless adding or removing food.

Proofing

Yeast dough can be proofed in the warming drawer. Place the dough in a bowl. Place the bowl on the low rack in the drawer. Fill the moisture cup half full with water and place in the opening in the rear center of the low rack. Turn the temperature control to the lowest setting to facilitate the fermentation time. A towel should be placed over the dough to minimize surface drying. The dough should remain in the warming drawer until it has doubled in size and a slight depression remains when the surface is touched gently with a finger.

Warming Plates

To warm serving bowls and plates, place temperature control on a low setting. Place the empty dishes on the low rack to raise them off the bottom of the drawer. If you want hotter dishes or want to heat fine china, please check with the manufacturer of the dishes for their maximum heat tolerance.

Power "ON" Light

The power "ON" light is located above the temperature control knob on Custom models and below the temperature control knob on Designer models. It turns on when the control knob is set and cycles on and off with the heating element as temperature is maintained.

Moisture Selector Control

The moisture selector control is located at the top of the warming drawer. To keep foods moist, move the handle to the right. This closes the vents and seals the moisture inside the drawer. For crisp foods, move the handle to the left. This opens the vents and allows the moisture to escape. The moisture selector can be placed in any position between "-" (open for less moisture) and "+" (closed to retain moisture) to maintain any degree of moisture.

In the closed position, the drawer is completely sealed which keeps the hot foods moist and soft. In this setting, condensation may be noticed around the inside edge of the drawer. If the drawer is not full, there may be some drying on the surface of the food. If this happens, simply cover the food with a lid or aluminum foil.

When in the open position, the drawer is vented, which lets moisture escape. This dry heat keeps the foods exterior dry and crisp. With the vents open, it is normal for moisture to collect on surfaces above the warming drawer. Simply wipe up the moisture with a dry cloth.

⚠ CAUTION

DO NOT use plastic wrap to cover foods placed in the drawer, nor to keep foods warm that are wrapped or placed in plastic containers for heating. Plastics can melt onto the drawer if they are in direct contact. If melted onto the drawer, they can be very difficult to remove.

Operation

Suggested Heat Settings

The information below is given as a guide only. You may need to vary the heat settings to suit your personal requirements.

Food	Temperature Settings	Moisture Settings
Bacon	2 – 3	–
Beef, medium and well done	2	+
Beef, rare	1 – 2	+
Bread, hard roll	2	–
Bread, soft rolls	2	–
Casseroles	2	+
Cooked cereal	2	+
Dough, proofing	1	+
Eggs	2	+
Fish, seafood (baked)	2	+
Fried foods	3	–
Fruit	2	+
Gravy, creamed sauces	2	+
Ham	2	+
Pancakes, waffles	2 – 3	+
Pies, one crust	2	+
Pies, two crust	2	–
Pizza	2 – 3	halfway
Pork	2	+
Potatoes, baked	3	halfway
Potatoes, mashed	2	+
Poultry	2 – 3	+
Vegetables	2	–

Cleaning and Maintenance

Any piece of equipment works better and lasts longer when maintained properly and kept clean. Cooking equipment is no exception. Your warming drawer must be kept clean and maintained properly. Make sure all controls are in the "OFF" position.

1. Allow warming drawer to cool completely.
2. It is important to keep the slide rails clear and free from debris. Periodic cleaning of slide rails and other adjoining parts is necessary to assure smooth drawer operation.
3. If needed, the warming drawer pan support can be removed for cleaning. Pull the warming drawer out until fully extended. Slide finger along right and left side rail until you reach hand latches (located at the front of rails). Pull up on both right and left latches. Pull drawer support completely out.
4. When installed outdoors, annually inspect the silicon seal around the flange of the appliance. Re-seal as needed to assure this seam is waterproof.

Control Knobs

MAKE SURE ALL CONTROL KNOBS POINT TO THE "OFF" POSITION BEFORE REMOVING. Pull the knobs straight off. Wash in detergent and warm water. Dry completely and replace by pushing firmly onto stem.

Stainless Steel Parts

All stainless steel body parts should be wiped regularly with hot soapy water at the end of each cooling period and with a liquid cleaner designed for that material when soapy water will not do the job. **DO NOT** use steel wool, abrasive cloths, cleansers, or powders. If necessary, scrape stainless steel to remove encrusted materials, soak the area with hot towels to loosen the material, then use a wooden or nylon spatula or scraper. **DO NOT** use a metal knife, spatula, or any other metal tool to scrape stainless steel. **DO NOT** permit citrus or tomato juice to remain on stainless steel surface, as citric acid will permanently discolor stainless steel. Wipe up any spills immediately.

⚠ CAUTION

DO NOT use any cleaning agent with chlorine or chlorine compounds on stainless steel finish. Chlorine and chlorine compounds are corrosive to stainless steel.

Cleaning Chart

Material/Problem	Cleaning Products	Directions
Stainless steel/ Enamels	Mild cleaners	Sponge with cloth, then rinse with clear water and wipe dry. Satisfactory for use on all finishes.
Hard water spots and scales	Vinegar and water	Swab or wipe with cloth. Rinse with clear water and dry. Satisfactory for use on all finishes.
	Soft, non-abrasive cleaners	Apply with damp sponge or cloth. Satisfactory for use on all finishes if rubbing is light. Rub in direction of the polish lines.
Plastic (Control knob)	Soap and water	Pull off knob. Wash but DO NOT soak. Rinse with water, dry and replace on control.



Troubleshooting

Problem	Possible Cause and/or Remedy
Warming drawer will not function.	Drawer is not connected to electrical power: Have electrician check power circuit breaker, wiring, and fuses.

Service Information

If service is required, call your authorized service agency.

Have the following information readily available.

- Model number
- Serial number
- Date purchased
- Name of dealer from whom purchased

Clearly describe the problem that you are having. If you are unable to obtain the name of an authorized service agency, or if you continue to have service problems, contact Viking Range, LLC at 1-888-(845-4641), or write to:

**VIKING RANGE, LLC
PREFERRED SERVICE
111 Front Street
Greenwood, Mississippi 38930 USA**

Record the information indicated below. You will need it if service is ever required. The model and serial number for your warming drawer Rating/Serial plate is located on the left, rear side.

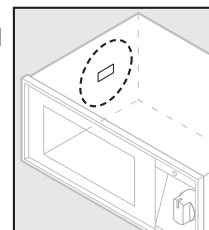

Model no. _____ Serial no. _____

Date of purchase _____ Date installed _____

Dealer's name _____

Address _____

If service requires installation of parts, use only authorized parts to insure protection under the warranty.

Keep this manual for future reference.

Warranty

PROFESSIONAL CUSTOM BUILT-IN ELECTRIC WARMING DRAWER WARRANTY

TWO YEAR FULL WARRANTY (Indoor Models Only)

Built-in indoor electric warming drawers and all of their component parts, **except as detailed below***†, are warranted to be free from defective materials or workmanship in normal residential use for a period of two (2) years from the date of original retail purchase or closing date for new construction, whichever period is longer. Viking Range, LLC, warrantor, agrees to repair or replace, at its option, any part which fails or is found to be defective during the warranty period.

TWO YEAR FULL WARRANTY (Outdoor Models Only)

Built-in outdoor electric warming drawers and all of their component parts, **except as detailed below***†, are warranted to be free from defective materials or workmanship in normal residential use for a period of two (2) years from the date of original retail purchase or closing date for new construction, whichever period is longer. Viking Range, LLC, warrantor, agrees to repair or replace, at its option, any part which fails or is found to be defective during the warranty period.

***FULL NINETY (90) DAY COSMETIC WARRANTY:** Product is warranted to be free from cosmetic defects in materials or workmanship (such as scratches on stainless steel, paint/porcelain blemishes, etc.) for a period of ninety (90) days from the date of original retail purchase or closing date for new construction, whichever period is longer. Any defects must be reported to the selling dealer within ninety (90) days from date of original retail purchase. Viking Range, LLC uses high quality processes and materials available to produce all color finishes. However, slight color variation may be noticed because of the inherent differences in painted parts and porcelain parts as well as differences in kitchen lighting, product locations, and other factors. Therefore, this warranty does not apply to color variation attributable to such factors.

†FULL NINETY (90) DAY WARRANTY IN "RESIDENTIAL PLUS" APPLICATIONS: This full warranty applies to applications where use of the product extends beyond normal residential use, but the warranty period for products used in such applications is ninety (90) days. Examples of applications covered by this warranty are bed and breakfasts, fire stations, private clubs, churches, yachts, etc. Under this "Residential Plus" warranty, the product, its components and accessories are warranted to be free from defective material or workmanship for a period of ninety (90) days from the date of original retail purchase. This warranty excludes use of the product in all commercial locations such as restaurants, food service locations and institutional food service locations.

FIVE YEAR LIMITED WARRANTY

Any electric element which fails due to defective materials or workmanship in normal household use during the third through fifth year from the date of original purchase will be repaired or replaced, free of charge for the part itself, with the owner paying all other costs, including labor.

TERMS AND CONDITIONS

This warranty extends to the original purchaser of the product warranted hereunder and to each transferee owner of the product during the term of the warranty and applies to products purchased and located in the United States, Canada, Mexico or the Caribbean (excluding Cuba, Dominican Republic and Haiti). Products must be purchased in the country where service is requested. If the product or one of its component parts contains a defect or malfunction during the full warranty period after a reasonable number of attempts by the warrantor to remedy the defect or malfunction, the owner is entitled to either a refund or replacement of the product or its component part or parts. Replacement of a component part includes its free installation, except as specified under the limited warranty. Under the terms of this warranty, service must be performed by a factory authorized Viking Range, LLC service agent or representative. Service will be provided during normal business hours, and labor performed at overtime or premium rates shall not be covered by this warranty.

Owner shall be responsible for proper installation, providing reasonable and necessary maintenance, providing proof of purchase upon request, and making the appliance reasonably accessible for service. The return of the Owner Registration Card is not a condition of warranty coverage. You should, however, return the Owner Registration Card so that Viking Range, LLC can contact you should any question of safety arise which could affect you.

This warranty gives you specific legal rights, and you may also have other rights which may vary from jurisdiction to jurisdiction.

WHAT IS NOT COVERED BY THIS WARRANTY: This warranty shall not apply to damage resulting from abuse, failure to provide reasonable and necessary maintenance, accident, delivery, negligence, natural disaster, loss of electrical power to the product for any reason, alteration, outdoor use, improper installation, improper operation, or repair or service of the product by anyone other than an authorized Viking Range, LLC service agency or representative. This warranty does not apply to commercial usage.

LIMITATION OF REMEDIES AND DURATION OF IMPLIED WARRANTY

OWNER'S SOLE AND EXCLUSIVE REMEDY FOR A CLAIM OF ANY KIND WITH RESPECT TO THIS PRODUCT SHALL BE THE REMEDIES SET FORTH ABOVE. VIKING RANGE, LLC IS NOT RESPONSIBLE FOR CONSEQUENTIAL OR INCIDENTAL DAMAGE, INCLUDING BUT NOT LIMITED TO FOOD OR MEDICINE LOSS, DUE TO PRODUCT FAILURE, WHETHER ARISING OUT OF BREACH OF WARRANTY, BREACH OF CONTRACT OR OTHERWISE. Some jurisdictions do not allow the exclusion or limitation of incidental or consequential damages, so the above limitation or exclusions may not apply to you. Any implied warranties of merchantability or fitness for a particular purpose applicable to this product are limited in duration to the period of coverage of the applicable express written limited warranties set forth above. Some states do not allow limitations on how long an implied warranty lasts, so the above limitation may not apply to you.

WARRANTY SERVICE

To obtain warranty service, contact an authorized Viking Range, LLC service agent, or Viking Range, LLC, 111 Front Street, Greenwood, Mississippi 38930, (888) 845-4641. Provide model and serial number and date of original purchase or closing date for a new construction. For the name of your nearest authorized Viking Range, LLC service agency, call Viking Range, LLC or visit our web site at vikingrange.com

IMPORTANT: Retain proof of original purchase to establish warranty period.

Specifications subject to change without notice.

Viking Range, LLC
111 Front Street
Greenwood, Mississippi 38930 USA
(662) 455-1200

For product information,
call 1-888-(845-4641)
or our web site at vikingrange.com in the US
or brigade.ca in Canada