

SEARS

OWNER'S MANUAL

**MODEL NO.
536.884811**

Caution:
Read and Follow
all Safety Rules
and Instructions
Before Operating
This Equipment

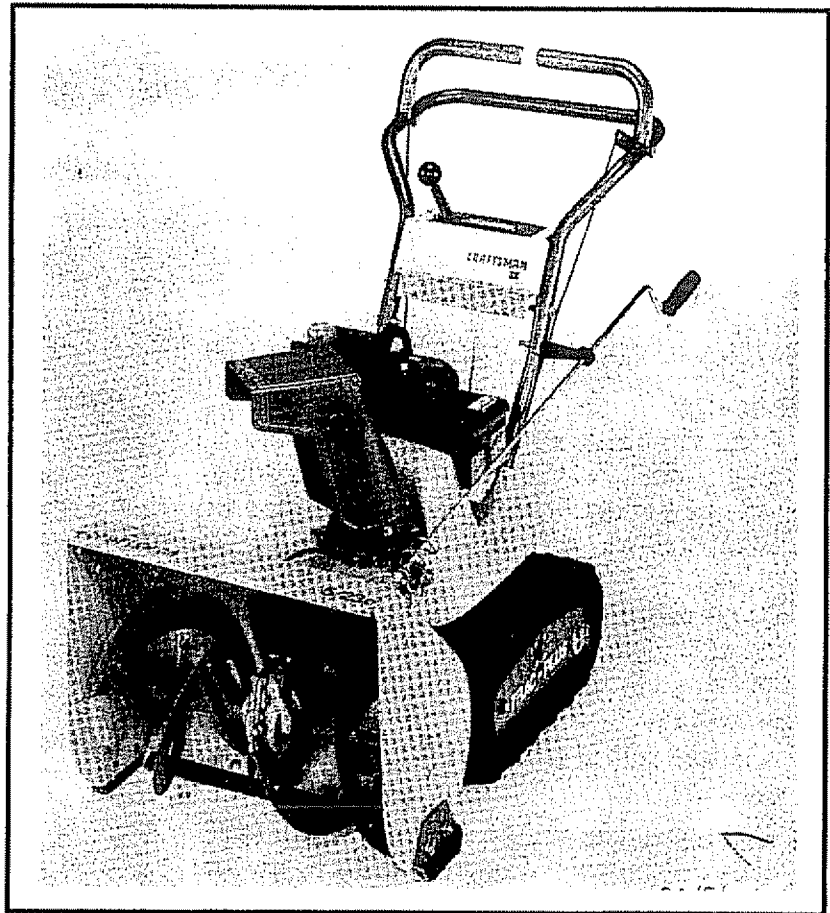

CRAFTSMAN®

**5 HORSEPOWER
23" DUAL STAGE
TRAC-PLUS
OPTIONAL ELECTRIC START
SNOW THROWER**

- Assembly
- Operation
- Maintenance
- Service and Adjustments
- Repair Parts

SEARS, ROEBUCK AND Co., Chicago, IL. 60684 U.S.A.

SAFETY RULES



CAUTION: ALWAYS DISCONNECT SPARK PLUG WIRE AND PLACE WIRE WHERE IT CANNOT CONTACT SPARK PLUG TO PREVENT ACCIDENTAL STARTING WHEN SETTING-UP, TRANSPORTING, ADJUSTING OR MAKING REPAIRS.



IMPORTANT

SAFETY STANDARDS REQUIRE OPERATOR PRESENCE CONTROLS TO MINIMIZE THE RISK OF INJURY. YOUR SNOW THROWER IS EQUIPPED WITH SUCH CONTROLS. DO NOT ATTEMPT TO DEFEAT THE FUNCTION OF THE OPERATOR PRESENCE CONTROL UNDER ANY CIRCUMSTANCES.

BEFORE USE

- Read the owner's manual carefully. Be thoroughly familiar with the controls and the proper use of the snow thrower. Know how to stop the snow thrower and disengage the controls quickly.
- Do not operate the snow thrower without wearing adequate winter outer garments. Wear footwear that will improve footing on slippery surfaces.
- Keep the area of operation clear of all persons, particularly small children, and pets.
- Thoroughly inspect the area where the snow thrower is to be used and remove all doormats, sleds, boards, wires, and other foreign objects.
- Use extension cords and receptacles as specified by the manufacturer for all snow throwers with electric drive motors or electric starting motors.
- Use only attachments and accessories approved by the manufacturer of the snow thrower (such as tire chains, electric start kits, etc.)
- Never operate the snow thrower without good visibility or light. Always be sure of your footing, and keep a firm hold on the handles. Walk; never run.
- This snow thrower is for use on sidewalks, driveways, and other ground level surfaces. CAUTION should be exercised while using on steep sloping surfaces. DO NOT USE SNOW THROWER ON SURFACES ABOVE GROUND LEVEL such as roofs of residences, garages, porches or other such structures or buildings.
- Check shear bolts and other bolts at frequent intervals for proper tightness to be sure the snow thrower is in safe working condition.
- Disengage all clutches and shift into neutral before starting the engine.
- Adjust the snow thrower height to clear gravel or crushed rock surface.
- Let engine and snow thrower adjust to outdoor temperatures before starting to clear snow.

FUEL SAFETY

- Handle fuel with care; it is highly flammable.
- Use an approved fuel container.
- Check fuel supply before each use, allowing space for expansion as the heat of the engine and/or sun can cause fuel to expand.
- Fill fuel tank outdoors with extreme care. Never fill fuel tank indoors.
- Replace fuel tank cap securely and wipe up spilled fuel.
- Never remove fuel tank cap or add fuel to a running engine or hot engine.
- Never store fuel or snow thrower with fuel in the tank inside of a building where fumes may reach an open flame or spark.

OPERATING SAFETY

- Never allow children or young teenagers to operate the snow thrower and keep them away while it is operating. Never allow adults to operate the snow thrower without proper instruction. Do not carry passengers.
- Always wear safety glasses or eye shields during operation or while performing an adjustment or repair to protect eyes from foreign objects that may be thrown from the snow thrower.
- Exercise extreme caution when operating on or crossing gravel drives, walks, or roads. Stay alert for hidden hazards or traffic.
- Do not put hands or feet near or under rotating parts. Keep clear of the discharge opening at all times.
- Exercise caution to avoid slipping or falling, especially when operating in reverse.
- Do not clear snow across the face of slopes. Exercise caution when changing direction on slopes. Do not attempt to clear steep slopes.
- Never operate the snow thrower without proper guards, plates or other safety protective devices in place.

SAFETY RULES

- Never operate the snow thrower near glass enclosures, automobiles, window wells, drop-offs, and the like without proper adjustment of the snow discharge angle. Keep children and pets away.
- Never operate the snow thrower at high transport speeds on slippery surfaces. Look behind and use care when backing.
- Never direct discharge at bystanders or allow anyone in front of the snow thrower.
- Do not run the engine indoors, except when starting the engine and for transporting the snow thrower in or out of the building. Open the outside doors; exhaust fumes are dangerous (containing CARBON MONOXIDE, an ODORLESS and DEADLY GAS).
- Take all possible precautions when leaving the snow thrower unattended. Disengage the auger/impeller, shift to neutral, stop engine, and remove key.
- Do not overload the machine capacity by attempting to clear snow at too fast a rate.

SAFE STORAGE

- Always refer to owner's manual instructions for important details if the snow thrower is to be stored for an extended period.
- Disengage power to the auger/impeller when snow thrower is transported or not in use.
- Never store the snow thrower with fuel in the fuel tank inside a building where ignition sources are present such as hot water and space heaters, clothes dryers, and the like. Allow the engine to cool before storing in any enclosure.

REPAIR/ADJUSTMENTS SAFETY

- After striking a foreign object, stop the engine (motor), remove the wire from the spark plug, disconnect the cord on electric motors, thoroughly inspect the snow thrower for any damage, and repair the damage before restarting and operating the snow thrower.
- If the snow thrower should start to vibrate abnormally, stop the engine (motor) and check immediately for the cause. Vibration is generally a warning of trouble.
- Stop the engine (motor) whenever you leave the operating position, before unclogging the auger/impeller housing or discharge guide, and when making any repairs, adjustments, or inspections.
- When cleaning, repairing, or inspecting, make certain the auger/impeller and all moving parts have stopped. Disconnect the spark plug wire and keep the wire away from the plug to prevent accidental starting.
- Never attempt to make any adjustments while the engine is running (except when specifically recommended by manufacturer).
- Maintain or replace safety and instruction labels, as necessary.
- Run the snow thrower a few minutes after throwing snow to prevent freeze-up of the auger/impeller.

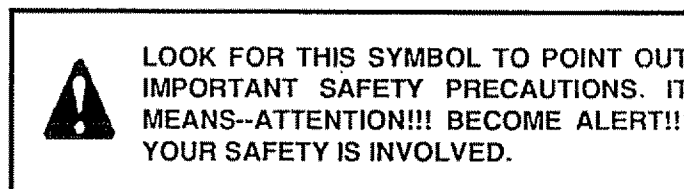

CONGRATULATIONS on your purchase of a Sears Craftsman Snow Thrower. It has been designed, engineered and manufactured to give you the best possible dependability and performance.

Should you experience any problem you cannot easily remedy, please contact your nearest Sears Service Center/Department. We have competent, well-trained technicians and the proper tools to service or repair this unit.

Please read and retain this manual. The instructions will enable you to assemble and maintain your snow thrower properly. Always observe the "SAFETY RULES."

<p>MODEL NUMBER 536.884811</p> <p>SERIAL NUMBER _____</p> <p>DATE OF PURCHASE _____</p> <p>THE MODEL AND SERIAL NUMBERS WILL BE FOUND ON A DECAL ATTACHED TO THE REAR OF THE SNOW THROWER HOUSING.</p> <p>YOU SHOULD RECORD BOTH SERIAL NUMBER AND DATE OF PURCHASE AND KEEP IN A SAFE PLACE FOR FUTURE REFERENCE.</p>
--

PRODUCT SPECIFICATIONS

HORSE POWER:	5 hp
DISPLACEMENT:	12.04 cu. in.
GASOLINE CAPACITY:	2 quarts Unleaded
OIL (21 oz. Capacity):	SAE 10W-30 (5W - 30)
SPARK PLUG : (GAP .030 In.)	Champion J8C
VALVE CLEARANCE:	Intake: .010 In. Exhaust: .010 In.

MAINTENANCE AGREEMENT

A Sears Maintenance Agreement is available on this product. Contact your nearest Sears Store for details.

CUSTOMER RESPONSIBILITIES

- Read and observe the safety rules.
- Follow a regular schedule in maintaining, caring for and using your snow thrower.
- Follow the instructions under "Maintenance" and "Storage" sections of this owner's manual.

TWO YEAR LIMITED WARRANTY ON CRAFTSMAN SNOW THROWER

For two years from the date of purchase, when this Craftsman Snow Thrower is maintained, lubricated and tuned-up according to the instructions in the owner's manual, Sears will repair, free of charge, any defect in material and workmanship.

If this Craftsman Snow Thrower is used for commercial or rental purposes, this warranty applies for only 90 days from the date of purchase.

This warranty does not cover the following:

- Expendable items which become worn during normal use, such as spark plugs, tire chains, drive belts and shear pins.
- Repairs necessary because of operator abuse or negligence, including bent crankshafts and the failure to maintain the equipment according to the instructions contained in the owner's manual.

WARRANTY SERVICE IS AVAILABLE BY RETURNING THE CRAFTSMAN SNOW THROWER TO THE NEAREST SEARS SERVICE CENTER/DEPARTMENT IN THE UNITED STATES. THIS WARRANTY APPLIES ONLY WHILE THIS PRODUCT IS IN USE IN THE UNITED STATES.

This warranty gives you specific legal rights, and you may also have other rights which may vary from state to state.

SEARS, ROEBUCK AND CO. Department 731CR-W Sears Tower, Chicago, IL. 60684

TABLE OF CONTENTS

SAFETY RULES	2,3	MAINTENANCE	15-16
PRODUCT SPECIFICATIONS.....	4	SERVICE AND ADJUSTMENTS	17-23
CUSTOMER RESPONSIBILITIES	4	STORAGE	24
WARRANTY	4	SERVICE RECOMMENDATIONS	25
TABLE OF CONTENTS	5	TROUBLE SHOOTING	26
INDEX	5	REPAIR PARTS (SNOW THROWER).....	28-36
ASSEMBLY	6-9	REPAIR PARTS (ENGINE).....	37-40
OPERATION	10-14	PARTS ORDERING/SERVICE	Back Cover

INDEX

<p style="text-align: center;">A</p> <p>Adjustment:</p> <ul style="list-style-type: none"> Auger Drive Belt 18, 19 Belts 18-20 Belt Guide 20 Cables 18 Carburetor 23 Friction Wheel 20 Scraper Bar 17 Spark Plug 23 Track 22 Track and Auger Drive Belts 18 <p>Assembly:</p> <ul style="list-style-type: none"> Crank Assembly 8 Shifter Lever 9 Skid Height Adjustment 7, 17 Unpacking 7 <p style="text-align: center;">B</p> <p>Belts:</p> <ul style="list-style-type: none"> Adjust Belts 18 Belt Guide Adjustment 20 Belt Maintenance 15 Replace Belts 19, 20 <p style="text-align: center;">C</p> <ul style="list-style-type: none"> Cables, Clutch 7, 9 Carburetor: 23, 24 Chain 15 Choke 10, 11, 13 Clutch, Levers 10, 11 <p>Controls:</p> <ul style="list-style-type: none"> Engine 10, 11, 13 Snow Thrower 10, 11, 12, 14 <p>Crank:</p> <ul style="list-style-type: none"> Adjusting Rod 8, 17 Assembly 8 Operation 11 <p>Customer Responsibilities 4</p> <p style="text-align: center;">D</p> <ul style="list-style-type: none"> Drive, Auger 11 Drive, Track 11 Deflector, Snow Chute 11 <p style="text-align: center;">E</p> <p>Engine:</p> <ul style="list-style-type: none"> Control 10, 11, 13 Oil Cap 12, 16 Oil Change 16 Oil Level 12, 16 Oil Type 4, 12, 16 Speed Governor 23 Starting the Engine 13 Storage 24 	<p style="text-align: center;">F</p> <ul style="list-style-type: none"> Fuel, Type 4, 12 Fuel, Storage 12, 24 <p>Friction Wheel:</p> <ul style="list-style-type: none"> Adjustment 20 Replacement 21 <p style="text-align: center;">G</p> <p>Gears:</p> <ul style="list-style-type: none"> Auger Gear Box 15, 16 Hex Shaft 15, 16 <p style="text-align: center;">H</p> <ul style="list-style-type: none"> Handle, Upper and Lower 7 Height Adjust Skids 7, 17 Hex Shaft 15, 16 <p style="text-align: center;">I</p> <ul style="list-style-type: none"> Ignition, Key 10, 11, 13 Index 5 <p style="text-align: center;">L</p> <p>Levers:</p> <ul style="list-style-type: none"> Auger Drive Clutch 10, 11 Choke 10, 11, 13 Shifter 9, 11 Throttle Control 10, 11, 13 Traction Drive Clutch 10, 11 <p>Lubrication:</p> <ul style="list-style-type: none"> Auger Gear Box 16 Auger Shaft 15 Chain and Sprockets 15 Chart 25 Engine 12, 16 Hex Shaft and Gears 15, 16 Weight Transfer System 15 <p style="text-align: center;">M</p> <p>Maintenance:</p> <ul style="list-style-type: none"> Agreement 4 Auger Gear Box 16 Auger Shaft 15 Chain and Sprockets 15 Engine 16 General Recommendations 15 Hex Shaft and Gears 15 Weight Transfer System 15 <p style="text-align: center;">O</p> <p>Oil:</p> <ul style="list-style-type: none"> Engine 4, 12, 16 Extreme Cold Weather 12, 16 Storage 24 Type 4, 12, 16 	<p>Operation:</p> <ul style="list-style-type: none"> Engine Controls 10, 11, 13 Operating Snow Thrower 11, 12, 14 Operating Tips 14 Starting the Engine 13 Snow Thrower Controls 10-12, 14 Weight Transfer System 12 <p style="text-align: center;">P</p> <ul style="list-style-type: none"> Parts 28-40 Primer Button 10, 11, 13 <p style="text-align: center;">R</p> <ul style="list-style-type: none"> Repair/Replacement Parts 28-40 <p>Replacements:</p> <ul style="list-style-type: none"> Auger Shear Bolt 22 Belts 19, 20 Friction Wheel 21 <p style="text-align: center;">S</p> <ul style="list-style-type: none"> Safety Rules 2-3 <p>Service and Adjustments:</p> <ul style="list-style-type: none"> Auger Housing Height 17 Auger Shear Bolt 22 Belts 18-20 Belt Guide 20 Belt Replacements 19, 20 Cable 18 Crank 17 Carburetor 23 Friction Wheel 20, 21 Scraper Bar 17 Shear Bolt 22 Spark Plug 23 Track 22 Service Recommendations 25 Spark Plug 16, 23 Specifications 4 Speed Governor 23 Starting the Engine 13 Stopping the Engine 11, 13 Stopping the Snow Thrower 11 Shipping Carton 6, 7 Skid Height 7, 17 Shifter Lever 9-11 Shear Bolts 22 Storage 24 <p style="text-align: center;">T</p> <ul style="list-style-type: none"> Table of Contents 5 Trouble Shooting Chart 26 Tools for Assembly 6 Track Drive Belt 18, 20 Track Adjustment 22 <p style="text-align: center;">W</p> <ul style="list-style-type: none"> Warranty 4 Weight Transfer System 12, 15
--	--	---



ASSEMBLY

THIS SNOW THROWER IS EQUIPPED WITH "TRAC-PLUS" AND ONLY MOVES EFFECTIVELY WHEN ENGINE IS RUNNING

If your snow thrower must be moved without the aid of the engine, it will be easier to pull the snow thrower backward by the handles, rather than pushing.

On start up, the track drive system may be tight and will loosen up as the snow thrower is used. After first use, check the track for tension and adjust if necessary. See the Track Adjustment paragraph in the Service and Adjustments section of this manual. Check track adjustment and fasteners regularly.

CONTENTS OF SHIPPING CARTON

1 - Snow thrower completely assembled except for the crank assembly, shifter lever assembly and knob, and the upper handle, which is in the folded down position.

1 - Parts Bag Containing:

1 - Owner's Manual (Not Shown)

Parts Shown Below:

TOOLS REQUIRED FOR ASSEMBLY

1 - Knife (to cut carton and plastic ties)

2 - 1/2 inch Wrenches (or adjustable wrenches)

2 - 9/16 inch Wrenches (or adjustable wrenches)

2 - 3/4 inch Wrenches (or adjustable wrenches)

1 - Pair Pliers (to spread cotter pin)

1 - Screwdriver

PARTS BAG CONTENTS

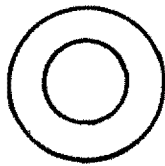

2 - 3/8 In. Flat Washers



2 - Spare Spacers

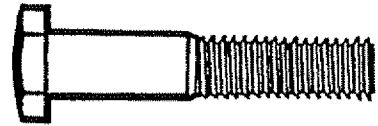

1 - 3/8 - 16 x 2 inch Hex Head Bolt



2 - 1/4 - 20 x 1 - 3/4 In.
Hex Head Bolts



1 - 3/8 In. Hex Nut



1 - 3/8 In. Split Lockwasher

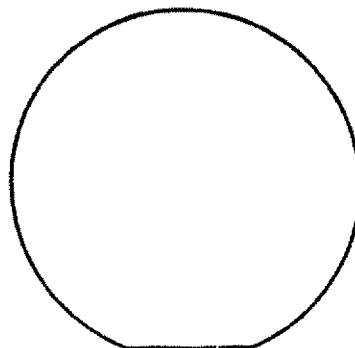

1 - Knob With Threads



2 - Spare 1/4 - 20 Locknuts

ASSEMBLY

Figure 1 shows the snow thrower in the shipping position. Figure 2 shows the snow thrower completely assembled. Reference to the right and left hand side of the snow thrower is from the operator's position at the handle.

TO REMOVE SNOW THROWER FROM CARTON (See Fig 1)

- Cut all four corners of the carton from top to bottom and lay the panels flat.
- Cut the cable ties attached to the auger.
- Cut and discard the plastic ties that secure the crank assembly and place the assembly aside.
- Remove the packing material from the control panel.
- Cut and discard the packing securing the clutch cables to the handles.
- Loosen (do not remove) both bolts securing the upper and lower handles. Swing the upper handle into the operating position.

NOTE: If the cables have become disconnected from the clutch levers, reinstall the cables as shown in Figure 3.

- Tighten both bolts securely.
- Roll the snow thrower off the skid by pulling on the handle.

NOTE: This snow thrower is equipped with a track drive and can be hard to push when the engine is not running. It is easier to pull the snow thrower backward if it must be moved without the engine running.

The drive system may be tight when you first use your snow thrower. It loosens up as you use it.

HOW TO SET UP YOUR SNOW THROWER

TO SET THE SKID HEIGHT

- To adjust the skids height for different conditions, see To Adjust Skids Height paragraph on page 17.



CAUTION: IF YOU ARE REMOVING SNOW FROM ANY ROCKY OR UNEVEN SURFACES, RAISE THE FRONT OF THE SNOW THROWER BY MOVING THE SKIDS DOWN. THIS WILL HELP TO PREVENT ROCKS AND OTHER DEBRIS FROM BEING PICKED UP AND THROWN BY THE AUGER.

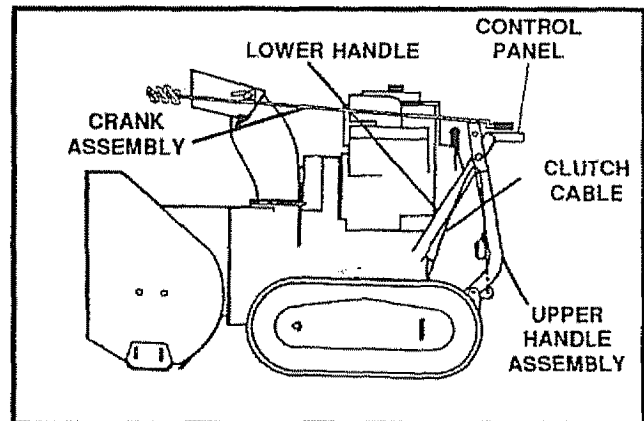

FIG. 1

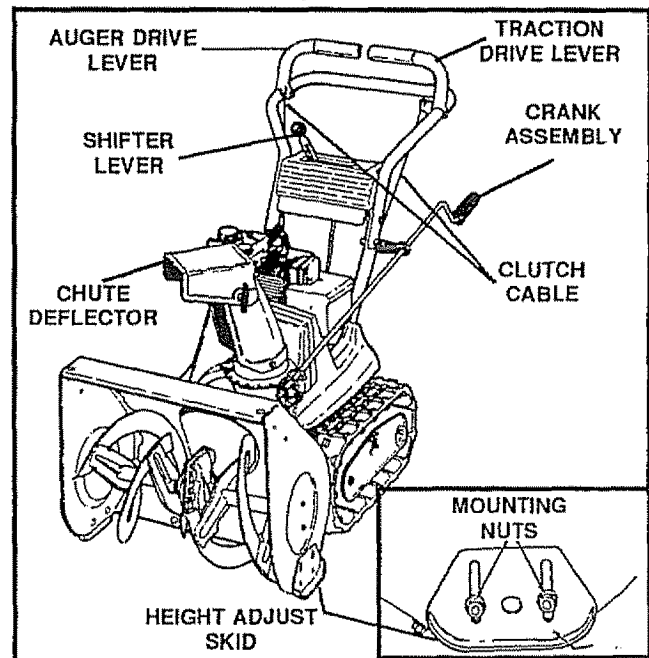

FIG. 2

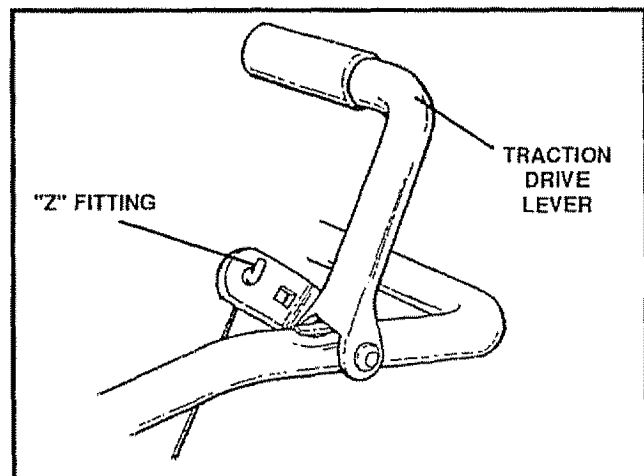

FIG. 3

ASSEMBLY

TO INSTALL THE UPPER HANDLE AND CRANK ASSEMBLY

- On the right side of the handle, install and secure the following parts (found in parts bag) in the lower handle hole as shown in figure 4A:
 - 1 - 3/8" x 2" bolt
 - 2 - 3/8" flat washers & 1 - 3/8" split lockwasher
 - 1 - 3/8" nut
- Remove the 3/8" nylon locknut and flatwasher from the "eye" bolt assembly (on the chute crank assembly) and adjust the remaining 3/8" nut and flatwasher on the "eye" bolt about half way up the thread.
- Install "eye" bolt through lower hole on the left hand side of the handle.
- Install the 3/8" flatwasher and the 3/8" nylon locknut loosely on the "eye" bolt, as shown.
- Remove the plastic cap, the cotter pin and the washer from the wormed end of the crank assembly and set aside (See Fig. 5).
- Rotate the notched section of the discharge chute toward the crank-adjusting rod.
- Install the wormed end of the crank through the hole in the adjusting rod and secure the end with the flat washer and cotter pin, as shown in Fig. 5.
- Bend the ends of the cotter pin around the rod and re-install the plastic cap.
- Tighten the eye bolt installed earlier, keep eye in line with the rod while tightening the inside nut securely.
- Tighten the outside 3/8" jam nut up against the other 3/8" jam nut (See Fig. 4B).
- Rotate the chute crank fully clockwise and fully counter-clockwise. The discharge chute should rotate fully to the outer diameter of the worm and should clear approximately 1/8" (see Fig. 5). If the chute crank needs to be adjusted, go to the Service and Adjustments section on page 17.

NOTE: Be sure the crank does not touch the side of the engine or the cover will be scratched.

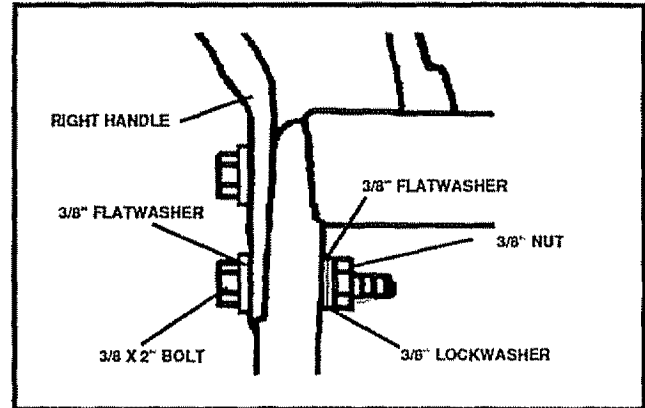

FIG. 4A

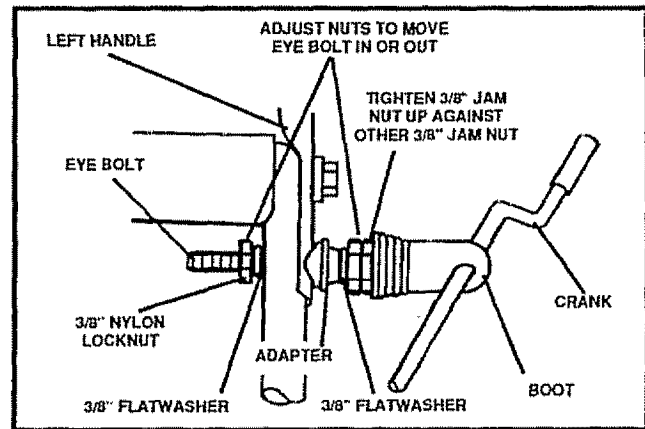

FIG. 4B

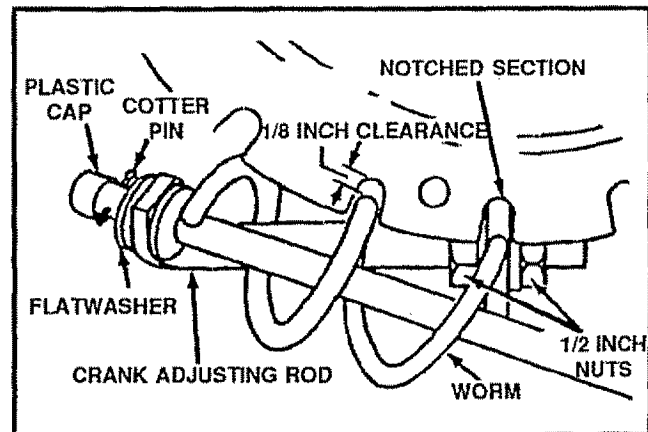

FIG. 5

ASSEMBLY

TO INSTALL THE SHIFTER LEVER

- Stand the snow thrower up on the front of the auger housing, as shown in Figure 6.
- Cut the plastic tie which holds the shifter lever assembly to the shift bracket.
- Remove the locknut, washer, spring and the bolt. Reposition the shifter lever into the slot in the control panel, as shown in Figure 6 and reinstall the bolt, spring washer and the locknut.
- Tighten the locknut until 1/8" to 3/16" (2 or 3 threads) of the bolt protrude past the locknut.
- Thread the shifter lever knob onto the threaded end of the shifter lever until it is tight.
- Move the shifter lever through all the speeds to ensure proper tension of the spring. If the shifter lever sticks in any of the notches, loosen the locknut 1/4 turn at a time until the shifter lever moves freely.

TO CHECK/ADJUST CLUTCH CONTROL CABLES

The control cables attached to the auger clutch lever and traction clutch lever may need to be adjusted before you use your snow thrower.

For instructions on checking or adjusting the clutch control cables, see To Adjust The Clutch Control Cables paragraph on page 18.

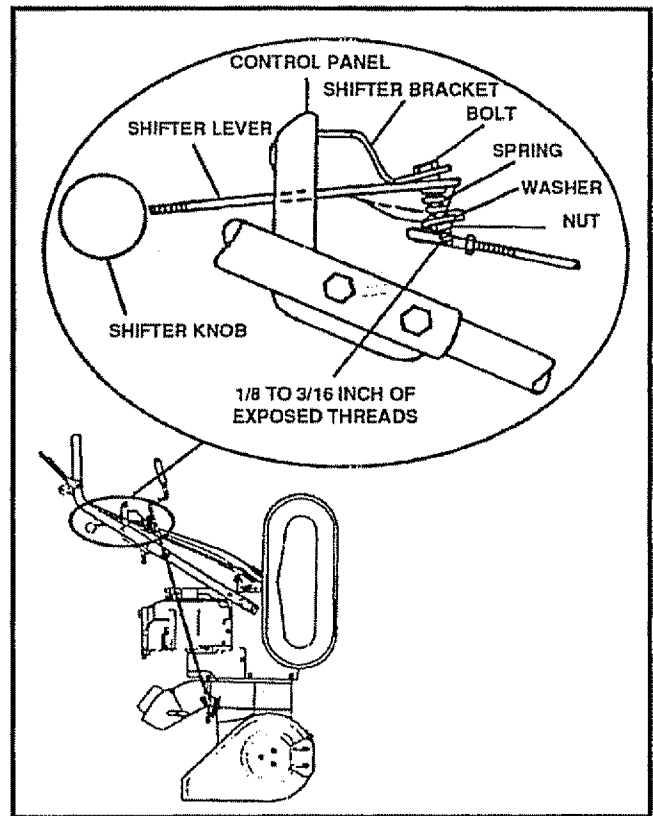

FIG. 6

OPERATION

KNOW YOUR SNOW THROWER

READ THIS OWNER'S MANUAL AND SAFETY RULES BEFORE OPERATING YOUR SNOW THROWER. Compare the illustrations with your snow thrower to familiarize yourself with the location of various controls and adjustments. Save this manual for future reference.

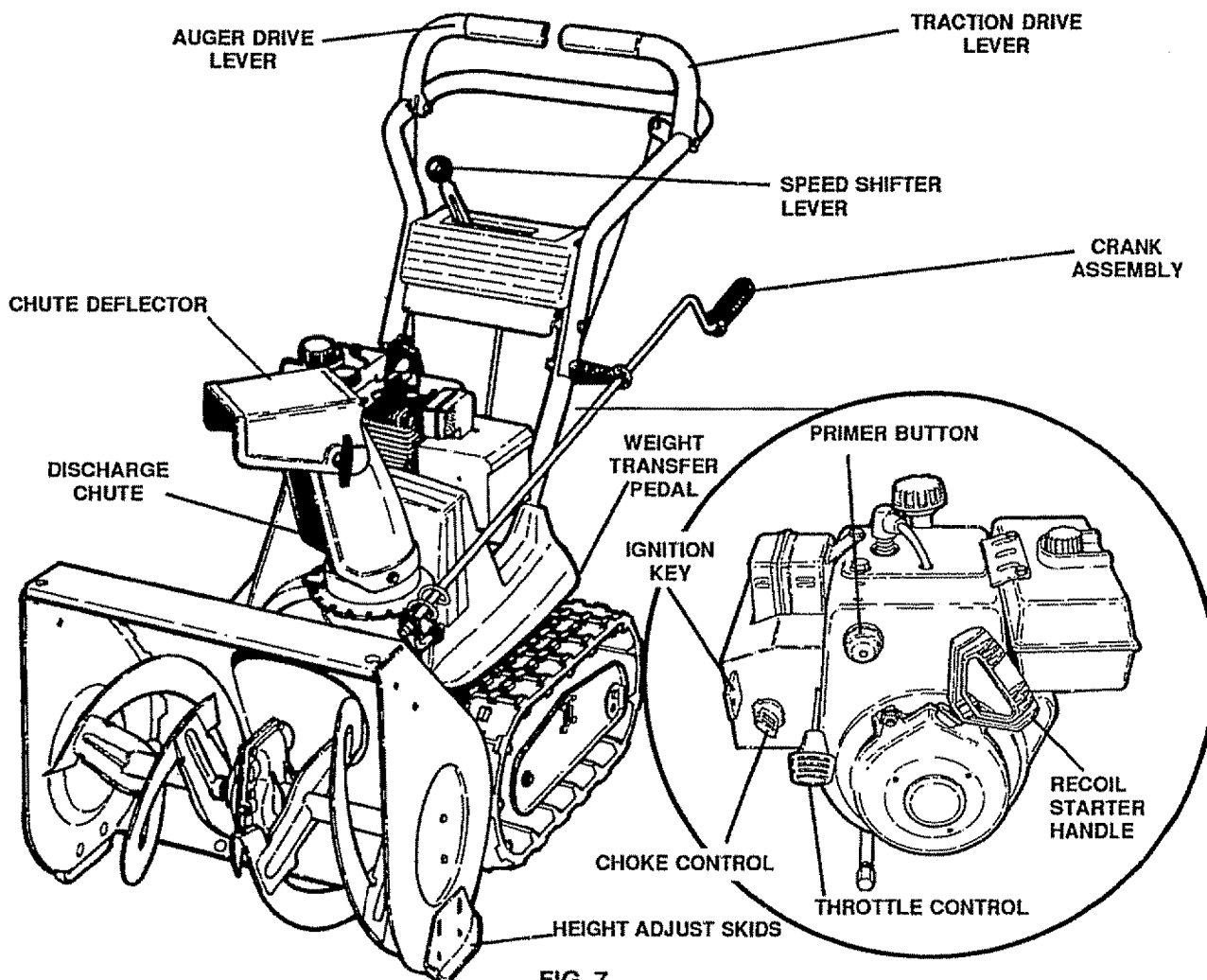

FIG. 7

SEARS TRAC-PLUS SNOW THROWERS conform to the safety standards of the American National Standards Institute.

AUGER DRIVE LEVER - Starts and stops the auger and impeller (snow gathering and throwing).

TRACTION DRIVE LEVER - Propels the snow thrower forward and in reverse.

SPEED SHIFTER LEVER - Selects the speed of the snow thrower (6 speeds forward and 2 speeds reverse).

CRANK ASSEMBLY - Changes the direction of snow throwing through the discharge chute.

CHUTE DEFLECTOR - Changes the distance the snow is thrown.

DISCHARGE CHUTE - Changes the direction the snow is thrown.

WEIGHT TRANSFER PEDAL - Engage for heavy snow conditions, to keep the snow thrower from climbing drifts and hard-packed snow. When released, it eases transport of the snow thrower.

HEIGHT ADJUST SKIDS - Adjusts the ground clearance of the auger housing.

IGNITION KEY - Must be inserted to start the engine.

RECOIL STARTER HANDLE - Starts the engine manually.

CHOKE CONTROL - Used to start a cold engine.

PRIMER BUTTON - Injects fuel directly into the carburetor manifold for fast starts in cold weather.

THROTTLE CONTROL - Controls the engine speed.

OPERATION



The operation of any snow thrower can result in foreign objects being thrown into the eyes, which can result in severe eye damage. Always wear safety glasses or eye shields while operating the snow thrower.

We recommend standard safety glasses or Wide Vision Safety Mask for over your glasses available at SEARS Retail or Catalog Stores.

HOW TO USE YOUR SNOW THROWER

TO CONTROL SNOW DISCHARGE

- Turn the crank assembly to set the **direction** of the snow throwing.
- Loosen the wing knob on the chute deflector and move the deflector to set the **distance**. Move the deflector **UP** for more distance, **DOWN** for less distance. Then tighten the wing knob (See Fig. 8).

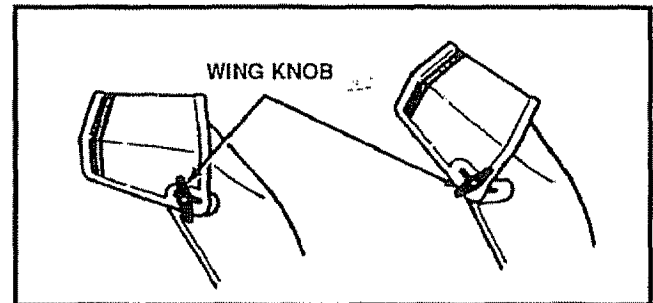

FIG. 8

TO STOP YOUR SNOW THROWER

- To stop throwing snow, release the auger drive lever (See Fig. 10).
- To stop the track, release the traction drive lever.
- To stop the engine, push the throttle control lever to "STOP" and pull out the ignition key (See Fig. 9).

TO MOVE FORWARD AND BACKWARD

- To shift, release the traction drive lever and move the speed shifter lever to the speed you desire. Ground speed is determined by snow conditions. Select the speed you desire by moving the speed shifter lever into the appropriate colored area on the control panel.

Red - Wet, Heavy, Slushy, Extra Deep

Amber - Moderate

White - Very Light

Green - Transport only

- Engage the traction drive lever (See Fig 10, left hand). As the snow thrower starts to move, maintain a firm hold on the handles, and guide the snow thrower along the clearing path. Do not attempt to push the snow thrower.
- To move the snow thrower backward, move the speed shifter lever into first or second reverse and engage the traction drive lever (left hand).

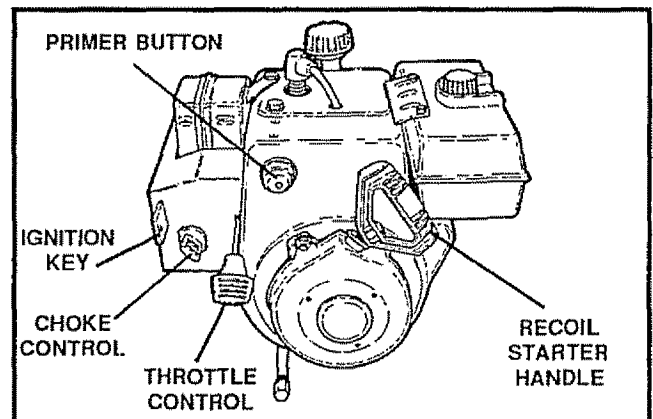

FIG. 9

IMPORTANT: DO NOT MOVE THE SPEED SHIFTER LEVER WHILE THE TRACTION LEVER IS DOWN.

TO THROW SNOW

- Push down the auger drive lever (See Fig. 10, right hand).
- Release to stop throwing snow.

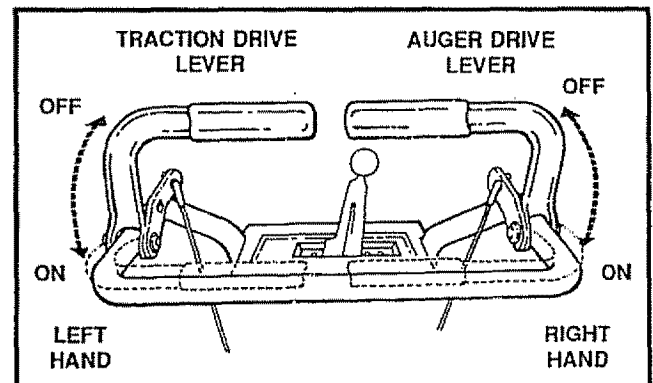

FIG. 10



CAUTION: READ OWNER'S MANUAL BEFORE OPERATING MACHINE. NEVER DIRECT DISCHARGE TOWARD BYSTANDERS. STOP THE ENGINE BEFORE UNCLOGGING DISCHARGE CHUTE OR AUGER HOUSING AND BEFORE LEAVING THE MACHINE.

OPERATION

TO USE WEIGHT TRANSFER SYSTEM

In hard packed or heavy snow conditions, conventional snow throwers tend to ride up and leave uneven mounds of snow behind. For these conditions, your new tracked snow thrower has a unique weight transfer system (See Fig. 11) designed to minimize ride-up.

Stepping on the weight transfer pedal shifts more weight to the auger housing. This weight transfer keeps the snow thrower in contact with the ground and reduces ride-up.

In lighter snow conditions or when transporting, you should release the weight transfer system for easier steering.

- To use the weight transfer, hold the upper handle firmly and push down on the weight transfer pedal (See Fig. 11) with the ball of your foot.
- To release, pull up on the weight transfer pedal with the top of your foot.

NOTE: The weight transfer system will not work if the auger housing height adjust skids are adjusted to the highest position.

BEFORE STARTING THE ENGINE

FILL/ ADD OIL:

The engine on this snow thrower was shipped **without oil**. Add oil before you start the engine. Remove the oil fill cap/dipstick and fill the crank case to FULL line on dipstick (about 21 ounces) (See Fig. 12) with S.A.E. 10 W-30 motor oil (or equivalent). Do not overfill. Tighten the fill cap/dipstick securely each time you check the oil level.

NOTE: S.A.E. 5W-30 motor oil may be used to make starting easier in areas where temperature is consistently 20° F. or lower.

FILL GAS:

WARNING: Experience indicates that alcohol blended fuels (called gasohol or using ethanol or methanol) can attract moisture which leads to separation and formation of acids during storage. Acidic gas can damage the fuel system of an engine while in storage.

To avoid engine problems, the fuel system should be emptied before storage for 30 days or longer. Drain the gas tank, start the engine and let it run until the fuel lines and carburetor are empty. Use the carburetor bowl drain to empty residual gasoline from the float chamber (Figure 39). Use fresh fuel next season. (See Storage instructions on page 24 for additional information.)

Fill the fuel tank with clean, fresh, unleaded grade automotive gasoline. Be sure that the container you pour the gasoline from is clean and free from rust or other foreign particles. Never use gasoline that may be stale from long periods of storage in the container.

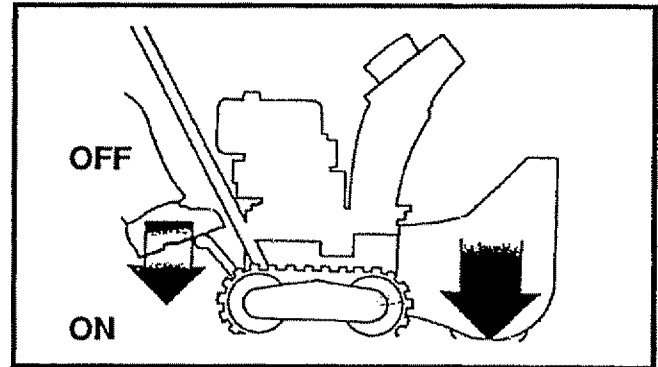

FIG.11

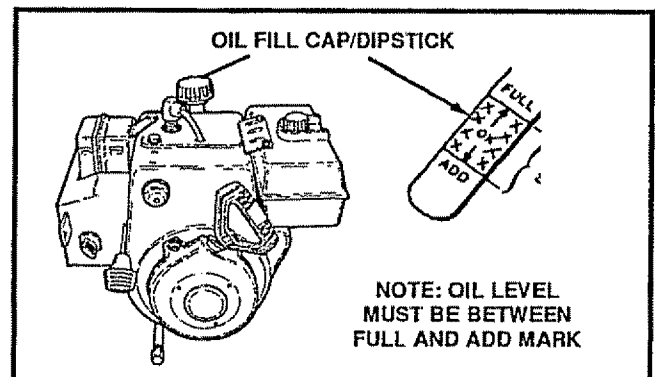

FIG.12

Never use engine or carburetor cleaner products in the fuel tank or permanent damage may occur.



CAUTION: GASOLINE IS FLAMMABLE AND CAUTION MUST BE USED WHEN HANDLING OR STORING IT.

DO NOT FILL FUEL TANK WHILE SNOW THROWER IS RUNNING, WHEN IT IS HOT, OR WHEN SNOW THROWER IS IN AN ENCLOSED AREA.

KEEP AWAY FROM OPEN FLAME OR AN ELECTRICAL SPARK AND DO NOT SMOKE WHILE FILLING THE FUEL TANK.

NEVER FILL THE TANK COMPLETELY. FILL THE TANK TO WITHIN 1/4" - 1/2" FROM THE TOP TO PROVIDE SPACE FOR EXPANSION OF FUEL. ALWAYS FILL FUEL TANK OUTDOORS AND USE A FUNNEL OR SPOUT TO PREVENT SPILLING.

MAKE SURE TO WIPE UP ANY SPILLED FUEL BEFORE STARTING THE ENGINE.

STORE GASOLINE IN A CLEAN, APPROVED CONTAINER AND KEEP THE CAP IN PLACE ON THE CONTAINER.

OPERATION



CAUTION: NEVER RUN ENGINE IN-DOORS OR IN ENCLOSED, POORLY VENTILATED AREAS. ENGINE EXHAUST CONTAINS CARBON MON-OXIDE, AN ODORLESS AND DEADLY GAS. KEEP HANDS, FEET, HAIR AND LOOSE CLOTHING AWAY FROM ANY MOVING PARTS ON ENGINE AND SNOW THROWER.

WARNING: TEMPERATURE OF MUFFLER AND NEARBY AREAS MAY EXCEED 150° F. AVOID THESE AREAS.

DO NOT ALLOW CHILDREN OR YOUNG TEEN-AGERS TO OPERATE OR BE NEAR SNOW THROWER WHILE IT IS OPERATING.

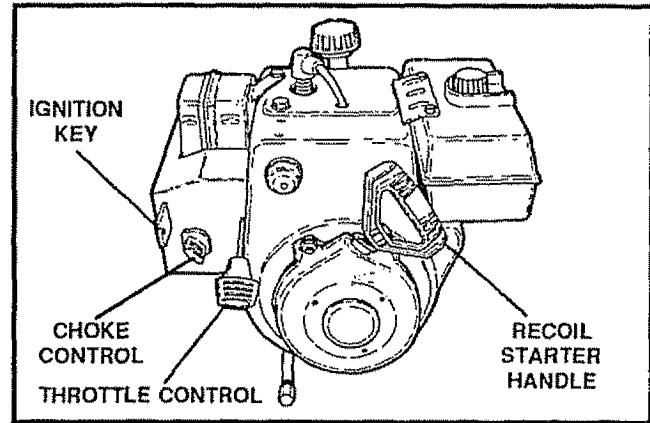

FIG.13

TO STOP ENGINE

- To stop engine, move the throttle control lever to "STOP" position and remove key. Keep the key in a safe place. The engine will not start without the key.

TO START ENGINE

Be sure that the engine has sufficient oil. Before starting the engine, be certain that you have read the following information:

COLD START (See Fig. 13)

- Be sure the auger and the traction drive levers are in the disengaged "RELEASED" position.
- Move the throttle control up to "FAST" position.
- Remove the keys from the plastic bag. Insert one key into the ignition slot. Be sure it snaps into place. DO NOT TURN KEY. Keep the second key in a safe place.
- Rotate choke control to "FULL" choke position.
- Press the primer button two or three times, while keeping your finger over the vent hole on the primer button. Additional priming may be necessary for the first start if the temperature is below 15° F.
- Pull the starter handle rapidly. Do not allow the handle to snap back, but allow it to rewind slowly while keeping a firm hold on the starter handle.
- As the engine warms up and begins to operate evenly, rotate the choke knob slowly to "OFF" position. If the engine falters, return to "FULL" choke, then slowly move to "OFF" choke position.

NOTE: Allow the engine to warm up for a few minutes because the engine will not develop full power until it reaches operating temperature.

- Run the engine at or near the top speed when throwing snow.

WARM START

If restarting a warm engine after a short shutdown, rotate choke to "OFF" instead of "FULL" and do not push the primer button.

FROZEN STARTER

If the starter is frozen and will not turn engine:

- Pull as much rope out of the starter as possible.
- Release the starter handle and let it snap back against the starter

If the engine still fails to start, repeat. If continued attempts do not free starter, follow the electric starter procedures to start.

To help prevent possible freeze-up of recoil starter and engine controls, proceed as follows after each snow removal job.

- **With the engine running**, pull the starter rope hard with a continuous full arm stroke three or four times. Pulling of starter rope will produce a loud clattering sound. This is not harmful to the engine or starter.
- **With the engine not running**, wipe all snow and moisture from the carburetor cover in area of control levers. Also move throttle control, choke control, and starter handle several times.

OPERATION

SNOW THROWING TIPS

- For maximum snow thrower efficiency, adjust ground speed, not throttle. If the track slips, reduce forward speed. The engine is designed to deliver maximum performance at full throttle and should be run at this power setting at all times.
- Most efficient snow blowing is accomplished when the snow is removed immediately after it falls.
- For complete snow removal, slightly overlap each path previously taken.
- The snow should be discharged down wind whenever possible.
- For normal usage, set the skids so that the scraper bar is 1/8" above the skids. For extremely hard-packed snow surfaces, adjust the skids upward so that the scraper bar touches the ground.
- On gravel or crushed rock surfaces, set the skids at 1-1/4" below the scraper bar (see To Adjust Skids Height paragraph on page 17). Rocks and gravel must not be picked up and thrown by the machine.
- If the front of the snow thrower has a tendency to raise, reduce the ground speed and engage the weight transfer system.
- After the snow blowing job has been completed, allow the engine to idle for a few minutes, which will melt snow and accumulated ice off the engine.
- Clean the snow thrower thoroughly after each use.
- Remove ice and snow accumulation and all debris from the entire snow thrower, and flush with water (if possible) to remove all salt or other chemicals. Wipe snow thrower dry.



CAUTION: DO NOT ATTEMPT TO REMOVE ANY ITEM THAT MAY BECOME LODGED IN AUGER WITHOUT TAKING THE FOLLOWING PRECAUTIONS:

- **RELEASE AUGER DRIVE AND TRACTION DRIVE LEVERS.**
- **MOVE THROTTLE LEVER TO STOP POSITION.**
- **REMOVE (DO NOT TURN) IGNITION KEY.**
- **DISCONNECT SPARK PLUG WIRE.**
- **DO NOT PLACE YOUR HANDS IN THE AUGER OR DISCHARGE CHUTE. USE A PRY BAR.**

MAINTENANCE

GENERAL RECOMMENDATIONS

The warranty on this snow thrower does not cover items that have been subjected to operator abuse or negligence. To receive full value from the warranty, operator must maintain snow thrower as instructed in this manual.

Some adjustments will need to be made periodically to properly maintain your snow thrower.

All adjustments in the Service and Adjustments section of this manual should be checked at least once each season.

AFTER FIRST USE

- Check the tracks for tension and adjust if necessary (See To Adjust Track paragraph on page 22). Check the track adjustment and fasteners regularly.
- Be sure that all fasteners are tight.

AS REQUIRED

The following adjustments should be performed more than once each season.

- Auger and Track Drive Belts should be adjusted after the first 2 to 4 hours of use and again about mid-season and twice each season thereafter. See To Adjust Belts paragraph on page 18.
- All screws and nuts should be checked often to make sure they are tight, preferably after each use.

SNOW THROWER

LUBRICATION - EVERY TEN HOURS

- Chains and Sprockets - Oil chains and sprockets (See Fig. 14) with 10W-30 oil (or equivalent) after 10 hours use and at the end of each season.
- Weight Transfer System - Coat weight transfer plate (See Fig. 15) with clinging type grease, such as lubriplate, every ten (10) hours and before storage.
- Auger Shaft - Using a hand grease gun, lubricate the auger shaft zerk fittings (See A, Fig. 16) every ten (10) operating hours. Each time a shear bolt is replaced (see To Replace Auger Shear Bolt paragraph on page 22), the auger shaft MUST be greased.
- For storage or when replacing shear bolts, remove shear bolts and lubricate auger shaft zerk. Rotate augers several times on the shaft and reinstall the shear bolts.

LUBRICATION - NOT REQUIRED

- Hex Shaft and Gears - Hex shaft and gears require no lubrication. All bearings and bushings are lifetime lubricated and require no maintenance (See Fig. 17).

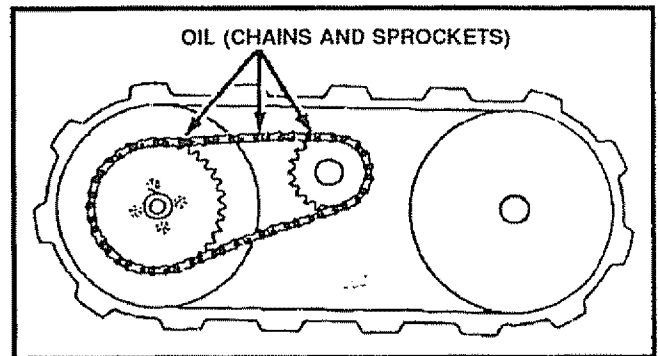

FIG. 14

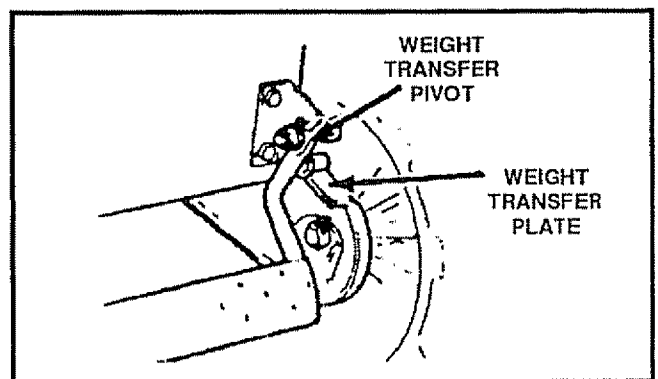

FIG. 15

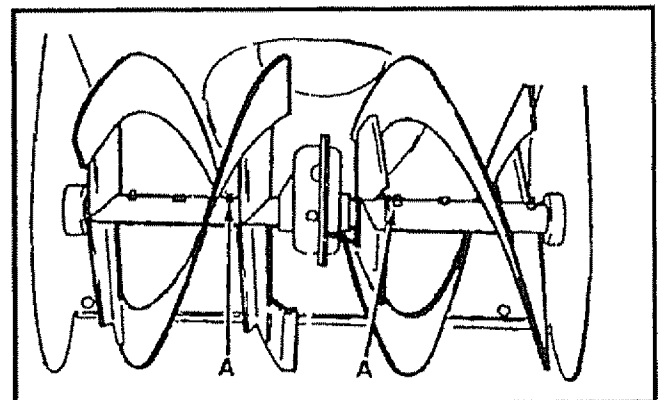

FIG.16

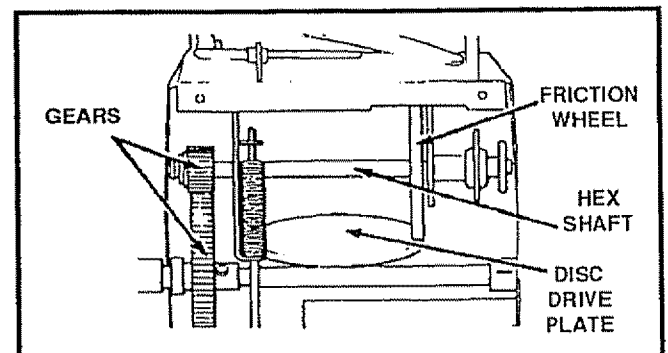

FIG.17

MAINTENANCE

NOTE: Any greasing or oiling of the above components can cause contamination of the friction wheel. If the disc drive plate or friction wheel come in contact with grease or oil, damage to the friction wheel will result.

Should grease or oil come in contact with the disc drive plate or friction wheel, be sure to clean the plate and wheel thoroughly.

NOTE: For storage, the hex shaft and gears should be wiped with 10W-30 motor oil to prevent rusting (See Fig. 17).

- Auger Gear Box - The auger gear box has been factory lubricated for life. If for some reason lubricant should leak out, have auger gear case checked by a competent repairman.

ENGINE

LUBRICATION

Check the crankcase oil level (See Fig. 18) before starting the engine and after each five (5) hours of continuous use. Add S.A.E. 10W-30 motor oil or equivalent. Tighten fill cap/dipstick securely each time you check the oil level. S.A.E. 5W-30 motor oil may be used to make starting easier in areas where temperature is consistently 20° F. or lower.

Change the oil after first two hours of operation and every 25 hours thereafter or at least once a year if the snow thrower is not used for 25 hours. (See Fig. 19).

- Position snow thrower so that the oil drain plug is lowest point on the engine. Remove oil drain plug and oil fill cap/dipstick. Drain oil into a suitable container. Oil will drain more freely when warm.
- Replace oil drain plug and tighten securely. Refill crankcase with S.A.E. 10W-30 motor oil (or equivalent). S.A.E. 5W-30 motor oil may be used to make starting easier in areas where temperature is consistently 20° F. or lower.

SPARK PLUG

- Make sure that the spark plug is tightened securely into the engine and the spark plug wire is attached to the spark plug.
- If a torque wrench is available, torque plug to 18 to 23 foot pounds.
- Clean the area around the spark plug base before removal to prevent dirt from entering the engine.
- Clean the spark plug and reset the gap periodically.

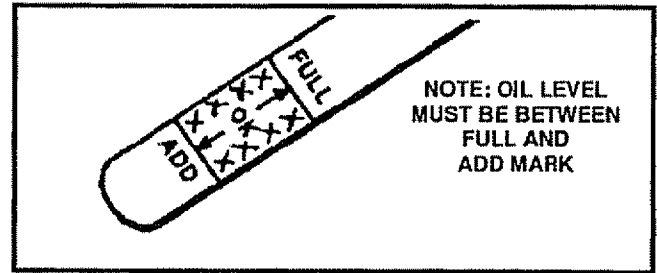

FIG. 18

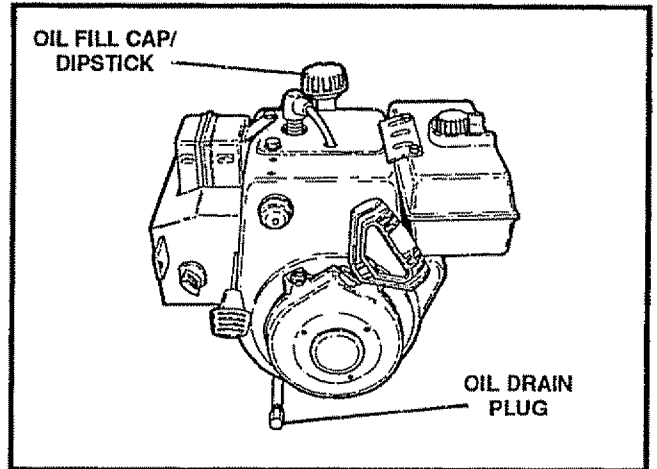

FIG. 19

SERVICE AND ADJUSTMENTS



CAUTION: ALWAYS DISCONNECT THE SPARK PLUG WIRE AND TIE BACK AWAY FROM THE PLUG BEFORE MAKING ANY ADJUSTMENTS OR REPAIRS.

TO ADJUST SKIDS HEIGHT

This snow thrower is equipped with two height adjustment skids, located on the outside of the auger housing. These skids elevate the front of the snow thrower.

For normal hard surfaces, adjust the skids as follows:

- Make sure the snow thrower is on a hard, level surface and the weight transfer system lever is released. See page 12.
- Place extra shear bolts supplied (found in parts bag) under each end of the scraper bar near but not under the skids.
- Loosen the skid mounting nuts (See Fig. 20) and push the skids down until they touch the ground. Retighten the mounting nuts.

For rocky or uneven surfaces, raise the front of the snow thrower by moving the skids down. This will help prevent rocks and other debris from being picked up and thrown by the auger.

NOTE: If the skids are at the maximum height, the weight transfer system will not work.

TO ADJUST SCRAPER BAR

After considerable use, the metal scraper bar will have a definite wear pattern. The scraper bar in conjunction with the skids should always be adjusted to allow 1/8" between the scraper bar and the sidewalk or area to be cleaned.

- Position the snow thrower on a level surface.
- Loosen the carriage bolts and nuts securing the scraper bar to the auger housing.
- Adjust the scraper bar to the proper position.
- Tighten the carriage bolts and nuts, making sure that the scraper bar is parallel with the working surface.
- After extended operation, the scraper bar may be reversed. If the scraper bar must be replaced due to wear, remove the carriage bolts and nuts and install a new scraper bar.

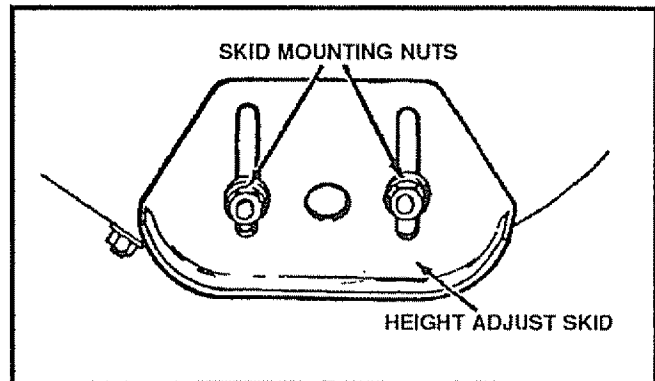

FIG. 20



CAUTION: BE CERTAIN TO MAINTAIN PROPER GROUND CLEARANCE FOR YOUR PARTICULAR AREA TO BE CLEARED. OBJECTS SUCH AS GRAVEL, ROCKS OR OTHER DEBRIS, IF STRUCK BY THE IMPELLER, MAY BE THROWN WITH SUFFICIENT FORCE TO CAUSE PERSONAL INJURY, PROPERTY DAMAGE OR DAMAGE TO THE SNOW THROWER.

TO ADJUST CHUTE CRANK ASSEMBLY

If you cannot rotate the chute crank fully to the left and to the right, you need to adjust the chute crank (See Fig. 21).

- Loosen both 1/2" nuts on the crank adjusting rod (using 3/4" wrenches).
- Rotate the adjusting rod in or out to allow about 1/8" clearance between the notch in the flange and the outer diameter of the worm.
- Once this clearance is set, tighten the nuts.

NOTE: Be sure the crank does not touch the side of the engine or the cover will be scratched.

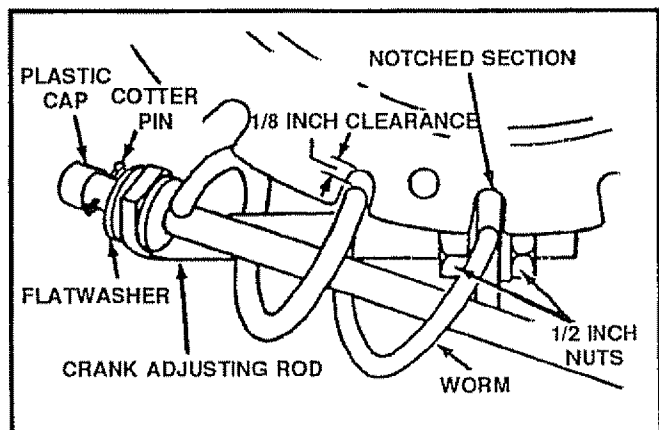

FIG. 21

SERVICE AND ADJUSTMENTS

TO ADJUST THE CLUTCH CONTROL CABLES

Periodic adjustment of the cables may be required due to normal stretch and wear on the belts. To check for correct adjustment, the control lever must be in the full forward position, resting on the plastic bumper. The control cables are correctly adjusted when the center of the "Z" Fitting is in the center of the hole and there is no droop in the cable (See Fig. 22).

If adjustment is necessary:

- Push the cable through the spring (See Fig. 23) to expose the threaded portion of the cable.
- Hold the square end of the threaded portion with pliers and adjust the locknut in or out until the excess slack is removed.
- Pull the cable back through the spring and connect the cable.
- Do the same for the other lever cable.

NOTE: Whenever the track drive or auger belts are adjusted or replaced, the cables will need to be adjusted.

TO ADJUST BELTS

Belts stretch during normal use. If you need to adjust the belts due to wear or stretch, proceed as follows:

TRACK DRIVE BELT (See Fig. 25)

The track drive belt has constant spring pressure and does not require adjustment. Check the clutch control cable adjustment before replacing the belt.

Replace the track drive belt if it is still slipping (see To Replace Belts paragraph on page 19).

AUGER DRIVE BELT (See Fig. 25)

If your snow thrower will not discharge snow, check the control cable adjustment. If it is correct, then check the condition of the auger drive belt. It may be loose or damaged. If it is damaged, replace it. See To Replace Belts paragraph on page 19. If the auger drive belt is loose, adjust as follows:

- Disconnect the spark plug wire.
- Remove the belt cover.
- Loosen the nut on the idler pulley (See Fig. 24) and move the pulley toward the belt about 1/8".
- Tighten the nut.
- Press the auger drive lever. Check the tension on the belt (opposite idler pulley). The belt should deflect about 1/2" with moderate pressure (See Fig. 24).

NOTE: You may have to move the idler pulley more than once to obtain the correct tension.

- Replace the belt cover.
- Check the clutch control cable adjustment.
- Reconnect the spark plug wire.

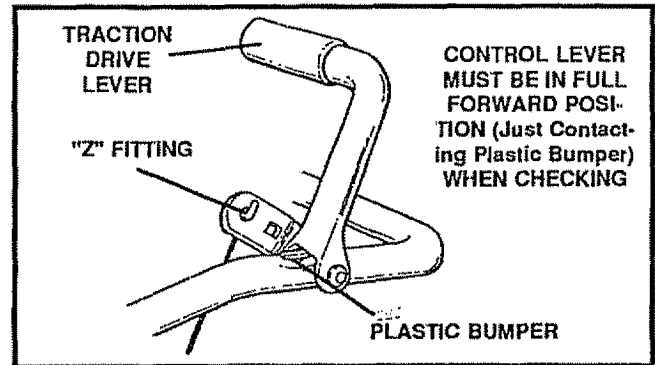

FIG. 22

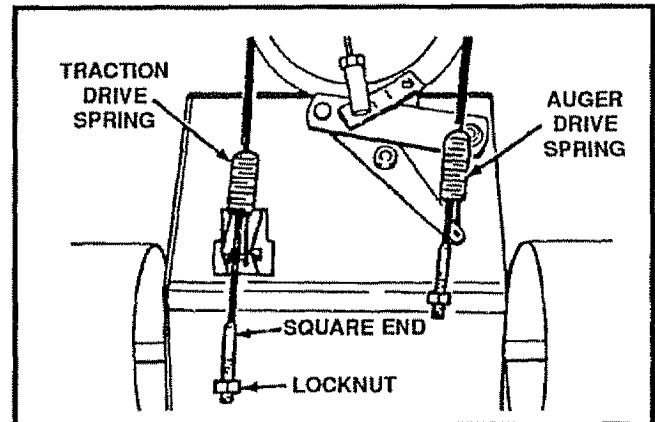

FIG. 23

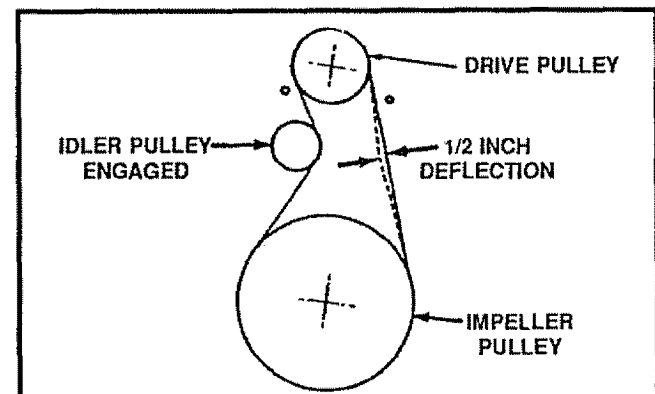

FIG. 24

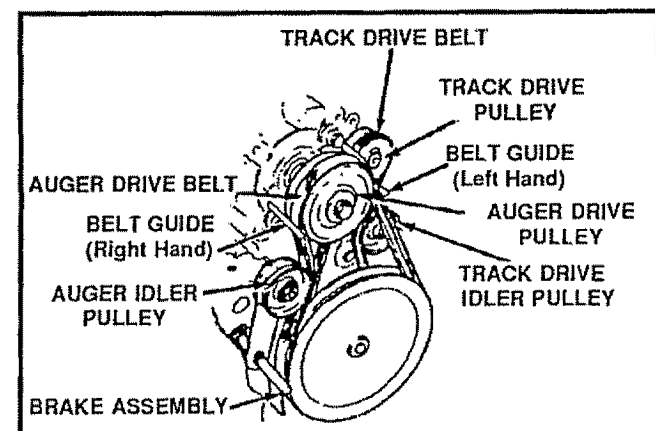

FIG. 25

SERVICE AND ADJUSTMENTS

TO REPLACE BELTS

The drive belts on this snow thrower are of special construction and should be replaced with original equipment belts available from your nearest SEARS Store or Service Center.

You will need the assistance of a second person while replacing the belts.

Drain the gasoline from the fuel tank by removing the fuel line. Drain the gas and reinstall fuel line.



CAUTION: DRAIN THE GASOLINE OUT DOORS, AWAY FROM FIRE OR FLAME.

AUGER DRIVE BELT

If your snow thrower will not discharge snow, and the auger drive belt is damaged, replace it as follows:

- Disconnect the spark plug wire.
- Remove the belt cover (See Fig. 26)
- Loosen the belt guides (See Fig. 28) and pull away from the drive pulley.
- Loosen the auger idler pulley (See Fig. 28) and slip the belt out.
- Engage the auger drive lever. This will pull the brake assembly (See Fig. 27) away from the pulley and allow the belt to be slipped out.
- Remove the belt from the auger drive engine pulley.
- Install the original equipment replacement belt in reverse order of removal.
- Release the auger drive lever.
- Place the drive belt onto the auger drive pulley.
- Adjust the drive belt (see To Adjust Auger Drive Belt paragraph on page 18).
- Adjust the belt guides (see To Adjust The Belt Guides paragraph on page 20).
- Reinstall the belt cover.
- Check clutch control cable adjustment (see page 18).
- Reconnect the spark plug wire.

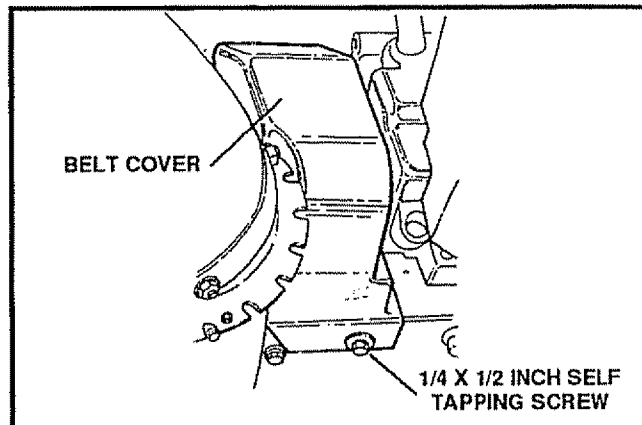

FIG. 26

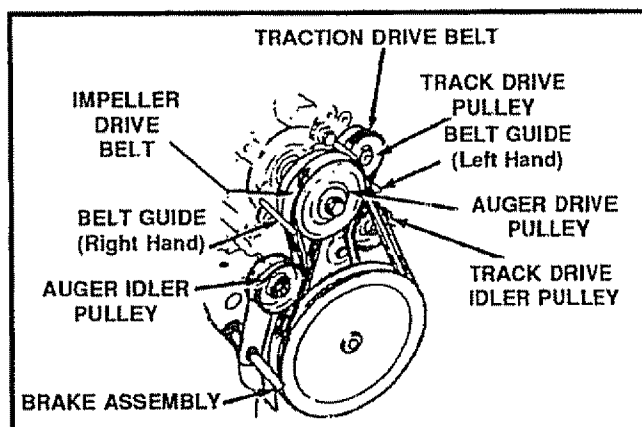

FIG. 27

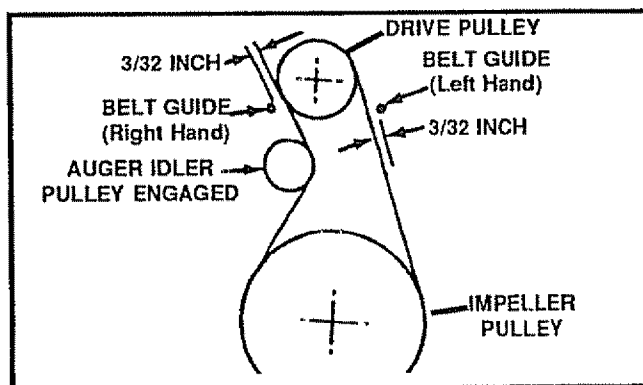

FIG. 28

SERVICE AND ADJUSTMENTS

TRACK DRIVE BELT

If your snow thrower will not move forward, check the track drive belt for wear. If the track drive belt needs to be replaced, proceed as follows:

- Disconnect the spark plug wire.
- Remove the belt cover.
- Loosen the left hand belt guide (See Fig. 27) mounting screw and move the belt guide away from the belt.
- Pull the track drive idler pulley (See Fig. 27) back and slip the belt past the idler pulley.
- Remove the belt from the engine pulley.
- Remove the belt between the two large pulleys.
- Install the new original equipment replacement belt in reverse order of removal.
- Adjust the left hand belt guide and tighten the mounting screw (see To Adjust The Belt Guides paragraph below).
- Reinstall the belt cover.
- Reconnect the spark plug wire.

TO ADJUST THE BELT GUIDES

There are two belt guides on your snow thrower, a left and right. After you replace a track or auger drive belt, you need to adjust one or both of the belt guides. Proceed as follows for each belt:

- Disconnect the spark plug wire.
- Remove the belt cover (See Fig. 26)
- Engage the auger drive clutch lever.
- Measure the distance between the belt guides and the belt (See Fig. 28). The distance should be $3/32$ " for each guide.
- If adjustment is necessary, loosen the belt guide mounting bolts. Move the belt guides to the correct position. Tighten the mounting bolts.
- Reinstall the belt cover.
- Reconnect the spark plug wire.

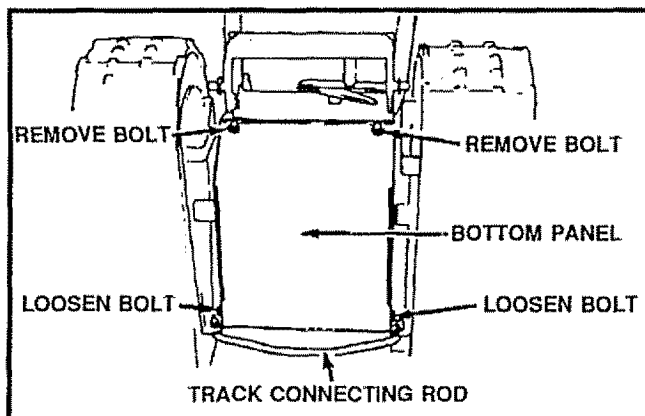

FIG. 29

TO ADJUST THE FRICTION WHEEL

If the snow thrower will not move forward, you need to check the track drive belt, the traction drive cable or the friction wheel. If the friction wheel is damaged, it will need to be replaced. See the To Replace Friction Wheel paragraph on page 21. If the friction wheel is not worn, check the adjustment, as follows:

- Disconnect the spark plug wire.
- Drain the gasoline from the gas tank.
- Stand snow thrower on the auger housing end.
- Remove the bottom panel (See Fig. 29).
- Position the shifter lever in first (1) gear.
- Note the position of the friction wheel on the disc drive plate. The right side of the friction wheel should be $3-3/8$ " from the left outer side of the disc drive plate (See Fig. 30).

If adjustment is necessary:

- Loosen the jam nut "A" on the speed select rod. Remove the ball joint from the shifter bracket. Lengthen or shorten the rod by turning the adaptor to obtain the correct friction wheel position (See Fig. 31)
- Reinstall the ball joint and tighten the jam nut.
- Reinstall the bottom panel.

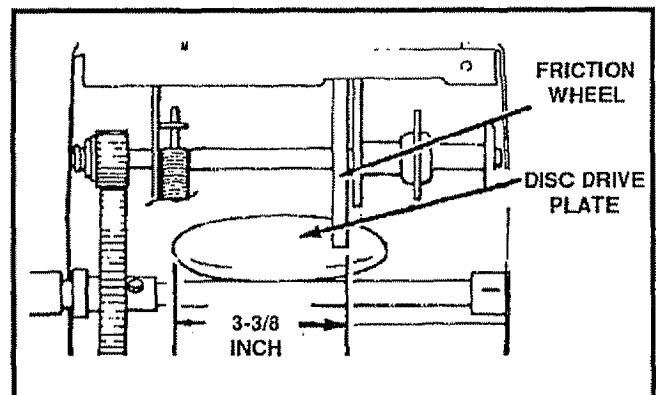

FIG. 30

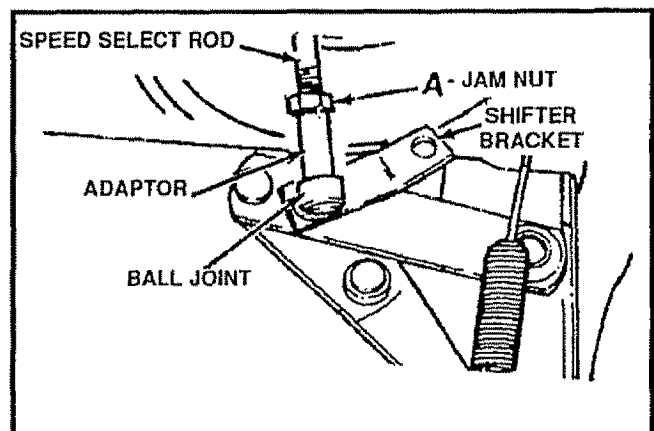

FIG. 31

SERVICE AND ADJUSTMENTS

TO REPLACE FRICTION WHEEL

If the snow thrower will not move forward, and the friction wheel is worn or damaged, you need to replace it, as follows:

- Drain the gasoline from the fuel tank by removing the fuel line. Drain the fuel and reinstall the fuel line.
- Disconnect the spark plug wire.
- Stand the snow thrower up on the auger housing end (See Fig. 32).
- Remove the bottom panel (See Fig. 29).
- Disconnect the right side track connecting rod.
- Rotate the right side track until it is parallel to the ground (See Fig 33).
- Remove the three (3) fasteners securing the friction wheel to the hub (See Fig. 32).



CAUTION: DRAIN GASOLINE OUTDOORS AWAY FROM FIRE OR FLAME.

- Move the shifter lever into first (1) gear.
- Loosen the four No. 10 keps nuts securing the bearing plate (See Fig. 33). Do not remove the nuts.

NOTE: Reassembly will be easier if you place a piece of tape over each of the carriage bolt heads on the inside of the motor mount before you remove the nuts.

- Move the speed select lever into sixth (6) gear.
- Remove the four No. 10 keps nuts.
- Remove the bearing plate.
- Slide the hex shaft to the right until the friction wheel can be removed.
- Install the new friction wheel loosely on the hex shaft.
- Reinstall the removed parts in reverse order of removal.

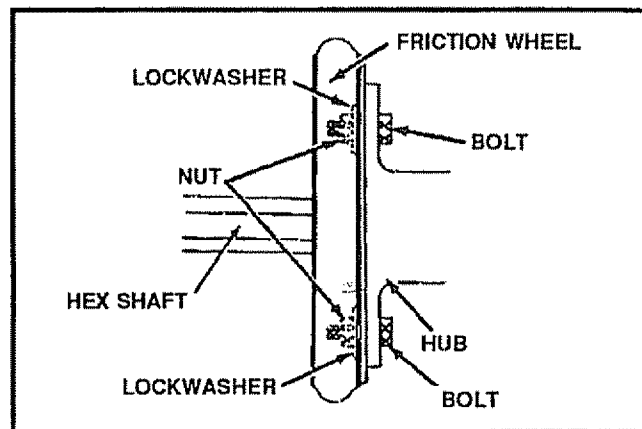

FIG. 32

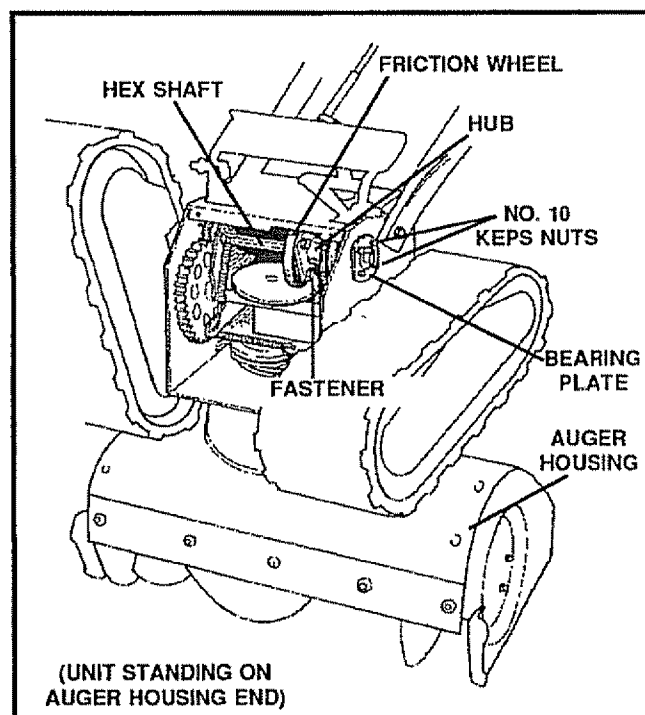

FIG. 33

SERVICE AND ADJUSTMENTS

TO REPLACE AUGER SHEAR BOLT

The augers are secured to the auger shaft with special bolts (See Fig. 34) that are designed to break (to protect the machine) if an object becomes lodged in the auger housing. Use of a harder bolt will destroy the protection provided by the shear bolt.

IMPORTANT: TO INSURE SAFETY AND PERFORMANCE LEVELS, ONLY ORIGINAL EQUIPMENT SHEAR BOLTS SHOULD BE USED. WHEN REPLACING SHEAR BOLTS, BE SURE TO REPLACE SHEAR BOLT SPACERS.

To replace a broken shear bolt, proceed as follows:

- Move the throttle to STOP and turn off all controls.
- Disconnect the spark plug wire. Be sure all moving parts have stopped.
- Lubricate the auger shaft zerk fitting (see the Maintenance section, pages 15-16).
- Align the hole in the auger with the hole in the auger shaft. Install the new shear bolt and shear bolt spacer provided.
- Reconnect the spark plug wire.

TO ADJUST TRACK

If the snow thrower does not move forward evenly and the track slips slightly, you need to check the track, as follows:

- Measure the distance between the top of the side plate and the inside of the track. The distance should not be more than two (2) inches.

If the distance is greater, you need to adjust the track, as follows:

- Loosen the bolts (A) (See Fig. 35) on both sides of the track assembly.
- Turn the cam washers equally on both sides.
- Adjust the track to reduce slack, so that the distance between the top of the side plate and the inside of the track is not greater than two (2) inches. Be sure the cam washers are adjusted evenly or the track will be twisted (See Fig. 36). If the track becomes twisted, readjust the cam washers to the correct adjustment.

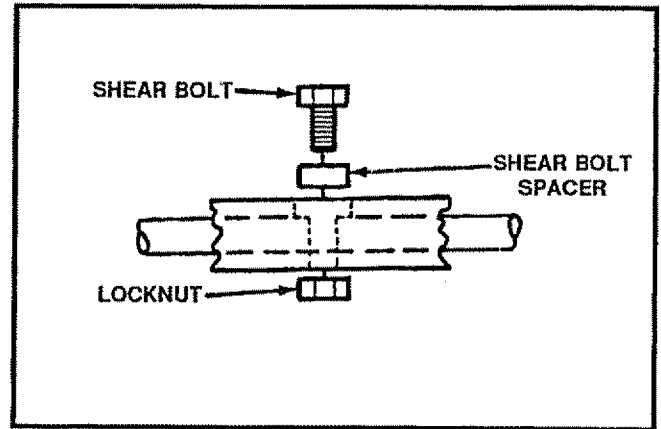

FIG. 34

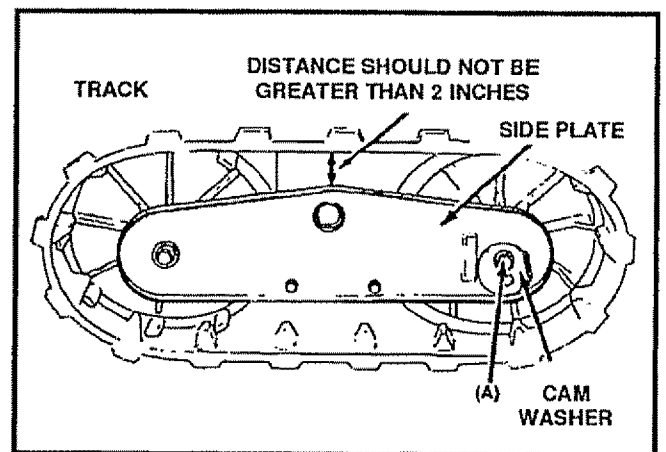

FIG. 35

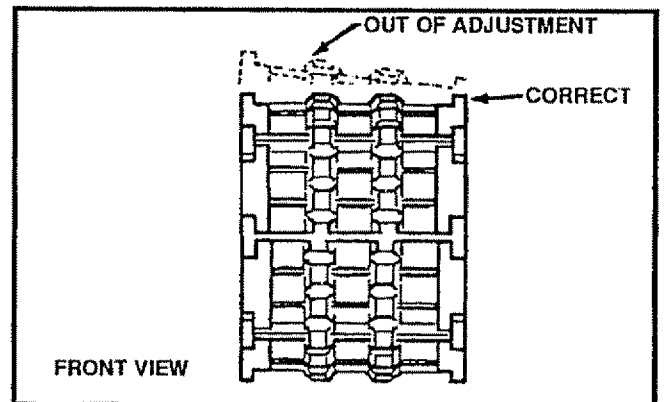

FIG. 36

SERVICE AND ADJUSTMENTS

TO ADJUST CARBURETOR

The carburetor (See Fig. 37) has been pre-set at the factory and readjustment should not be necessary. However, if the carburetor does need to be adjusted, proceed as follows:

- Close the high speed adjusting screw by hand.
- Do not overtighten.
- Then open it 1-1/4 to 1-1/2 turns.
- Close the idle adjusting screw by hand. Do not overtighten.
- Then open it 1-1/4 to 1-1/2 turns.
- Start the engine and let it warm up.
- Set the throttle control to FAST. Adjust the high speed adjusting screw **in** until the engine speed or sound alters. Adjust the screw **out** until the engine speed sound alters. Note the difference between the two limits and set the screw in the middle of the range.
- Set the throttle control to SLOW. Adjust the idle adjusting screw **in** until the engine speed drops, then adjust the screw **out** until the engine speed drops. Note the difference between the two limits and set the screw in the middle of the range.
- If the engine tends to stall under load or not accelerate from low speed to high speed properly, adjust the high speed screw out in 1/8 turn increments until the problem is resolved.
- Let the engine run undisturbed for 30 seconds between each setting to allow the engine to react to the previous adjustments.

IMPORTANT: NEVER TAMPER WITH THE ENGINE GOVERNOR, WHICH IS FACTORY SET FOR PROPER ENGINE SPEED. OVERSPEEDING THE ENGINE ABOVE THE FACTORY HIGH SPEED SETTING CAN BE DANGEROUS. IF YOU THINK THE ENGINE - GOVERNED HIGH SPEED NEEDS ADJUSTING, CONTACT YOUR NEAREST SEARS SERVICE CENTER, WHICH HAS THE PROPER EQUIPMENT AND EXPERIENCE TO MAKE ANY NECESSARY ADJUSTMENTS.

TO ADJUST OR REPLACE THE SPARK PLUG

If you have difficulty starting your snow thrower, you may need to adjust or replace the spark plug. Follow the instructions below.

Replace the spark plug if electrodes are pitted or burned or if the porcelain is cracked

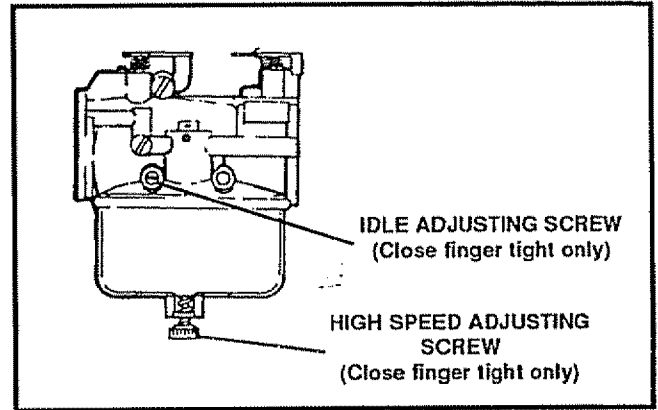

FIG. 37

TO ADJUST:

- Clean the spark plug by carefully scraping electrodes (do not sand blast or use a wire brush).
- Be sure the spark plug is clean and free of foreign material. Check electrodes gap (See Fig. 38) with a wire feeler gauge and reset the gap to .030 inch if necessary.

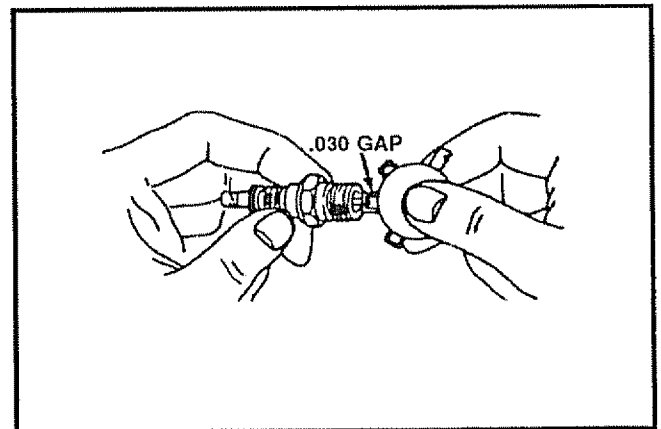

FIG. 38

TO REPLACE:

- If you need a new spark plug, use only the proper replacement spark plug.
- Set the gap to .030 (See Fig. 38).
- Before installing the spark plug, coat its threads lightly with graphite grease to insure easy removal.
- Tighten the plug firmly into the engine.
- If a torque wrench is available, torque the plug to 18 to 23 ft - lbs.

STORAGE



CAUTION: NEVER STORE THE ENGINE WITH FUEL IN THE TANK INDOORS OR IN AN ENCLOSED, POORLY VENTILATED AREA WHERE FUEL FUMES MAY REACH AN OPEN FLAME, SPARK OR PILOT LIGHT AS ON A FURNACE, WATER HEATER, CLOTHES DRYER, ETC.

NOTE: Immediately prepare your snow thrower for storage at the end of the season or if the unit will not be used for 30 days or more.

SNOW THROWER

- Thoroughly clean the snow thrower.
- Lubricate all lubrication points (see the Maintenance section, pages 15 -16).
- Be sure that all nuts, bolts and screws are securely fastened. Inspect all visible moving parts for damage, breakage and wear. Replace if necessary.
- Touch up all rusted or chipped paint surfaces; sand lightly before painting.
- Cover the bare metal parts of the blower housing auger and the impeller with rust preventative, such as sprayable lubricant.

NOTE: A yearly checkup or tuneup by a SEARS Service Center is a good way to insure that your snow thrower will provide maximum performance for the next season.

ENGINE

IMPORTANT: IT IS IMPORTANT TO PREVENT GUM DEPOSITS FROM FORMING IN ESSENTIAL FUEL SYSTEM PARTS SUCH AS THE CARBURETOR, FUEL FILTER, FUEL HOSE OR TANK DURING STORAGE. ALSO, EXPERIENCE INDICATES THAT ALCOHOL BLENDED FUELS (CALLED GASOHOL OR USING ETHANOL OR METHANOL) CAN ATTRACT MOISTURE WHICH LEADS TO SEPARATION AND FORMATION OF ACIDS DURING STORAGE. ACIDIC GAS CAN DAMAGE THE FUEL SYSTEM OF AN ENGINE WHILE IN STORAGE.

- Drain the gasoline from the fuel tank by removing the fuel line. Drain the fuel and reinstall the fuel line.



CAUTION: DRAIN FUEL INTO APPROVED CONTAINER OUTDOORS, AWAY FROM OPEN FLAME.

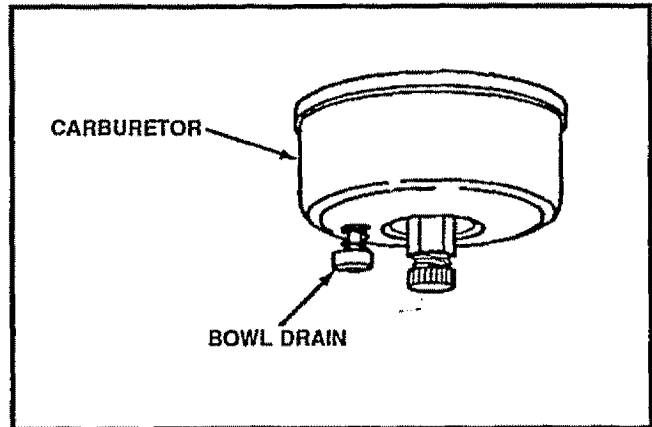

FIG. 39

- Start the engine and run at SLOW (idle) speed until the engine stops from lack of fuel.
- Drain the carburetor by pressing upward on the bowl drain (See Fig. 39), located below the carburetor cover.

NOTE: Fuel stabilizer (such as STA-BIL) is an acceptable alternative in minimizing the formation of fuel gum deposits during storage. Add stabilizer to gasoline in fuel tank or storage container. Always follow the mix ratio found on stabilizer container. Run engine at least 10 minutes after adding stabilizer to allow the stabilizer to reach the carburetor. Do not drain the gas tank and carburetor if using fuel stabilizer.

- Remove the spark plug and squirt one (1) ounce of engine oil into the cylinder. Pull the recoil starter rope slowly, allowing the piston to coat the internal engine parts. Install an old spark plug. This prevents fouling a new plug with the preservative used to lubricate the internal parts of the engine. Close the choke and plug the muffler opening.

OTHER

- If possible, store your snow thrower indoors and cover it to give protection from dust and dirt.
- If the machine must be stored outdoors, block up the snow thrower to be sure the entire machine is off the ground.
- Cover the snow thrower with a suitable protective cover that does not retain moisture. Do not use plastic.

IMPORTANT: NEVER COVER SNOW THROWER WHILE ENGINE AND EXHAUST AREAS ARE STILL WARM.

SERVICE RECOMMENDATIONS

SERVICE RECORDS Fill in dates as you complete regular service	SCHEDULE							SERVICE DATES			
	After First 2 hours	Before Each Use	Often	Every 10 Hours	Every 25 Hours	Each Season	Before Storage				
Check Engine Oil Level		✓				✓					
Change Engine Oil	✓				✓	✓					
Tighten All Screws and Nuts	✓	✓	✓								
Check Traction Clutch Cable Adjustment (See Cable Adjustment)	✓					✓					
Replace Spark Plug					✓	✓					
Adjust Drive Belts	✓				✓	✓					
Lubricate All Pivot Points				✓			✓				
Lubricate Auger Shaft (See Shear Bolt Replacement)							✓				
Lubricate Sprockets and Chains Sparingly (Track Assembly)				✓			✓				
Drain Fuel							✓				
Check Auger Clutch Cable Adjustment (See Cable Adjustment)	✓					✓					

LUBRICATION CHART

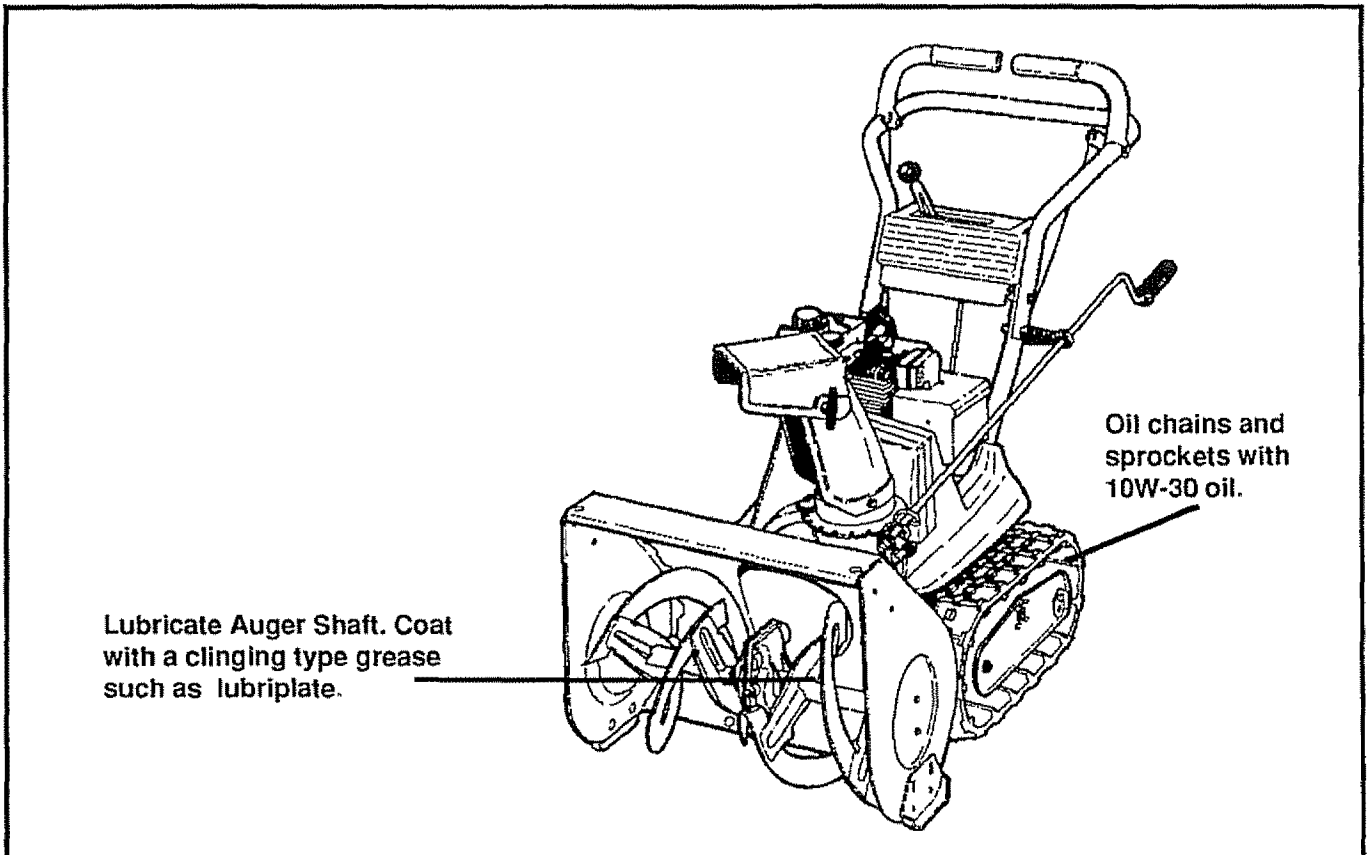

TROUBLE SHOOTING POINTS

TROUBLE	CAUSE	CORRECTION
Difficult starting	Defective spark plug Water or dirt in fuel system	Replace defective plug. Use carburetor bowl drain to flush and refill with fresh fuel.
Engine runs erratic	Blocked fuel line or low on fuel	Clean fuel line; check fuel supply; add fresh gasoline (Gasoline/oil mixture if 2 cycle engine.)
Engine stalls	Unit running on CHOKE	Set choke lever to RUN position.
Engine runs erratic; Loss of power	Water or dirt in fuel system Carburetor out of adjustment	Use carburetor bowl drain to flush and refill with fresh fuel Adjust carburetor.
Excessive vibration	Loose parts; damaged impeller	Stop engine immediately and disconnect spark plug wire Tighten all bolts and make all necessary repairs. If vibration continues, have the unit serviced by a competent repairman.
Unit fails to propel itself	Drive belt loose or damaged Incorrect adjustment of traction drive cable Worn or damaged friction wheel	Replace drive belt Adjust traction drive cable. Replace friction wheel.
Unit fails to discharge snow	Auger drive belt loose or damaged Auger control cable not adjusted correctly Shear bolt broken Discharge chute clogged Foreign object lodged in auger	Adjust auger drive belt; replace if damaged Adjust auger control cable. Replace shear bolt Stop engine immediately and disconnect spark plug wire. Clean discharge chute and inside of auger housing Stop engine immediately and disconnect spark plug wire. Remove object from auger.
Unit rides up	Weight transfer disengaged	Engage weight transfer pedal.

NOTES

CRAFTSMAN 23" SNOW THROWER 536.884811

REF. NO.	PART NO.	PART NAME	REF. NO.	PART NO.	PART NAME
1	3535	5/16 In. Cap Nut	33	71457	Eye Bolt
2	309344	Adapter, Boot to Handle	34	70984	5/16-18 x 3/4 In. Screw
3	3538	Pivot Pin	35	308011	Lower Handle
4	4049	Bumper	36	1672	Drive Clutch Spring
5	308012	Upper Handle	37	1673	Auger Clutch Spring
6	70990	5/16-18 x 1-3/4 In. Screw	38	71035	1/4-20 Locknut
7	309059	Bracket, Chute Rotate Stop	39	304872	Retainer Ring
8	308037	Shift Lever	40	307399	Chute Crank Handle
9	6300	Decal, Gear Selector	41	17	Chute Crank Assembly
10	71059	1/4 In. Lockwasher	42	148	Eye Bolt Grommet
11	71034	1/4-20 Hex Nut	43	71082	3/32 x 1 In. Cotter Pin
12	306523	Control Panel	44	104	Plastic Cap
13	310421	Support Control Panel Ass'y	45	7055	Chute Control Rod
14	308901	Taptite Screw, 10-24 x 5/8 In.	46	7058	1/2-20 Jam Nut
15	310391	1/4-20 x 2 In. Carriage Bolt	47	7059	1/2 In. Lockwasher
16	71042	5/16-24 Hex Nut	48	70993	5/16-18 x 3/4 In. Carriage Bolt
17	71060	5/16 In. Lockwasher	49	7052	L.H. Chute Rotate Bracket
18	50782	Ball Joint	50	1162	R.H. Chute Rotate Bracket
19	6352	Adapter, Speed Control Rod	51	71037	5/16-18 Hex Nut
20	50786	Spring	52	71071	11/32 In. Flatwasher
21	71072	13/32 In. Flatwasher	53	71007	3/8-16 x 2 In. Hex Hd Bolt
22	71038	5/16-18 Hex Nut	54	3903	Auger Drive Control Decal
23	1668	Speed Control Rod	55	3902	Traction Drive Control Decal
24	1449	Lever, Speed Control	56	308146	Clutch Spring Boot
25	73801	5/32 x 7/8 In. Spring Pin	57	308145	Eyebolt Boot
26	73812	1/2 In. Flatwasher	58	50780	Plastic Knob
27	1579	Clutch Cable	59	307920	Traction Drive Lever, L. H.
28	7288	3/8-16 x 3 In. Screw	60	307918	Auger Drive Lever, R. H.
29	71062	3/8 In. Lockwasher	61	309310	Plug, Nylon
30	71044	3/8-16 Hex Nut	62	309312	Washer, Flat
31	7289	Plastic Stop	63	71046	3/8" Nylon Locknut
32	71045	3/8-16 Jam Nut	64	307148	Owner's Manual

CRAFTSMAN 23" SNOW THROWER 536.884811

Motor Mount Assembly Repair Parts

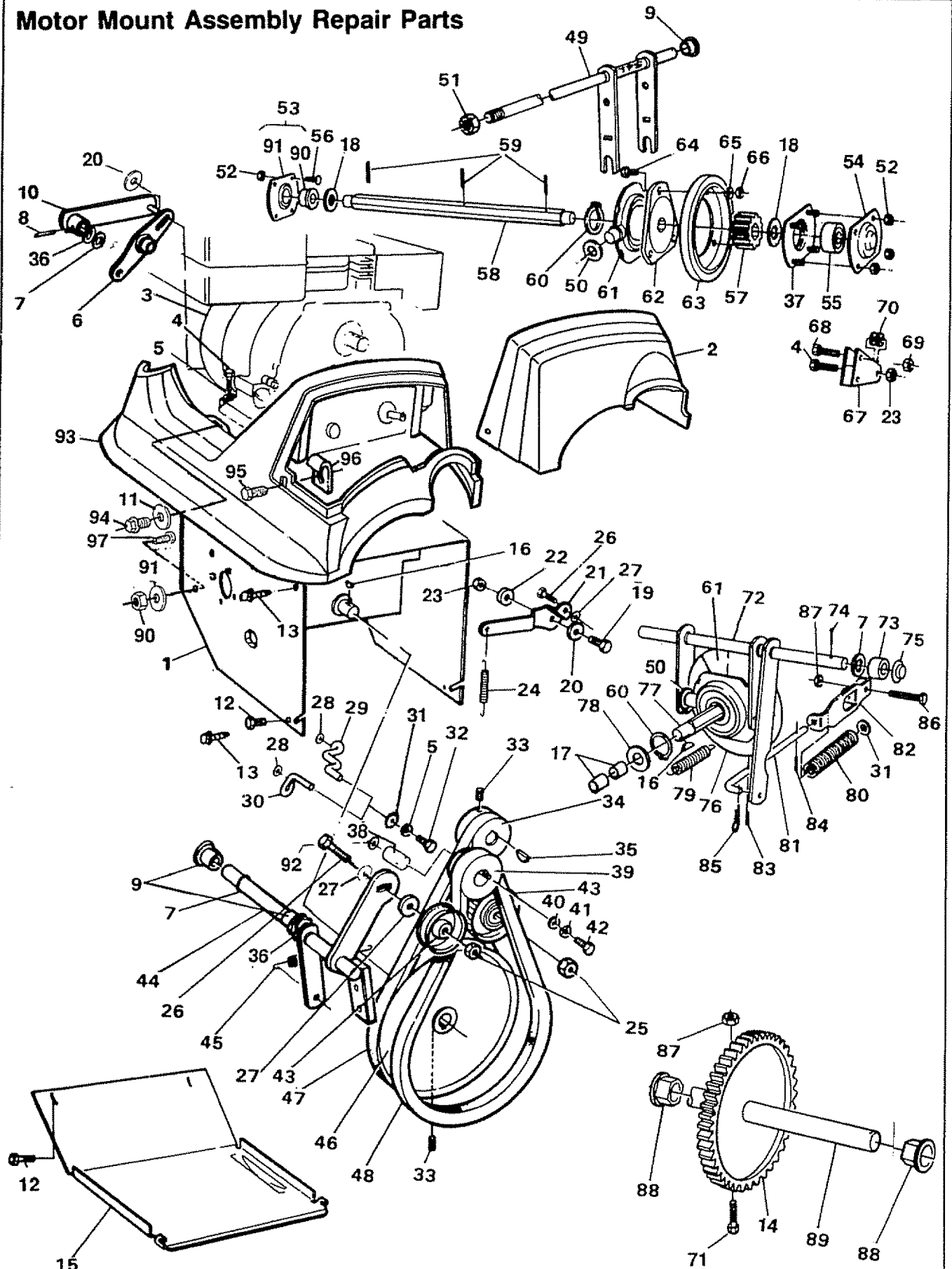

CRAFTSMAN 23" SNOW THROWER 536.884811

REF. NO.	PART NO.	PART NAME	REF. NO.	PART NO.	PART NAME
1	308646	Motor Mount Frame	50	73812	1/2 In. Flatwasher
2	307696	Belt Cover	51	71111	3/8-16 Hex Locknut
3	308054	Tecumseh Engine, 5 H.P., 4 Cy.	52	71461	#10-24 Keps Nut
4	70988	5/16-18 x1-1/4 In. Bolt	53	85504	Bearing Assembly
5	71060	5/16 In. Lockwasher	54	6105	Inner Bearing Retainer
6	85494	Clutch Cable Lever	55	6107	Ball Bearing
7	71074	1/2 In. Flatwasher	56	72531	10-24 x 3/8 In. Carriage Bolt
8	73801	5/32 x 7/8 In. Spring Pin	57	53833	8 Tooth Pinion Gear
9	53703	Bushing, Plastic	58	53832	Hex Disc Friction Wheel Shaft
10	85492	Clutch Auger Lever Assembly	59	71086	1/8 x 3/4 In. Spring Pin
11	71067	1/4 In. Flatwasher	60	73811	1/4 In. Snap Ring
12	70978	1/4-20 x 1/2 In. Self Tapping Screw	61	85501	Trunion Bearing
13	70982	5/16-18 x 1/2" Self Tapping Screw	62	53831	Friction Wheel Hub
14	6215	48 Tooth Gear	63	53830	Friction Wheel
15	308009	Bottom Cover	64	11871	1/4-20 x 5/8 In. Bolt
16	50795	3/4 In. Hypro Key	65	71059	1/4 In. Split Lockwasher
17	7287	Roller Bearing	66	71034	1/4-20 Hex Nut
18	6106	1/2 In. Flatwasher	67	308005	Pivot Bracket
19	70985	5/16-18 x 3/4 In. Bolt	68	71360	1/4-20 x 1-3/4 In Bolt
20	73795	5/16 x 1-3/8 In. Flatwasher	69	71035	1/4-20 Hex Locknut
21	53793	Idler Traction Lever	70	51438	5/16 In. Spacer, Sleeve
22	53794	Spacer, Sleeve	71	73839	1/4-20 x 2-1/4 In. Bolt
23	71391	5/16-18 Hex Locknut	72	85499	Traction Shaft Assembly
24	53704	Idler Traction Drive Spring	73	53816	1/2 In. Spacer, Sleeve
25	590	3/8-16 Hex Jam Nut	74	71079	1/8 x 1 In. Cotter Pin
26	71010	3/8-16 x 1-1/2 In. Bolt	75	73817	1/2 In. Push-on Nut
27	71072	3/8 In. Flatwasher	76	53807	Friction Wheel Disc
28	73787	Belt Retainer Washer	77	7091	Traction Hex Shaft
29	55026	L.H. Belt Guide	78	7286	Thrust Bearing
30	55027	R.H. Belt Guide	79	53818	Return Spring
31	71071	11/32 In. Flatwasher	80	53820	Clutch Spring
32	71393	5/16-24 x 1 In. Bolt	81	53821	Clutch Rod
33	577399	5/16-18 x 1/2 In. Set Screw	82	53819	Traction Spring Bracket
34	53788	Engine Pulley	83	73823	1/8 x 1-3/8 In. Spring Pin
35	20579	Key, Woodruff # 5	84	73822	1/8 x 1/2 In. Spring Pin
36	30289	1/2 In. Wave Washer	85	71081	3/32 x 3/4 In. Cotter Pin
37	6103	Outer Bearing Retainer	86	70970	1/4-20 x 1-1/4 In. Bolt
38	577269	Engine Pulley Spacer	87	73826	1/4-20 Hex Locknut
39	53714	Engine Drive Pulley	88	53836	Shaft Hex Bearing
40	50677	Flatwasher	89	5923	Track Axle Shaft
41	71063	3/8 In Lockwasher	90	71045	Nut, 3/8-16
42	71015	3/8-24 x 1 In. Bolt	91	71062	Washer, Splitlock
43	50793	1-7/8 In. Idler Pulley	92	48275	Washer, Flat 3/4 In.
44	1451	Shaft & Levers Assembly	93	307697	Fender
45	443	Auger Brake Spring	94	310169	Screw, 1/4-20 x 3/8 In.
46	301545	5 In. Impeller Pulley	95	308900	Screw, 14-10 x 3/4 In.
47	5939	Special Traction Drive Belt	96	308903	Nut, 14-10 "J" Type
48	3526	Special Auger Drive Belt	97	71005	Screw, 3/8-16 x 1 In.
49	85495	Shift Control Shaft			

CRAFTSMAN 23" SNOW THROWER 536.884811

Track Assembly Repair Parts

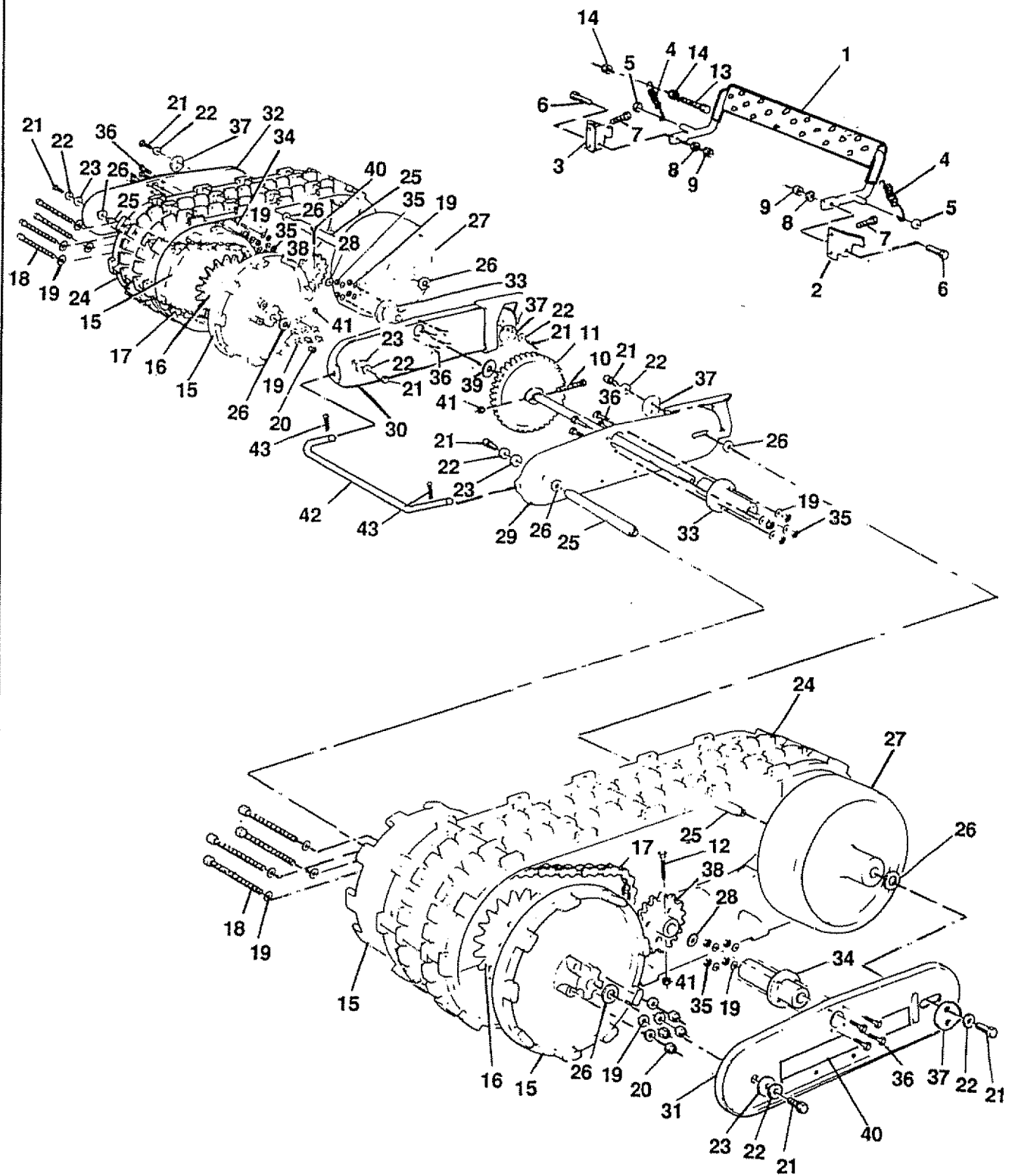

CRAFTSMAN 23" SNOW THROWER 536.884811

REF. NO.	PART NO.	PART NAME
1	308048	Foot Pedal
2	308038	L.H. Bracket, Weight Transfer
3	308039	R.H. Bracket, Weight Transfer
4	6025	Tension Spring
5	518	1/2 In. Pal Nut
6	6001	7/16 In. Shoulder Bolt
7	70978	1/4-20 x 1/2 In. Self Tapping Screw
8	71060	5/16 In. Lockwasher
9	71037	5/16-18 Hex Nut
10	73839	1/4-20 x 2-1/4 In. Screw
11	6215	48 Tooth Gear
12	7285	Screw, 1/4-20 x 1-1/2 In.
13	70985	5/16-18 x 3/4 In. Bolt
14	71391	5/16-18 Hex Locknut
15	301818	Track Drive Wheel
16	5930	Sprocket
17	5917	Chain #420-50
18	5947	1/4-28 x 3-3/4 In. Screw
19	71067	1/4 In. Flatwasher
20	6108	1/4-28 Locknut
21	71348	5/16-18 x 1/2 In. Screw
22	5951	5/16 In. Belleville Washer

REF. NO.	PART NO.	PART NAME
23	5950	1/2 In. Flatwasher
24	9724	4-3/4 In. Track
25	302024	Track Wheel Shaft
26	7074	1/2 In. Flatwasher
27	301817	Track Idler Wheel
28	305299	3/4 In. Flatwasher
29	308883	Inner L.H. Track Plate
30	308882	Inner R.H. Track Plate
31	308061	Outer L.H. Track Plate
32	308056	Outer R.H. Track Plate
33	9756	Inner Track Bearing Hub
34	301819	Outer Track Bearing Hub
35	71035	1/4-20 Hex Locknut
36	70969	1/4-20 x 1 In. HHC Screw
37	6403	Cam Washer
38	304133	Sprocket and Hub Assembly
39	73840	3/4 In. Flatwasher
40	308784	Trac Plus Decal
41	73826	1/4-20 Locknut
42	9727	Tie Rod
43	20465	1/8 In. Hair Pin



CRAFTSMAN 23" SNOW THROWER 536.884811

Auger Housing Assembly Repair Parts

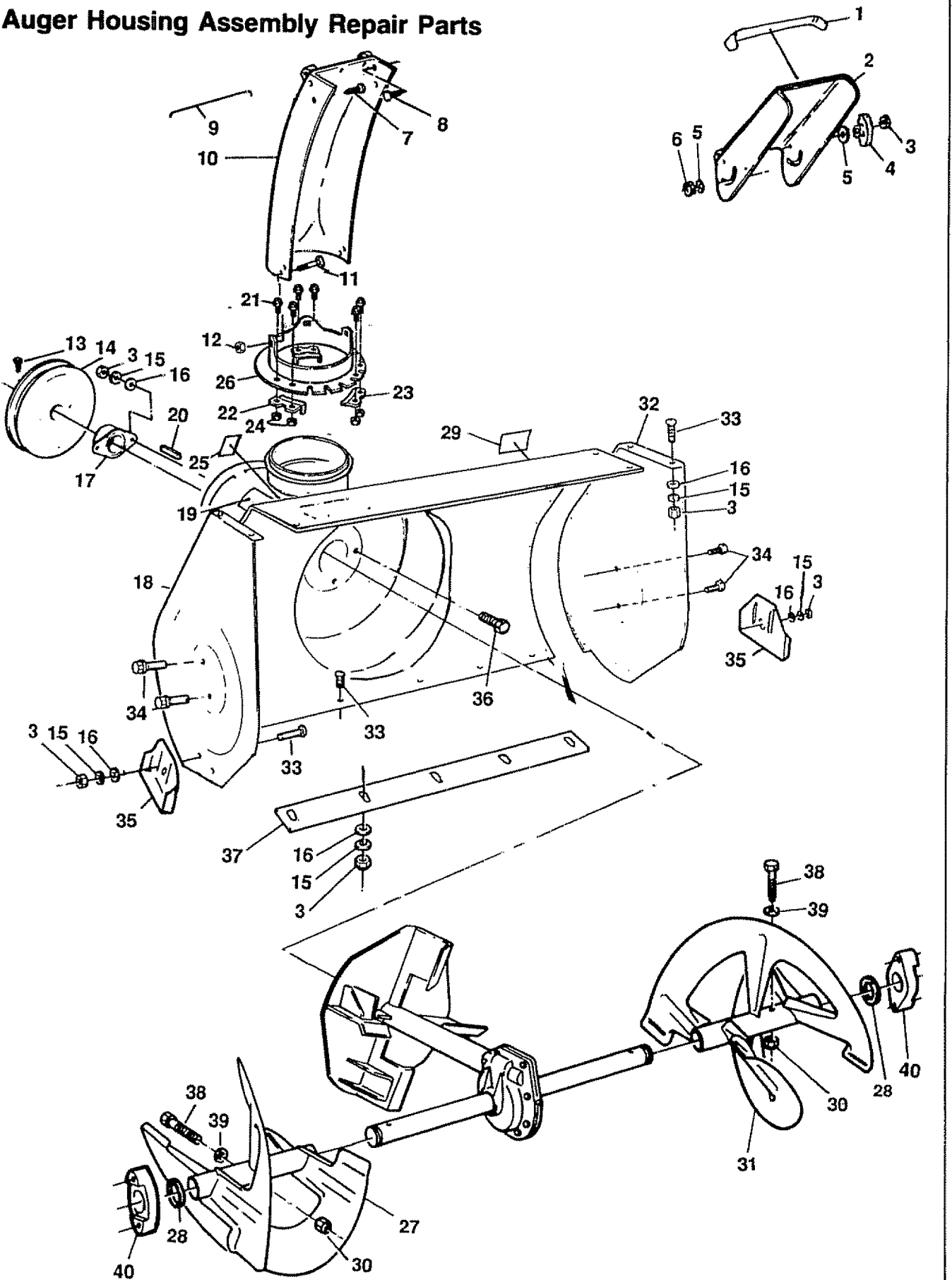

CRAFTSMAN 23" SNOW THROWER 536.884811

REF. NO.	PART NO.	PART NAME	REF. NO.	PART NO.	PART NAME
1	308768	Striped Danger Decal	21	71032	8-32 x 1/2 In. Bolt
2	307665	Chute	22	309057	Retainer w/ Stop Clip,Chute
3	71037	5/16-18 Hex Nut	23	85480	Lower Chute Ring Clip
4	57171	Wing Knob	24	71058	#8-32 Hex Locknut
5	302680	5/16 In. Flatwasher	25	70142	Chute Danger Decal
6	71391	5/16-18 Hex Locknut	26	308839	Lower Chute Ring
7	302843	5/16-18 x 1-1/4 In. Carriage Bolt	27	308053	R.H. Auger
8	302634	5/16-18 x 3/4 In. Screw	28	73755	Auger Washer
9	308931	Chute Hinge Wire	29	70141	Auger Danger Decal
10	307698	Lower Chute	30	73826	1/4-20 Locknut
11	302678	1/4-20 x 1/2 In. Screw	31	308052	L.H. Auger
12	302635	1/4-20 Wide Flange Locknut	32	308118	L.H. Side Plate
13	577400	5/16-18 x 3/4 In. Bolt	33	70993	5/16-18 x 3/4 In. Carriage Bolt
14	53759	6.5 In. Auger Pulley	34	70984	5/16-18 x 3/4" Self Tapping Screw
15	71060	5/16 In. Split Lockwasher	35	307912	Height Adjust Skid
16	71071	11/32 In. Flatwasher	36	70983	5/16-18 x 5/8 In. Screw
17	308059	Bearing & Retainer	37	736	Scraper Bar
18	308119	R.H. Side Plate	38	9524	1/4-20 x 1-3/4 In. HHC Screw
19	302922	Danger Decal, Read From Side	39	3943	1/4 In. Spacer
20	20556	3/16 In. Square Key	40	53757	1 In. Auger Shaft Bearing

CRAFTSMAN 23" SNOW THROWER 536.884811

GEAR BOX REPAIR PARTS

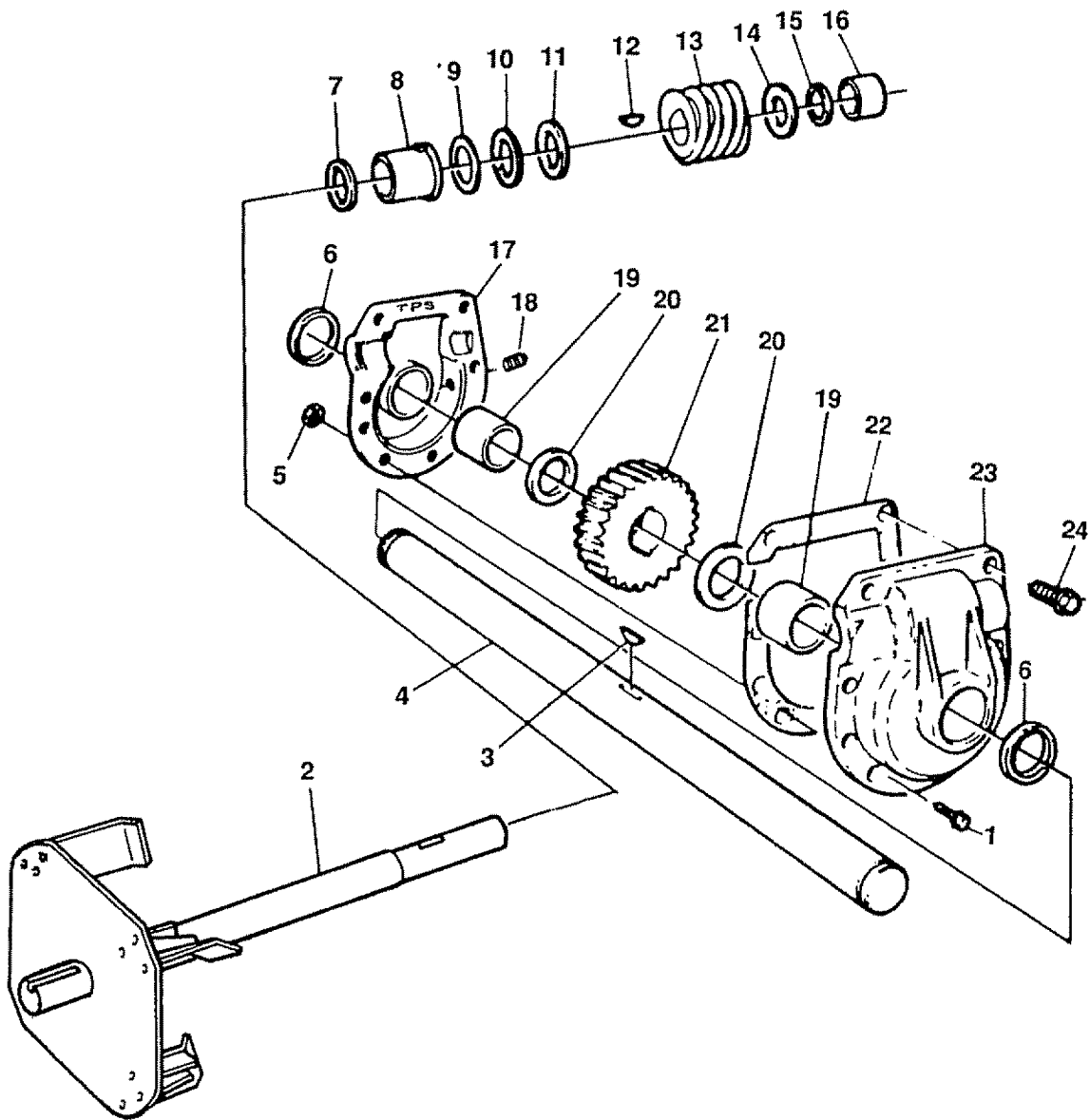

REF. NO.	PART NO.	PART NAME
1	71393	5/16-24 X 1 In. Bolt
2	308051	Impeller & Shaft Assembly
3	73905	Woodruff Key #91
4	3956	Auger Shaft, 23 In.
5	71100	5/16-24 Flange Locknut
6	1065	Oil Seal
7	53737	Quad Ring
8	10905	Flange Bearing
9	53735	7/8 In. Flatwasher
10	53734	7/8 In. Roller Bearing
11	53733	7/8 In. Flatwasher
12	50795	3/4 In. Key

REF. NO.	PART NO.	PART NAME
13	53732	1-3/4 In. Worm Gear
14	50683	3/4 In. Flatwasher
15	50688	Retaining Ring
16	53731	Sleeve Bearing
17	895	L.H. Gear Box Housing
18	53749	1/4 x 18 Pipe Plug
19	53743	Auger Gear Box Bearing
20	53748	1 In. Flatwasher
21	53730	Worm Gear
22	897	Gear Box Gasket
23	896	R.H. Gear Box Housing
24	912	5/16-24 x 1-1/2 In. Bolt



REWIND STARTER NO. 590646

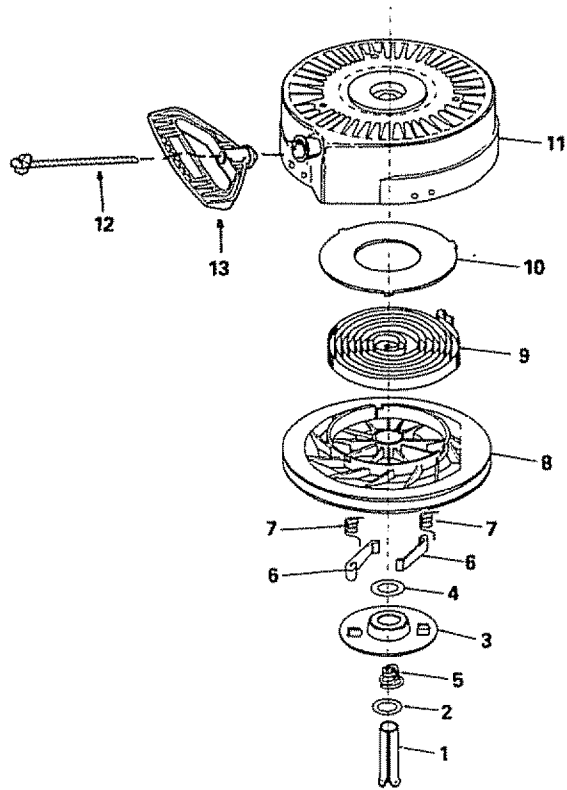

Ref. No.	Part No.	Part Name
	590646	Starter, Rewind
1	590599A	Pin, Spring (Incl. No. 4)
2	590600	Washer
3	590615	Retainer
4	590601	Washer
5	590598	Spring, Brake
6	590616	Dog, Starter
7	590617	Spring, Dog
8	590645	Pulley
9	590619	Spring, Rewind
10	590620	Cover, Spring
11	590647	Housing Assy., Starter
12	590451A	Rope, Starter (Length 69" & 5/32" dia.)
13	590574	Handle, Mitten Grip (Not included with starter)



CRAFTSMAN 4-CYCLE ENGINE

MODEL NUMBER: 143.804072

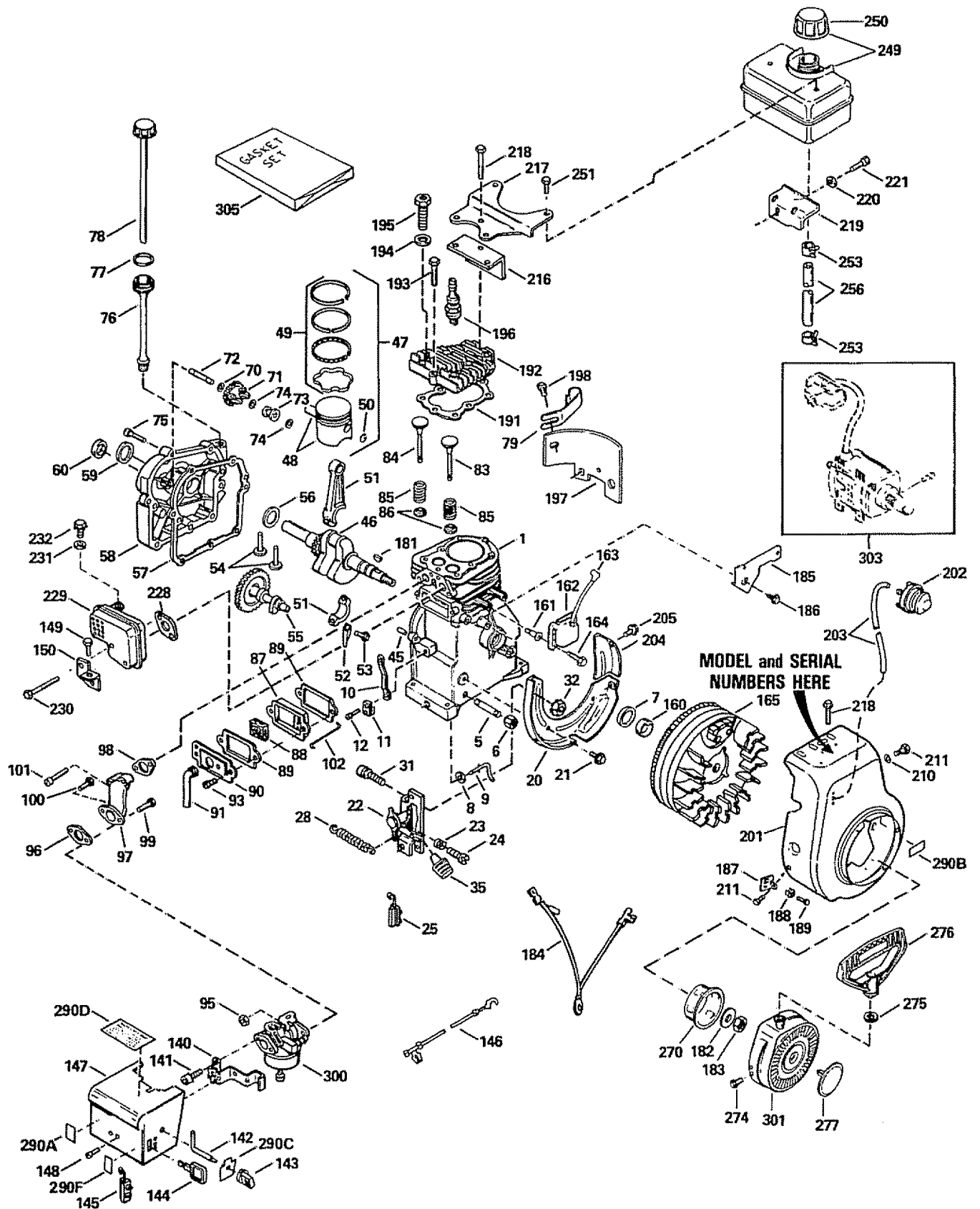

CRAFTSMAN 4-CYCLE ENGINE

MODEL NUMBER: 143.804072

Ref. No.	Part No.	Part Name	Ref. No.	Part No.	Part Name
1	33674B	Cylinder Assy. (Incl. Nos. 7 & 45)	91	35350	Tube, Breather
5	34171	Nipple, Pipe	93	650128	Screw, Hex hd. Sems, 10-24 x 1/2
6	30969	Cap, Oil drain	95	29752	Nut & Lockwasher, 1/4-28
7	32600	Seal, Oil	96	*26756	Gasket, Carburetor
8	28277	Washer, Flat	97	33691	Pipe, Intake
9	31334	Rod, Governor	98	*33673A	Gasket, Intake
10	31510	Lever, Governor	99	6201	Screw, Hex hd., 1/4-28 x 7/8
11	31335	Clamp, Governor lever	100	650870	Screw, Hex hd., 1/4-28 x 1-11/16
12	650548	Screw, Hex washer hd., 8-32 x 5/16	101	650664	Screw, Fil. hd. Sems, 1/4-20 x 1-19/32
20	133342	Baffle, Blower housing	102	32698	Link, Governor to throttle
21	650561	Screw, Hex washer hd. Durluk, 1/4-20 x 5/8	140	34583	Bracket, Choke
22	133838A	Control Assy., Bracket (Incl. Nos. 23 thru 25, 31 & 32)	141	28820	Screw, Fil. hd. Sems, 10-32 x 1/2
23	31342	Spring, Compression	142	34582	Rod, Choke
24	650549	Screw, Fil. hd., 5-40 x 7/16	143	35438	Knob, Choke control
25	610973	Terminal Assy.	144	35593	Key, Ignition
28	31426	Spring, Extension	145	610973	Terminal Assy.
31	1650139	Screw, Fil. hd. Sems, 8-32 x 1/2	146	35285	Wire, Ground
32	130322	Nut, Lock, 8-32	147	35072	Cover, Carburetor
35	35440	Knob, Speed control	148	650257	Screw, Pan hd. Sems, 8-32 x 5/16
45	26727	Pin, Dowel	149	650735	Screw, Hex hd. Sems, taptite, 10-24 x 3/8
46	34740	Crankshaft Assy.	150	33333	Bracket, Carburetor cover
47	34535	Piston, Pin & Ring Assy. (Std.) (Incl. Nos. 48, 49 & 50)	160	34080	Spacer, Flywheel key
47	34536	Piston, Pin & Ring Assy. (.010 oversize) (Incl. Nos. 48, 49 & 50)	161	650872	Stud, Solid state mounting
47	34537	Piston, Pin & Ring Assy. (.020 oversize) (Incl. Nos. 48, 49 & 50)	162	34443A	Solid State Assy.
48	33562B	Piston & Pin Assy. (Std.) (Incl. No. 50)	163	610118	Cover, Spark plug
48	33563B	Piston & Pin Assy. (.010 oversize) (Incl. No. 50)	164	650814	Screw, Torx hex washer hd. Sems, 10-24 x 1
48	33564B	Piston & Pin Assy. (.020 oversize) (Incl. No. 50)	165	611081	Flywheel (w/ring gear)
49	33567	Ring Set, Piston (Std.)	181	610961	Key, Flywheel
49	33568	Ring Set, Piston (.010 oversize)	182	650815	Washer, Belleville
49	33569	Ring Set, Piston (.020 oversize)	183	650863	Nut, Flywheel
50	20381	Ring, Piston pin retaining	184	35557	Wire, Ground
51	32875	Rod Assy., Connecting (Incl. Nos. 52 & 53)	185	34212	Bracket, Hold down
52	32654	Dipper, Oil	186	30200	Screw, Hex washer hd. self-tap Sems, 10-24 x 9/16
53	32610A	Bolt, Connecting rod	187	34126	Bracket, Grommet mounting
54	27241	Lifter, Valve	188	28545	Grommet, Plastic
55	33696	Camshaft (Compression Release)	189	650760	Screw, Pan hd. taptite, 8-32 x 3/8
56	32323	Washer, Thrust	191	*33554A	Gasket, Cylinder head
57	*27677A	Gasket, Cylinder cover	192	33016A	Head, Cylinder (Incl. No. 218)
58	34678	Cover, Cylinder (Incl. Nos. 59, 60 & 72)	193	6021A	Screw, Hex flange hd., 5/16-18 x 1-1/2
59	27897	Seal, Oil	194	650691	Washer, Flat
60	30318	Seal, Camshaft	195	650818	Screw, Special hex hd., 5/16-18 x 1-1/2
70	35479	Washer, Flat	196	33636	Plug, Spark (Champion J-8C or equivalent)
71	30591	Gear, Governor (Incl. No. 70)	197	29745	Extension, Blower housing
72	30574	Shaft, Mechanical governor	198	650128	Screw, Hex hd. Sems, 10-24 x 1/2
73	30588A	Spool, Governor	201	35656	Housing, Blower
74	29193	Ring, Retaining	202	570682	Primer Assy.
75	650488	Screw, Hex hd. Sems, 1/4-20 x 1-1/4	203	32180C	Line, Primer
76	35554	Tube Assy., Oil fill	204	33341	Extension, Baffle
77	35499	"O" Ring	205	650701	Screw, Hex washer hd. shakeproof self-drilling, 8-18 x 7/16
78	35556	Dipstick	210	650168	Washer, Flat
79	35539	Clip, Oil fill	211	29212	Screw, Hex hd. Sems, 1/4-28 x 7/16
83	29313C	Valve, Exhaust (Std.) (Incl. No. 86)	216	33344	Baffle, Heat
83	29315C	Valve, Exhaust (1/32" oversize) (Incl. No. 86)	217	28371B	Plate, Fuel tank
84	32644A	Valve, Intake (Std.) (Incl. No. 86)	218	650694A	Screw, Hex flange hd., 5/16-18 x 2
84	32645A	Valve, Intake (1/32" oversize) (Incl. No. 86)			
85	31672	Spring, Valve			
86	31673	Cap, Valve spring			
87	27666	Body, Valve cover			
88	31410	Element, Valve body			
89	*27234A	Gasket, Valve cover			
90	34146	Cover, Breather			

*Indicates Parts Included in Gasket Set, Ref. No. 305.



CRAFTSMAN 4-CYCLE ENGINE

MODEL NUMBER: 143.804072

Ref. No.	Part No.	Part Name	Ref. No.	Part No.	Part Name
219	34182	Bracket, Fuel tank mounting	290B	34144	Decal, Primer
220	650675	Washer, Flat	290C	35282	Decal, Choke
221	650805	Screw, Hex hd. w/belleville washer, 1/4-20 x 11/16	290D	34414	Decal, Warning
228	*33670A	Gasket, Exhaust	290F	35312	Decal, Instruction
229	33697A	Muffler	300	632107A	Carburetor (Incl. No. 96)
230	650327	Screw, Fil. hd. Sems, 1/4-20 x 2-1/2	301	590646	Starter, Rewind
231	8345	Washer, Flat	303		Electric Starter Kit 143.88933 (Optional) Sold as accessory
232	30063	Screw, Hex washer hd. Sems, 1/4-20 x 1/2	305	33683B	Gasket Set (Incl. items marked *)
249	35584	Tank Assy., Fuel (Incl. Nos. 250 & 253)			RPM Settings: Low Speed: 2150, High Speed: 3700.
250	35355	Cap, Fuel tank			*Indicates Parts Included in Gasket Set, Ref. No. 305.
251	650665	Screw, Hex washer hd. self-tap Sems, 1/4-15 x 7/8			In original production the speed control assembly is riveted to the blower housing baffle. Replacement speed control assembly includes screws and nuts for mounting. Replacement baffle has threaded holes.
253	26460	Clamp, Fuel line			
256	30705	Line, Fuel			
270	34694	Cup, Starter			
274	650884	Screw, Hex washer hd., 8-32 x 1/2			
275	650168	Washer, Flat			
276	590574	Handle, Starter			
277	35392	Plug, Starter			
290A	34346	Decal, Instruction			

CARBURETOR NO. 632107A

Ref. No.	Part No.	Part Name
	632107A	Carburetor
1	631615	Shaft & Lever Assy., Throttle
2	631767	Spring, Throttle return
3	631036	Shutter, Throttle
4	650506	Screw, 4-40 x 3/16
5	630766	Spring, Idle regulating screw
6	650417	Screw, Idle regulating
7	632108	Shaft & Lever Assy., Choke
8	630735	Spring, Choke stop
9	631815	Shutter, Choke
10	*630748	Plug, Welch
11	*631027	Plug, Welch
12	*631021	Inlet Needle, Seat & Clip Assy. (Incl. No. 13)
13	631022	Clip, Inlet needle
14	632019	Float, Carburetor
15	*631024	Shaft, Float
16	631951	Bowl, Float (Incl. Nos. 17 & 18)
17	27136A	Drain Assy., Bowl (Incl. No. 18)
18	*27554	Gasket, Bowl drain
21	27110	Gasket, Bowl-to-body
22	*31839	Adjustment Screw Assy., Main (Incl. Nos. 21, 23, 30 & 31)
23	*630740	"O" Ring, Adjustment screw
24	*631838	Screw, Idle adjustment
25	*631028	Gasket, Bowl-to-body
26	631807	Fitting, Fuel inlet
30	630738	Spring, Main adjustment screw
31	630739	Washer, Flat
32	31840	Repair Kit (Incl. items marked *)

NOTES

SEARS

OWNER'S MANUAL

MODEL NO. 536.884811

HOW TO ORDER REPAIR PARTS

CRAFTSMAN®

5 HORSEPOWER 23" DUAL STAGE TRAC-PLUS OPTIONAL ELECTRIC START SNOW THROWER

Each SNOW THROWER has its own MODEL NUMBER found on the motor mount frame.

Each ENGINE has its own MODEL NUMBER found on the BLOWER HOUSING.

Always mention these MODEL NUMBERS when requesting service or Repair Parts for your SNOW THROWER.

All parts listed herein may be ordered through any Sears Service Center/Department and most Sears Stores.

WHEN ORDERING REPAIR PARTS, ALWAYS GIVE THE FOLLOWING INFORMATION:

- * PRODUCT - "SNOW THROWER"
- * MODEL NUMBER - 536.884811
- * ENGINE MODEL NUMBER 143.804072
- * PART NUMBER
- * PART DESCRIPTION

"Your Sears merchandise has added value when you consider that Sears has service units nationwide staffed with Sears trained technicians...Professional technicians specifically trained on Sears Products, having the parts, tools and equipment to insure that we meet our pledge to you...we service what we sell."

SEARS, ROEBUCK AND CO., Chicago IL. 60684

307148 09/16/89

Printed in U.S.A.