



## Parameters

- Input voltage range: DC 6.0-36V
- Output voltage range: DC 0.6-36V
- Output current: 0.000A-5.000A
- Output power: 80W
- Input current limit: Max 7A
- Voltage resolution: 0.01V
- Current resolution: 0.001A
- Voltage precision:  $\pm 0.3\% + 1$  byte
- Current precision:  $\pm 0.4\% + 3$  bytes
- Capacity: 0-999999AH
- Energy: 0-999999WH
- Time: 0-1000Hours

## Protection Function

Hardware protection: output short circuit protection, output anti backflow protection, can directly charge the rechargeable battery, without additional anti backflow diode.

Software protection: over voltage protection (OVP), over current protection (OCP), over power protection (OPP), over temperature protection (OTP), input low voltage protection (LVP), power chip self protection (OEP).

## Note

Full load output power supply requirements: Input power supply between 15V-35V, power > 100W.

The lower the input voltage, the lower the output power.

## Product Structure



## Interface & Button Introduction

Short press the "ON/OFF" button to turn on or off the output. Hold press the "ON/OFF" button for 2 seconds to switch screen display direction, also can realize 360° four-way rotation.

Rotate the potentiometer to turn the page.

## Main Display Interface



- Short press the potentiometer to activate the parameter (voltage / current) to be set.
- Short press the potentiometer to switch between full selection and bit selection.
- If all is selected, the parameter will be displayed in blue background, rotate the potentiometer can switch to set voltage or current.
- If the bit is selected, the corresponding bit will be displayed in blue background, and parameters can be set by rotating the potentiometer.
- Completed setting, hold press the potentiometer for 2 seconds or no operation for more than 6 seconds, the product will automatically exit the setting and save parameters.

## Capacity Recording Interface

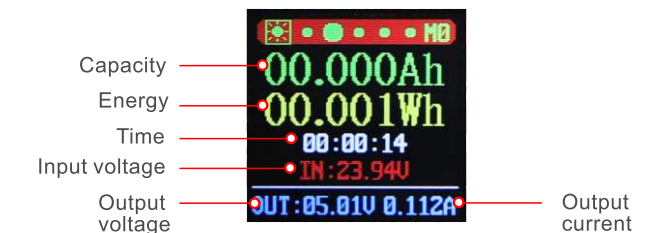

- Short press the potentiometer to select all "capacity / energy / time". If selecting all, the corresponding ones will be displayed in blue background.
- Rotate the potentiometer to switch the parameter to be cleared. Short press the potentiometer to clear the selected parameter.
- After selecting, hold press the potentiometer for 2 seconds or no operation for more than 6 seconds, the product will automatically exit the setting.

## Voltage Current Curve Interface

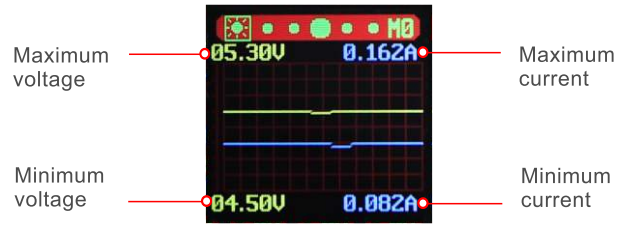

Each grid represents 0.1V / 0.01A

Note: the potentiometer is disable at this interface

## Protection Setting Interface

Default turns output ON/OFF when power on

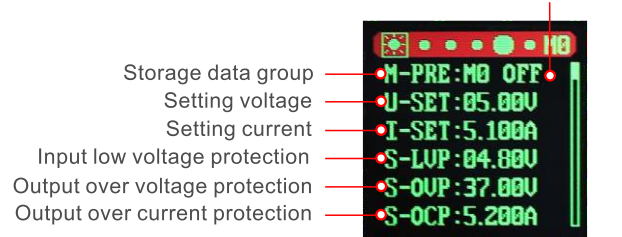

Scroll bar indication

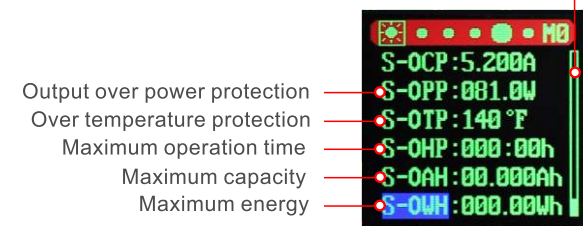

- Short press the potentiometer to activate the parameter to be set.

- Short press the potentiometer to switch between the parameter name and bit selection.

- If selected the parameter name, it will be displayed in blue background, rotating the potentiometer can switch the parameter to be set.

- If bit selected, the corresponding bit will be displayed in blue background and rotating the potentiometer can set the parameter.

- Completed setting, hold press the potentiometer for 2 seconds or no operation for more than 6 seconds, the product will automatically exit the setting and save parameters.

## Data group function description:

10 data groups of M0-M9 can be stored. Default will be stored in data group M0. Hold press the potentiometer for 2 seconds on any interface can quickly call up the M1/M2 data group, and the serial number of the data group will be displayed at the interface index.

In the protection setting interface, selected the data group, then rotate the potentiometer to call up the corresponding data group.

After the parameters in the data group are modified and exited, the corresponding parameters will be stored in the current data group by default.

Note: the output will be off by default after data group switched.

Set voltage U-SET: 0.6-36V

Set current I-SET: 0-5.1A

Input LVP default 4.8V, adjustable

Output OVP default 37V, adjustable

Output OCP default 5.2A, adjustable

Output OPP default 81W, adjustable

OHP: when the parameter is not set to 0, OHP will be turned on. Once reaches the set time, the power will automatically turn off the output.

OAH: when the parameter is not 0, OAH will be turned on. Once the capacity reaches the set parameter, the power will automatically turn off the output.

OWH: when the parameter is not 0, OWH will be turned on. Once the energy reaches the set parameter, the power will automatically turn off the output.

## System Parameter Setting Interface

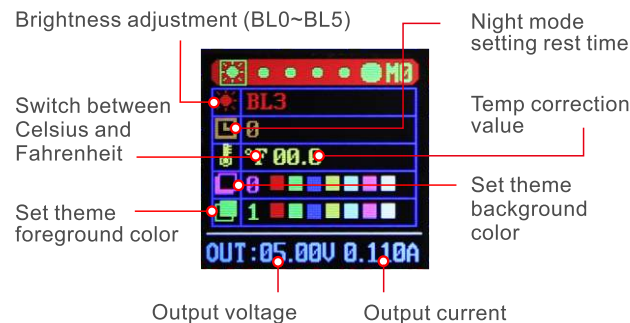

- Short press the potentiometer to select or switch the parameter to be set. If selected, the parameter will be displayed in blue background, rotating the potentiometer can set the parameter.

- Completed setting, hold press the potentiometer for 2 seconds or no operation for more than 6 seconds, the product will automatically exit the setting and save parameters.

## Application

- Has constant current function, can be used to charge the rechargeable battery within 0.6V~36V.

(1) confirm the floating charge voltage and charging current of your rechargeable battery. (if the parameter of lithium battery is 3.7V/2200mAh, the floating charge voltage is 4.2V; if it is 12V rechargeable battery, generally set the floating charge voltage to about 14V)

(2) under no-load condition, set the output voltage to floating charge voltage. (if 3.7V lithium battery is charged, adjust the output voltage to 4.2V)

(3) set the charging current. (constant current value)

(4) connect the battery for charging.

Note: when charging the battery, the positive and negative poles of the battery should not be connected reversely, which is easy to burn the product!

- Has constant current function, can be used to drive LED directly.

(1) confirm the working current and maximum working voltage of the LED is going to drive.

(2) under no-load condition, set the voltage value and current value to make the output voltage reach the maximum working voltage and current of LED.

(3) connect LED and test.

Recommend product on Amazon:



DC Buck Module

Visit DROK Store on Amazon:

