



Masport®



Barbecues

Masport Pacific, Maestro & Lifestyle Plus

OWNER'S MANUAL

Please read these instructions carefully before assembly, to reduce risk of fire, burn hazard or other injury.

Keep these instructions in a safe place for future use.

This manual covers a range of barbecues which include:
Pacific, Maestro & Lifestyle Plus

Do not install in, or connect to the consumer piping or gas supply system of a boat or caravan.

This BBQ is designed for outdoor use only.

www.masport.com

Part N°:546992.A.0

CONTENTS

SAFETY AND WARRANTY INFORMATION	2
PARTS DIAGRAM, PARTS LIST & FIXTURES	4
ASSEMBLY INSTRUCTIONS	7
LEAK TESTING	19
INSTALLATION	20
OPERATION	21
TROUBLESHOOTING	24
CARE AND MAINTENANCE	25
TECHNICAL DATA	28

SAFETY AND WARRANTY INFORMATION

KEEP THE INSTRUCTIONS IN A SAFE PLACE FOR FUTURE USE.



DO NOT OPERATE THIS BBQ BEFORE IT HAS BEEN ASSEMBLED CORRECTLY AND YOU HAVE READ AND UNDERSTOOD THESE INSTRUCTIONS.



These instructions are intended as a general guide and do not supersede national or local codes in any way. Contact local authorities for clarity of laws relating to the operation of this appliance.

Do not install in, or connect to the consumer piping or gas supply system of a boat or caravan

SYMBOLS IN THIS OWNER'S MANUAL



Possible hazard or hazardous situation. Not observing this instruction can lead to injuries or cause damage to property.



Important information on proper handling. Not observing this instruction can lead to faults in the BBQ.



User information. This information helps you to use all the functions correctly.

Failure to follow these instructions could result in fire or explosion which could cause property damage, personal injury or death.

Accessible parts may be very hot. Keep young children away from the hot appliance at all times (even while cooling down). Some parts of this grill may have sharp edges especially as

mentioned in this manual! Wear suitable protective gloves if necessary.

Assembled parts sealed by the manufacturer must not be altered by the user. Any modification of the appliance by unauthorised persons may be dangerous.

IMPORTANT SAFETY INFORMATION

Please read and understand this manual fully before assembly and use.

- The Manufacturer's Warranty may be voided by the incorrect use of this product.
- The Manufacturer or their Agents can accept no liability for the unsuitability of, or any damage to, food that is cooked on this appliance.
- Use the correctly specified fuel with this barbecue. Check with your dealer for the specific fuel for which this barbecue has been designed.

OWNER'S MANUAL

- The operator must understand all the safety requirements detailed in this manual before using the barbecue.
- If you have any queries regarding these instructions, contact your local dealer for clarification before you use your barbecue.
- The unit must be correctly assembled before use. Failure to follow the manual's instructions could result in serious damage or injury.

PERSONAL SAFETY

- The use of alcohol, prescription or non-prescription drugs may impair the consumer's ability to properly assemble or safely operate this barbecue.
- The barbecue should be carefully checked for operational use every time before use.
- Never try to move the barbecue when it is on, or before it has had time to cool down.
- The person operating this barbecue should pay constant attention

to the food being cooked.

- Do not leave the barbecue unattended when it is alight. The person should remain at the barbecue at all times when it is alight/cooking.

THIRD PARTY SAFETY

- The operator is responsible for the safety of all third parties while the barbecue is in use.
- Onlookers should be kept a safe distance away from the barbecue when it is in use.
- Keep children and animals well away while the barbecue is in use and while it is cooling down.

LOCATION

- Do not use indoors. Barbecue units are designed for OUTDOOR USE ONLY.
- Use in a weather-protected area, preferably under shelter.
- Ensure that the barbecue is on an even and secure surface before operating. Use the castor locks if fitted to lock the wheels in place.
- Do not use within one metre of any flammable surface of structure.

BURN AWARENESS

- Parts of the barbecue do get extremely hot and could cause serious burns – touch test the surface before applying a firm grip.
- The hood handle can become hot! The use of cooking gloves and long sleeves are advised.
- If cooking with the hood closed, be very careful opening the hood, a sudden rush of hot air could burn an unprotected arm.

GAS AWARENESS

- Ensure all gas couplings and hoses are in good condition and have been correctly fitted.
- Leak test all gas lines and connections before use.
- Do not store flammable materials near this barbecue.
- Do not place the gas bottle underneath the barbecue directly.
- Do not store spare LPG cylinders under or near this barbecue.
- Do not place or use aerosols near this barbecue.
- Do not store or use gasoline or other flammable vapours or liquids in the vicinity of this barbecue.
- Ensure that the gas is turned OFF at the cylinder after use and while the barbecue is unattended.
- When turning off the barbecue, shut off the gas at the supply source before turning off all the burner controls.
- Do not store gas cylinders below ground level. ULPG is heavier than air. Should a leak occur, the gas will collect and could ignite due to presence of a flame or electric spark.

ELECTRICAL AWARENESS

-  Symbol IEC 60417 -5172 (2003-2) Class II equipment.
- This appliance is not intended for use by persons (including children) with reduced physical, sensory or mental capabilities, or lack of experience and knowledge, unless they have been given supervision or instruction concerning use of the appliance by a person responsible for their safety.
- Children should be supervised to ensure they do not play with the appliance.
- If the supply cord is damaged, it must be replaced by the manufacturer, its service agent or similarly qualified persons in order to avoid a hazard.
- BBQs with Grill Lights & USB parts run on AC power. It is IMPORTANT to ensure the care is taken to the location of the BBQ. See section in this manual which refers to "Location".
- Turn power OFF when not in use.
- Avoid using in wet conditions.

- If an external lead is being used, ensure that it is correctly rated and meets current safety certification requirements.
- Ensure the power is turned OFF before connecting and disconnecting any components on the BBQ.
- Ensure power leads are kept away from any hot parts of the BBQ.
- Do not place the power lead where hot oil or fat can drip onto the lead.

FOR YOUR SAFETY AND OTHERS

If you smell gas:

- Shut off the gas supply to the barbecue.
- Extinguish any open flame (candles, cigarettes, etc.)
- Clear the area to allow the unburned gas to dissipate.

Be aware of the reason for the gas smell, address this before continuing. Should the gas odour come from the LPG cylinder, immediately contact the fire department from an elevated safe distance.

Connecting the gas cylinder to the barbecue, refer to that section in the manual.

Leak testing, refer to that section in the manual.

SAFETY EQUIPMENT

When cooking with oil/grease, fire extinguishing materials should be readily accessible.

In the event of an oil/grease fire do not attempt to extinguish with water or alcohol. Use type BC dry chemical fire extinguisher or smother the fire with dirt, sand or baking soda.

RAIN HAZARD

In the event of rain while cooking with oil/grease, turn off the gas supply and all burners, cover the barbecue as soon as possible. Move people/animals away from around the barbecue. Do not attempt to move the barbecue until it has cooled and can safely be moved.

INSTALLATION

This Cooking Appliance is For Outdoor Use Only and shall not be used in a building, garage or any other enclosed area.



NOTE!

Read carefully the pages containing the parts and assembly before assembling your gas grill.

THE LOCATION FOR YOUR GRILL

Do not use your gas grill in garages, porches, breezeways, sheds or other enclosed areas. Your gas grill is to be used outdoor only, at least 700mm from the back and side to any combustible surface. The grill should not be placed under any surface that will burn. Do not obstruct the flow of combustion and ventilation air around the grill housing. Keep this barbecue away from any flammable materials!

GAS AND REGULATOR INFORMATION

Gas grills are used safely by millions of people when following simple safety precautions. This barbecue is designed for ULPG use only. Bottle size of 4.5kg or greater is recommended for use with this barbecue. The regulator must have an outlet pressure of 2.75kPa. You must have the correct regulator and bottle for the barbecue to operate safely and efficiently. The items used in the fuel system are designed for operation with the grill.

(See parts list for replacement items).

WARRANTY

Refer to the warranty supplied with this BBQ. Should any part fail due to defective workmanship or faulty materials within the specified period from the date of purchase, Masport will replace or repair the defective part free of charge. Refer to the warranty for details. Do not use a BBQ that is unsafe.

LPG CYLINDER

The cylinder manufacturer/distributor is responsible for the safety and performance of the LPG cylinder. This is not included in the Masport BBQ warranty. Do not use a cylinder that is unsafe.

DISPOSAL OF PACKAGING

Remove all protective packaging including any protective film from stainless steel surfaces.

Make sure you properly dispose of, or recycle the packaging material where possible to comply with applicable waste disposal laws in your area.



NOTE!

The images/instructions in the next few pages cover many models of BBQ, please ignore instructions for features that are not included with your BBQ.

PARTS DIAGRAM, PARTS LIST & FIXTURES

4 BURNER (WITH REARBURNER) PARTS DIAGRAM

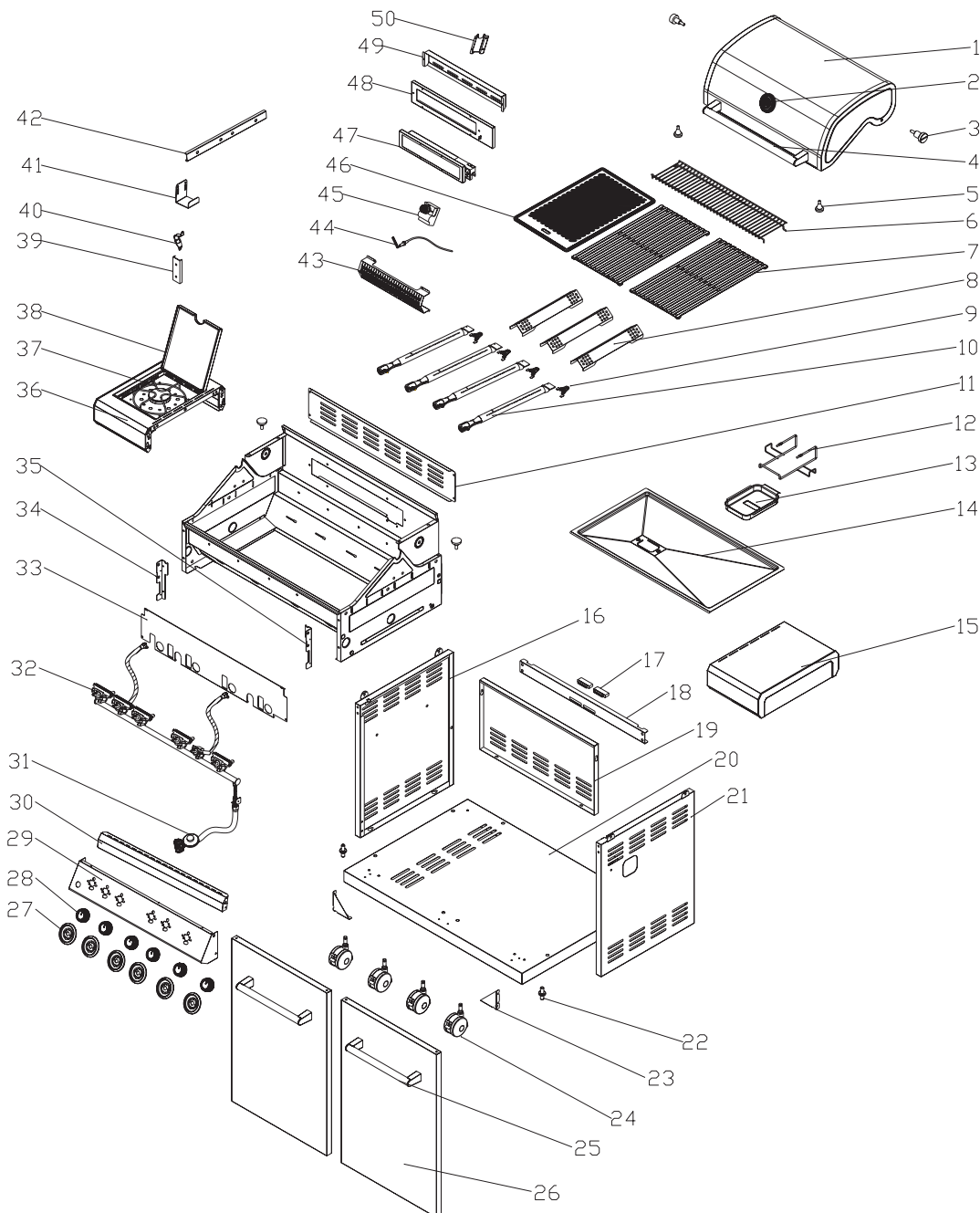
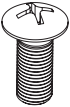
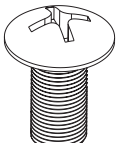
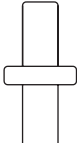
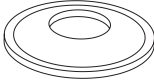

*IMAGE IS FOR ILLUSTRATION PURPOSE ONLY AND MAY SHOW COMPONENTS THAT ARE NOT INCLUDED ON ALL MODELS OF BBQ.

4 BURNER WITH REARBURNER PARTS LIST

NO.	Parts Name	QTY	NO.	Parts Name	QTY
1	Lid assembly	1	26	Door	2
2	Thermometer	1	27	Knob base ring	6
3	Lid Spindle	2	28	Knob	6
4	Lid Handle	1	29	Control Panel	1
5	Bumper	4	30	Top of control panel	1
6	Warm Rack	1	31	Regulator	1
7	Cooking Grill	2	32	Gas hose with valves	1
8	Flame Tamer	3	33	Inner of control panel	1
9	Clip	4	34	Connect Panel 1	1
10	Main burner	4	35	Connect Panel 2	1
11	Rear panel of Firebox	1	36	Side Burner	1
12	Grease box Rack	1	37	Side Burner Rack	1
13	Grease Box	1	38	Lid of side burner	1
14	Grease Tray	1	39	Bottle opener panel	1
15	Side Table	1	40	Bottle Opener	1
16	Left panel of cart	1	41	Gas Cylinder Hook	1
17	Door Magnet	2	42	Gas Cylinder Hook Panel	1
18	Front support Beam	1	43	Rear burner cover	1
19	Rear panel of Cart	1	44	Rear burner ignition wire	1
20	Bottom panel of cart	1	45	Rear burner ignition	1
21	Right panel of Cart	1	46	Cast Iron Plate	1
22	Door spindle	2	47	Rear Burner	1
23	Triangle panel of Cart	2	48	Rear burner panel	1
24	Castors	4	49	Rear burner cover	1
25	Door Handle	2	50	Rear burner hose cover	1

FASTENERS

A	B	C	D
 x11 5/32"-32	 x14 x12 for Lifestyle Plus 1/4"-20	 x2	 x4



CAUTION:

Although we take every effort to ensure that the assembly process is as easy as possible, it is inherent with fabricated steel parts that corners and edged can cause cuts if improperly handled during assembly procedures. Be careful while handling any parts during assembly. It is strongly recommended that you protect hands with a pair of work gloves.

ASSEMBLY INSTRUCTIONS

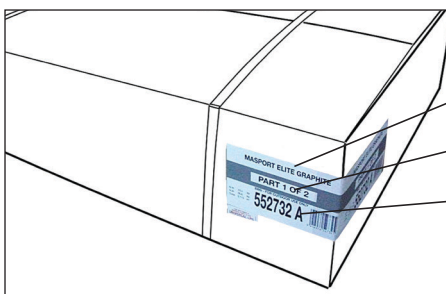

Product Description

Carton Identification

Product Part Number

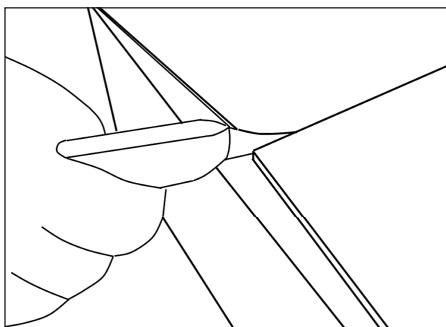
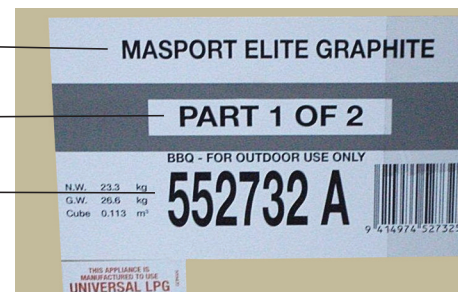

Open the carton by removing the shipping straps then slitting along both ends. Cut the tape only by a small amount in the middle, finish by lifting the carton flaps with your hand.

Unpack the entire carton, this carton will be used as a surface protector as the cabinet is being built. Open the carton as shown and place where the BBQ will be assembled

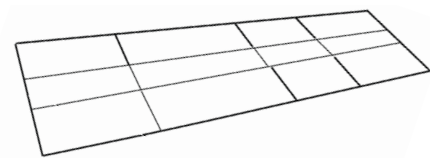
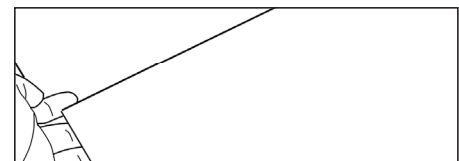

Tools needed for assembly: Crosshead screwdriver, 10mm A/F Spanner.



NOTE:

When assembling the barbecue, ensure it is sitting on a flat surface.

For illustration purposes a 4 Burner with Rear Burner is used in assembly steps shown in the next few pages. This cabinet assembly is easier to assemble with two people.

Before attempting to assemble the BBQ, lay out all of the components and identify each of them, this will make it easier to assemble the BBQ.



STEP 1

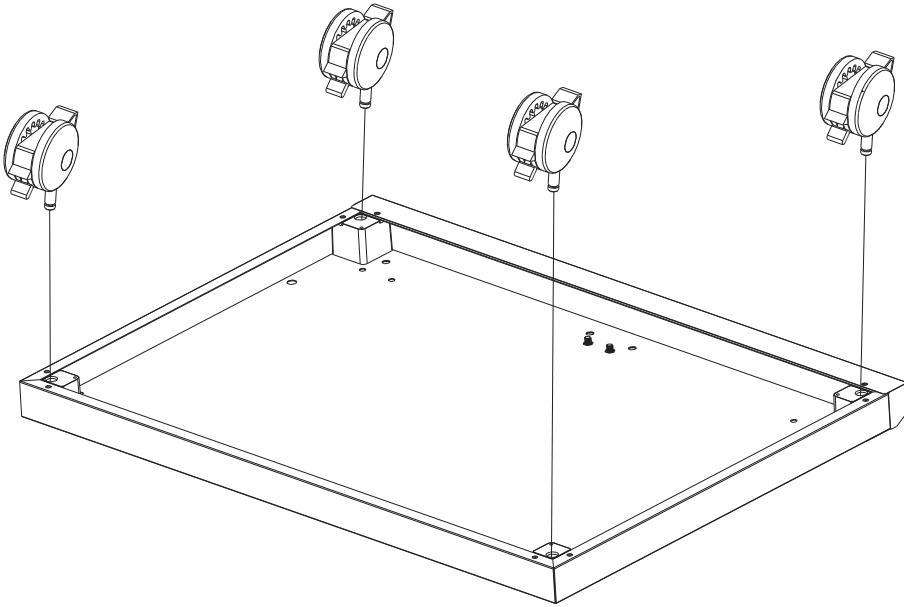

STEP 2

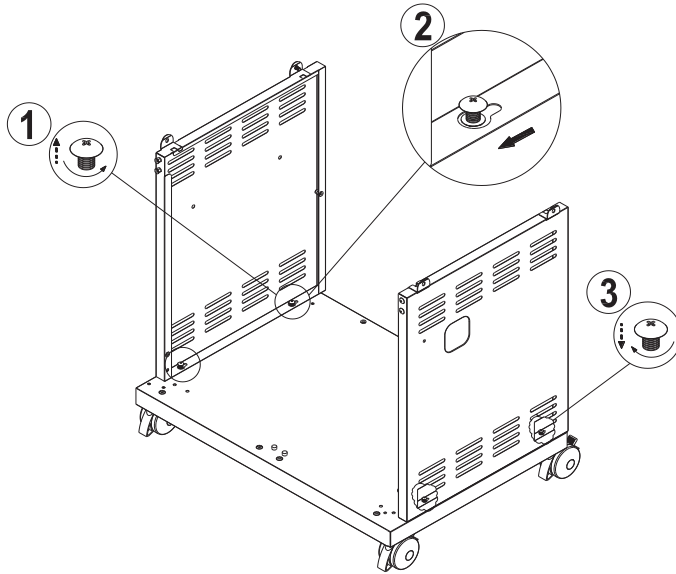

STEP 3

For Pacific / Masetro

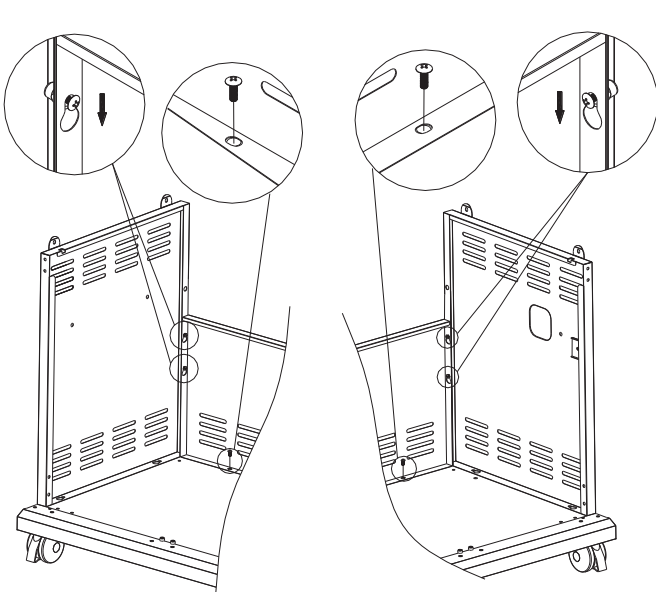

4 x B



For Lifestyle Plus

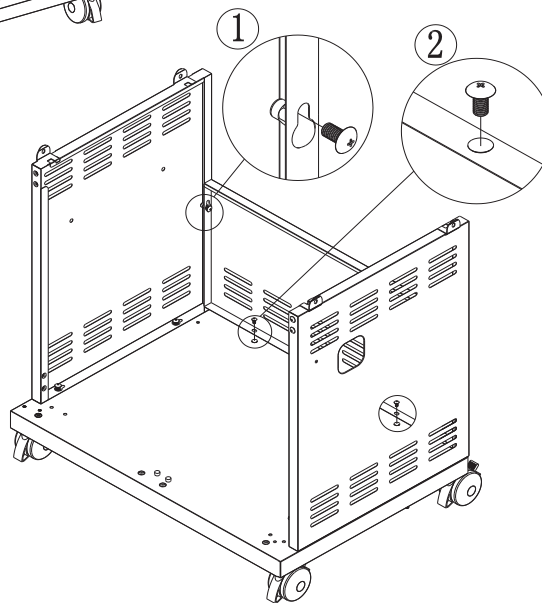



STEP 4

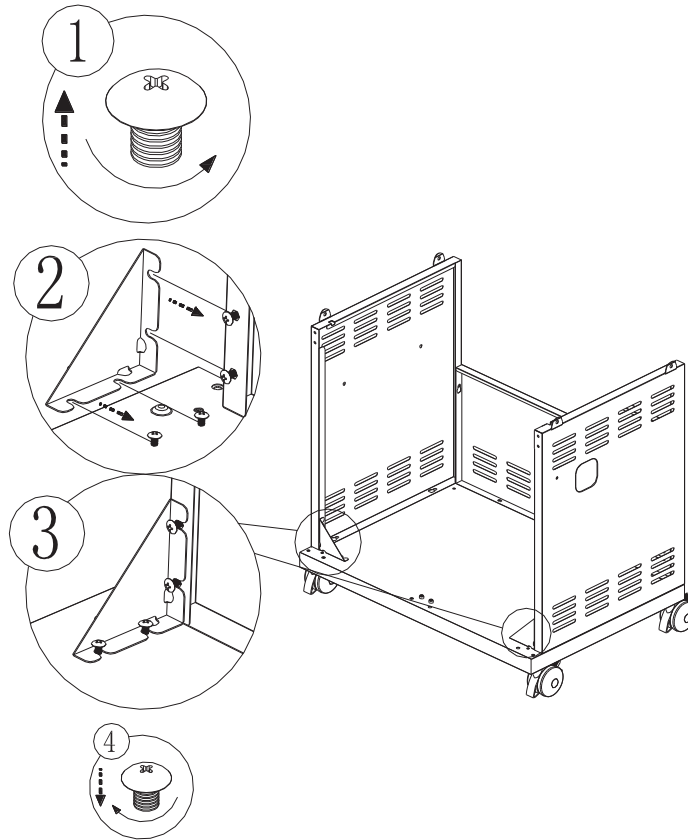

STEP 5

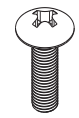
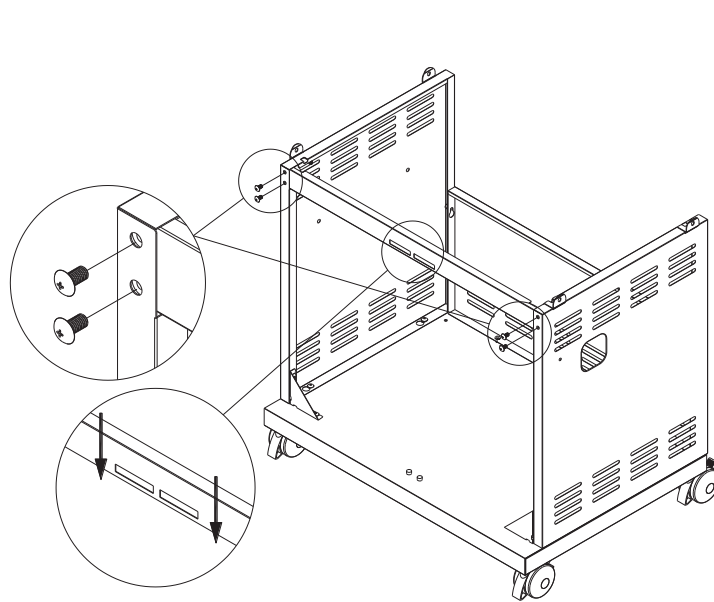

4 x A

STEP 6

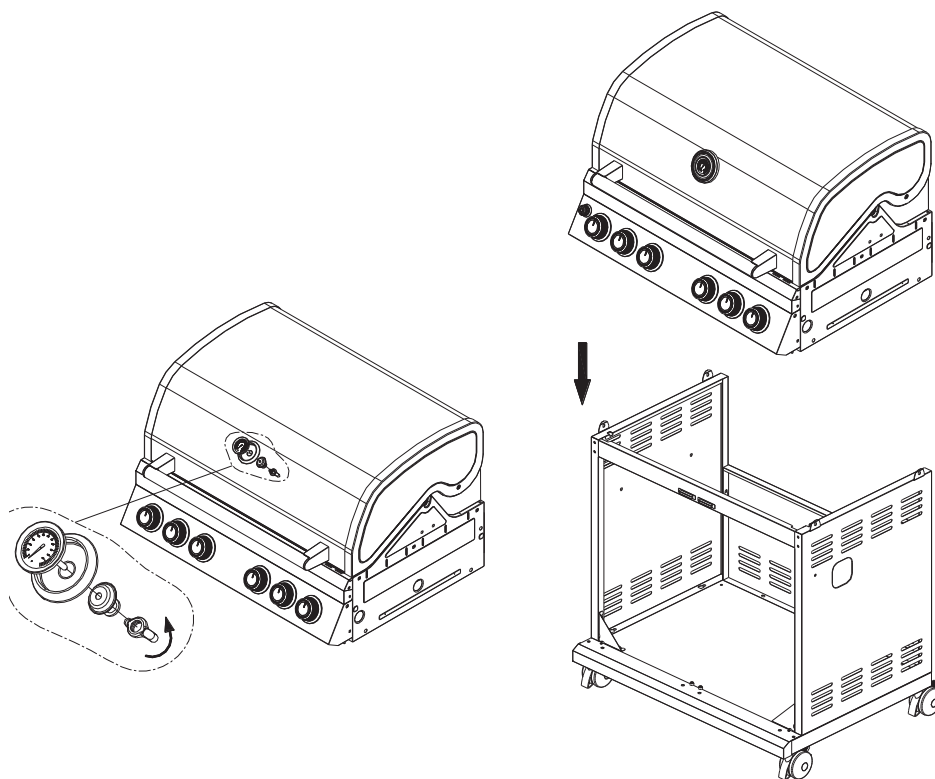

STEP 7

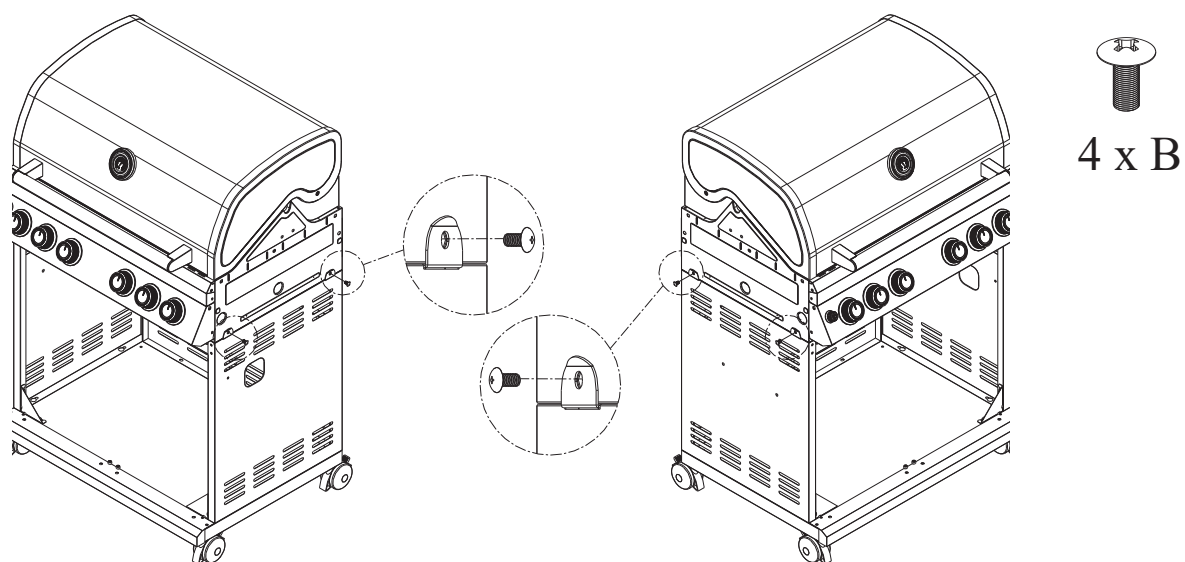

STEP 8

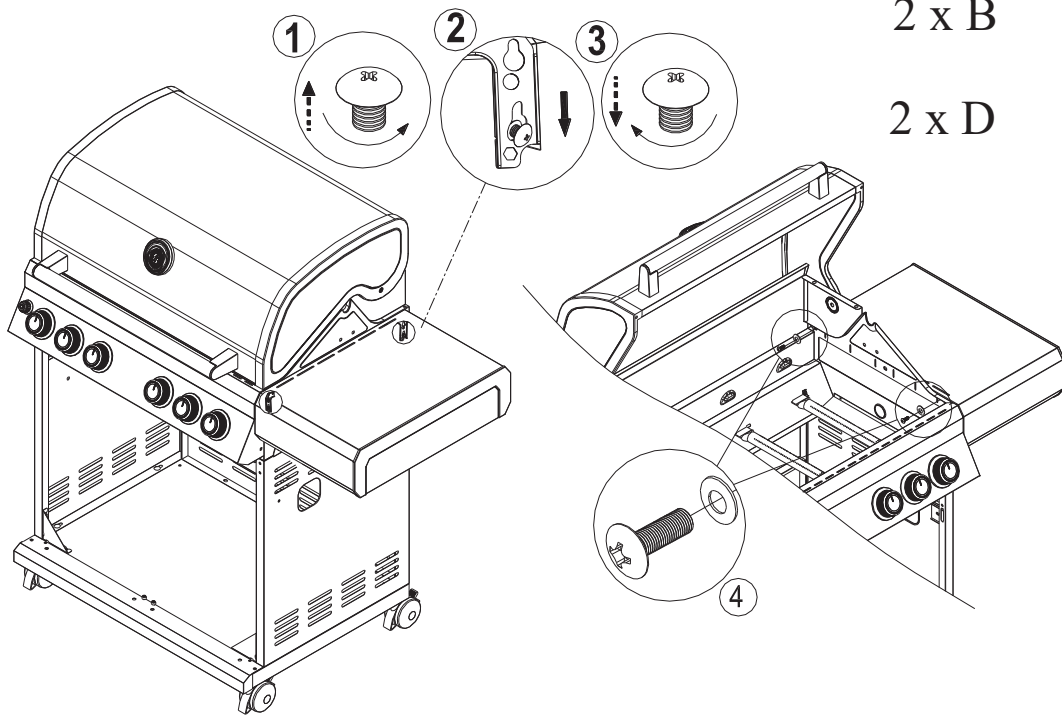

STEP 9

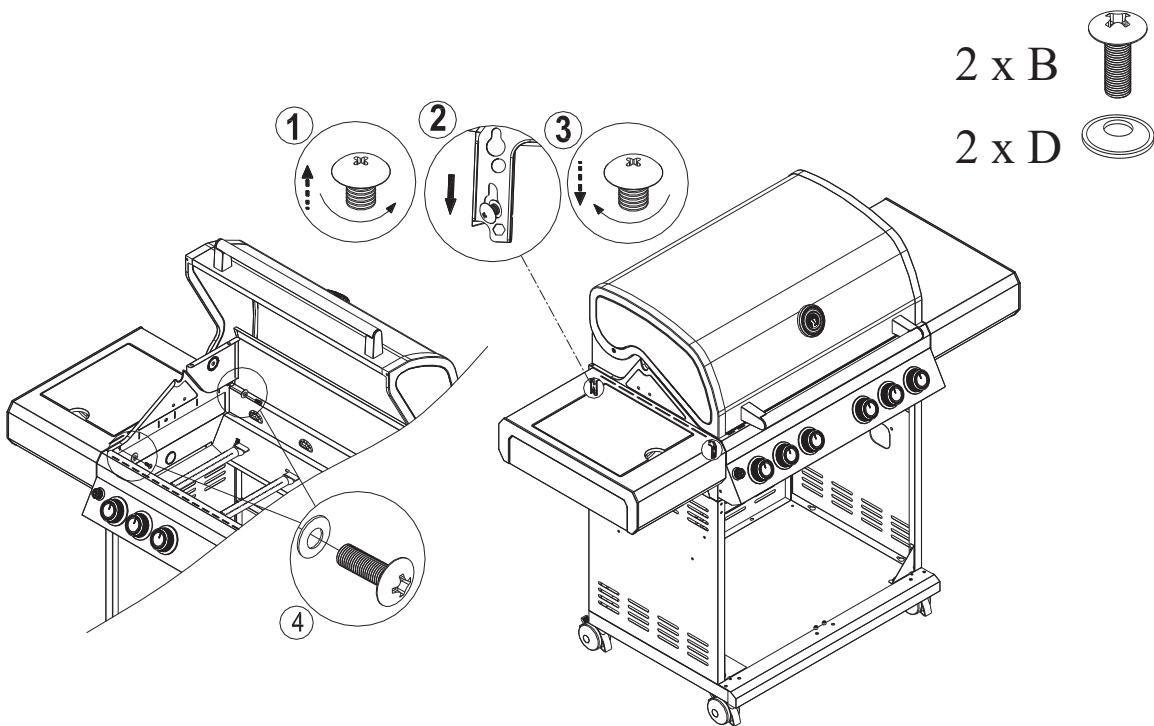

STEP10

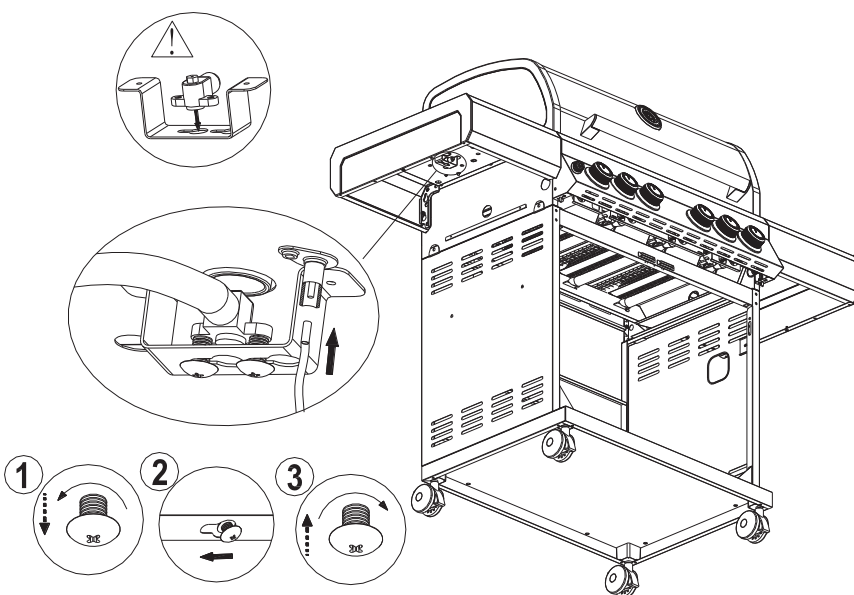

STEP11

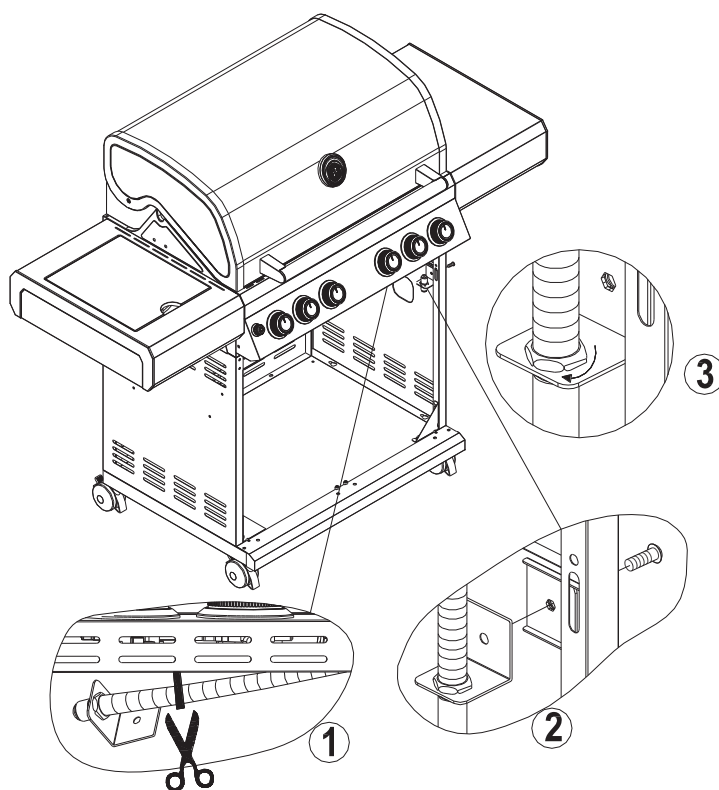

1 x A 



STEP 12

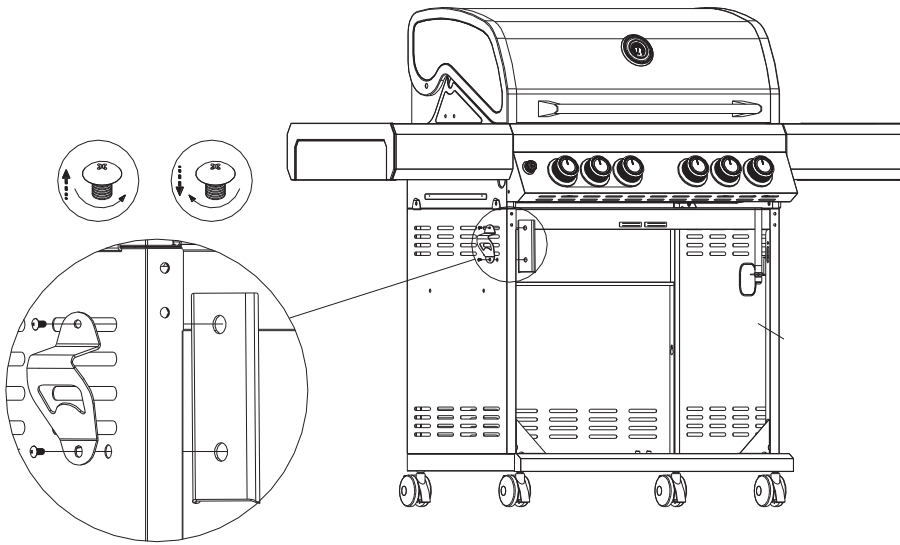

STEP 13

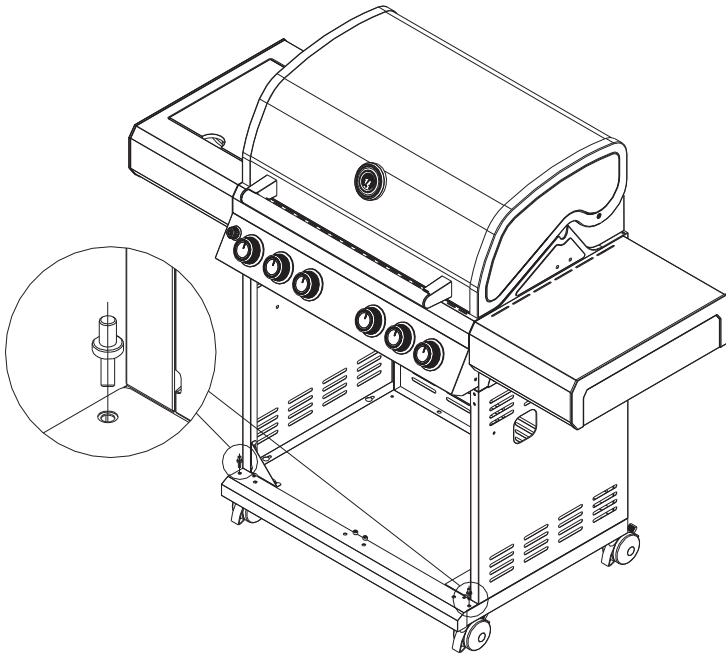

2 x C 

STEP 14

For Pacific / Masetro

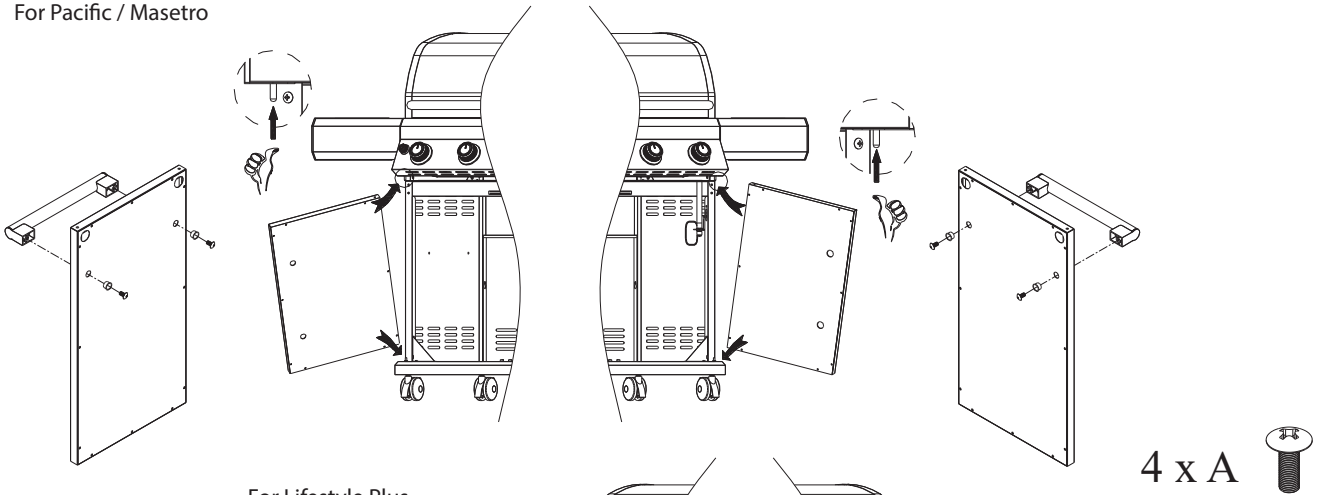

For Lifestyle Plus

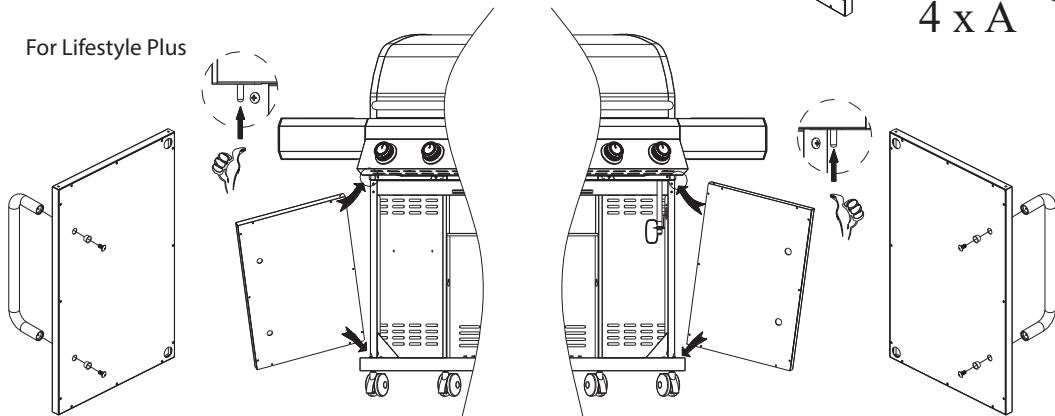

STEP 15

2 x A

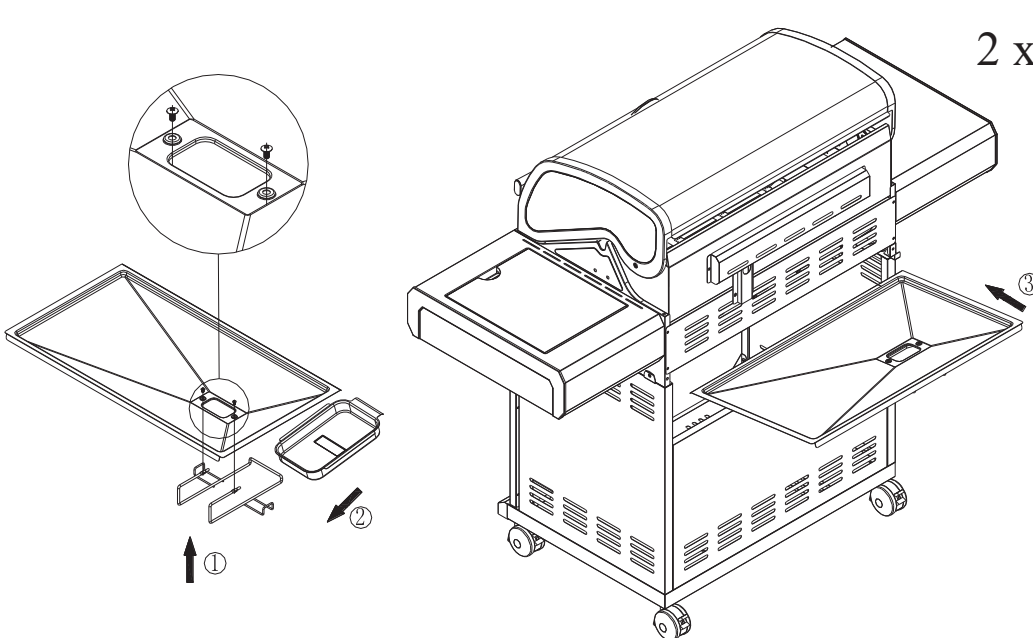

STEP 16

For Pacific / Masetro Series ONLY

4 x A 

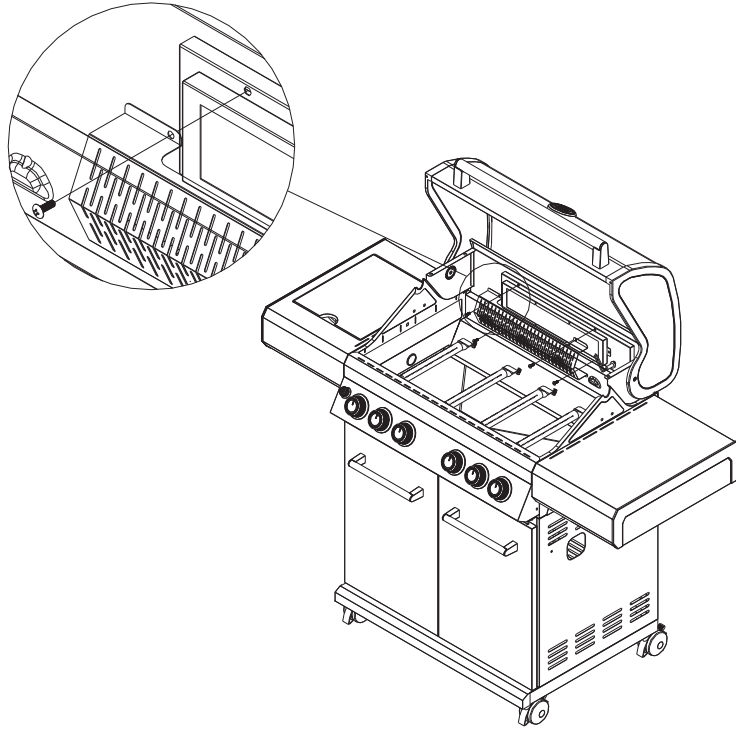

STEP 17

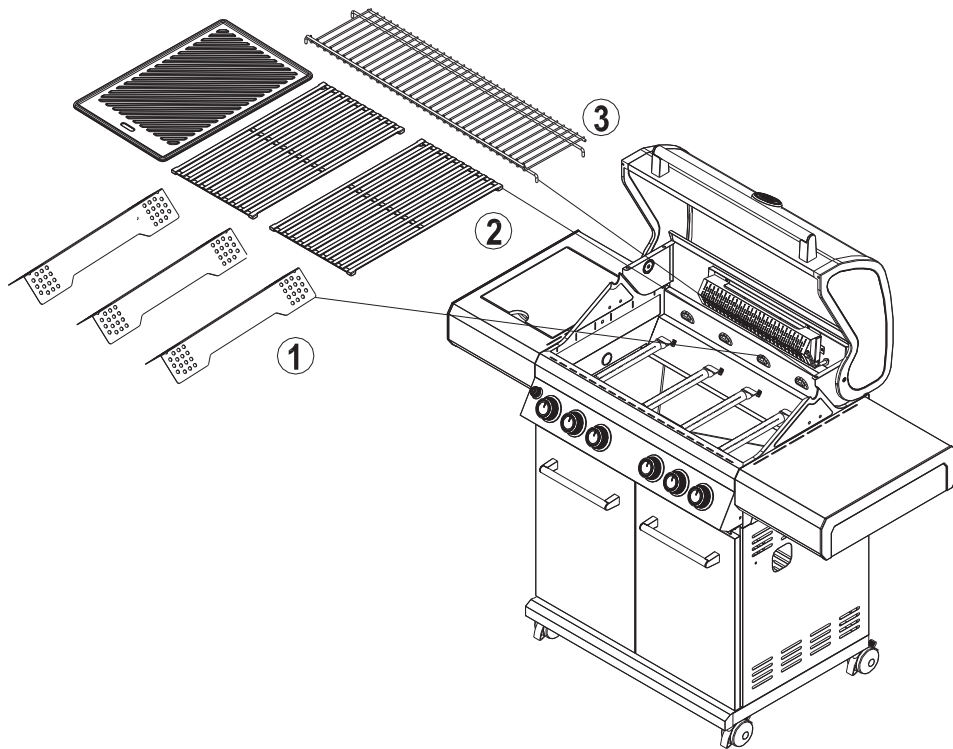



STEP 18

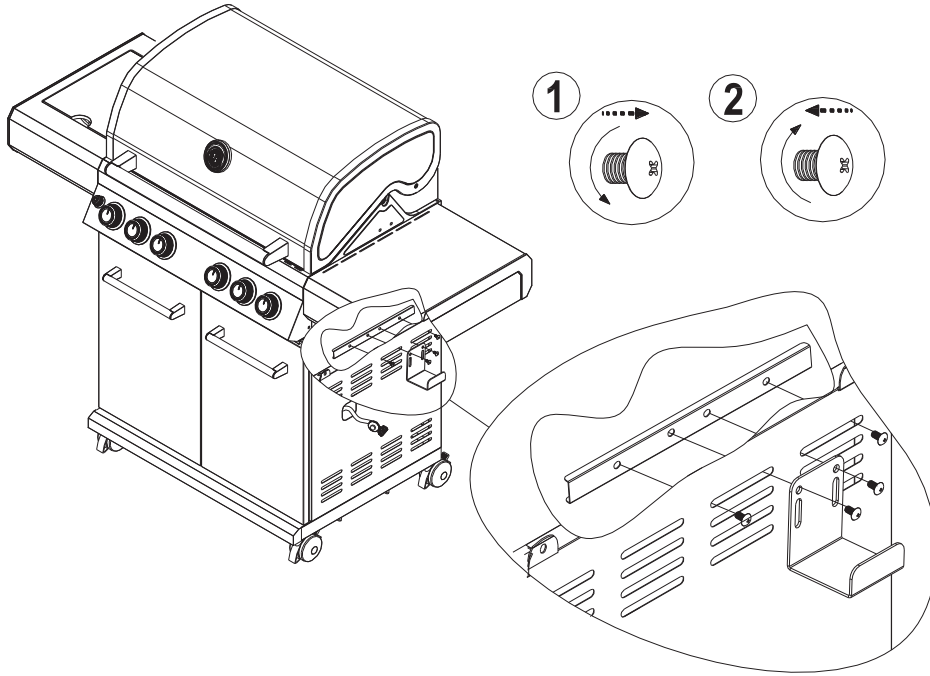

STEP 19

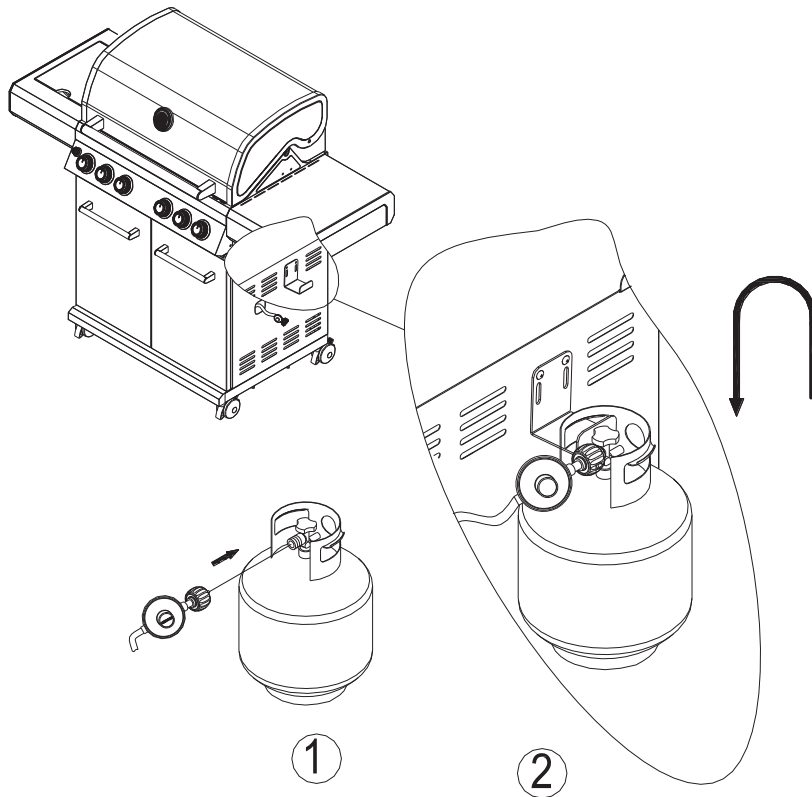

ROTISSERIE (OPTIONAL)

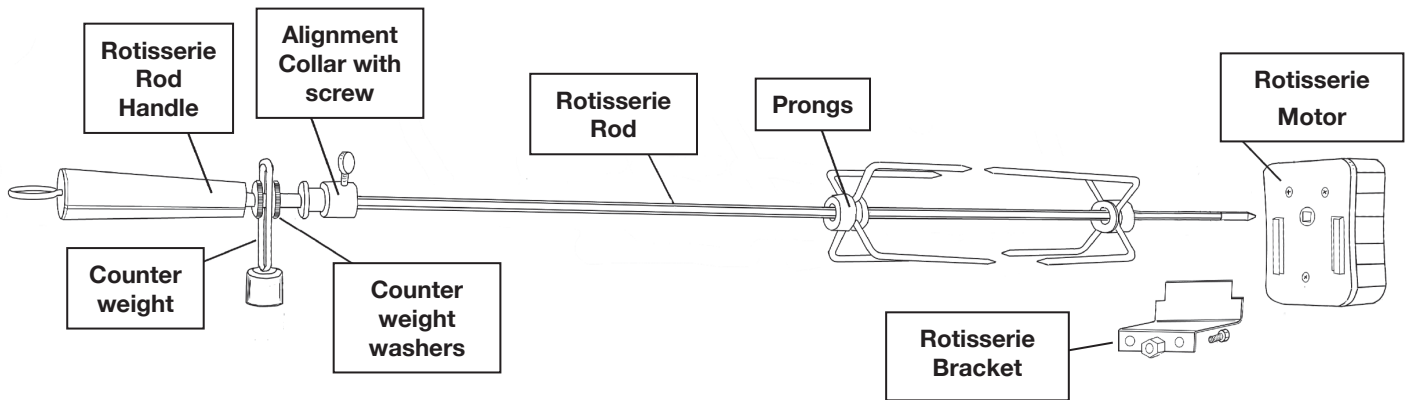

Assembling the Rotisserie Rod with Prongs

Slide the prongs into the rotisserie rod. Slide in the alignment collar with screw on the threaded end, use the round nut, counter weight, nut and then rotisserie handle in this order.



Attaching the Rotisserie Bracket onto the BBQ grill:

Open the BBQ hood. Use two screws provided with the rotisserie bracket in the mounting holes provided in the side panel of the grill body.



Slide the Rotisserie motor on to the bracket and place the rotisserie rod assembly locating in the square bush in the motor as above.



While using the rotisserie, adjust the counter weight to your requirement.

LEAK TESTING

When to Test: The BBQ gas bottle, regulator & hose assembly should be checked for leaks, using the soapy water leak test, every time you reconnect your regulator to the BBQ gas bottle. You should also test after any long period of non-use, such as at the beginning of BBQ season.

What to use: You will need a soapy water solution to check for any leaks. Mixing liquid hand soap with water will work fine (do not use any other household cleaning products).



How to Test: Put some soapy water in a spray bottle or a dish. Turn on the gas bottle but do **not** turn on the BBQ. Next, spray the entire valve, regulator and hose assembly with the soapy water including where the hose connects to the BBQ. Alternatively, you can apply the soapy water with a paint brush, basting brush.

Bubbles will form if there is a gas leak and you may also smell the gas. If you find a leak, turn off the gas bottle immediately!

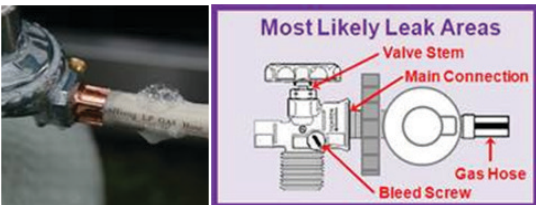

Do not turn back on or attempt to use the BBQ if a gas leak has been detected, contact your local BBQ Dealer for repair.

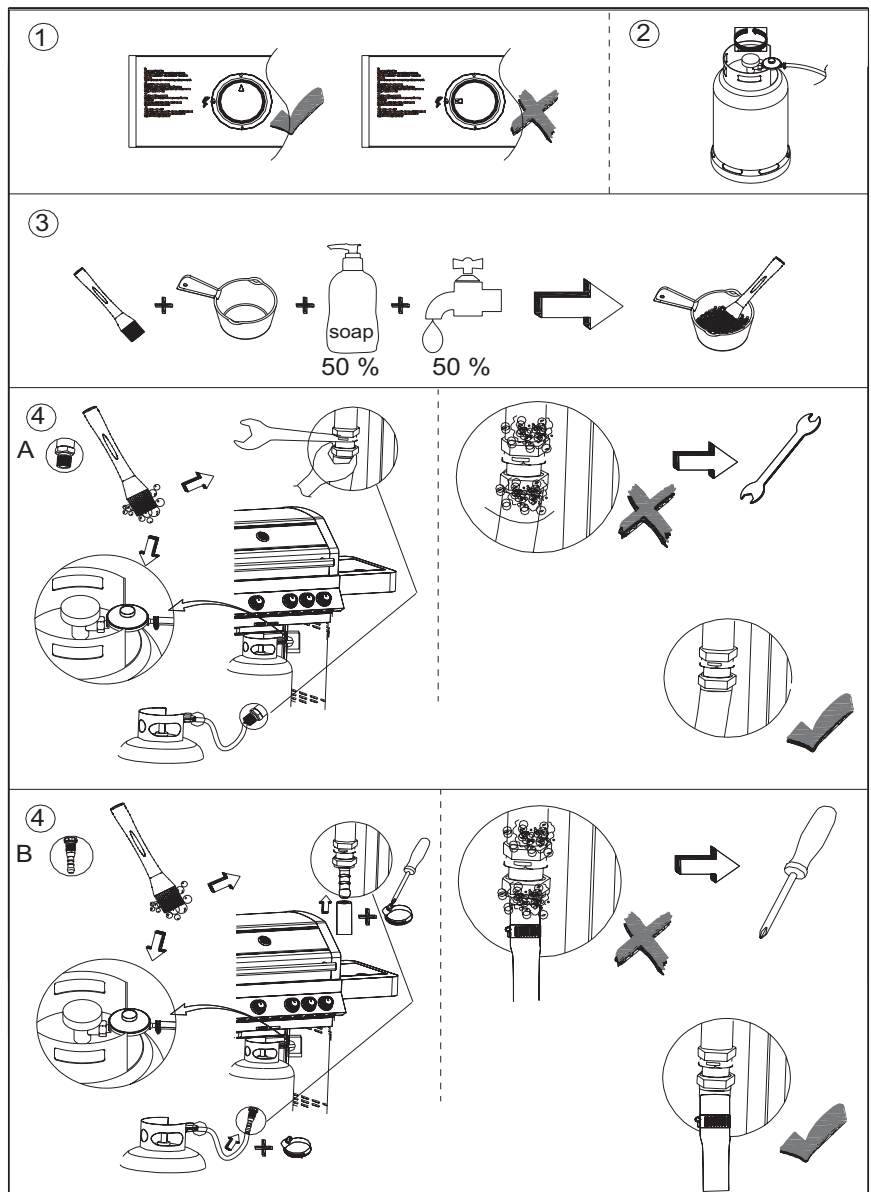

INSTALLATION

This barbecue is for outdoor use only and should be placed in a well-ventilated area. Take care to ensure that the minimum clearances guidelines are followed.

MINIMUM CLEARANCES:

- From sides: 700mm; From back: 700mm
- From above (vertical): 1500mm

Keep this barbecue away from any flammable materials! This appliance shall only be used in an above ground open-air situation with natural ventilation, without stagnant areas, where gas leakage and products of combustion are rapidly dispersed by wind and natural convection. This barbecue is not designed for marine use.

ANY ENCLOSURE IN WHICH THE APPLIANCE IS USED SHALL COMPLY WITH ONE OF THE FOLLOWING:

1. An enclosure with walls on all sides, but at least one permanent opening at ground level and no overhead cover.
2. Within a partial enclosure that includes an overhead cover and no more than two walls.
3. Within a partial enclosure that includes an overhead cover and more than two walls, the following shall apply:
 - a) at least 25% of the total wall area is completely open and unrestricted
 - b) at least 30% of the remaining wall area is open and unrestricted

In the case of balconies, at least 20% of the total of the side, back and front wall areas shall be and remain open and unrestricted.

See following diagrams for further illustration:

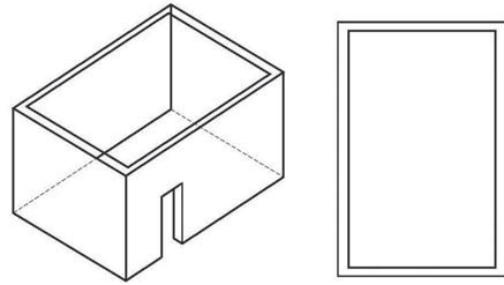

FIGURE F1-OUTDOOR AREA-EXAMPLE 1

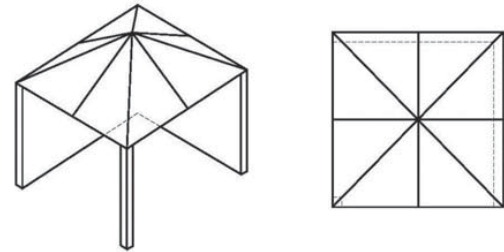

FIGURE F2-OUTDOOR AREA-EXAMPLE 2

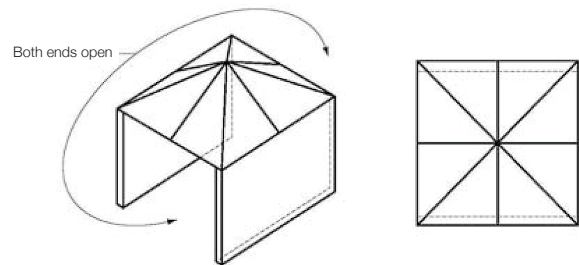

FIGURE F3-OUTDOOR AREA-EXAMPLE 3

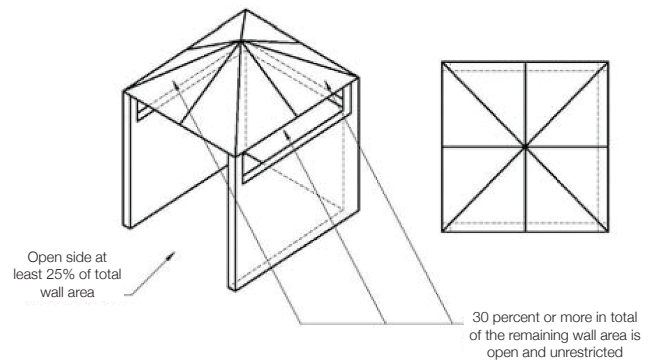

FIGURE F4-OUTDOOR AREA-EXAMPLE 4

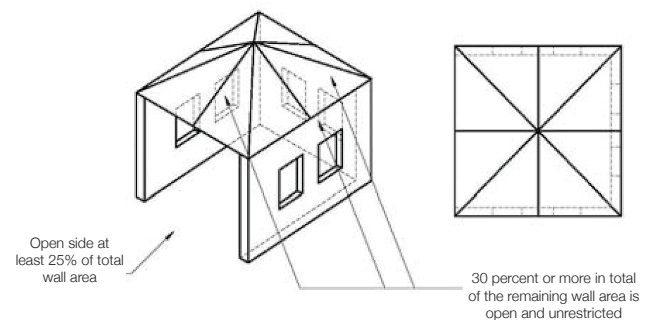

FIGURE F5-OUTDOOR AREA-EXAMPLE 5

OTHER PRECAUTIONS

Do not obstruct any of the ventilation openings in the barbecue body. Also, position the gas supply cylinder inside the cabinet, in the cylinder base positioning hole. Should you need to change the gas cylinder, confirm that the cylinder is off, and that there are no sources of ignition (cigarettes, open flame, sparks, etc.) near before proceeding. Be sure to inspect the gas hose and ensure it is free of any twisting or tension. The hose should hang freely with no bends, folds, or kinks, which could obstruct free flow of gas. Apart from the connection point, no part of the hose should touch any hot barbecue parts. Inspect the hose before use. If the hose is damaged, it must be replaced with a hose suitable for use with ULPG and meet the national standards for the country of use. The length shall not exceed 1.5m. Should minimum clearances not be adhered to severe flare up may be experienced due to lack of airflow around the barbecue, thus voiding manufacturer's warranty.

GAS AND REGULATOR INFORMATION

This barbecue is designed for LP gas use only. Bottle sizes of 4.5kg or greater are recommended for use with this barbecue. Suitable LPG regulators must have an outlet pressure of 2.75 kPa. You must have the proper regulator and bottle in order for the barbecue to operate safely and efficiently. Please consult your local gas dealer for the most suitable gas cylinders. Please note the regulator supplied with this barbecue is of an approved type.

The manifold thread type is 5/8" x 18.

For more information on pipe sizing, please refer to AS/NZS 5601 / AG601.

The gas cylinder must always be stored or used in an upright position.



FIXING THE GAS REGULATOR TO THE CYLINDER

Confirm all barbecue control knobs are in the off position.

Hand-tighten the regulator supplied with this barbecue to the gas cylinder by screwing in an anti-clockwise direction.

DO NOT OVER TIGHTEN!

As the regulator is fitted with a soft nose, it should only be tightened a further 1/4 turn after resistance is first felt.

OPERATION



WARNING!

Before proceeding, be certain you understand the safety information contained in this manual.

This barbecue is not designed to be used with more than 66% of the cooking area as a solid plate. Full coverage of plates will cause excessive build-up of heat and damage the barbecue.

- Never leave burners on high for more than 10 minutes unless actually cooking. If the burner makes hissing sounds when lit, it may be burning inside. Turn burner off, allow it to cool and try again.
- Close the gas cylinder valve after each use.

- Never use plastic or glass utensils on the BBQ
- Never use the BBQ in strong winds
- Never lay the gas cylinder down (always keep upright)
- Never allow the flexible gas supply hose or any electrical cord to come in contact with any heated surface of the BBQ.
- Never lean heavily on the side shelves of your BBQ or attempt to transport your BBQ by lifting it from the side shelves.
- Before you start cooking for the first time, clean the BBQ thoroughly with hot soapy water. This is necessary to remove residuals and solvents, oil and grease, which may have remained from the manufacturing process. The hotplate and grill should be thoroughly cleaned in the same manner.



NOTE:

Before using the barbecue for the first time, the barbecue must be lit and burning for 30 minutes on the "low" setting.



IMPORTANT

The regulator supplied with this BBQ may incorporate an Excess Flow Control Safety Device. The Excess Flow Control will activate to prevent gas flow should a regulator malfunction occur. It is important that the BBQ operator understands that all gas valves on the BBQ are closed in the OFF position prior to opening the gas cylinder valve. If the BBQ valves are open prior to opening the cylinder valve, the Excess Flow Control will be activated and prevent the BBQ from being lit. To reset, close the BBQ valves and gas cylinder valve, wait for 1 minute and use correct lighting procedure as detailed below.

LIGHTING THE BBQ

Lighting the BBQ is easy, but must be done with due care.

Make sure that the gas is turned on at the cylinder, or that gas is available to the BBQ. Also, if your BBQ has a roasting hood, ensure that the hood is up.

SPARK IGNITION

Push the knob control in and turn anticlockwise to the high position. You should hear clicking as the igniter creates sparks to light the gas. Once lit, release the igniter button.

DIFFICULTY LIGHTING

If the burner doesn't light first go, check the gas controls and try a couple more times. If the burner still does not light, wait a few minutes to allow the gas to disperse before trying again. If satisfactory operation cannot be achieved, consult your retailer before proceeding.

Note: Failure to follow the lighting procedures correctly can lead to a hazardous condition.

MAIN BURNER AND SIDE BURNER LIGHTING (INTEGRATED IGNITION)

1. Open the lid before igniting the barbecue
2. Check all the knobs are in the "OFF" position
3. Open the gas control valve at the gas cylinder
NOTE: The valves fitted to this BBQ include a safety feature. The valve must be depressed before turning. This feature prevents accidental activation of the knob
4. From the "OFF" position, push in then turn control knob anti-clockwise to the "HI" position until hear a "click" sound
5. Repeat step 4, 3-4 times until the burner is lit
6. If the burner fails to light, turn off and wait for 5 minutes, then begin from step 4
7. Once a burner is lit, similarly light the remaining burners.
8. Turn the knob anticlockwise to adjust the heat from High – Medium – Low to your heat requirement.

FOR MANUAL LIGHTING (MAIN BURNER)



IMPORTANT

Use a match holder and long match stick or BBQ lighter for lighting the BBQ manually to avoid burning your hand.

1. Open the lid before igniting the barbecue.
2. Check all the knobs are in the "OFF" position.
3. Open the gas control valve at the gas cylinder.
4. From the "OFF" position, push in and then turn the control knob anticlockwise to the "HI" position.
5. Hold a lit match (in a match holder) next to one of the main burners. The burner will light from the match.

Once a burner is lit, the burner next to it can be turned on and will light off the lit burner. Repeat until all burners are alight.

Each burner can be adjusted. Turn the knob anticlockwise to adjust the heat from High - medium - Low to your heat requirement.

FOR MANUAL LIGHTING (SIDE BURNER)

1. Turn all knobs to "OFF" then open the LP tank valve. Always keep your face and body as far from the grill as possible when lighting.
2. Raise side burner lid.
3. Push in and then turn control knob anticlockwise to high position.
4. Use a match holder and long match stick or BBQ lighter for lighting the BBQ manually to avoid burning your hand. Place a lit match near the burner until the burner ignites.
5. If burner fails to light, turn off and wait 5 minutes, then try again. If burner still does not light after repeated attempts, call your local dealer for assistance.

REAR BURNER LIGHTING (ELECTRONIC IGNITION)

1. Open the lid before igniting the barbecue.
2. Check all the knobs are in the "OFF" position.
3. Open the gas control valve at the gas cylinder.
4. Operate the rear burner knob in combination with the electronic ignition push button on the side burner table.
5. From the "OFF" position, push in then turn control knob anticlockwise to the "HI" position.
6. Keep the knob pushed in at the "HI" position for 4 seconds whilst pressing the electronic ignition push button.
7. Repeat the steps from beginning, 3-4 times until the burner is lit.
8. Once the rear burner has ignited keep the knob pushed in at the "HI" position for 20 seconds until stabilized then release the rear burner control knob.
9. If the burner fails to light, turn off and wait for 5 minutes, then repeat the steps from beginning.
10. Turn the knob anticlockwise to adjust the heat from High – Medium – Low to your heat requirement.

FOR MANUAL LIGHTING (REAR BURNER)

1. Open the lid before igniting the barbecue.
2. Check all the knobs are in the "OFF" position.
3. Open the gas control valve at the gas cylinder.
4. From the "OFF" position, push in and then turn the rear burner control knob anticlockwise to the "HI" position.
5. Hold a lit match (in a match holder) next to rear burner. The burner will light from the match.
FOR REAR BURNER: LP gas takes longer time to travel from the valve to the rear burner. Keep the knob pushed in at the "HI" position for a further 20 seconds until stabilized, then release the rear burner control knob. Repeat from step 4, 3-4 times until the burner is lit.
6. If the burner fails to light, turn off and wait 5 minutes, then begin from step 4.



IMPORTANT

Keep a spray bottle of soapy water near the gas supply valve and check the connections before each use.



WARNING!

- Do not light the grill if odour of gas is present.
- It is important to ensure that all control valves, including the gas cylinder, are turned off after use.
- When using the rear burner and rotisserie use 1 or 2 of the main burners at the low heat setting if a little extra heat is required.
- Do not use the rear burner in combination with main burners on high heat setting when the hood is closed.
- **Caution / Danger:** Extreme care is required when cooking with hood in closed position. Frequent checks must be undertaken for the heat and temperature to ensure safe cooking.
- Too much heat can cause fire.

TURNING OFF A BURNER

Push in then turn each burner control knob clockwise to the "OFF" position.

TURNING OFF YOUR BARBECUE

When you have finished using your barbecue, turn off the gas at the bottle. Push in and then turn all the control valves fully clockwise to the "OFF" position. Wait until the barbecue is sufficiently cool before replacing the barbecue lid or closing its hood. Once cooled, a protective cover should always be fitted to the barbecue to protect your investment from the ailments when not in use.

WARMING RACK

Warming racks are a convenient way to keep cooked food warm or to warm items such as bread rolls. Always check that your warming rack is properly fitted before use.

GRILL COOKING

The burners heat up the flame tamers underneath the grill, which in turn heats the food on the grill. The natural juices produced during cooking fall onto the flame tamers below and vaporise. The subsequent rising smoke bastes the food, as it travels upwards, imparting that unique barbecue flavour.

FLAT PLATE / FLAT-RIBBED PLATE

The burners heat the griddle plate directly, which then cooks the food on contact. These allow for the cooking of smaller items, such as seafood, which could fall through the spaces of a grill. They are also suitable for cooking items that require high-temperature/ short-duration cooking, such as vegetables and smaller cuts of fish. Similarly, these can be used in exactly the same way as a griddle in the kitchen, for searing steaks, cooking eggs, etc.

DO NOT use both the plate and deep dish at the same time. This will cause your BBQ to overheat and could cause a fire.

COOKING AND USE OF HOOD

Barbecues equipped with a roasting hood give the option of cooking with hood closed to form an 'oven' for roasting food, such as joints of meat, whole chickens, etc.



WARNING!

Cooking with the hood closed and the burners on high creates a fire risk. When the hood is closed, a large amount of heat is trapped inside the barbecue. Thus, it is IMPORTANT to make sure that all the burners are turned to the low position to prevent burning of the food and damaging the barbecue. Avoid lifting the hood unnecessarily as heat is lost every time the hood is opened. Use the temperature gauge to check the heat of the barbecue.

DO NOT ALLOW YOUR BARBECUE TO OVERHEAT. A BARBECUE SHOULD NEVER BE LEFT UNATTENDED WHILE COOKING!

For safety reasons, barbecue plates and grills will not cook as hot towards the front of the barbecue.

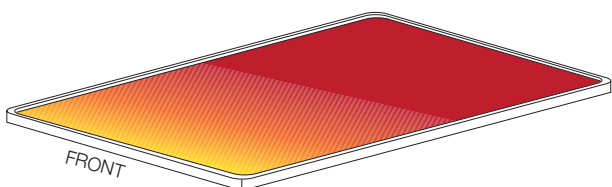

The slightly lower temperature at the front can easily be overcome by rotating the food being cooked around the barbecue plate or grill.

FLARE-UP CONTROL

Flare-ups occur when meat is barbecued, and its fats and juices fall upon the flame tamers. The smoke from some flare-up helps give cooked meat its barbecued flavour, but excessive flare-up will result in meat being burned. To control flare-up, it is advisable to trim away excess fat from meat and poultry before grilling. Also, the burners should always be placed on the low setting during cooking. Finally, extinguish flare-ups by applying baking soda or salt directly onto the flame tamers. Always protect your hands when handling anything near the cooking surface of the barbecue.

If a fat fire should occur in the drip tray, turn all knobs to the off position, turn off the gas at the bottle, and wait for the fire to go out. Do not pull out the drip tray or douse with water.

COOKING USING OPTIONAL ACCESSORIES ROTISSERIE COOKING (OPTIONAL)

1. Carefully remove the cast iron cooking surfaces and the warming rack from the barbecue.
2. Place the flame tamers to the centre of the barbecue body. It is over this area that the meat will be cooked.
3. Slide one of the spit forks onto the spit rod and tighten its thumb screw to secure it into place. Insert the pointed end of the spit rod into the meat being cooked and slide the meat towards the centre of the rod. Make sure the fork is fully into the meat. Slide the other fork onto the rod, into the meat, and tighten the thumb screw once in place. For optimal rotisserie cooking, food must be placed securely onto the middle of the spit rod and balanced so that the rotisserie can rotate freely without interference from any barbecue surfaces. Any loose sections of meat should be secured so they do not hang down and interfere with the rotation of the spit rod.
4. Insert the pointed end of the spit rod into the motor. Lay the other end of the spit rod onto the opposite bracket.
5. Light the barbecue.
6. Turn on the rotisserie motor to begin rotisserie cooking. The hood has been designed so that it may be closed during rotisserie cooking.
7. Always cook foods on the lowest flame setting to avoid burning or overcooking.
8. **DO NOT ALLOW YOUR BARBECUE TO OVERHEAT. A BARBECUE SHOULD NEVER BE LEFT UNATTENDED WHILE COOKING!**
9. If cooking with rotisserie using indirect heat (not using burners

directly under meat - oven style cooking), a baking dish (not supplied on some models) can be placed under the food to catch fats and drippings.

INFRARED REAR BURNER & ROTISSERIE (OPTIONAL)

Preparing your barbecue:

You will need to remove both grill plate and solid plate, also the flame tamers and warming rack. Place these in a safe place for later re-assembly. Place a baking dish (not supplied) onto the burners, the dish should be large and deep enough to capture the excess grease as it falls from the food.

Centrally secure the food with the rotisserie prongs, turning the rotisserie rod by hand to test for balance, adjust the food position if required. Insert pointed end of rod into the motor, test that everything is running correctly.

Using the Rear Burner for roasting on a barbecue can be different depending on our preferences. A suggestion might be to use 1-3 of the main burners to cook the roast and then use the Rear Burner towards the end of the cooking to "brown up" the roast. Using the Rear Burner by itself to do the cooking can take a long time depending on the size of the roast.

Do not use the rear burner in combination with main burners on high heat setting when the hood is closed.



WARNING!

- **Caution / Danger:** Extreme care is required when cooking with hood in closed position. Frequent checks must be undertaken for the heat and temperature to ensure safe cooking.
- Too much heat can cause fire.

Coloured BBQ's are more prone to fading than Black BBQ's. To look after your BBQ, do not cook with the Hood down at High temperature for long periods of time. Use the BBQ cover when BBQ is not being used to protect it from direct sunlight.

TROUBLESHOOTING

BEFORE CALLING FOR SERVICE

If the grill does not function properly, use the following checklist before contacting your dealer for service.

APPLIANCE APPROVED OUTDOOR USE ONLY

USE ONLY THE 5/8" x 18 GAS CONNECTION HOSE AND REGULATOR PROVIDED BY THE MANUFACTURER!

If a replacement is necessary, please contact either our Masport Customer Service Department or your local dealer.

The use of unauthorised parts can create unsafe conditions and environment.

Refer to your Masport warranty card for warranty information.

STORAGE OF THE GRILL

1. Clean the BBQ.
2. Store the BBQ outdoors in a dry, well ventilated area and out of reach of children when LP tank is connected to the grill.
3. Store the BBQ indoors ONLY after the LP tank is turned off and removed, the LP tank must be stored outdoors, out of reach of children, NEVER store the tank in a building, garage or any other enclosed area.
4. If using a cover for your barbecue, check your BBQ every few weeks.

CHECKLIST

Problems	Possible Cause	Solutions
Integrated Ignition		
When push the knob and turn anticlockwise:		
- Won't light	Orifice blocked	Check the orifice for blockage
- No spark	Dirty contacts of the electrode and or loose contacts	Remove the connecting wire, clean and reconnect firmly
- Still no spark	Electrode terminals are damaged	Inspect electrode and replace if damage
- Weak spark	Due to moisture / food residue on the electrodes	Remove the moisture using paper towel / clean the electrode
- Spark at places other than the tip of electrode	Ignition wire damaged	Replace the ignition wire
Electronic Ignition (Rear Burner)		
When push the knob and turn anticlockwise:		
- Won't light	Orifice blocked	Check the orifice for blockage
- No spark	Dirty contacts of the electrode and or loose contacts	Remove the connecting wire, clean and reconnect firmly
- Still no spark	Dirty / loose contacts at the battery	Clean
	Dead / discharged Battery	Replace battery
	Wrong polarity	Check and insert the battery correctly
- Still no spark	Circuit incomplete due Loose contacts at the ignition module	Re-assemble the ignition module make sure the assembly is tight and makes a complete circuit
- Still no spark	Electrode terminals are damaged	Inspect electrode and replace if damage
- Weak spark	Due to moisture / food residue on the electrodes	Remove the moisture using paper towel / clean the electrode
- Spark at places other than the tip of electrode	Ignition wire damaged	Replace the ignition wire
Burner can't light by match		
	No gas	Open the LP tank valve
	Gas flow is not smooth	Clear burner tubes
	Incorrect assembly between burner and valve	Re-assemble
Yellow or orange flames, with gas odour		
	Incomplete combustion	Check the burner inlet for obstruction such as spiders Check air shutter for correct adjustment Check for the source
Low heat with knob in "high" position		
	Gas hose bent or kinked	Straighten
	Burner or orifice blocked	Clear
	Low gas pressure	Check Cylinder/ Regulator (refer to pg. 15)
	Grill not preheated	Preheat the grill for 15 minutes
Flare up		
	Excessive meat fat	Cut off fat before grilling
	Over high temperature	Adjust
	Grease deposit	Clean
Flame out		
	Over high winds	Find a less windy place
Flame lifting		
	Over high gas pressure	Call the gas dealer
Flashback		
	Burner port blocked	Clean
Grease fire		
	Grease accumulated in food	Turn off knobs, LP tank valve, leave lid open, let fire burn out. Clean the grill when cool.

CARE AND MAINTENANCE

Regularly clean your barbecue between uses and especially after extended periods of storage. Ensure the barbecue and its components are sufficiently cool before cleaning. Do not leave the barbecue exposed to outside weather conditions or stored in damp, moist areas.

- Never douse the barbecue with water when its surfaces are hot.
- Never handle hot parts with unprotected hands.

Whilst our products are made to the highest standards and all care is taken to make them as weather proof as possible, we cannot accept responsibility for rust occurring on exposed metal parts unless this is a result of faulty manufacture of parts.

In order to extend the life and maintain the condition of your barbecue, we strongly recommend that the unit is covered when not in use, especially during the winter months.

STAINLESS STEEL CARE AND CLEANING ADVICE

Cleanliness and stainless steel are closely related. Stainless steel performs best when clean - cleanliness is essential for maximum resistance to corrosion and to maintain the good looks and life of your BBQ.

TYPES OF SURFACE CONTAMINANTS

Fingerprints and Stains

Fingerprints and mild stains resulting from normal use are the most common surface contaminates. They can be removed with a glass cleaner or with a soft rag. This should be followed by a thorough warm water rinse.

DIRT

Like any surface that is exposed to the environment especially in coastal areas, stainless steel can get dirty. Cleaning with warm water with or without a gentle detergent is sufficient. Next in order are mild non-scratching abrasive powders such as typical household cleaners. These can be used with warm water, nylon bristle brushes, sponges, or clean cloths. Carbon steel brushes or steel wool should be avoided as they may leave particles embedded on the surface which can lead to RUSTING. Cleaning should always be followed by rinsing in clean hot water.

GREASE

Grease may soil stainless steel surfaces in food preparation. These soils may be mildly corrosive if left or may not allow the surface to maintain passivity, and so regular removal is a necessity for the appearance.

TYPES OF CLEANERS AND METHODS

Consider the possibility of scratching and the potential for post-cleaning corrosion caused by incompletely removed cleaners. Avoid using abrasive cleaners unless absolutely necessary.

CLEAN WATER AND WIPE

A soft cloth and clean warm water should always be the first choice for mild stains and loose dirt and soils. A final rinse with clean water and a dry wipe will complete the process and eliminate the possibility of water stains.

HOUSEHOLD CLEANERS

Household cleaners fall into two categories: detergent (non-abrasive) and abrasive cleaners. Abrasive cleaners are more effective but introduce the possibility of scratching the surface. A neutral cleaner low in chloride is essential. The cleaning method generally employed with these cleaners is to apply them to the stainless surface and follow by cloth wiping in the direction of the grain or polish lines (not across them). The cleaned surface should be thoroughly rinsed with clean water and wiped dry with a soft cloth if water streaking is a consideration.

CARE OF STAINLESS STEEL IN YOUR BBQ

Your BBQ features Stainless Steel components. All Stainless Steel grades require a level of care and protection to retain their appearance. Stainless Steels are not immune to corrosion and neither are they maintenance-free, contrary to popular public perception. Even the highest marine grades of Stainless Steel require frequent cleaning to avoid oxidation and other corrosive issues.

Modern tastes dictate that your BBQ features Stainless Steel with a brushed finish. This brushed finish is attained by running Stainless Steel sheets through an abrasive process that removes the mirror finish and leaves the brushed finish. Brushed-finish Stainless Steel requires frequent cleaning and care, to maintain its quality of appearance. Without adequate care it is realistic to expect that it will show signs of corrosion in time.

Stainless steel is definitely not a maintenance-free material. Cleanliness and Stainless Steel are closely related.

The cleaner stainless steel can be kept while in storage or during use, the greater the assurance of optimum corrosion resistance. In order to maintain the good looks and life of your BBQ, follow these summary tips on the care of stainless steel:

- When new or when cleaned and dried, we recommend the owner apply a thin coat of Olive Oil to stainless steel surfaces which should then be polished in. The Olive Oil will help greatly in protecting the stainless steel from corrosive contaminants and assisting removal of finger prints and other marks, keeping the appearance of the stainless steel in new condition. The Olive Oil coating also makes further polishing easier.
- Use clean, soft cloths or sponges to clean your grill.
- Carbon steel brushes or steel wool should never be used.
- Do routine cleaning of exposed surfaces.
- After cleaning, rinse thoroughly with water.
- Cleaning with chloride-containing detergents must be avoided.
- On polished finishes, rubbing or wiping should be done in the direction of the polish lines, NOT across them.
- Care must be taken when cleaning the fascia. Printed information may be erased with heavy cleaning.

CAST IRON COOKING SURFACES

Before cooking with the grill, flat plate or deep dish (if supplied with your BBQ) clean these with hot soapy water to remove any oil or residue from the packaging or manufacturing process. Wash with clean water and let the plates dry naturally. Prior to lighting your BBQ place them back into the BBQ. Then after lighting your BBQ, let the plates warm up slowly over a period of 30 minutes, during this time increasing the heat. You will notice slight vapors rise from the plates, this is natural as residues are burned off. Turn off your BBQ to allow the plate to cool slightly. The plates can now be prepared with the addition of cooking oil. Take care that the plates are not at a temperature where adding the oil will cause a hazard. Brush the oil over the plate, allowing the oil to be absorbed into the surface. Allow the plate to fully cool, then remove any excess oil. The BBQ is now ready. Repeat the above to keep the plate and grill in a ready condition after each BBQ session.

PORCELAIN ENAMEL COOKING SURFACES

Porcelain Enamel surfaced items should be treated with care and should not be cleaned with an abrasive cleaner or scratchy cleaning item. Surfaces will crack or chip if hit or dropped. Porcelain Enamel surfaces should NOT be regarded as 'Non-stick', use of cooking oil is required as normal. Food will likely stick to an overheated or un-oiled enamel surface. The surface will be more easily cleaned by first soaking overnight.

BURNER MAINTENANCE

Provided that they are operating correctly, in normal usage, burning off the residue after cooking will keep the burners clean. The burners should be removed and cleaned annually, or whenever heavy build-up is found, to ensure that there are no signs of

blockage (debris, insects) in either the burner portholes, the primary air inlet, or the neck of the stainless steel burners. Use a pipe cleaner to clear obstructions. When refitting the burners, be careful to check they are positioned as follows. The neck of the burner fits over the valve outlet, the top flaps of the gas collector boxes fit over the top surfaces of the burners.

BURNER MAINTENANCE AND REPLACEMENT

Both the stainless steel burners and flame tamers do have a defined operating lifespan, these products are often exposed to cooking marinades and extreme heat in an area of the barbecue which can be neglected during regular cleaning.

Replacement parts are available from your local barbecue dealer.

SPIDER AND INSECT WARNING!

Spiders and insects can nest in the burners of the grill and cause the gas to flow from the front of the burner. This is a very dangerous condition, which can cause a fire to occur, thereby damaging the grill and making it unsafe to operate.

WHEN TO LOOK FOR SPIDERS

You should inspect the burners at least once a year or immediately after any of the following conditions occur:

- The smell of gas in conjunction with the burner flames appearing yellow.
- The BBQ does not reach temperature.
- The BBQ heats unevenly.
- The burners make popping noises.

PRIMARY AIR INLET WIDTH REQUIREMENT:

For 4 burner barbecues:

- Width for each side: 5.5~6.5mm
- Total width for two sides: 11~13mm

For 6 burner barbecues:

- Width for each side: 2~2.5mm
- Total width for two sides: 4~5mm

HOW TO ADJUST AIR INLET:

Adjust the primary air inlet width according to the pictures below.

(Burner image shown below is for illustration purpose only)

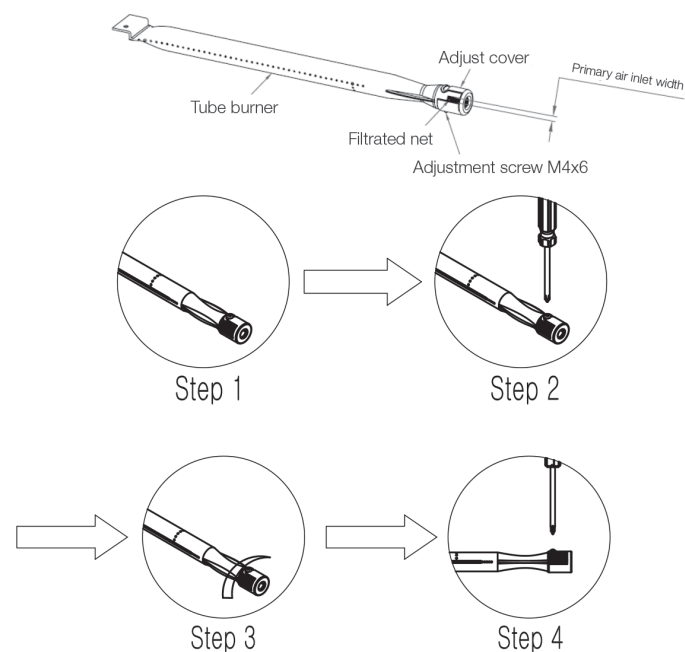

ELECTRODE SETTING

Electrode should have a sparking gap of approximately 4-5mm. The distance away from the face of the rear burner should less than 9mm.

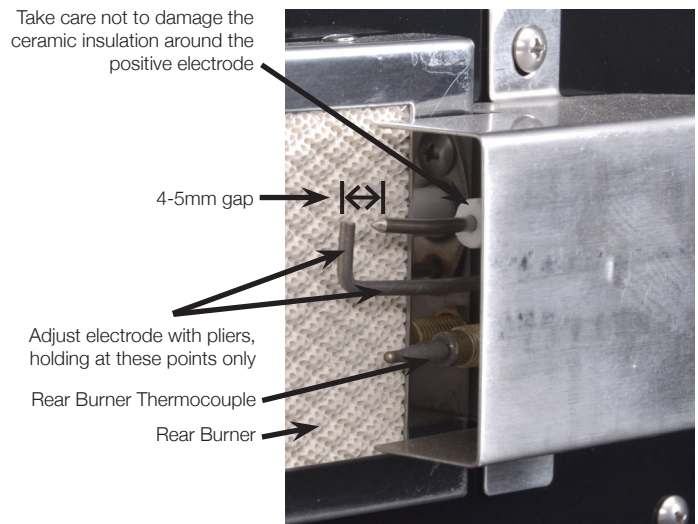

NOTE:

Cooking with the rear burner allows the food to “self baste” as it is turned, any excess juices will fall into the baking dish.

Your BBQ is safe to use with the hood closed however the internal temperature must be checked. Cooking with the rear burner is designed to be a slow cooking process, this allows the food to be succulent. External temperatures and breeze will effect the internal temperature, as a guide this should be around 165°C to 180°C.



NOTE:

- Vegetables and herbs can be placed into the baking dish, these items will cook/flavour the food at the same time.
- When using the rear burner and rotisserie use 1 or 2 of the main burners at the low heat setting if a little extra heat is required.



WARNING!

- Do not use the rear burner in combination with main burners on high heat setting when the hood is closed.
- **Caution / Danger:** Extreme care is required when cooking with hood in closed position. Frequent checks must be undertaken for the heat and temperature to ensure safe cooking.
- Too much heat can cause fire.

DRIP TRAY

After every use, check the drip tray, drip pan, and foil pan for fat build-up. Failure to maintain these areas could result in a fat fire or excessive flare up. This can severely damage your barbecue and is not covered by the warranty.

BARBECUE BODY



WARNING!

Not cleaning the barbecue can pose a fire risk!

Regularly remove excess grease or fat from the barbecue body with a soft plastic or wooden scraper. It is not necessary to remove all the grease from the body. If you need to clean fully, use hot soapy water and a cloth, or nylon-bristled brush only. Remove cooking surfaces and burners before full cleaning. Do not immerse the gas controls or manifold in water. Check burner operation after carefully refitting into body.

FIXINGS

All screws and bolts, etc. should be checked and tightened on a regular basis.



END OF THE COOKING SESSION

After each cooking session, turn the BBQ burners to the “HIGH” position and burn off for 5 minutes. This procedure will burn off food residue, thus making cleaning easier.

STORAGE

Store your barbecue in a cool dry place. Cover the burners with aluminium foil in order to prevent insects or other debris from collecting in burner holes. A protective cover should always be fitted to the barbecue to protect your investment from the elements when not in use. If the barbecue is to be stored indoors, the gas bottle must be disconnected and left outside. The gas bottle should always be stored outside, in a dry, well-ventilated area, away from any sources of heat or ignition. Do not let children tamper with the bottle.

To protect your investment it is recommended that BBQs are protected by a suitable BBQ cover. But please note that prior to using a protective cover, the BBQ should always be cool, cleaned of any surface contaminant or dirt and be thoroughly dry. Failure to follow this information can lead to a BBQ cover being a corrosion breeder rather than a protective tool.



NOTE:

If leaving your BBQ covered for long periods, occasionally check for corrosion and insect habitation. Oil surfaces for extra protection.

SERIAL NUMBER

The serial number of your barbecue is located on the inside of the cabinet either on the right hand door or the side panel. If you do require any further assistance with your barbecue from your local dealer or Masport, please have this serial number handy as it will quickly allow us to identify the barbecue.





Masport®

Masport Limited
320 Ti Rakau Drive, East Tamaki
Auckland 2013
New Zealand
P: 0800 627 767

Masport Australia Pty Limited
27 Commercial Drive, Dandenong South
Braeside, South Victoria 3175
Australia
P: 1300 366 225

Copyright® Masport Limited