

Haier

Ceramic Hob

Instruction Manual / Installation Manual

MODEL

HCE302TB3

HCE604TB3

HCE905TB3

Safety and Warnings

Your safety is important to us. Please read this information before using your cooktop.

INSTALLATION



WARNING: Electrical Shock Hazard

- Disconnect the appliance from the mains electricity supply before carrying out any work or maintenance on it.
- Connection to a good earth wiring system is essential and mandatory.
- Alterations to the domestic wiring system must only be made by a qualified electrician.
- Failure to follow this advice may result in electrical shock or death.



WARNING: Cut Hazard

- Take care - panel edges are sharp.
- Failure to use caution could result in injury or cuts.

Important Safety Instructions

- Read these instructions carefully before installing or using this appliance.
- No combustible material or products should be placed on this appliance at any time.
- Please make this information available to the person responsible for installing the appliance as it could reduce your installation costs.
- In order to avoid a hazard, this appliance must be installed according to these instructions for installation.
- This appliance is to be properly installed and earthed only by a suitably qualified person.
- This appliance should be connected to a circuit which incorporates an isolating switch providing full disconnection from the power supply.
- Failure to install the appliance correctly could invalidate any warranty or liability claims.

OPERATION AND MAINTENANCE



WARNING: Electrical Shock Hazard

- Do not cook on a broken or cracked cooktop. If the cooktop surface should break or crack, switch the appliance off immediately at the mains power supply (wall

switch) and contact a qualified technician.

- Switch the cooktop off at the wall before cleaning or maintenance.
- Failure to follow this advice may result in electrical shock or death.

WARNING:Health Hazard

- This appliance complies with electromagnetic safety standards.

WARNING:Hot Surface Hazard

- During use, accessible parts of this appliance will become hot enough to cause burns.
- Do not let your body, clothing or any item other than suitable cookware contact the ceramic glass until the surface is cool.
- Metallic objects such as knives, forks, spoons and lids should not be placed on the hob surface since they can get hot
- Keep children away.
- Handles of saucepans may be hot to touch. Check saucepan handles do not overhang other cooking zones that are on. Keep handles out of reach of children.
- Failure to follow this advice could result in burns and scalds.

WARNING:Cut Hazard

- The razor-sharp blade of a cooktop scraper is exposed when the safety cover is retracted. Use with extreme care and always store safely and out of reach of children.
- Failure to use caution could result in injury or cuts.

Important Safety Instructions

- Never leave the appliance unattended when in use. Boilover causes smoking and greasy spillovers that may ignite.
- Never use your appliance as a work or storage surface.
- Never leave any objects or utensils on the appliance.
- Never use your appliance for warming or heating the room.
- After use, always turn off the cooking zones and the cooktop as described in this manual (i.e. by using the touch controls).
- Do not allow children to play with the appliance or sit, stand, or climb on it.

- Do not store items of interest to children in cabinets above the appliance. Children climbing on the cooktop could be seriously injured.
- Do not leave children alone or unattended in the area where the appliance is in use.
- Children or persons with a disability or lack of experience and knowledge, which limits their ability to use the appliance should have a responsible and competent person to instruct them in its use. The instructor should be satisfied that they can use the appliance without danger to themselves or their surroundings.
- Do not repair or replace any part of the appliance unless specifically recommended in the manual. All other servicing should be done by a qualified technician.
- Do not use a steam cleaner to clean your cooktop.
- Do not place or drop heavy objects on your cooktop.
- Do not stand on your cooktop.
- Do not use pans with jagged edges or drag pans across the Ceramic glass surface as this can scratch the glass.
- Do not use scourers or any other harsh abrasive cleaning agents to clean your cooktop, as these can scratch the Ceramic glass.
- If the supply cord is damaged, it must be replaced by the manufacturer, its service agent or similarly qualified persons in order to avoid a hazard.
- This appliance is not intended for use by persons (including children) with reduced physical, sensory or mental capabilities, or lack of experience and knowledge, unless they have been given supervision or instruction concerning use of the appliance by a person responsible for their safety.
- Children should be supervised to ensure that they do not play with the appliance.
- Cleaning and user maintenance shall not be made by children without supervision.
- The appliance is not intended to be operated by means of an external timer or separate remote-control system.

CAUTION: The cooking process has to be supervised. A short term cooking process has to be supervised continuously.

Product Dimensions

HCE302TB3

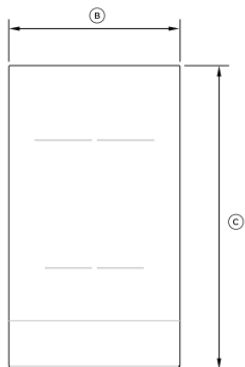

PLAN

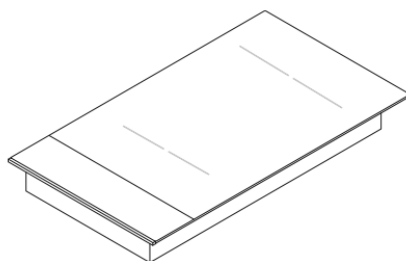

ISOMETRIC

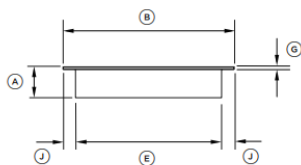

FRONT

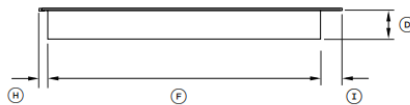

PROFILE

HCE302TB3

PRODUCT DIMENSIONS	HCE302TB3
	mm
A Overall height of cooktop	52
B Overall width of cooktop	288
C Overall depth of cooktop	520
D Height of chassis	48
E Width of chassis	260
F Depth of chassis	492
G Height of cooktop glass	4
H Depth of front overhang of cooktop glass	14
I Depth of rear overhang of cooktop glass	14
J Depth of side overhang of cooktop glass	14

HCE604TB3

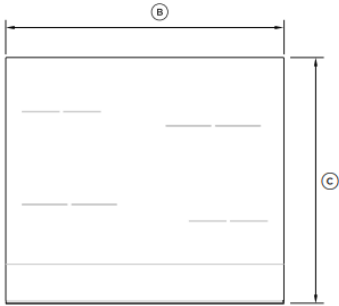

PLAN

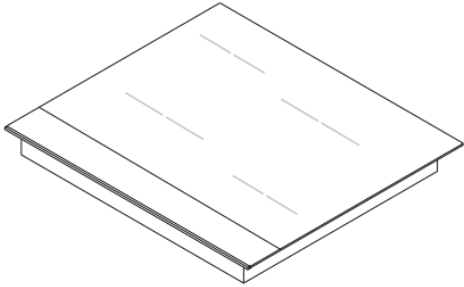

ISOMETRIC

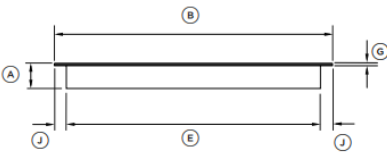

FRONT

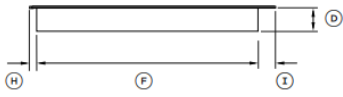

PROFILE

HCE604TB3

PRODUCT DIMENSIONS	HCE604TB3
	mm
A Overall height of cooktop	52
B Overall width of cooktop	590
C Overall depth of cooktop	520
D Height of chassis	48
E Width of chassis	552
F Depth of chassis	482
G Height of cooktop glass	4
H Depth of front overhang of cooktop glass	19
I Depth of rear overhang of cooktop glass	19
J Depth of side overhang of cooktop glass	19

HCE905TB3

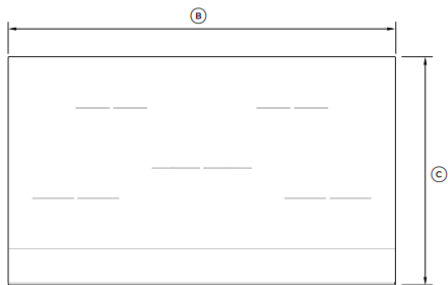

PLAN

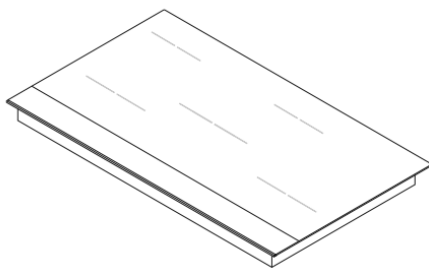

ISOMETRIC

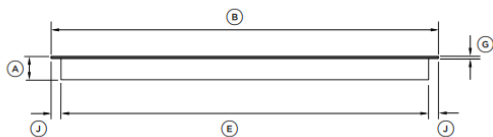

FRONT



PROFILE

HCE905TB3

PRODUCT DIMENSIONS	HCE905TB3
	mm
A Overall height of cooktop	52
B Overall width of cooktop	900
C Overall depth of cooktop	520
D Height of chassis	48
E Width of chassis	862
F Depth of chassis	482
G Height of cooktop glass	4
H Depth of front overhang of cooktop glass	19
I Depth of rear overhang of cooktop glass	19
J Depth of side overhang of cooktop glass	19

Installation

Cutout Dimensions

Cut out the work surface according to the sizes shown in the drawing.

For the purpose of installation and use, a minimum of 5 cm space shall be preserved around the hole.

Be sure the thickness of the work surface is at least 18 mm. As shown below:

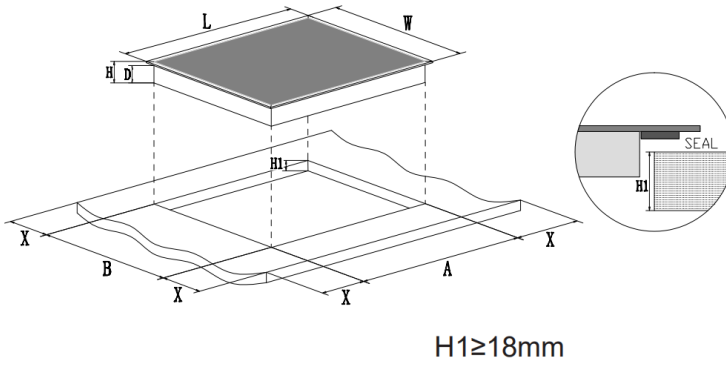

Model	L (mm)	W (mm)	H (mm)	D (mm)	A (mm)	B (mm)	X (mm)
HCE302TB3	288	520	52	48	268^{+5}	500^{+5}	47 min
HCE604TB3	590	520	52	48	560^{+5}	490^{+5}	50 min
HCE905TB3	900	520	52	48	870^{+5}	490^{+5}	50 min

Clearance Dimensions

Under any circumstances, make sure the ceramic cooker hob is well ventilated and the air inlet and outlet are not blocked. Ensure the ceramic cooker hob is in good work state. Please see clearance dimensions required below.

 e: The minimum distance between the hotplate and the range hood above the hotplate should be at least 600 mm(A). In the case of an oven installation under the cooktop, there must be a minimum 10 mm air gap at the front of the cooktop, between the benchtop & the oven door (as shown in the diagram below)

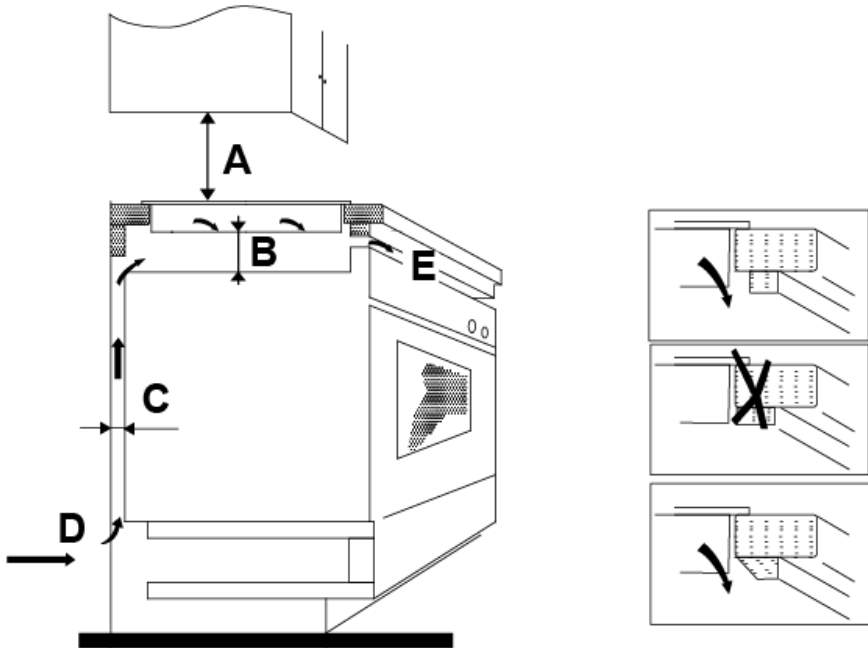

A(mm)	B(mm)	C(mm)	D	E
600 min	50 min	30 min	Air intake	Air exit 10 mm min

Before you install the cooktop

1. The ceramic cooker hob must be installed by qualified personnel or technicians.
2. The benchtop is square and level, and no structural members interfere with space requirements.
3. The benchtop is made of a heat-resistant material.
4. The cooktop will not be installed directly above a dishwasher, fridge, freezer, washing machine or clothes dryer, as the humidity may damage the cooktop.
5. The installation will comply with all clearance requirements and applicable standards and regulations.
6. You use heat-resistant and easy-to-clean finishes (such as ceramic tiles) for the wall surfaces surrounding the cooktop.
7. This ceramic can be connected only to a supply with system impedance no more than 0.427 ohm. In case necessary, please consult your supply authority for system impedance information.
8. To avoid any damage, the sandwich layer and adhesive must be resistant to heat.

When you have installed the cooktop

1. The power supply cable is not accessible through cupboard doors or drawers.
2. There is adequate flow of fresh air from outside the cabinetry to the base of the cooktop.
3. The isolating switch is easily accessible by the customer.

Fastening the cooktop to the bench

1. Turn the cooktop upside down and place it on a soft & stable surface, you can use the packaging.
2. Mount the supplied brackets (A) and tighten the screws (B) onto the cooktop, as shown in below image.
3. Turn around the cooktop and place it into the cutout, press it down to secure it firmly.

CAUTION: While pressing the unit into the cutout, please pay attention to use the top surface of glass rather than the edges to avoid your fingers getting trapped in between.

Notes:

1. **Foam seal** is already applied on the perimeter of glass bottom surface, it's not part packaging, please **do not remove**.
2. Minimum benchtop thickness required is 18 mm for the retaining bracket to function adequately.

A	B	C	D
screw	bracket	Screw hole	Chassis

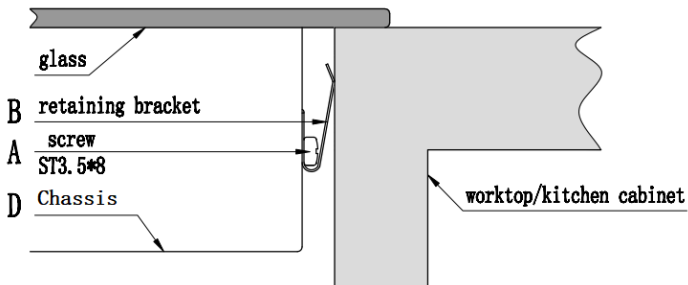
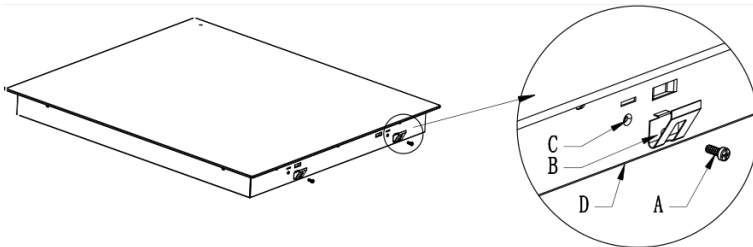

Connecting the cooktop to the mains power supply

IMPORTANT!

- **This cooktop must be connected to the mains power supply only by a suitably qualified person.**
- **This cooktop must be earthed.**
- Before connecting the cooktop to the mains power supply, check that:
 - The domestic wiring system is suitable for the power drawn by the cooktop
 - The voltage corresponds to the value given on the rating plate
 - The power supply cable sections can withstand the load specified on the rating plate.
- To connect the cooktop to the mains power supply, do not use adapters, reducers, or branching devices, as they can cause overheating and fire.
- The power supply cable must not be kinked and must not touch any hot parts.
- If the cable is damaged or needs replacing, this should be done by an after-sales technician using the proper tools, so as to avoid any accidents.
- If the appliance is being connected directly to the mains supply, an omnipolar circuit breaker must be installed with a minimum gap of 3mm between the contacts.
- The installer must ensure that the correct electrical connection has been made and that it complies with safety regulations.
- The cable must be checked regularly and only replaced by a properly qualified person.
- The power supply should be connected in compliance with the relevant standard, or a single-pole circuit breaker. The method of connection is shown below.

IMPORTANT!

Check with an electrician whether the domestic wiring system is suitable without alterations. Any alterations must only be made by a qualified electrician.

Single phase connection

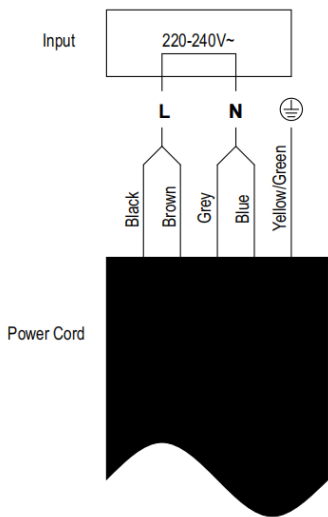

Two phase connection

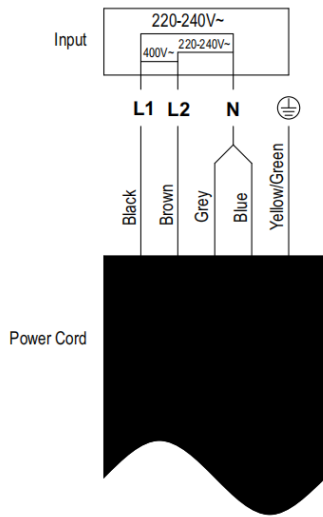

Model: HCE905TB3 / HCE604TB3

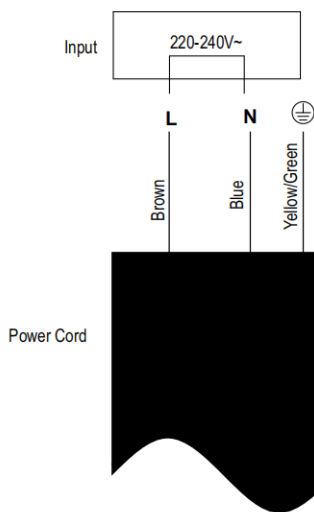

Model: HCE302TB3

Product Overview

Top View HCE302TB3

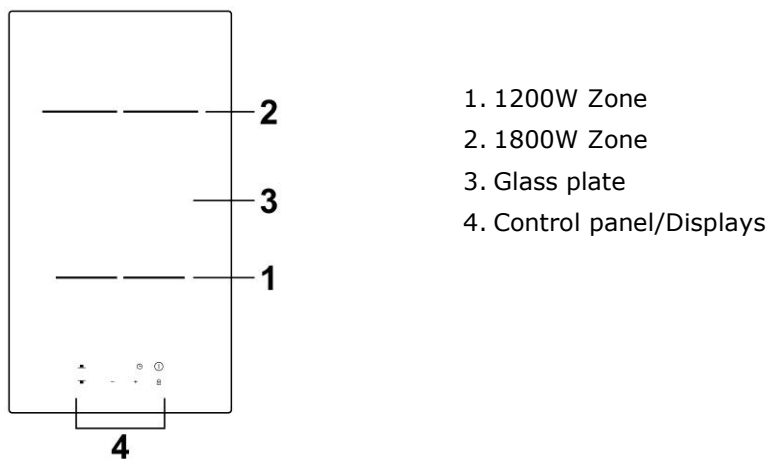

Control Panel

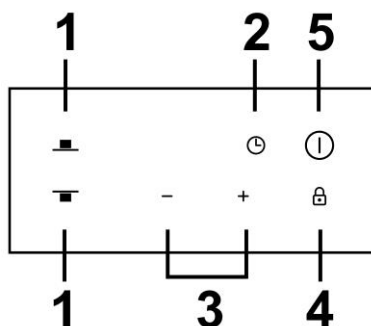

1. Heating zone selection controls
2. Timer control
3. Power / Timer setting controls
4. Keylock control
5. ON/OFF control

Top View HCE604TB3

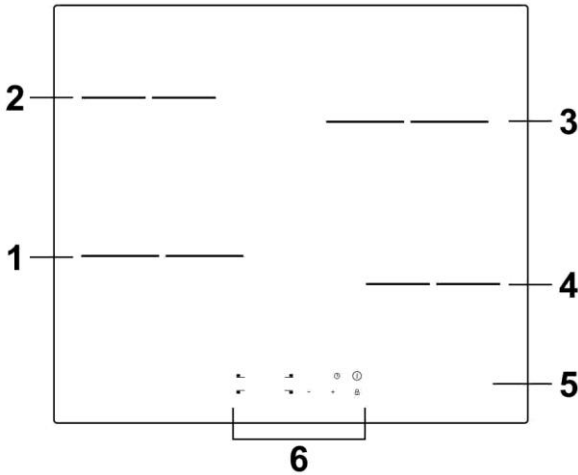

1. 1800W Zone
2. 1200W Zone
3. 1800W Zone
4. 1200W Zone
5. Glass plate
6. Control panel / Displays

Control Panel

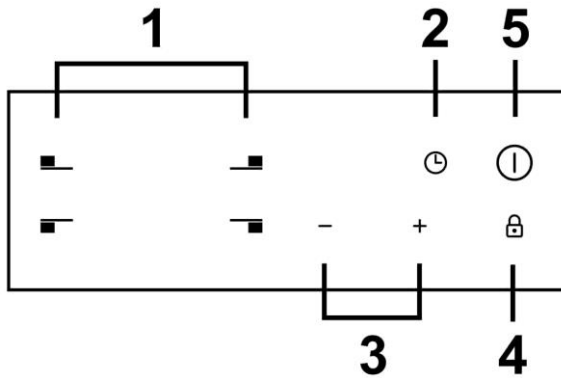

1. Heating zone selection controls
2. Timer control
3. Power / Timer setting controls
4. Keylock control
5. ON/OFF control

Top View HCE905TB3

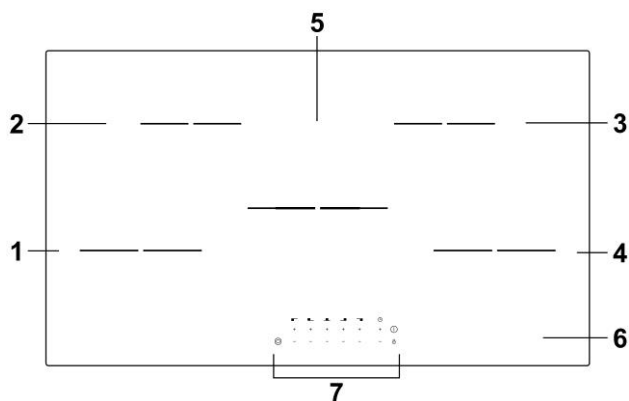

1. 1800W Zone
2. 1200W Zone
3. 1200W Zone
4. 1800W Zone
5. 2200/1000 W zone
6. Glass plate
7. Control panel / Displays

Control Panel

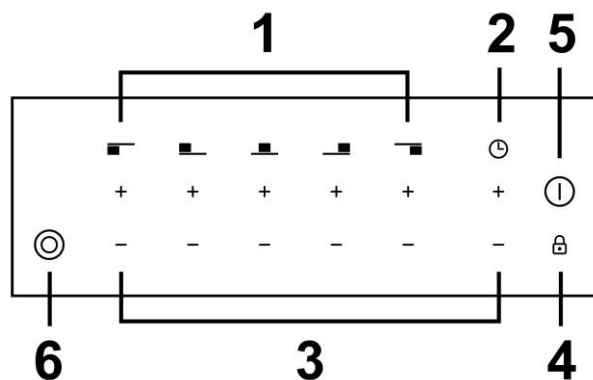

1. Heating zone selection controls
2. Timer control
3. Power / Timer setting controls
4. Keylock control
5. ON/OFF control
6. Dual Zone control

Product Information of Ceramic Hob

- The microcomputer ceramic cooker hob can meet different kinds of cuisine demands because of resistance wire heating, micro-computerized control and multi-power selection, really the optimal choice for modern families. The ceramic cooker hob centers on customers and adopts personalized design. The hob has safe and reliable performances, making your life comfortable and enabling to fully enjoy the pleasure from life.
- Ceramic hob cooking is based on infrared heating technology, the nickel chrome wires of the hob would radiate heat and give out the infrared to warm up the food. The ceramic cooker hob centers on customers and adopts personalized design. The hob has safe and reliable performances, making your life comfortable and enabling to fully enjoy the pleasure from life.
- Ceramic hobs do not pick pot. You can use any kind of pot or pan, such as copper pots, wok, stainless steel, cookware, glass pot, casserole and ceramic pot.



Before Using Your New Ceramic Hob

- Read this guide, taking special note of the 'Safety Warnings' section.
- Remove any protective film that may still be on your Induction and ceramic cooker.

Using the Touch Controls

- The controls respond to touch, so you don't need to apply any pressure.
- Use the ball of your finger, not its tip.
- You will hear a beep each time a touch is registered.
- Make sure the controls are always clean, dry, and that there is no object (e.g. a utensil or a cloth) covering them. Even a thin film of water may make the controls difficult to operate.

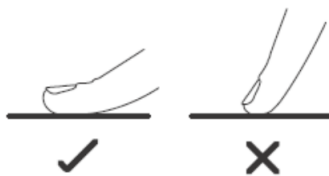

Using your Ceramic Hob

To start cooking

- After power on, the buzzer beeps once, all the indicators light up for 1 second then go out, indicating that the ceramic hob has entered the state of standby mode.

1. Touch the ON/OFF  control, all the indicators show "--" or "- -", indicating that the ceramic hob has entered the state of standby mode.



2. Place a suitable pan on the cooking zone that you wish to use.
 - Make sure the bottom of the pan and the surface of the cooking zone are clean and dry.

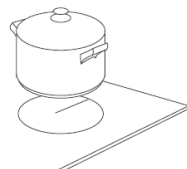



3. Touching the heating zone selection control, and a indicator next to the key will flash





4. Set a power level by touching the "-", "+",

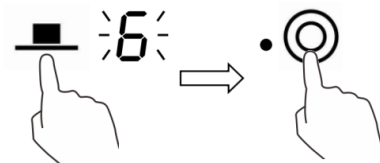

- a. If you don't select a heat zone within 1 minute, the ceramic hob will automatically switch off. You will need to start again at step 1.
- b. You can modify the heat setting at any time during cooking.

Active Dual Ring: Touch the dual zone select control , then the indicator of this zone will flash. activating double zone by pressing  for once.



Turn off the dual zone zone, by press the zone select control accordingly and then press the .

When you have finished cooking

1. Touching the heating zone selection control that you wish to switch off.



2. Turn the cooking zone off by touching the leftest point for a while.



3. Turn the whole cooktop off by touching the "ON/OFF" control.



4. Beware of hot surfaces

“H” will show which cooking zone is hot to touch. It will disappear when the surface has cooled down to a safe temperature. It can also be used as an energy saving function if you want to heat further pans, use the cooking zone that is still hot.



Locking the Controls

- You can lock the controls to prevent unintended use (for example children accidentally turning the cooking zones on).
- When the controls are locked, all the controls except the ON/OFF control are disabled.

To lock the controls



Touch hold the keylock control . The timer indicator will show "Lo".



To unlock the controls

1. Make sure the ceramic hob is turned on.
2. Touch and hold the keylock control for 3 seconds.
3. You can now start using your ceramic hob.



When the hob is in the lock mode, all the controls are disabled except the ON/OFF  , you can always turn the ceramic hob off with the ON/OFF  control in an emergency, but you shall unlock the hob first in the next operation

Over-Temperature Protection

A temperature sensor equipped can monitor the temperature inside the ceramic hob. When an excessive temperature is monitored, the ceramic hob will stop operation automatically.

Residual Heat Warning

When the hob has been operating for some time, there will be some residual heat. The letter " H "appears to warn you to keep away from it.

Auto Shutdown

Another safety feature of the hob is auto shut down. This occurs whenever you forget to switch off a cooking zone. The default shutdown times are shown in the table below:

Power level	1	2	3	4	5	6	7	8	9
Default working timer (hour)	8	8	8	4	4	4	2	2	2

Using the Timer

You can use the timer in two different ways:

1. You can use it as a minute minder. In this case, the timer will not turn any cooking zone off when the set time is up.
 2. You can set it to turn one cooking zone off or more than one after the set time is up.
- You can set the timer for up to 99 minutes.

Using the Timer as a Minute Minder

If you are not selecting any cooking zone

1. Make sure the cooktop is turned on.
Note: you can use the minute minder even if you're not selecting any cooking zones.
2. Touch timer control , The minder indicator will start flashing and "30" will show in the timer display. 
3. Adjust the timer setting by touch the "-", "+". The minute minder indicator will start flashing and will show in the timer display.

Hint: Touch the "-" or "+" control of the timer once to decrease or increase by 1 minute.

Touch and hold the "-" or "+" control of the timer to decrease or increase by 10 minutes.

If the setting time exceeds 99 minutes, the timer will automatically return to 0 minute.

4. Touch the 'Timer', the timer is canceled, and the "--" will show in the minute display.

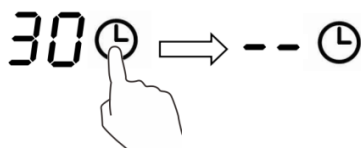

5. When the time is set, it will begin to count down immediately. The display will show the remaining

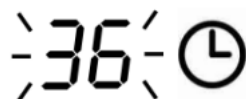

time and the timer indicator will flash for 5 seconds.

6. Buzzer will beep for 30 seconds and the timer indicator shows "--" when the set time finished.

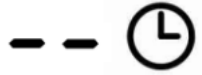

Setting the timer to turn one cooking zone off

1. Touching the heating zone selection control that you want to set the timer for. (e.g. zone 1#)



2. Touch timer control, The minder indicator will start flashing and "30" will show in the timer display.



3. Set the time by touching the "-" or "+" control of the timer

Hint: Touch the "-" or "+" control of the timer once will decrease or increase by 1 minute.

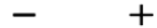

Touch and hold the "-" or "+" control of the timer will decrease or increase by 10 minutes.



4. Touching the heating zone selection control, and then touch the "Timer", the timer is cancelled, and the "--" will show in the minute display.

5. When the time is set, it will begin to count down immediately. The display will show the

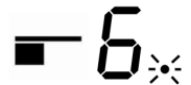

Remaining time and the timer indicator flash for 5 seconds.

NOTE: The red dot next to power level indicator will illuminate indicating that zone is selected.

6. When cooking timer expires, the corresponding cooking zone will be automatically switch off and show "H".



Setting the timer to turn more than one cooking zone off

1. If more than one heating zone use this function, the timer indicator will show the shortest time.

(e.g. zone 1# setting time of 3 minutes, zone 2# setting time of 6 minutes, the timer indicator shows "3".)

NOTE: The flashing red dot next to power level indicator means the timer indicator is showing time of the heating zone.

If you want to check the set time of other heating zone, touch the heating zone selection control. The timer will indicate its set time.

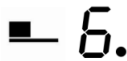
 (set to 6 minutes)

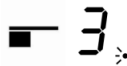
 (set to 3 minutes)



2. When cooking timer expires, the corresponding cooking zone will be switch off automatically and show "H" .



NOTE: If you want to change the time after the timer is set, you have to start from step 1

Cookware

Do not use cookware with jagged edges or a curved base.



Make sure that the base of your pan is smooth, sits flat against the glass, and is the same size as the cooking zone. Always centre your pan on the cooking zone.

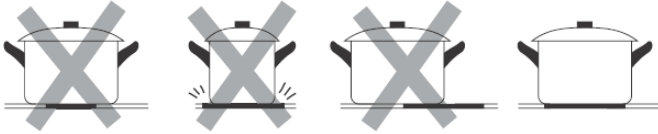

Always lift pans off the ceramic hob – do not slide, or they may scratch the glass.

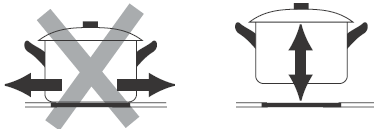

Cooking Guidelines

Cooking Tips

- Using a lid will reduce cooking times and save energy by retaining the heat.
- Minimise the amount of liquid or fat to reduce cooking times.
- Start cooking on a high setting and reduce the setting when the food has come to the boil or heated through.

Simmering, cooking rice

- Simmering occurs below boiling point, at around 85°C, when bubbles are just rising occasionally to the surface of the cooking liquid. It is the key to delicious soups and tender stews because the flavours develop without overcooking the food. You should also cook egg-based and flourthickened sauces below boiling point.
- Some tasks, including cooking rice by the absorption method, may require a setting higher than the lowest setting to ensure the food is cooked properly in the time recommended.

Searing steak

To cook juicy flavoursome steaks:

1. Stand the meat at room temperature for about 20 minutes before cooking.
2. Heat up a heavy-based frying pan.
3. Brush both sides of the steak with oil. Drizzle a small amount of oil into the hot pan and then lower the meat onto the hot pan.
4. Turn the steak only once during cooking. The exact cooking time will depend on the thickness of the steak and how cooked you want it. Times may vary from about 2 – 8 minutes per side. Press the steak to gauge how cooked it is – the firmer it feels the more 'well done' it will be.
5. Leave the steak to rest on a warm plate for a few minutes to allow it to relax and become tender before serving.

For stir-frying

1. Choose a ceramic compatible flat-based wok or a large frying pan.
2. Have all the ingredients and equipment ready. Stir-frying should be quick. If cooking large quantities, cook the food in several smaller batches.
3. Preheat the pan briefly and add two tablespoons of oil.
4. Cook any meat first, put it aside and keep warm.
5. Stir-fry the vegetables. When they are hot but still crisp, turn the cooking zone to a lower setting, return the meat to the pan and add your sauce.
6. Stir the ingredients gently to make sure they are heated through.
7. Serve immediately.

Heat Settings

Heat setting	Suitability
1 - 2	<ul style="list-style-type: none">• delicate warming for small amounts of food• melting chocolate, butter, and foods that burn quickly• gentle simmering• slow warming
3 - 4	<ul style="list-style-type: none">• reheating• rapid simmering• cooking rice
5 - 6	<ul style="list-style-type: none">• pancakes
7 - 8	<ul style="list-style-type: none">• sauteing• cooking pasta
9	<ul style="list-style-type: none">• stir-frying• searing• bringing soup to the boil• boiling water

Care and Cleaning

IMPORTANT!: For your safety, switch the power to the cooktop off at the wall before any cleaning. In this case, there will be no 'Hot surface' indication, but the cooking zones may still be hot! Take extreme care.

What?	How?	Important!
<p>Everyday soiling on glass (fingerprints, marks, stains left by food or non-sugary spillovers on the glass)</p>	<ol style="list-style-type: none"> 1. Switch the power to the cooktop off. 2. Apply a cooktop cleaner while the glass is still warm (but not hot!) 3. Rinse and wipe dry with a clean cloth or paper towel. 4. Switch the power to the cooktop back on. 	<ul style="list-style-type: none"> • When the power to the cooktop is switched off, there will be no 'hot surface' indication but the cooking zone may still be hot! Take extreme care. • Heavy-duty scourers, some nylon scourers and harsh/abrasive cleaning agents may scratch the glass. Always read the label to check if your cleaner or scourer is suitable. • Never leave cleaning residue on the cooktop: the glass may become stained.
<p>Boilovers, melts, and hot sugary spills on the glass</p>	<p>Remove these immediately with a fish slice, palette knife or razor blade scraper suitable for ceramic glass cooktops, but beware of hot cooking zone surfaces:</p> <ol style="list-style-type: none"> 1. Switch the power to the cooktop off at the wall. 2. Hold the blade or utensil at a 30° angle and scrape the soiling or spill to a cool area of the cooktop. 3. Clean the soiling or spill up with a dish cloth or paper towel. 4. Follow steps 2 to 4 for 'Everyday soiling on glass' above. 	<ul style="list-style-type: none"> • Remove stains left by melts and sugary food or spillovers as soon as possible. If left to cool on the glass, they may be difficult to remove or even permanently damage the glass surface. • Cut hazard: when the safety cover is retracted, the blade in a scraper is razor-sharp. Use with extreme care and always store safely and out of reach of children.
<p>Spillovers on the touch controls</p>	<ol style="list-style-type: none"> 1. Switch the power to the cooktop off. 2. Soak up the spill 3. Wipe the touch control area with a clean damp sponge or cloth. 4. Wipe the area completely dry with a paper towel. 5. Switch the power to the cooktop back on. 	<ul style="list-style-type: none"> • The cooktop may beep and turn itself off, and the touch controls may not function while there is liquid on them. Make sure you wipe the touch control area dry before turning the cooktop back on.

Trouble Shooting

Problem	Possible causes	What to do
The cooktop cannot be turned on.	No power.	Make sure the cooktop is connected to the power supply and that it is switched on. Check whether there is a power outage in your home or area. If you've checked everything and the problem persists, call a qualified technician.
The touch controls are unresponsive.	The controls are locked.	Unlock the controls. See section 'Using your ceramic cooktop' for instructions.
The touch controls are difficult to operate.	There may be a slight film of water over the controls or you may be using the tip of your finger when touching the controls.	Make sure the touch control area is dry and use the ball of your finger when touching the controls.
The glass is being scratched.	Rough-edged cookware. Unsuitable, abrasive scourer or cleaning products being used.	Use cookware with flat and smooth bases. See 'Choosing the right cookware'. See 'Care and cleaning'.
Some pans make crackling or clicking noises.	This may be caused by the construction of your cookware (layers of different metals vibrating differently).	This is normal for cookware and does not indicate a fault.
Cooking zones seem to turn themselves off and on during use	They cycle off and on to maintain the selected setting or prevent the glass from overheating.	This is normal and needs no action

Technical Specification

Cooking Hob	HCE302TB3
Cooking Zones	2 Zones
Supply Voltage & Frequency	220-240V~ ,50-60 Hz
Power Rating	2745-3267W
Product Size W×D×H(mm)	288X520X52
Cut out Dimensions W×D(mm)	268 ⁺⁵ X500 ⁺⁵

Cooking Hob	HCE604TB3
Cooking Zones	4 Zones
Supply Voltage & Frequency	220-240V~ or 380-415V~,50-60Hz,
Power Rating	5490- 6533W
Product Size W×D×H(mm)	590X520X52
Cut out Dimensions W×D(mm)	560 ⁺⁵ X490 ⁺⁵

Cooking Hob	HCE905TB3
Cooking Zones	5 Zones
Supply Voltage & Frequency	220-240V~ or 380-415V~,50-60Hz,
Power Rating	7502-8929W
Product Size W×D×H(mm)	900X520X52
Cut out Dimensions W×D(mm)	870 ⁺⁵ X490 ⁺⁵

Weight and Dimensions are approximate. Because we continually strive to improve our products we may change specifications and designs without prior notice.

Manufacturer's Warranty

Please read this warranty card carefully. Attach your purchase receipt to this warranty card and keep in a safe place. You must produce both warranty card and proof of purchase in the event of a warranty repair being required.

When you purchase any new Haier Product you automatically receive a two year Manufacturer's Warranty covering parts and labour for servicing.

The Manufacturer undertakes to:

Repair or, at its option, replace without cost to the owner either for material or labour any part of the Product, the serial number of which appears on the Product, which is found to be defective within TWO YEARS from the date of purchase.

This warranty DOES NOT cover:

- A** Service calls which are not related to any defect in the Product. The cost of a service call will be charged if the problem is not found to be a Product related fault. For example:
1. Correct the installation of the product.
 2. Provide Instruction on use of the product or change the setup of the product.
 3. Replace house fuses or correct house wiring.
 4. Correcting fault(s) caused by the user.
 5. Noise or vibration that is considered normal.
 6. Water on the floor due to incorrect loading or excessive suds.
 7. Blocked pumps, removal of foreign objects/substances from the machine, including the pump and inlet house filters.
 8. Correcting damage caused by pests, eg. rats, cockroaches etc.
 9. Correct corrosion or discolouration due to chemical attack.
 10. Power outages or surges.
- B** Defects caused by factors other than:
1. Normal domestic use or
 2. Use in accordance with the Product's User Guide.
- C** Defects to the Product caused by accident, neglect, misuse or 'Act of God'.
- D** The cost of repairs carried out by non-authorized repairers or the cost of

correcting such unauthorised repairs.

- E** Normal recommended maintenance as set out in the Product's User Guide.
- F** Repairs when the appliance has been dismantled, repaired or serviced by other than an AUTHORISED CUSTOMER SERVICE CENTRE or the selling dealer.
- G** Pick up and delivery.
- H** Transportation or travelling costs involved in the repair when the product is installed outside the AUTHORISED CUSTOMER SERVICE CENTRE'S normal service area.

This product has been designed for use in a normal domestic environment. It is not intended for commercial use. Doing so may affect product warranty. Service under this warranty must be provided by an Authorised Service Repairer (refer to the Customer Care section for contact details). Such service shall be provided during normal business hours. This warranty certificate should be shown when making any claim.

Note:

This Warranty is an extra benefit and does not affect your legal rights and applies only to product purchased in New Zealand and Australia. Please keep this Warranty Card in a safe place.

For Australian customers:

Our goods come with guarantees that cannot be excluded under the Australian Consumer Law. You are entitled to a replacement or refund for a major failure and for compensation for any other reasonably foreseeable loss or damage. You are also entitled to have the goods repaired or replaced if the goods fail to be of acceptable quality and the failure does not amount to a major failure.

Customer Care

Check the things you can do yourself.
Refer to your User Guide and check:

- 1 Your appliance is correctly installed.
- 2 You are familiar with its normal operation.
- 3 You have read the problem solving section in your User Guide.

If after checking these points you still need assistance, please refer to your nearest Haier Authorised Repairer.

In New Zealand, if you need assistance...*

Call your retailer who is trained to provide information on your appliance, or if we can be of any further help, please contact our Customer Care Centre:

Toll Free: 0800 372 273 Fax: (09) 273 0656

Email: customer.care@haier.co.nz

Postal address: P.O. Box 58732, Botany, Manukau 2163

If you need service...*

We have a network of independent Fisher & Paykel Authorised Repairers whose fully trained technicians can carry out any service necessary on your appliance. Your dealer or our Customer Care Centre can recommend a Fisher & Paykel Authorised Repairer in your area.

In Australia, if you need assistance...*

Call the Customer Care Centre and talk to one of our Customer Care Consultants.

Toll Free: 1300 729 948 Fax: (07) 3826 9298

Email: customer.care@haierlife.com.au

Postal Address: PO Box 798, Cleveland QLD 4163

If you need service...*

We have a network of qualified Authorised Repairers whose fully trained technicians can carry out any service necessary on your appliance. Our Customer Care Centre can recommend an Authorised Repairer in your area.

*If you call or write, please provide: name, address, model number, serial number, date of purchase and a description of the problem. This information is needed in

order to better respond to your request for assistance.

Product Details

Model -----Serial No. -----

Date of Purchase-----Purchaser-----

Dealer-----Suburb-----

Town-----Country-----

Thank you for choosing Haier. We are confident that you will enjoy many years of good service from your appliance.

Code:

Edition:

Publication Date: April 6, 2021