

Sunbeam

COMPACT CAFÉ GRILL GR8210
2 SLICE SANDWICH PRESS

User Guide



Contents

Sunbeam's Safety Precautions	1
Features of your Sunbeam Compact Café Grill	2
Using your Sunbeam Compact Café Grill	4
Hints for Best Results	5
Care and Cleaning	6
Recipes	7

Important instructions – retain for future use.

تأكد من تفهم احتياطات السلامة المذكورة اعلاه

請務必理解上述的安全預防措施。

Assurez-vous que les précautions ci-dessus relatives à la sécurité sont bien comprises

Versichern Sie sich, dass die obenstehenden Sicherheitsmaßnahmen Verstanden werden

Βεβαιώσετε πως οι παραπάνω προφυλάξεις ασφαλείας γίνονται κατανοητές

Pastikan bahwa tindakan-tindakan keselamatan seperti di atas dimengerti anda

Accertatevi che le suddette norme di sicurezza siano comprese a dovere

上記の注意事項をよくお読みになり、安全を御確認ください

Уверете се дека погоре споменатите мерки на претпазливост се добро разбрани

Asegúrese de que las precauciones de seguridad precedentes sean bien comprendidas

کاری بکنید کہ احتیاطهای بالا حتماً درک بشوند

ต้องแน่ใจว่า ข้อควรระวังเรื่องความปลอดภัยข้างต้น เป็นที่เข้าใจกันดี

Yukarda belirtilen güvenlik önlemlerinin anlaşıldığından emin olunuz

Xin kiểm chắc rằng những biện pháp làm an toàn kể trên được hiểu rõ

Sunbeam's Safety Precautions

SAFETY PRECAUTIONS FOR YOUR SUNBEAM SANDWICH PRESS.

- Use well away from walls and curtains.
- Avoid using on metal surfaces e.g. sink.
- Do not use in confined spaces.
- Do not immerse the unit in water.
- Ensure that the cord is kept well away from the cooking plates during use.
- Do not touch the outside or the top of the

press when in use, as these surfaces may be hot.

- Ensure you use the handle to open the top press plate. Avoid touching hot surfaces.
- This press may generate steam from between the grill plates while cooking and when the top plate is opened.
- Take care when removing food from the press.
- The temperature of accessible surfaces may be high when the appliance is operating.

Sunbeam is very safety conscious when designing and manufacturing consumer products, but it is essential that the product user also exercise care when using an electrical appliance. Listed below are precautions which are essential for the safe use of an electrical appliance:

- Read carefully and save all the instructions provided with an appliance.
- Always turn the power off at the power outlet before you insert or remove a plug. Remove by grasping the plug - do not pull on the cord.
- Turn the power off and remove the plug when the appliance is not in use and before cleaning.
- Do not use your appliance with an extension cord unless this cord has been checked and tested by a qualified technician or service person.
- Always use your appliance from a power outlet of the voltage (A.C. only) marked on the appliance.
- This appliance is not intended for use by persons (including children) with reduced physical, sensory or mental capabilities, or lack of experience and knowledge, unless they have been given supervision or instruction concerning use of the appliance by a person responsible for their safety.
- Children should be supervised to ensure that they do not play with the appliance.
- The temperature of accessible surfaces may be high when the appliance is operating.
- Never leave an appliance unattended while in use.

- Do not use an appliance for any purpose other than its intended use.
- Do not place an appliance on or near a hot gas flame, electric element or on a heated oven.
- Do not place on top of any other appliance.
- Do not let the power cord of an appliance hang over the edge of a table or bench top or touch any hot surface.
- Do not operate any electrical appliance with a damaged cord or after the appliance has been damaged in any manner. If damage is suspected, return the appliance to the nearest Sunbeam Appointed Service Centre for examination, repair or adjustment.
- For additional protection, Sunbeam recommend the use of a residual current device (RCD) with a tripping current not exceeding 30mA in the electrical circuit supplying power to your appliances.
- Do not immerse the appliance in water or any other liquid unless recommended.
- Appliances are not intended to be operated by means of an external timer or separate remote control system.
- This appliance is intended to be used in household and similar applications such as: staff kitchen areas in shops, offices and other working environments; farm houses; by clients in hotels, motels and other residential type environments; bed and breakfast type environments.

If you have any concerns regarding the performance and use of your appliance, please visit www.sunbeam.com.au or contact the Sunbeam Consumer Service Line. Ensure the above safety precautions are understood.

Features of your Sunbeam Compact Café Grill

Café-style floating hinge

The café-style floating hinge system adjusts automatically to perfectly toast any size snacks from toasted bread to Turkish or focaccia.

Die-cast metal arms

EasyClean™ non-stick cooking surface

Enables fat-free cooking and easy wipe down cleaning.

1800 watts

High powered with 1800 watts of commercial power for super fast heating.

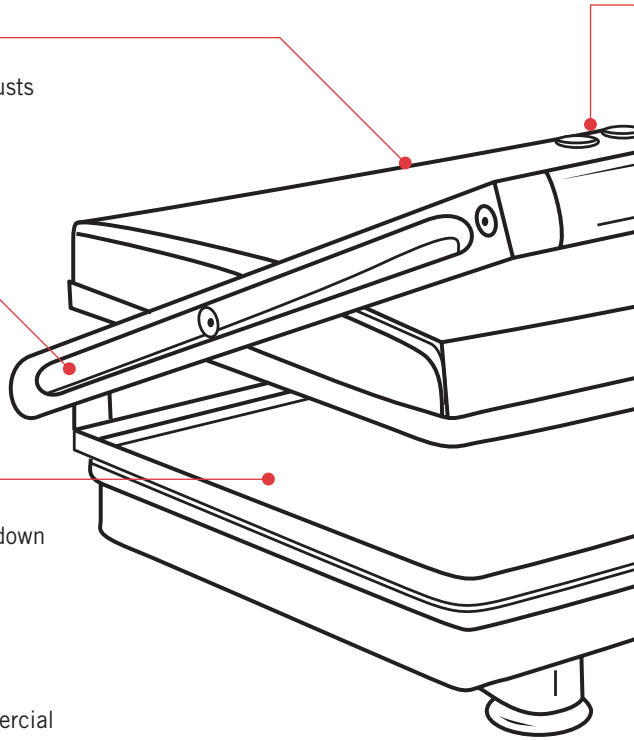

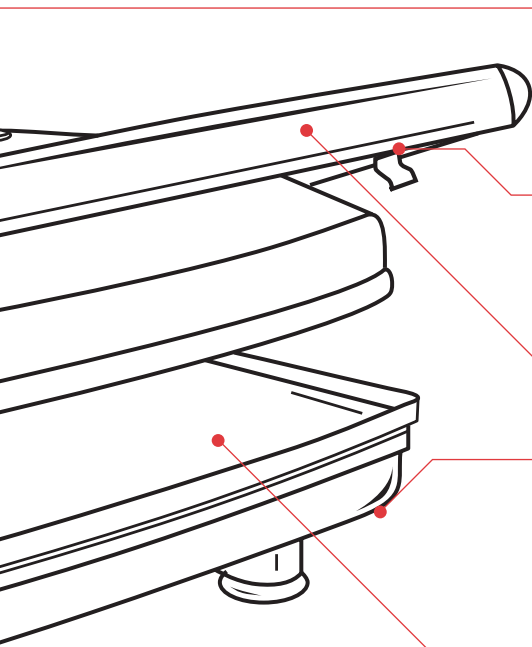

Warm up and ready lights

'Warm up' light indicates when the Café Grill is switched on and heating and the 'Ready' light indicates that it is ready to use.

Securing latch

The securing latch is located on the side of the cast metal arms and is used to lock the cooking plates together when the Café Grill is in storage.

Cool touch grip

Vertical storage with cord wrap

The cord simply wraps around the legs enabling the product to be stored conveniently in the upright position.

Non-stick grill (top) plate and flat (bottom) cooking plate

The high grade non-stick cooking plates are flat on the bottom and ribbed grill plates on the top of the Compact Café Grill.

Using your Sunbeam Compact Café Grill

Before for use

Ensure any stickers and packaging are removed from the product. Wipe over plates with a dampened cloth and dry thoroughly with a soft cloth.

Note: When using your Café Grill for the first time you may notice a fine smoke haze being emitted from the unit. This is normal. It is due to the initial heating of internal components.

Using your Café Press/Grill

1. Plug the power cord into a 230-240 volt AC power outlet.
2. Turn the power ON and pre-heat your Café Press/Grill until the Ready light illuminates.
3. Once you have prepared your snack, place the bread onto the cooking plate.

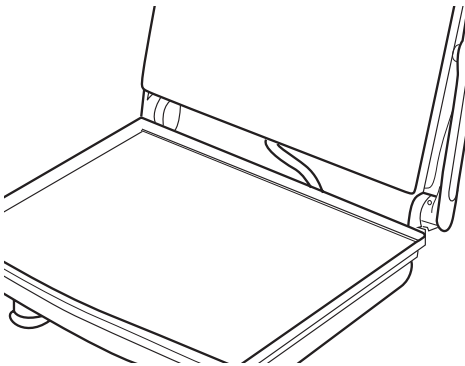

4. Gently lower the lid by pulling down the handle. The café-style floating hinge system will adjust automatically ensuring that the top cooking plate lies evenly on your snack, for perfect toasting every time.

Note: Ensure that the cord is kept well away from the cooking plates when in use.

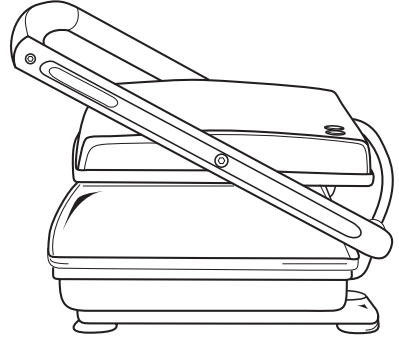

5. Allow your snack to toast for approximately 3 minutes, depending on the bread, filling and personal taste. Your Café Grill toasts both sides of bread at the same time.
6. The cooking plates are coated with a durable non-stick coating. Some fillings such as cheese may melt and cause the sandwich to stick to the cooking plates. To free the sandwich use a plastic spatula or wooden spoon. Never use a sharp or metal object, as this will damage the non-stick surface.

Note: The 'warm up' and 'ready' lights are thermostatically controlled and will cycle during cooking to ensure that the correct temperature is maintained.

7. After you have completed using your Café Grill, turn the power OFF.

Hints for best results

1. Any type or shape of bread can be used, e.g. white, wholemeal, wholegrain, sourdough, bread rolls, bagels.
2. Various thicknesses of bread can be used from thick to thin slice. Turkish pide or focaccia are also suitable.
3. Sweet breads with a high sugar content (e.g. fruit loaf, raisin bread, brioche) will brown more quickly than non-sweetened breads.
4. It is not necessary to butter the outside of your bread as the Café Grill has non-stick cooking plates.
5. Be careful when biting into snacks containing fillings such as cheese, tomato or jam as they retain heat and can burn if eaten too quickly.

Care and Cleaning

EasyClean™ Non-Stick Coating

Your Café Grill features a special non-stick coating which can be simply wiped clean with a damp cloth.

Do not use sharp objects or cut food on top of the Café Grill.

Sunbeam will not be liable for damage to the non-stick coating where metal utensils have been used.

When cleaning the non-stick coating do not use metal (or other abrasive) scourers.

After cleaning, dry the Café Grill and lid thoroughly with a soft cloth before storing.

Always turn the power OFF and REMOVE the plug from the power point before cleaning.

Quick cleaning method

Always turn the power OFF and remove plug after use and before cleaning. The cooking plates are coated with a non-stick surface, and there are no dirt traps, therefore little cleaning is required. Once cooled, simply wipe the cooking plates with a dampened cloth.

Do not immerse your Café Grill in water or any other liquid. Do not use abrasive scouring pads or powders.

Do not place your Café Grill in a dishwasher.

Always clean after each use to prevent a build up of cooking residue on the grill.

To clean the exterior

Simply wipe over with a dampened cloth and polish dry with a dry soft cloth. Do not use steel wool, scouring pads or abrasive cleaners as these will scratch the surface.

Storage

Your Café Grill will store in an upright position in cupboards, shelves or on the bench top. Simply bring the plates together and located on the right cast metal arm, press the securing latch. This will lock the plates together.

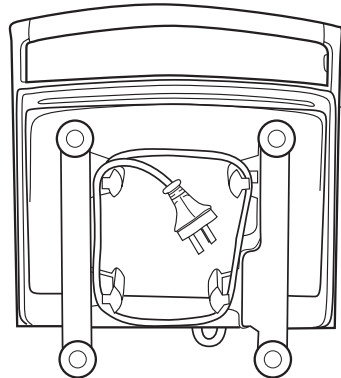

Toasted Snacks

All the recipes have been specifically created and tested by the Sunbeam Test Kitchen for the Sunbeam Café Grill. We hope you enjoy using your Sunbeam grill.

NOTE: These recipes make 2 sandwiches, to make 4 sandwiches double the quantity.

Bacon and Egg Sandwiches

2 rashers bacon, rind removed and finely chopped

1 tablespoon finely chopped shallot

2 eggs, lightly beaten

pepper and salt to taste

4 slices bread, buttered

Pre-heat your Café Press/Grill. Place 2 slices of bread, buttered side down onto the Café Press/Grill. Combine bacon, seasoning, shallot and egg mixture onto the bread. Cover with remaining bread slices and cook for approximately 4 minutes, or until golden.

Herbed Tomato Sandwiches

2 tablespoons chopped fresh basil

½ tomato, sliced

½ onion, thinly sliced

¼ cup cottage cheese

4 slices bread, buttered

Pre-heat your Café Press/Grill. Combine basil, tomato, onion and cottage cheese. Assemble sandwiches and cook for approximately 3 minutes, or until golden brown.

Golden Hawaiian Sandwiches

2 slices tasty cheese

2 rings tinned pineapple

½ cup chopped ham

4 slices bread, buttered

Pre-heat your Café Press/Grill. Place 2 slices of bread, buttered side down, onto the Café Press/Grill. Add cheese, pineapple rings and chopped ham onto bread. Cover with remaining slices of bread buttered side up. Cook for approximately 3 minutes, or until golden brown.

Chicken and Walnut Sandwiches

1 cup cooked chicken, chopped

2 tablespoons chopped walnuts

2 tablespoons chopped celery

1 tablespoon sultanas

2 tablespoons mayonnaise and

4 slices bread, buttered

Pre-heat your Café Press/Grill. Combine chicken, walnuts, celery, sultanas and mayonnaise. Divide mixture and assemble sandwiches. Cook for approximately 3 minutes or until golden brown.

Corn and Ham

1 x 310g can creamed corn

4 slices ham, finely chopped

4 slices bread, buttered

Pre-heat your Café Press/Grill. Place 2 slices of bread into the Café Press/Grill, spoon in combined creamed corn and ham strips. Assemble sandwiches and cook for 4-5 minutes, or until golden brown.

Gourmet Delights

For a toasted snack that is a little different and a real treat, substitute sliced bread with focaccia bread, Turkish bread, pita bread or bagels.

Italian Special

8 thin slices Italian salami
6 sundried tomatoes
½ cup ricotta cheese
6 capsicum rings
2 large pieces focaccia bread, halved
Pre-heat your Café Press/Grill. Assemble ingredients onto bread and place in Café Press/Grill. Cook for approximately 3 minutes, or until golden brown.

Greek Savoury

½ cup fetta cheese, crumbled
½ cup tasty cheese, grated
½ cup cooked spinach, (packed spinach is fine)
2 large pieces focaccia bread, halved
Pre-heat your Café Press/Grill. Assemble ingredients onto bread and place in Café Press/Grill. Cook for approximately 4 minutes, or until golden brown.

Gourmet Express

½ cup avocado, sliced
4 slices swiss cheese
1 tomato, sliced
4 slices leg ham
2 large pieces Turkish bread, halved
Pre-heat your Café Press/Grill. Assemble ingredients onto bread and place in Café Press/Grill. Cook for approximately 4 minutes, or until golden brown.

Bagel Combo

2 rashers bacon, grilled
Roasted red capsicum pieces
¼ cup cottage cheese
2 bagels, halved
Pre-heat your Café Press/Grill. Assemble ingredients onto bread and place in Café Press/Grill. Cook for approximately 4 minutes, or until golden brown.

Salmon Hat

¼ cup cream cheese
4 slices smoked salmon
1 tablespoon capers
2 bagels, halved
Pre-heat your Café Press/Grill. Assemble ingredients onto bread and place in Café Press/Grill. Cook for approximately 4-5 minutes, or until golden brown.

12 Month Replacement Guarantee

This Sunbeam product is covered by a 12 month replacement or repair warranty, which is in addition to your rights under the Australian Consumer Law (if your product was purchased in Australia) or New Zealand Consumer Guarantees Act (if your product was purchased in New Zealand).

Upon receipt of your claim, Sunbeam will seek to resolve your difficulties or, if the product is defective, advise you on how to obtain a replacement or refund.

To assist us in managing warranty claims, we recommend you register your product as soon as practicable after purchase by creating a MySunbeam account on our website and uploading a copy of your original receipt.

In order to make a claim under our warranty, you must have the original proof of purchase documentation for the product and present it when requested (if not already uploaded to our website).

Should your product develop any defect within 12 months of purchase because of faulty materials or workmanship, we will replace or repair it, at our discretion, free of charge. A product presented for repair may be replaced by a refurbished product of the same type rather than being repaired. Refurbished parts may be used to repair the product.

Our replacement or repair warranty only applies where a defect arises as a result of faulty material or workmanship during the warranty period. Your warranty does not cover misuse or negligent handling (including damage caused by failing to use the product in accordance with this instruction booklet), accidental damage, or normal wear and tear.

Your warranty does not:

- cover freight or any other costs incurred in making a claim, consumable items, accessories that by their nature and limited lifespan require periodic renewal (such as filters and seals) or any consequential loss or damage; or
- cover damage caused by:
 - power surges, power dips, voltage supply problems, or use of the product on incorrect voltage;

- servicing or modification of the product other than by Sunbeam or an authorised Sunbeam service centre;
- use of the product with other accessories, attachments, product supplies, parts or devices that do not conform to Sunbeam specifications; or
- exposure of the product to abnormally corrosive conditions; or

- extend beyond 3 months if the product is used in commercial, industrial, educational or rental applications.

The benefits given to you by our warranty are in addition to other rights and remedies under law in relation to the product.

In Australia our goods come with guarantees that cannot be excluded under the Australian Consumer Law. You are entitled to a replacement or refund for a major failure and for compensation for any other foreseeable loss or damage. You are also entitled to have the goods repaired or replaced if the goods fail to be of acceptable quality and the failure does not amount to a major failure.

Our goods also come with guarantees that cannot be excluded under the New Zealand Consumer Guarantees Act.

If your warranty claim is not accepted, we will inform you and if requested to do so by you, repair the product provided you pay the usual charges for such repair. You will also be responsible for all freight and other costs.

Should your product require repair or service after the warranty period, contact your nearest Sunbeam service centre. For a complete list of Sunbeam's service centres, visit our website or call our customer service line for advice on 1300 881 861 in Australia, or 0800 786 232 in New Zealand.

Should you experience any difficulties with your product during the warranty period, please contact our customer service line for advice on 1300 881 861 in Australia, or 0800 786 232 in New Zealand.

Australia

www.sunbeam.com.au
1300 881 861
Units 5 & 6,
13 Lord Street,
Botany NSW 2019
Australia

New Zealand

www.sunbeam.co.nz
0800 786 232
Level 6, Building 5,
Central Park,
660-670 Great South Road,
Greenlane, Auckland
New Zealand

Need help with your appliance?

Contact our customer service team or visit our website for information and tips on getting the most from your appliance.

Australia | **visit** www.sunbeam.com.au
phone 1300 881 861
mail Units 5 & 6, 13 Lord Street,
Botany NSW 2019 Australia.

New Zealand | **visit** www.sunbeam.co.nz
phone 0800 786 232
mail Level 6, Building 5,
Central Park,
660-670 Great South Road,
Greenlane, Auckland.

Sunbeam Corporation Limited | ABN 45 000 006 771
Sunbeam Corporation is a division of GUD Holdings Limited.

Sunbeam is a registered trade mark.

'EasyClean' is a trade mark of Sunbeam Corporation.

'Compact Cafe Grill' is a registered trade mark of Sunbeam Corporation.

Made in China to Sunbeam's specification.

Due to minor changes in design or otherwise,
the product you buy may differ slightly from the one shown here.

Approved by the appropriate electrical regulatory authorities.

©Sunbeam Corporation Limited 2016.