

SEARS

Model No.
919.670030

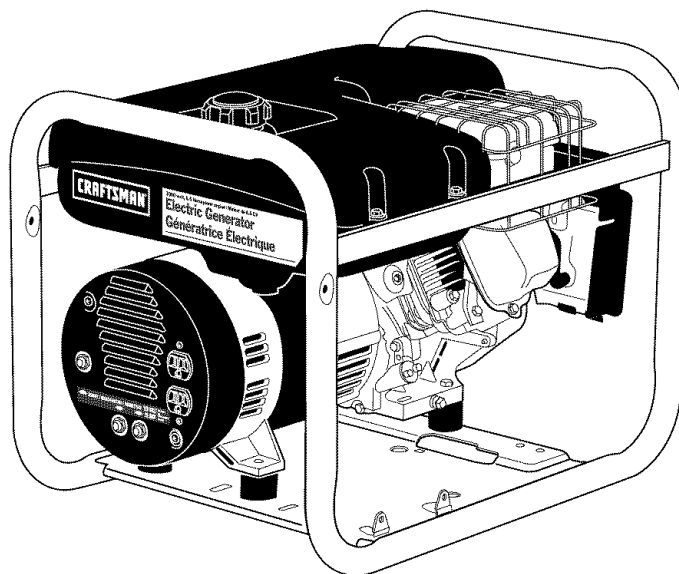

CRAFTSMAN

**120 VOLT • 3000 WATT
GENERATOR**

IMPORTANT:

Read the Safety Guidelines
and All Instructions Carefully
Before Operating

- SAFETY GUIDELINES
- ASSEMBLY
- OPERATION
- MAINTENANCE
- TROUBLESHOOTING
- REPAIR PARTS

Sold by Sears Canada, Inc., Toronto, Ont. M5B2B8

TABLE OF CONTENTS

Warranty	2	Troubleshooting Guide	17
Safety Guidelines	3-8	Emissions Control System Warranty Statement	18
Assembly	9	Generator Parts	19-23
Operation	10-13	Engine Parts	24-27
Maintenance	14-16	How To Order Parts	Back Cover
Service Adjustments	16		
Storage	17		

DATE PURCHASED: _____

MODEL NO: _____

SERIAL NO: _____

STORE WHERE PURCHASED: _____

ADDRESS: _____

CITY: _____

TELEPHONE: _____

Record the above information about your unit so that you will be able to provide it in case of loss or theft.

HORSEPOWER	6.5
GASOLINE CAPACITY	4 GALLONS/15.1 LITERS
OIL CAPACITY	20 OZ/0.6LITERS

MAINTENANCE AGREEMENT

The Craftsman Warranty, plus a Maintenance Agreement, provide maximum value for your Sears products. Contact your nearest Sears store for details.

CUSTOMER RESPONSIBILITIES

Read and observe the safety rules.

Follow a regular schedule in maintaining, caring for and using your generator.

Follow the instructions under "Customer Responsibilities" and "Storage" sections of this owner's manual.

FULL ONE YEAR WARRANTY ON CRAFTSMAN GENERATORS

For one year from the date of purchase, when this Craftsman generator is maintained and operated according to the instructions in this owner's manual, Sears will repair, free of charge, any defect in material and workmanship.

If your Craftsman Generator is used for commercial or rental purposes, this warranty applies for only 90 days from the original date of purchase.

FULL ONE YEAR WARRANTY ON CRAFTSMAN ENGINE

For one year from the date of purchase, when this Craftsman engine is maintained and operated according to the instructions in this owner's manual, Sears will repair, free of charge, any defect in material and workmanship.

If your Craftsman engine is used for commercial or rental purposes, this warranty applies only for 90 days from the date of purchase. This warranty does not cover: Expendable items such as spark plugs and air filters, which become worn during normal use.

Repairs necessary because of operator abuse or negligence, including damage resulting from no oil being supplied to the engine or failure to maintain the equipment according to the instructions contained in this owner's manual, are not covered under warranty.

WARRANTY SERVICE IS AVAILABLE BY RETURNING THE GENERATOR TO THE NEAREST SEARS SERVICE CENTER. This warranty gives you specific legal rights and you may also have other rights, which vary from PROVINCE TO PROVINCE.

Sold by Sears Canada, Inc., Toronto, Ont.



SAFETY GUIDELINES - DEFINITIONS

This manual contains information that is important for you to know and understand. This information relates to protecting **YOUR SAFETY** and **PREVENTING EQUIPMENT PROBLEMS**. To help you recognize this information, we use the symbols to the right. Please read the manual and pay attention to these sections.

⚠ DANGER	⚠ CAUTION
DANGER indicates an imminently hazardous situation which, if not avoided, will result in death or serious injury .	CAUTION indicates a potentially hazardous situation which, if not avoided, may result in minor or moderate injury .
⚠ WARNING	CAUTION
WARNING indicates a potentially hazardous situation which, if not avoided, could result in death of serious injury .	CAUTION used without the safety alert symbol indicates a potentially hazardous situation which, if not avoided, may result in property damage .

This product is not equipped with a spark arresting muffler. If the product will be used around flammable materials, or on land covered with materials such as agricultural crops, forest, brush, grass, or other similar items, then an approved spark arrester must be installed and is legally required in the state of California. It is a violation of California statutes section 130050 and/or sections 4442 and 4443 of the California Public Resources Code, unless the engine is equipped with a spark arrester, as defined in section 4442, and maintained in effective working order. Spark arresters are also required on some U. S. Forest service land and may also be legally required under other statutes and ordinances.

⚠ WARNING This product may contain chemicals known to the state of California to cause cancer, birth defects, or other reproductive harm. This warning is given in compliance with California Proposition 65, as detectable amounts of chemicals subject to proposition 65 may be contained in this product.

IMPORTANT SAFETY INSTRUCTIONS

- **SAVE THESE INSTRUCTIONS** •

⚠ WARNING

When using this product basic precautions should always be followed including the following:

⚠ DANGER

RISK OF ELECTROCUTION AND FIRE

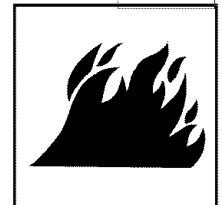
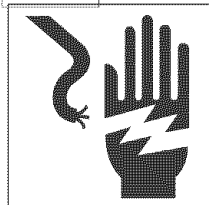

HAZARD	WHAT COULD HAPPEN	HOW TO PREVENT IT
Attempting to connect generator directly to the electrical system of any building structure.	<p>Back feeding electricity through a building's electrical system to the outside utility feed lines could endanger repair persons attempting to restore service.</p> <p>Attempting to connect to the incoming utility service could result in electrocution.</p> <p>Restoration of electrical service while the generator is connected to the incoming utility could result in a fire or serious damage if a isolator switch is not installed.</p> <p>Failure to use a double throw transfer switch when connecting to a structures electrical system can damage appliances and WILL VOID the manufacturers warranty.</p>	<p>Never backfeed electricity through a structure's electrical system.</p> <p>To connect to a structure's electrical system in a safe manner, always have a Double-Throw Transfer Switch installed by a qualified electrician and in compliance with local ordinances. (When installing a Double-Throw Transfer Switch, a minimum of 10 gauge wiring must be used.)</p>

**READ AND UNDERSTAND ALL WARNINGS BEFORE
ATTEMPTING TO OPERATE GENERATOR.**



RISK OF ELECTROCUTION AND FIRE (cont'd)

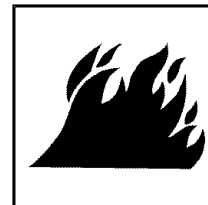
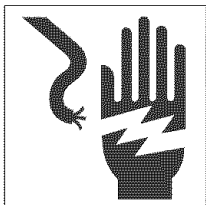

HAZARD	WHAT COULD HAPPEN	HOW TO PREVENT IT
<p>Operation of generator in rain, wet, icy, or flooded conditions.</p>	<p>Water is an excellent conductor of electricity! Water which comes in contact with electrically charged components can transmit electricity to the frame and other surfaces, resulting in electrical shock to anyone contacting them.</p>	<p>Operate generator in a clean, dry, well ventilated area. Make sure hands are dry before touching unit.</p>
<p>Use of worn damaged, undersized or ungrounded extension cords.</p>	<p>Contact with worn or damaged extension cords could result in electrocution.</p> <p>Use of undersize extension cords could result in overheating of the wires or attached items, resulting in fire.</p> <p>Use of ungrounded cordsets could prevent operation of circuit breakers and result in electrical shock.</p>	<p>Inspect extension cords before use and replace with new cord if required.</p> <p>Use proper size (wire gauge) cordset for application see chart in the Assembly section of this manual.</p> <p>Always use a cordset having a grounding wire with an appropriate grounding plug. DO NOT use an ungrounded plug.</p>
<p>Placing generator on or against highly conductive surface, such as a steel walkway or metal roof.</p>	<p>Accidental leakage of electrical current could charge conductive surfaces in contact with the generator.</p>	<p>Place generator on low conductivity surface such as a concrete slab.</p> <p>ALWAYS operate generator a minimum of six feet from any conductive surface.</p>
<p>Improper connection of items to generator.</p>	<p>Exceeding the load capacity of the generator by attaching too many items, or items with very high load ratings to it could result in overheating of some items or their attachment wiring resulting in fire or electrical shock.</p>	<p>Read the load rating chart and instructions in the Wattage Calculation section. Make sure that the summation of electrical loads for all attachments does not exceed the load rating of the generator.</p>
<p>Operation of unit when damaged, or with guards or panels removed.</p>	<p>Attempting to use the unit when it has been damaged, or when it is not functioning normally could result in fire or electrocution.</p> <p>Removal of guarding could expose electrically charged components and result in electrocution.</p>	<p>Do not operate generator with mechanical or electrical problem. Have unit repaired by an Authorized Service Center.</p> <p>Do not operate generator with protective guarding removed.</p>



**READ AND UNDERSTAND ALL WARNINGS BEFORE
ATTEMPTING TO OPERATE GENERATOR.**

**⚠ WARNING
RISK OF FIRE**

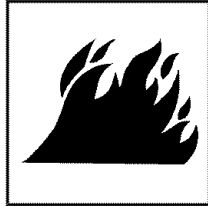

HAZARD	WHAT COULD HAPPEN	HOW TO PREVENT IT
<p>Attempting to fill the fuel tank while the engine is running.</p>	<p>Gasoline and gasoline vapors can become ignited by coming in contact with hot components such as the muffler, engine exhaust gases, or from an electrical spark.</p>	<p>Turn engine off and allow it to cool before adding fuel to the tank. Equip area of operation with a fire extinguisher certified to handle gasoline or fuel fires.</p>
<p>Sparks, fire, hot objects</p>	<p>Cigarettes, sparks, fires, or other hot objects can cause gasoline or gasoline vapors to ignite.</p>	<p>Add fuel to tank in well ventilated area. Make sure there are no sources of ignition near the generator.</p>
<p>Improper storage of fuel</p>	<p>Improperly stored fuel could lead to accidental ignition. Fuel improperly secured could get into the hands of children or other unqualified persons.</p>	<p>Store fuel in a OSHA approved container designed to hold gasoline. Store container in secure location to prevent use by others.</p>
<p>Inadequate ventilation for generator</p>	<p>Materials placed against or near the generator or operating the generator in areas where the temperature exceeds 104° F. ambient (such as storage rooms or garages) can interfere with its proper ventilation features causing overheating and possible ignition of the materials or buildings.</p>	<p>Operate generator in a clean, dry, well ventilated area a minimum of four feet from any building, object or wall. DO NOT OPERATE UNIT INDOORS OR IN ANY CONFINED AREA.</p>
<p>Tampering with factory set engine speed settings.</p>	<p>Engine speed has been factory set to provide safe operation. Tampering with the engine speed adjustment could result in overheating of attachments and could cause a fire.</p>	<p>Never attempt to “speed-up” the engine to obtain more performance. Both the output voltage and frequency will be thrown out of standard by this practice, endangering attachments and the user.</p>
<p>Overfilling the fuel tank – fuel spillage.</p>	<p>Spilled fuel and its vapors can become ignited from hot surfaces or sparks.</p>	<p>Use care in filling the tank to avoid spilling fuel. Make sure fuel cap is secured tightly and check engine for fuel leaks before starting engine. Move generator away from refueling area or any spillage before starting engine. Allow for fuel expansion. Keep maximum fuel level ¼ inch below the tip of the fuel tank. Never refuel with the engine running.</p>



READ AND UNDERSTAND ALL WARNINGS BEFORE

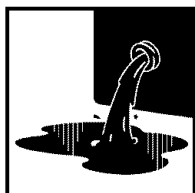

⚠ DANGER

Risk of Injury and Property Damage When Transporting Generator

HAZARD	WHAT COULD HAPPEN	HOW TO PREVENT IT
Fire, Inhalation, Damage to Vehicle Surfaces	Fuel or oil can leak or spill and could result in fire or breathing hazard, serious injury or death can result. Fuel or oil leaks will damage carpet, paint or other surfaces in vehicles or trailers.	If generator is equipped with a fuel shut-off valve, turn the valve to the off position before transporting to avoid fuel leaks. If generator is not equipped with a fuel shut-off valve, drain the fuel from tank before transporting. Transport fuel only in an OSHA approved container. Always place generator on a protective mat when transporting to protect against damage to vehicle from leaks. Remove generator from vehicle immediately upon arrival at your destination

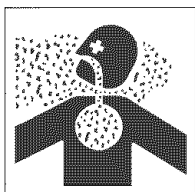

⚠ DANGER

RISK OF BREATHING - INHALATION HAZARD

HAZARD	WHAT COULD HAPPEN	HOW TO PREVENT IT
Gasoline engines produce toxic carbon monoxide exhaust fumes.	Breathing exhaust fumes will cause serious injury or death.	Operate generator in clean, dry, well ventilated area. Never operate unit in enclosed areas such as garages, basements, storage, sheds, or in any location occupied by humans or animals. Keep children, pets and others away from area of operating unit.



**READ AND UNDERSTAND ALL WARNINGS BEFORE
ATTEMPTING TO OPERATE GENERATOR.**



⚠ WARNING

RISK OF UNSAFE OPERATION

HAZARD	WHAT COULD HAPPEN	HOW TO PREVENT IT
Operation of generator in careless manner.	All sources of energy include the potential for injury. Unsafe operation or maintenance of your generator could lead to serious injury or death to you or others.	<ul style="list-style-type: none"> • Review and understand all of the operating instructions and warnings in this manual. • Become familiar with the operation and controls of the generator. Know how to shut it off quickly. • Equip area of operation with a fire extinguisher certified to handle gasoline or fuel fires. • Keep children or others away from the generator at all times.
Operation of voltage sensitive appliances without a voltage surge protector.	Any gasoline operated household generator will incur voltage variations causing damage to voltage sensitive appliances or could result in fire.	<p>Always use a U.L. listed voltage sensitive surge protector to connect voltage sensitive appliances such as TV, computer, stereo equipment. Failure to use a U.L. listed voltage surge protector will void the warranty on your generator.</p> <p>Notice: A multiple outlet strip is not a surge protector make sure you use a U.L. listed voltage surge protector.</p>
Raising or suspending generators equipped with lift rings improperly	<p>Generator could fall causing serious injury or death to you or others.</p> <p>Improper raising or suspending can cause damage to the generator.</p>	<p>Always use proper connecting procedures as described in this manual when connecting cables, chains, or straps for raising or suspending generators equipped with lift rings.</p> <p>Always use cables, chains, or straps rated at 2000 lbs working load or more to raise or suspend generator.</p>
Operating generator while suspended	Generator will not operate properly and will cause damage to the generator and could cause serious injury or death to you or others.	Never operate generator while suspended or in an unlevel position. Always operate generate on a flat, level surface.



**READ AND UNDERSTAND ALL WARNINGS BEFORE
ATTEMPTING TO OPERATE GENERATOR.**



**⚠ WARNING
RISK OF HOT SURFACES**

HAZARD	WHAT COULD HAPPEN	HOW TO PREVENT IT
Contact with hot engine and generator components.	Contact with hot surfaces, such as engines exhaust components, could result in serious burns.	During operation, touch only the control surfaces of the generator. Keep children away from the generator at all times. They may not be able to recognize the hazards of this product.

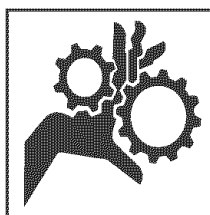

**⚠ WARNING
RISK OF MOVING PARTS**

HAZARD	WHAT COULD HAPPEN	HOW TO PREVENT IT
Contact with moving parts can result in serious injury.	The generator contains parts which rotate at high speed during operation. These parts are covered by guarding to prevent injury.	Never operate generator with guarding or cover plates removed. Avoid wearing loose fitting clothing or jewelry which could be caught by moving parts.



**⚠ WARNING
RISK FROM LIFTING**

HAZARD	WHAT COULD HAPPEN	HOW TO PREVENT IT
Lifting a very heavy object.	Serious injury can result from attempting to lift too heavy an object.	The generator is too heavy to be lifted by one person. Obtain assistance from others before you try to move it.

ASSEMBLY

CARTON CONTENTS

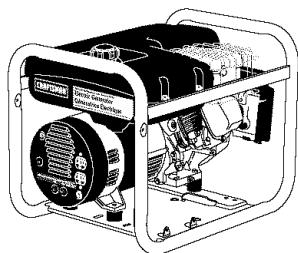

1 - Generator



1 - Owner's Manual

CAUTION

Read owner's manual. Do not attempt to operate equipment until you have read Owner's Manual for Safety, Assembly, Operation, Maintenance, and Storage Instructions.

NOTE: Left and right describes the location of a part with the operator facing the outlet panel.

TOOLS NEEDED FOR ASSEMBLY

1 - Box Cutter or Knife

REMOVE GENERATOR FROM CARTON

- Open carton from top.
- Cut carton along dotted lines.
- Remove all carton inserts.
- Remove generator through opening in carton.

IMPORTANT: Before any attempt to start your generator be sure to check engine oil (See Adding Engine Oil paragraph in the Operation section on page 12 of this manual.)

GROUNDING THE GENERATOR

A grounding lug is supplied with the generator for use when required by local electrical ordinances. Refer to article 250 of the National Electrical Code to clarify any needed grounding information. Your local electric company or a certified electrician should be able to help you with this information.

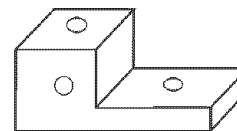

Grounding Lug

NOTE: Your engine is already grounded to the frame by a grounding strap.

OPERATION

KNOW YOUR GENERATOR

Read this Owner's Manual and Safety Rules before operation of your Generator. Compare this illustration with your generator to familiarize yourself with the location of various controls and adjustments. Save the manual for future references.

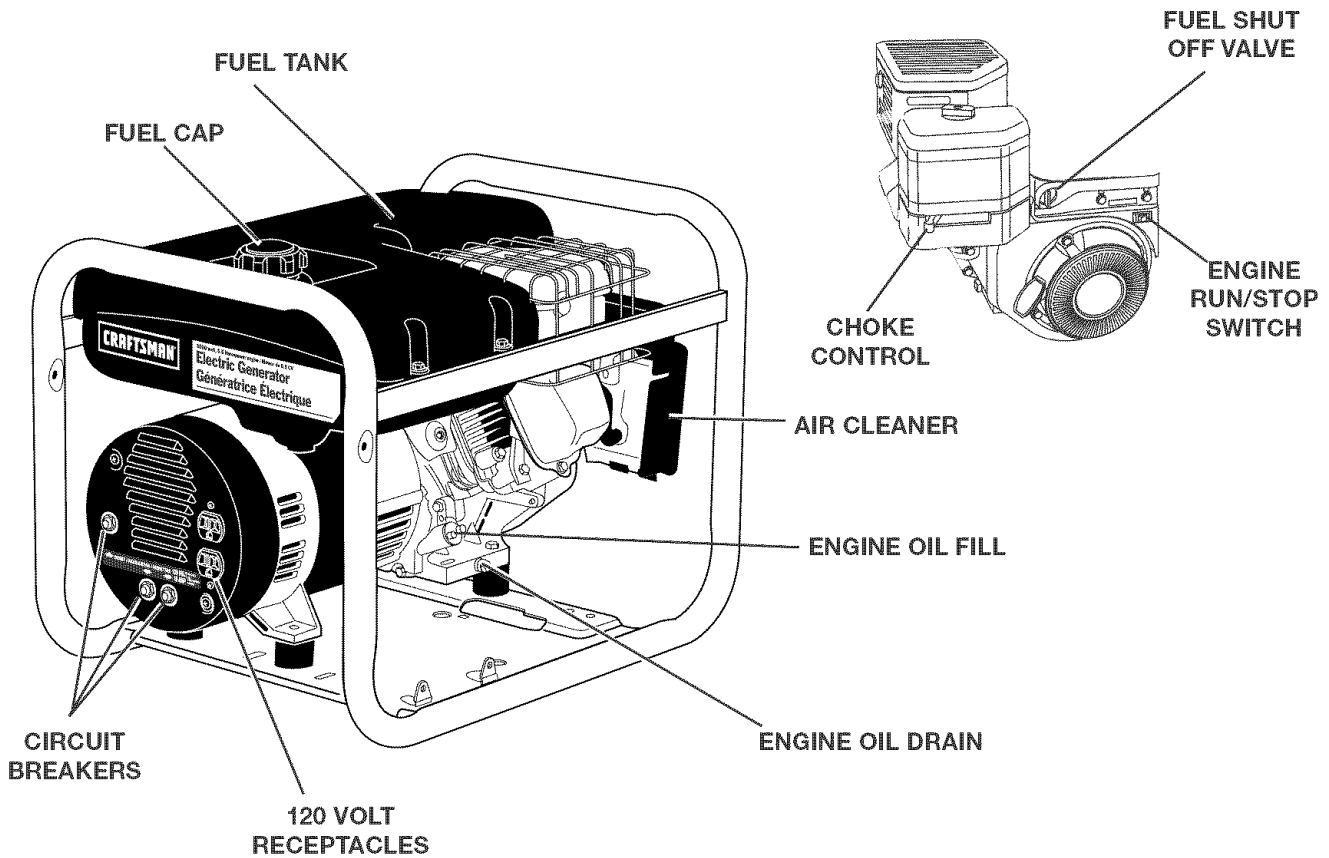

FUEL TANK- Capacity of 4 US gallons/15.1 liters.

CHOKE CONTROL- Used to start cold engine.

ENGINE ON/OFF SWITCH- Sets engine in starting mode for recoil starter - Stops running engine.

FUEL SHUT OFF VALVE (located on engine) - Used to shut off the flow of fuel to the engine.

ENGINE OIL FILL- Check and fill engine with oil.

AIR CLEANER- Includes filter element cartridge and foam pre-cleaner that limits the amount of dirt that enters the engine.

CIRCUIT BREAKER- Protects the generator from overloading.

120 VOLT RECEPTACLE- Used to supply 3000 watts of electrical power. Protected by two 15 amp circuit breakers.

RECEPTACLES

Your generator is equipped with a duplex 120 volt receptacle. The unit is also equipped with two 15 amp and one 25 amp circuit breakers to protect the unit against electrical overload. If the circuit breakers trip, unplug electrical load from receptacle. Let circuit breaker cool down and then push circuit breaker button to reset.

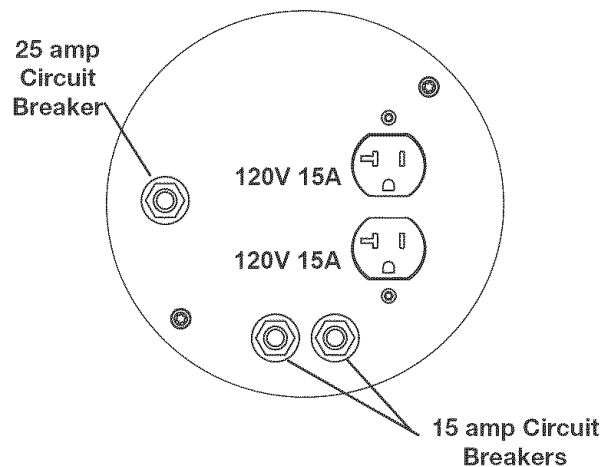

GENERATOR CAPACITY

Exceeding the rated capacity of your generator can result in serious damage to your generator and connected electrical devices. You should observe the following to prevent overloading the unit:

- Starting and running wattage requirements should always be calculated when matching a generator's wattage capacity to the appliance or tool.
- There are two types of electrical appliances that can be powered by your generator:
 - Items such as radios, light bulbs, television sets, and microwaves have a "resistive load". Starting wattage and running wattage are the same.
 - Items such as refrigerators, air compressors, washer, dryer, and hand tools that use an electrical motor have an "inductive load". Inductive load appliances and tools require approximately 2 to 4 times the listed wattage for **starting** the equipment. This initial load only lasts for a few seconds on start-up but is very important when figuring your total wattage to be used.

NOTE: Some inductive appliances and tools will list on the motor name plate, the starting and running voltage and amperage requirements. Use the following formula to convert voltage and amperage to wattage: **(Volts X Amp = Watts)**

- Always start your largest electric motor first, and then plug in other items, one at a time.

The guide is provided to assist you in determining the appliances and tools that can be ran with the wattage capacity of your generator.

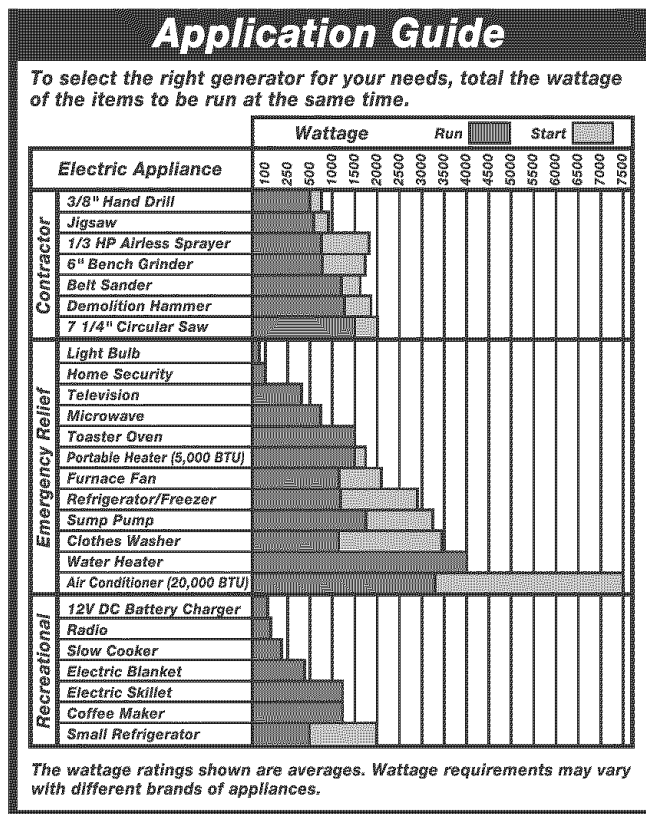

OBTAINING ELECTRICITY FROM GENERATOR

There are basically two ways to obtain electricity from a generator:

- Use of extension cords directly from the generator to the appliance, lights, tools, etc.
- Use of a double-throw transfer switch installed directly to the main electrical supply outside of the house.

Extension Cord

When using an appliance or tool at a considerable distance from the generator, a 3-wire extension cord that has a 3-blade grounding plug and 3-slot receptacle that accepts the tool's plug **MUST** be used in order to reduce the risk of electrical shock. A cord of adequate size must be used. A minimum of 12 gauge wire size with at least a 20 amp draw can be used. When amperage exceeds 20 amps a 10 gauge wire size should be used.

⚠ WARNING An extension cord that is hot to the touch is overloaded. Repair or replace damaged extension cords immediately.

Connecting Generator To Main Electrical Supply

Potential hazards exist when a electrical generator is connected to the main electrical supply coming into the house. It is at that point that the generator could feed back into the utility company's system causing possible electrocution of workers who are repairing electrical lines. To avoid back feeding of electricity into utility systems, a **double-throw transfer switch** should be installed between the generator and utility power. This device should be installed by a licensed electrician and in compliance with all local electrical codes.

NOTE: When installing a Double-Throw Transfer Switch, a minimum of 10 gauge wiring must be used.



BEFORE STARTING ENGINE

⚠ CAUTION Always check engine oil level before every start. Running engine low of oil or out of oil could result in serious damage to the engine.

Adding Engine Oil

Your generator has been shipped **without** oil in the engine. Begin by removing the oil dipstick and plug. Start pouring the oil in slowly.

The engine will hold approximately 20 ounces of oil. To check the oil, clean and replace the dipstick. Do not screw the dip stick in when checking the oil level. Next, remove the dipstick to check the level. The oil dipstick is clearly marked with lines that tell you when the engine has enough oil. **Do not fill above this point.**

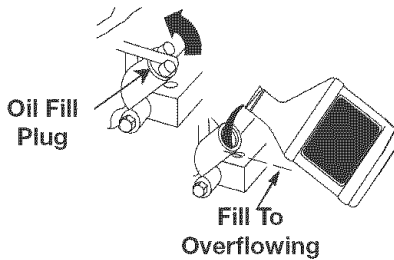

NOTE: When adding oil to the engine crankcase, use a high quality detergent oil classified "For Service SF,SG,SH" rated SAE 30 weight. Use no special additives. Select the oil's viscosity grade according to your expected operating temperatures.

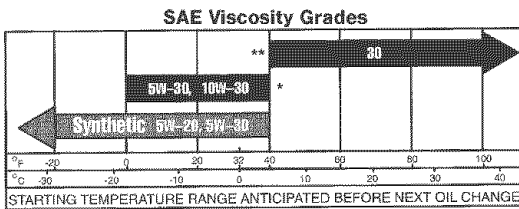

Gasoline

Your generator engine is 4 cycle. Use unleaded fuel only. Never mix oil with gasoline.

- Remove gas cap.

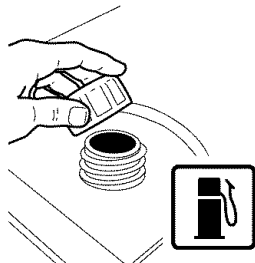

- Add unleaded gasoline, slowly, to fuel tank.

Use clean, fresh, regular unleaded gasoline with a minimum of 85 octane. Do not mix oil with gasoline.

⚠ CAUTION Never fill fuel tank completely. Fill tank to 1/2" below the bottom of the filler neck to provide space for fuel expansion. Wipe any fuel spillage from engine and equipment before starting engine.

- Do not overfill.

⚠ WARNING Never fill fuel tank indoors. Never fill fuel tank when engine is running or hot. Do not smoke when filling fuel tank.

To Start Your Generator

⚠ CAUTION Never run engine indoors or in enclosed, poor ventilated areas. Engine exhaust contains carbon monoxide, an odorless and deadly gas.

- Move the choke control located on the engine to "CHOKE" position.

NOTE: No choke is required on warm engines. Make sure choke is in the "NO CHOKE" position on warm engine starts.

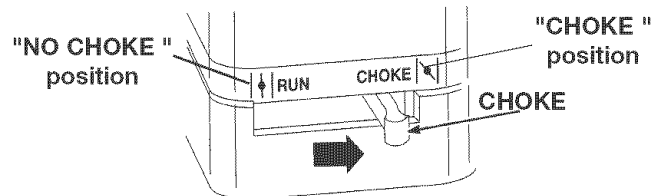

- Turn the fuel shut-off valve located on the engine to the ON position.

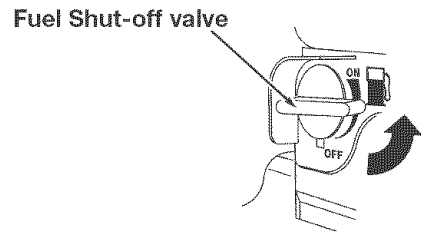

- Move ON/OFF switch located on the front panel of the engine to the "ON" position.

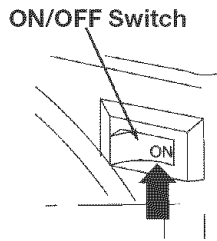

CAUTION You MUST unplug any load from the generator before starting to prevent permanent damage to any appliances.

- Grasp handle on rope starter and pull slowly until resistance is felt. Let the rope rewind slowly. Pull rope with a rapid full arm stroke. Let rope rewind slowly. Repeat if necessary.
- When engine starts, gradually move the choke to the "NO CHOKE" position.

IMPORTANT: Allow generator to run at no load for 5 minutes upon each initial start-up to allow engine and generator to stabilize.

STOPPING ENGINE

- Disconnect all electrical loads.
- Turn ON/OFF switch to "OFF" position.

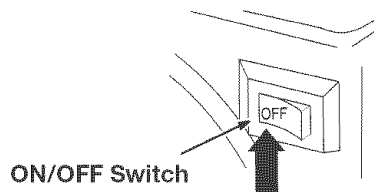

- Close fuel shut-off valve.

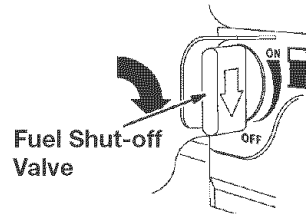

NOTE: When engine is transported, close fuel shut-off valve to prevent leakage.

IMPORTANT: Never store engine with fuel in tank, indoors, or in enclosed, poorly ventilated areas or where fuel fumes may reach an open flame.

CONNECTING ELECTRICAL LOADS

- Let engine run and warm up for five minutes after starting with no electrical load.

Connect loads in the following manner to prevent damage to equipment:

- Connect inductive load equipment first, inductive loads consist of refrigerators, freezers, water pumps, air conditioners, or small hand tools. Connect the items that require the most wattage first.
- Connect the lights next.
- Voltage sensitive equipment should be the last equipment connected to the generator. Plug voltage sensitive appliances such as TV's, VCR's, microwaves, ovens, computers, and cordless telephones into a UL listed voltage surge protector, then connect the UL listed voltage surge protector to the generator.

IMPORTANT: You should always add up the rated watts of all lights, tools and appliances you are powering at one time. This total should not exceed the rated capacity of you generator or circuit breaker rating of the receptacle supplying power.

MAINTENANCE

CUSTOMER RESPONSIBILITIES TABLE				
MAINTENANCE TASK	Every 8 Hours or Daily	Every 25 Hours of Every Season	Every 50 Hours of Every Season	Every 100 Hours of Every Season
Check oil level	X			
Change oil		See Note 1	X	
Service pre-cleaner		See Note 2		
Service Cartridge				X
Clean Muffler	X			
Spark Arrester			X	
Clean Cooling System				See Note 2
Check Spark Plug				X
Prepare Unit for Storage	Prepare unit for storage if it is to remain idle for more than 30 days.			

Note 1: Change oil after first five (5) operating hours, every 50 operating hours thereafter, and every 25 hours if operating under heavy load or high ambient temperature, and

Note 2: Clean more often under dusty conditions.

GENERAL RECOMMENDATIONS

The warranty of the generator does not cover items that have been subjected to operator abuse or negligence. To receive full value from the warranty, operator must maintain the generator as instructed in this manual.

Some adjustments will need to be made periodically to maintain your generator.

GENERATOR MAINTENANCE

Your generator should be kept clean and dry at all times. The generator should not be stored or operated in environments that include excessive moisture, dust or any corrosive vapors. If these substances are on the generator, clean with a cloth or soft bristle brush. Do not use a garden hose or anything with water pressure to clean the generator. Water may enter the cooling air slots and could possibly damage the rotor, stator and the internal windings of the generator head.

All adjustments in the Maintenance section of this manual should be made at least once each season.

ENGINE MAINTENANCE

NOTICE: Maintenance, replacement or repair of the emission control devices and systems may be performed by any nonroad engine repair establishment or individual. However, to obtain no charge repairs under the terms and provisions of the engine manufacturers warranty statement, any service or emission control part repair or replacement must be performed by a factory authorized dealer.

Oil

- Oil level should be checked prior to each use and at least every 8 hours of operation. To check oil see **Adding Engine Oil** paragraph in the Operation section on page 12.

Changing Engine Oil

For a new engine, change oil after the first **5 operating hours**. Thereafter, change oil after every **50 hours** of operation **or every season**.

Change the oil while the engine is still warm. The oil will flow freely and carry away more impurities. Make sure the engine is level when filling, checking, or changing oil.

Change the oil as follows:

- To keep dirt, grass clippings, etc. out of the engine, clean the area around the drain plug and dipstick before removing it.
- Remove the oil drain plug and oil fill plug. Tilt the engine slightly towards the oil drain to obtain better drainage. Be sure to allow ample time for complete drainage.

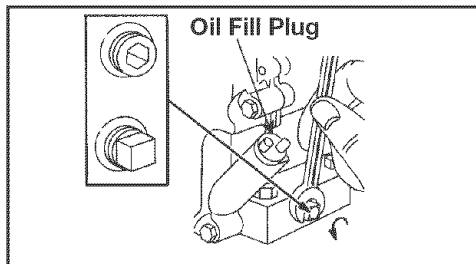

- Reinstall the drain plug. Tighten securely.
- Fill the crankcase with new oil of the proper type (See Adding Engine Oil in the Operation Section), oil capacity is 20 oz/.6 liters.

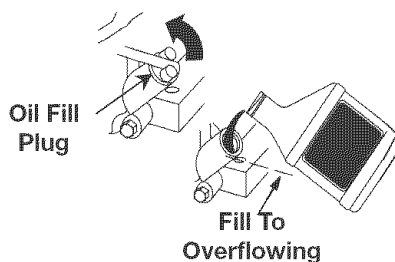

- Reinstall the oil fill plug and tighten securely.

Service Air Cleaner

NOTE: Do not use petroleum solvents, e.g., kerosene, which will cause the cartridge to deteriorate. Do not use pressurized air to clean cartridge. Pressurized air can damage the cartridge.

To service air cleaner follow these steps:

- Loosen screw and tilt cover down.
- Remove pre-cleaner and cartridge assembly from cover.

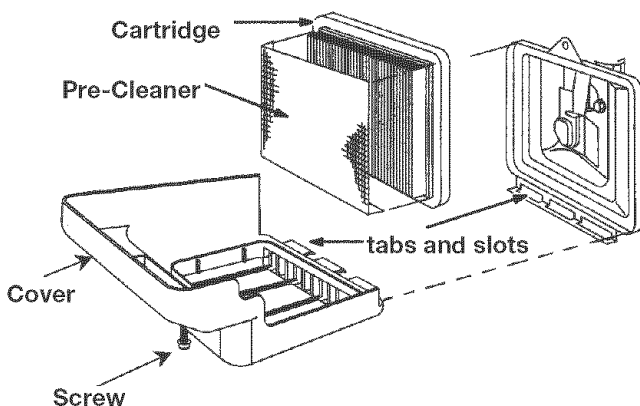

- To service pre-cleaner, wash in liquid detergent and water. Squeeze dry in a clean cloth and allow to dry thoroughly. DO NOT oil pre-cleaner.
- To service cartridge, clean by tapping gently on a flat surface. Do not oil cartridge. Replace if dirty or damaged.
- After servicing place pre-cleaner (arrows up) over cartridge pleats (pre-cleaner lip will be at bottom of pleats). Place into cover.
- Insert tabs on cover into slots in bottom of base.
- Tilt cover up and fasten securely with screw.

Clean Engine

Periodically remove debris buildup from engine. Do not clean with a forceful spray of water because water could contaminate fuel system. Clean with brush or compressed air.

CAUTION Daily or more often, before running engine, clean muffler area to remove all combustible debris.

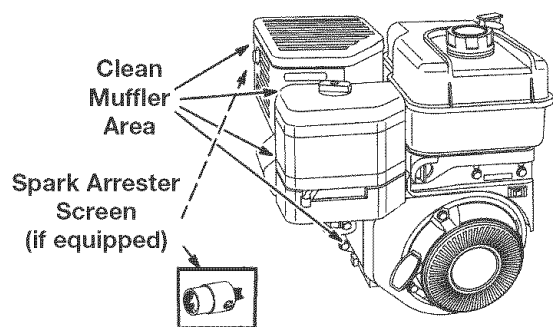

Remove spark arrestor screen for cleaning and inspection every 50 hours or every season. Replace if damaged.

In-line Filter

Replace in-line fuel filter.

CAUTION Drain fuel tank or close both fuel shut-off valve before replacing fuel filter.

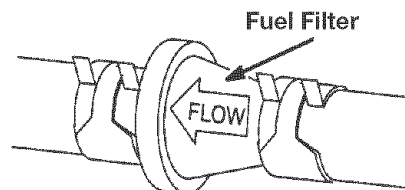

Clean Cooling System

Debris may clog engine's air cooling system, especially after prolonged operation. Internal cooling fins and surfaces may require cleaning to prevent overheating and engine damage. Remove blower housing and clean.

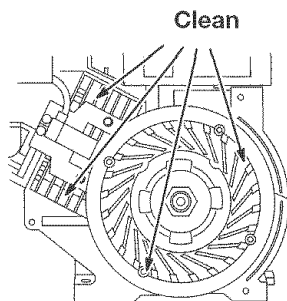

Clean and Replace Spark Plug

Check spark plug yearly or every 100 operating hours or every season.

- Clean area around spark plug.
- Remove and inspect spark plug.
- Replace spark plug if electrodes are pitted, burned or porcelain is cracked.
- Check electrode gap with wire feeler gauge and set gap .030/.76mm if necessary.
- Install spark, tighten securely.

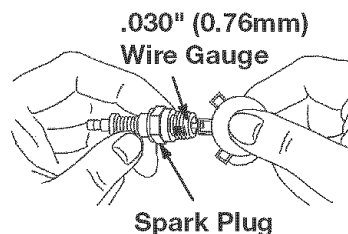

SERVICE ADJUSTMENTS

CARBURETOR

The carburetor of your generator is pre-set at the factory. The carburetor should not be tampered with. If your generator is used at an altitude in excess of 4000 feet performance may be affected. If so consult with your nearest Craftsman Service Center regarding high altitude set changes.

GOVERNOR

Your engine governor maintains the constant operating speed of your generator. **DO NOT** tamper with the engine governor which is factory set for proper engine speed.

Over-speeding your engine above factory high speed setting can be dangerous and could possibly cause personal injury or property damage. If you believe the engine is running too fast or slow, take your generator to a Authorized Craftsman Service Center for repair and adjustment.

⚠ CAUTION Low engine speeds impose a heavy load on the engine and when sufficient power is not available the engine life could be shortened.

STORAGE

If you are going to store your generator for more than 30 days, use the following information as a guide to prepare the generator for storage.

CAUTION Never store generator with fuel in the tank indoors or in enclosed, poorly ventilated areas, where fumes can reach an open flame, spark or pilot light as on a furnace, water heater, clothes dryer or other gas appliances.

Engine Preparation

- Add fuel stabilizer to fuel tank to minimize the formation of fuel gum deposits during storage.
- Run engine at least 10 minutes after adding stabilizer to allow it to enter the fuel system.

- Disconnect the spark plug wire and remove the spark plug.
- Add one teaspoon of oil through the spark plug hole.
- Place rag over spark plug hole and pull the recoil a few times to lubricate the combustion chamber. Replace the spark plug, but do not connect the spark plug wire.

NOTE: If a fuel stabilizer is not used, all gasoline must be drained from the tank and carburetor to prevent gum deposits from forming on these parts and causing possible malfunction of the engine.

Generator

- Clean the generator as outlined in the Generator Maintenance paragraph on page 14.
- Check that cooling air slots and openings on generator are open and unobstructed.

TROUBLESHOOTING GUIDE

PROBLEM	CAUSE	CORRECTION
<i>Engine will not start</i>	<ol style="list-style-type: none"> 1. Low on fuel or oil. 2. Ignition switch in "Off" position. 3. Faulty spark plug. 4. Choke in wrong position. 5. Fuel shut-off valve in closed position. 6. Unit loaded during start-up. 7. Spark plug wire loose. 	<ol style="list-style-type: none"> 1. Add fuel or oil. 2. Turn to "ON" position 3. Replace spark plug. 4. Adjust choke accordingly. 5. Open fuel shut-off valve. 6. Remove load from unit. 7. Attach wire to spark plug.
<i>No electrical output</i>	<ol style="list-style-type: none"> 1. Faulty receptacle. 2. Circuit breaker kicked out. 3. Defective capacitor. 4. Faulty power cord. 	<ol style="list-style-type: none"> 1. Have Authorized Sears Service Center replace. 2. Depress and reset. 3. Have Authorized Sears Service Center replace capacitor. 4. Repair or replace cord.
<i>Repeated circuit breaker tripping</i>	<ol style="list-style-type: none"> 1. Overload 2. Faulty cords or equipment. 	<ol style="list-style-type: none"> 1. Reduce load. 2. Check for damaged, bare, or frayed wires on equipment. Replace.
<i>Generator overheating the circuit breaker depressed</i>	<ol style="list-style-type: none"> 1. Generator overloaded. 2. Insufficient ventilation. 	<ol style="list-style-type: none"> 1. Reduce load. 2. Move to adequate supply of fresh air.

Emission Control System Warranty Statement

Briggs & Stratton Corporation (B&S), the California Air Resources Board (CARB)
and the United States Environmental Protection Agency (U.S. EPA)

Emission Control System Warranty Statement (Owner's Defect Warranty Rights and Obligations)

EMISSION CONTROL WARRANTY COVERAGE IS APPLICABLE TO CERTIFIED ENGINES PURCHASED IN CALIFORNIA IN 1995 AND THEREAFTER, WHICH ARE USED IN CALIFORNIA, AND

TO CERTIFIED MODEL YEAR 1997 AND LATER ENGINES WHICH ARE PURCHASED AND USED ELSEWHERE IN THE UNITED STATES.

California and United States Emission Control Defects Warranty Statement

The California Air Resources Board (CARB), U.S. EPA and B&S are pleased to explain the Emission Control System Warranty on your model year 2000 and later small off-road engine (SORE). In California, new small off-road engines must be designed, built and equipped to meet the State's stringent anti-smog standards. Elsewhere in the United States, new non-road, spark-ignition engines certified for model year 1997 and later, must meet similar standards set forth by the U.S. EPA. B&S must warrant the emission control system on your engine for

the periods of time listed below, provided there has been no abuse, neglect or improper maintenance of your small off-road engine.

Your emission control system includes parts such as the carburetor, air cleaner, ignition system, muffler and catalytic converter. Also included may be connectors and other emission related assemblies.

Where a warrantable condition exists, B&S will repair your small off-road engine at no cost to you including diagnosis, parts and labor.

Briggs & Stratton Emission Control Defects Warranty Coverage

Small off-road engines are warranted relative to emission control parts defects for a period of two years, subject to provisions set forth

below. If any covered part on your engine is defective, the part will be repaired or replaced by B&S.

Owner's Warranty Responsibilities

As the small off-road engine owner, you are responsible for the performance of the required maintenance listed in your Operating and Maintenance Instructions. B&S recommends that you retain all your receipts covering maintenance on your small off-road engine, but B&S cannot deny warranty solely for the lack of receipts or for your failure to ensure the performance of all scheduled maintenance.

You are responsible for presenting your small off-road engine to an Authorized B&S Service Dealer as soon as a problem exists. The undisputed warranty repairs should be completed in a reasonable amount of time, not to exceed 30 days.

If you have any questions regarding your warranty rights and responsibilities, you should contact a B&S Service Representative at 1-414-259-5262.

As the small off-road engine owner, you should however be aware that B&S may deny you warranty coverage if your small off-road engine or a part has failed due to abuse, neglect, improper maintenance or unapproved modifications.

The emission warranty is a defects warranty. Defects are judged on normal engine performance. The warranty is not related to an in-use emission test.

Briggs & Stratton Emission Control Defects Warranty Provisions

The following are specific provisions relative to your Emission Control Defects Warranty Coverage. It is in addition to the B&S engine warranty for non-regulated engines found in the Operating and Maintenance Instructions.

1. Warranted Parts

Coverage under this warranty extends only to the parts listed below (the emission control systems parts) to the extent these parts were present on the engine purchased.

a. Fuel Metering System

- Cold start enrichment system
- Carburetor and internal parts
- Fuel Pump

b. Air Induction System

- Air cleaner
- Intake manifold

c. Ignition System

- Spark plug(s)
- Magneto ignition system

d. Catalyst System

- Catalytic converter
- Exhaust manifold
- Air injection system or pulse valve

e. Miscellaneous Items Used in Above Systems

- Vacuum, temperature, position, time sensitive valves and switches
- Connectors and assemblies

2. Length of Coverage

B&S warrants to the initial owner and each subsequent purchaser that the Warranted Parts shall be free from defects in materials and workmanship which caused the failure of the Warranted Parts for a period of two years from the date the engine is delivered to a retail purchaser.

3. No Charge

Repair or replacement of any Warranted Part will be performed at no charge to the owner, including diagnostic labor which leads to the determination that a Warranted Part is defective, if the diagnostic work is performed at an Authorized B&S Service Dealer. For emissions warranty service contact your nearest Authorized B&S Service Dealer as listed in the "Yellow Pages" under "Engines, Gasoline," "Gasoline Engines," "Lawn Mowers," or similar category.

4. Claims and Coverage Exclusions

Warranty claims shall be filed in accordance with the provisions of the B&S Engine Warranty Policy. Warranty coverage shall be excluded for failures of Warranted Parts which are not original B&S parts or because of abuse, neglect or improper maintenance as set forth in the B&S Engine Warranty Policy. B&S is not liable to cover failures of Warranted Parts caused by the use of add-on, non-original, or modified parts.

5. Maintenance

Any Warranted Part which is not scheduled for replacement as required maintenance or which is scheduled only for regular inspection to the effect of "repair or replace as necessary" shall be warranted as to defects for the warranty period. Any Warranted Part which is scheduled for replacement as required maintenance shall be warranted as to defects only for the period of time up to the first scheduled replacement for that part. Any replacement part that is equivalent in performance and durability may be used in the performance of any maintenance or repairs. The owner is responsible for the performance of all required maintenance, as defined in the B&S Operating and Maintenance Instructions.

6. Consequential Coverage

Coverage hereunder shall extend to the failure of any engine components caused by the failure of any Warranted Part still under warranty.

GENERATOR PARTS

CRAFTSMAN 3000 GENERATOR 919.670030

GENERATOR ASSEMBLY

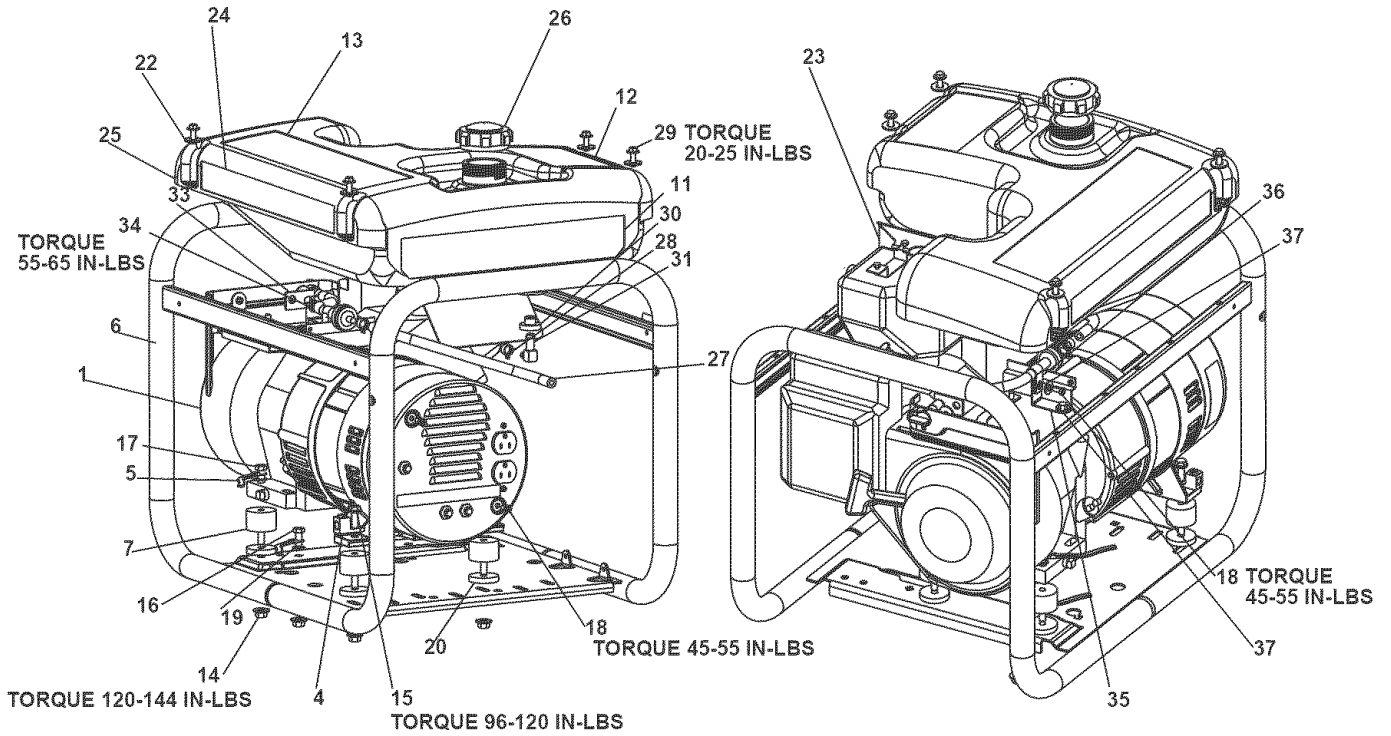

KEY NO.	DESCRIPTION	PART NUMBER
1	ENGINE	*
4	LUG GROUND	GS-0117
5	STRAP GROUND	GS-0118
6	FRAME ASSY	GS-0802
7	ISOLATOR	GS-0924
11	LABEL BILLBOARD	LA-3380
12	LABEL OPERERATION	LA-3381
13	LABEL WARNING	LA-2911
14	NUT HEX WIZ LOCK	SSF-8150
15	SCREW HEX WASHER	SSF-928
16	SCREW CAP 5/16-18 X 3/4	SS-12-CD
17	SCREW 5/16-18 X 1-1/4	SSF-605
18	SCREW 10-24 X 9/16	SSF-553-1
19	WASHER LOCK	SSN-1619-ZN
20	SPACER	GS-0925
22	WASHER	SSN-632

KEY NO.	DESCRIPTION	PART NUMBER
23	HEAT SHEILD	GS-0926
24	LABEL BILLBOARD	LA-3382
25	TANK FUEL 4 GALLON	GS-0650-1
26	CAP FUEL TANK	GS-0443
27	HOSE FUEL	GS-0225
28	CLAMP FUEL .50	GS-0227
29	SCREW 1/4 - 20 X 3/4	91895680
30	DRAIN COCK GROMMET	GS-0446
31	DRAIN COCK ELBOW	GS-0908
33	FUEL CLAMP	GS-0910
34	SCREW 1/4 x 5/8	39124607
35	BRACKET	CAC-2-1
36	CLIP, FUEL LINE	SSP-510
37	WASHER FLAT	SS-6506-CD

* SEE ENGINE PAGES



GENERATOR PARTS

CRAFTSMAN 3000 GENERATOR 919.670030

GENERATOR HEAD ASSEMBLY

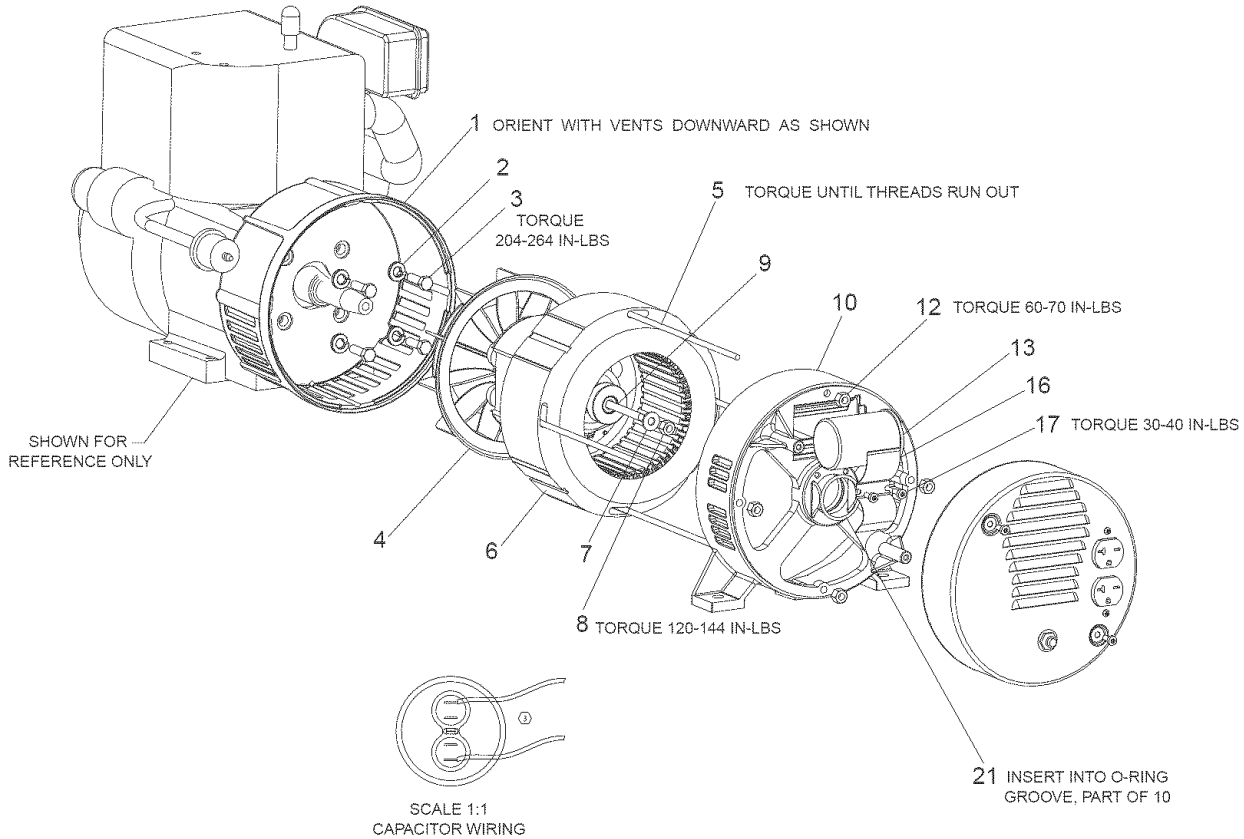

KEY NO.	DESCRIPTION	PART NUMBER
1	ADAPTER DRIVE END	GS-0558
2	WASHER LOCK	SS-1503-CD
3	SCREW HEXCAP 5/16-24 X 1	SSF-616-ZN
4	ROTOR ASSY	GS-0658
5	BOLT STATOR THRU	GS-0415
6	STATOR ASSY	GS-0898
7	WASHER FLAT 11/16 OD X 11	SS-6506-CD
8	NUT 5/16-24 HEX	SSF-576
9	BOLT ROTOR THRU	GS-0661
10	BEARING SUPPORT	GS-0861
12	NUT 1/4"-20 HEX W/KEPS	SSF-575
13	CAPACITOR	GS-0592
16	BRACKET CAPACITOR	GS-0595
17	SCREW 10-24 X 9/16	SSF-553-1
21	O-RING ROTOR BEARING	GS-0862

NOT SHOWN
DIODE GS-0082

GENERATOR PARTS

CRAFTSMAN 3000 GENERATOR 919.670030

PANEL ASSEMBLY

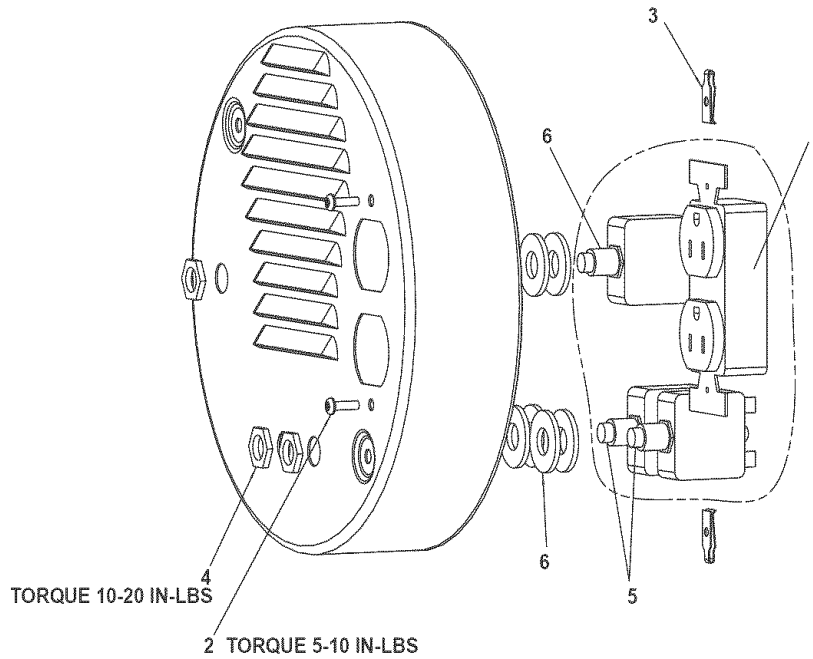

<u>KEY NO.</u>	<u>DESCRIPTION</u>	<u>PART NUMBER</u>
1	DUPLEX 120V	GS-0804
2	SCREW #6-32 x .5 TORX	SSF-583
3	NUT SPEED #6-32	SSF-584
4	NUT HEX JAM 7/16	SSF-595
5	BREAKER CIRCUIT 15 AMP	GS-0024
6	BREAKER CIRCUIT 25 AMP	GS-0645



GENERATOR PARTS

CRAFTSMAN 3000 GENERATOR 919.670030

WIRE HARNESS

ENDCOVER REAR VIEW

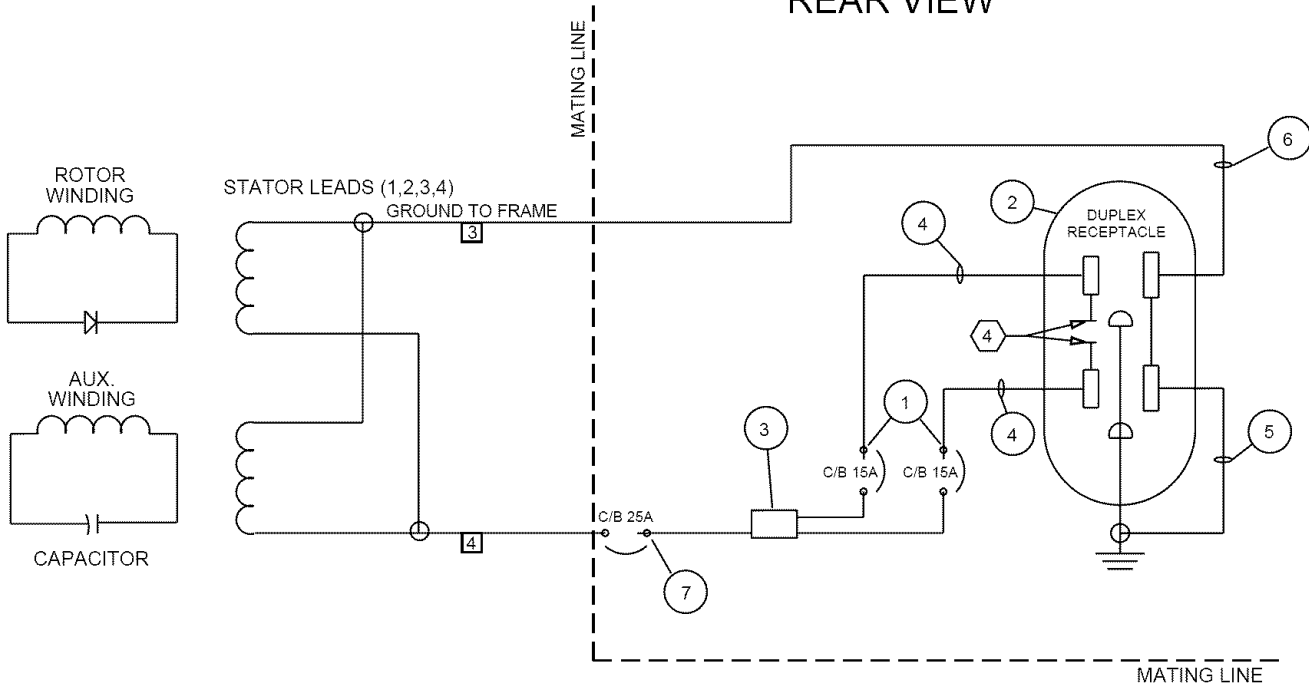

KEY

<u>NO.</u>	<u>DESCRIPTION</u>	<u>COLOR</u>	<u>PART NUMBER</u>
1	BREAKER CIRCUIT 125/250V	NA	GS-0024
2	DUPLEX 120V CANADA	NA	GS-0804
3	WIRE ASSY	NA	GS-0894
4	WIRE #12 AWG	RED	NA
5	WIRE #12 AWG	GREEN	NA
6	WIRE #12 AWG	GREEN	NA
7	CIRCUIT BREAKER 25A	NA	GS-0645

ENGINE PARTS

CRAFTSMAN 3000 GENERATOR 919.670030

BRIGGS & STRATTON MODEL #1214120175E1

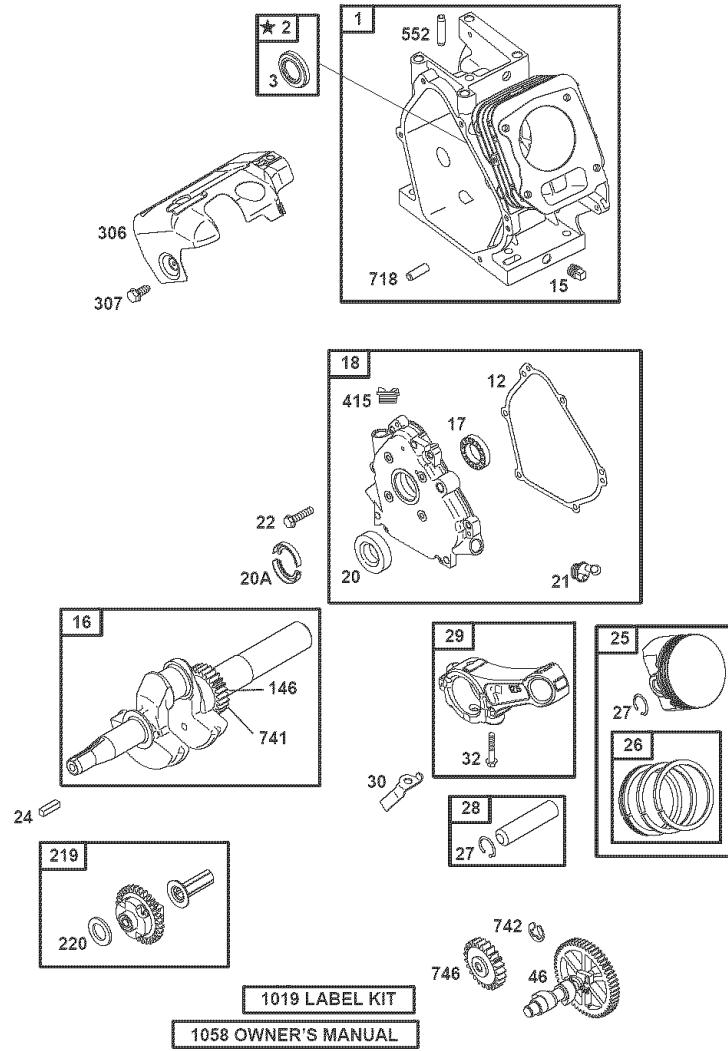

1019 LABEL KIT
1058 OWNER'S MANUAL

Key No.	Part No.	Description	Key No.	Part No.	Description
1	690045	Cylinder Assembly	27	691866	Piston Pin Lock
2	399269	Bushing/Seal Kit	28	499423	Piston Pin
3	299819	Oil Seal	29	690124	Connecting Rod
12	692549	Crankcase Gasket	30	692562	Connecting Rod Dipper
15	94916	Oil Drain Plug	32	94699	Screw (Connecting Rod)
16	694450	Crankshaft	46	693404	Camshaft
17	692517	Ball Bearing	146	94388	Timing Key
18	693605	Crankcase Cover	219	693578	Governor Spring
20	692550	Oil Seal	220	691724	Washer (Governor Gear)
20A	694171	Oil Seal	306	693610	Cylinder Shield
21	281658	Oil Fill Cap	307	690345	Screw (Cylinder Shield)
22	692551	Screw (Crankcase Cover)	415	693463	Plug
24	222698	Flywheel Key	552	692346	Governor Crank Bushing
25	499627	Piston Assembly (Standard)	718	230192	Locating Pin
25	692788	Piston Assembly (.010 O.S.)	741	692565	Timing Gear
25	692789	Piston Assembly (.020 O.S.)	742	692564	Retaining Ring
25	692790	Piston Assembly (.030 O.S.)	746	692566	Idle Gear
26	499631	Ring Set (Standard)	1019	694852	Label Kit
26	692785	Ring Set (.010 O.S.)	1058	274263	Owner's Manual
26	692786	Ring Set (.020 O.S.)			
26	692787	Ring Set (.030 O.S.)			



ENGINE PARTS

CRAFTSMAN 3000 GENERATOR 919.670030

BRIGGS & STRATTON MODEL #1214120175E1

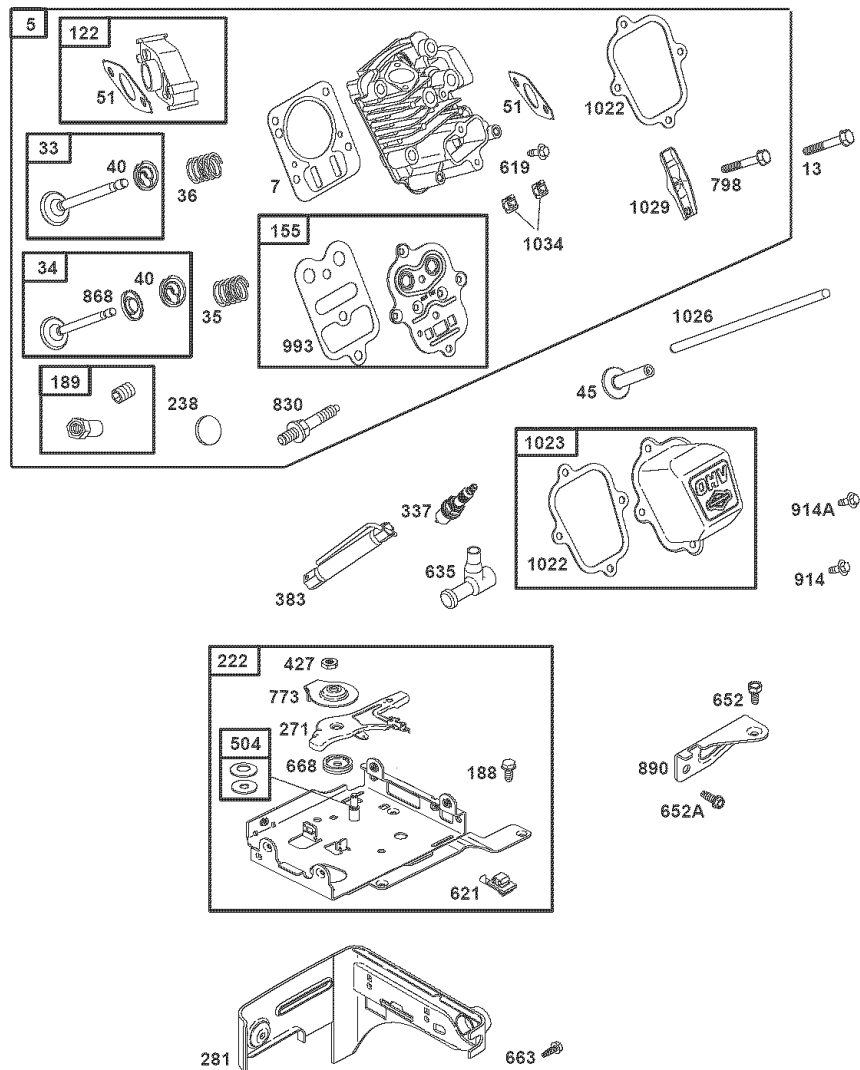

Key No.	Part No.	Description	Key No.	Part No.	Description
5	693643	Cylinder Head	619	691108	Screw (Cylinder Head Plate)
7	695166	Cylinder Head Gasket	621	396847	Stop Switch
13	691137	Screw (Cylinder Head)	635	280897	Spark Plug Boot
33	499642	Exhaust Valve	652	691108	Screw (Support Bracket)
34	499641	Intake Valve	652A	94831	Screw (Support Bracket)
35	691304	Valve Spring (Intake)	663	694593	Screw (Control Panel)
36	691304	Valve Spring (Exhaust)	668	694257	Spacer
40	93312	Valve Retainer	773	694258	Retainer
45	262679	Valve Tappet	830	694544	Stud (Rocker Arm)
51	692555	Intake Gasket	868	498592	Valve Seal
155	695168	Cylinder Head Plate	890	694933	Support Bracket
188	94644	Screw (Control Bracket)	914	692198	Screw (Rocker Cover 7/16" Long)
189	694543	Rocker Arm Ball	914A	692557	Screw (Rocker Cover 3/8" Long)
222	694253	Control Bracket	993	694088	Cylinder Head Plate Gasket
238	263131	Valve Cap	1022	691890	Rocker Cover Gasket
271	694256	Control Lever	1023	499924	Rocker Cover
281	694252	Control Panel	1026	693517	Push Rod
337	491055	Spark Plug	1029	691230	Rocker Arm
427	694255	Nut (Control Bracket)	1034	691343	Push Rod Guide
504	694254	Friction Washer Set			



ENGINE PARTS

CRAFTSMAN 3000 GENERATOR 919.670030

BRIGGS & STRATTON MODEL #1214120175E1

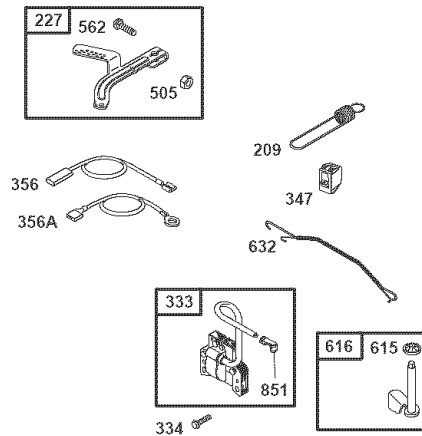
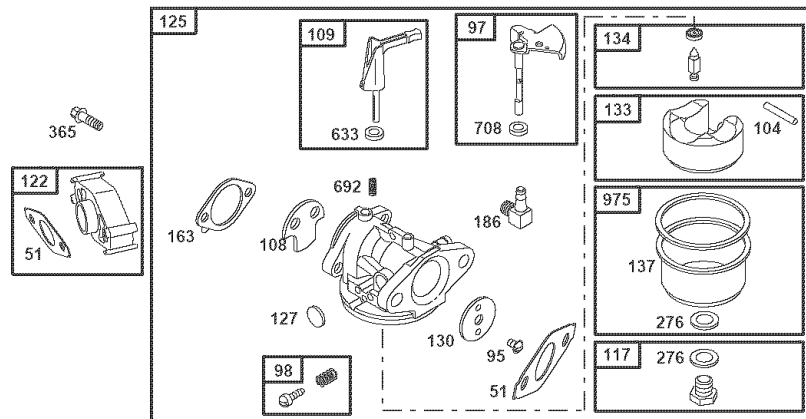

Key No.	Part No.	Description	Key No.	Part No.	Description
51	692555	Intake Gasket	227	692573	Governor Control Lever
95	94098	Screw (Throttle Valve)	276	271716	Sealing Washer
97	690024	Throttle Shaft	333	692605	Magneto Armature
98	398185	Idle Speed Kit	334	94731	Screw (Magneto Armature)
104	691242	Float Hinge Pin	347	692599	Rocker Switch
108	692567	Choke Valve	356	692602	Stop Wire
109	690023	Choke Shaft	356A	692603	Stop Wire
117	498976	Main Jet	365	692568	Screw (Carburetor)
122	693749	Carburetor Spacer	505	231082	Nut (Governor Control Lever)
125	694508	Carburetor	562	94852	87Bolt (Governor Control Lever)
127	694468	Welch Pug	615	692576	Governor Shaft Retainer
130	691203	Throttle Valve	616	692547	Governor Crank
133	398187	Carburetor Float	632	693408	Spring/Link-Mechanical Governor
134	398188	Needle/Seat Kit	633	693867	Washer (Choke Shaft)
137	280492	Float Bowl Gasket	692	690572	Detent Spring
163	272948	Air Cleaner Gasket	708	691321	Dust Seal
186	493496	Hose Connector	851	493880	Spark Plug Terminal
209	693206	Governor Spring	975	493640	Float Bowl



ENGINE PARTS

CRAFTSMAN 3000 GENERATOR 919.670030

BRIGGS & STRATTON MODEL #1214120175E1

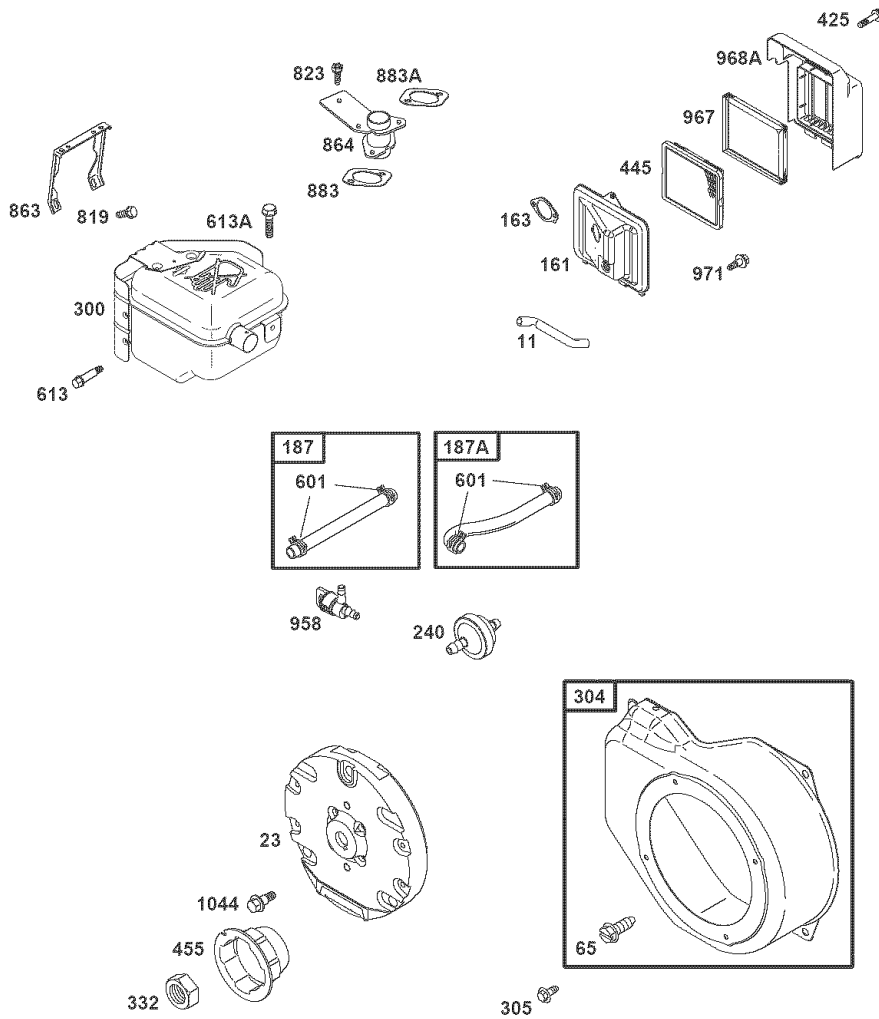

Key No.	Part No.	Description
11	692600	Breather Tube
23	692987	Flywheel
65	692680	Screw (Rewind Starter)
161	692579	Air Cleaner Base
163	272948	Air Cleaner Gasket
187	298049	Fuel Line (Cut to Required Length)
187A	692601	Fuel Line (Molded)
240	298090	Fuel Filter
300	694429	Exhaust Muffler
304	692987	Blower Housing
305	690960	Screw (Blower Housing)
332	94877	Nut (Flywheel)
425	692583	Screw (Air Cleaner Cover)
445	690610	Air Cleaner Cartridge Filter
455	692591	Flywheel Cup

Key No.	Part No.	Description
601	93053	Hose Clamp
613	694460	Screw (Exhaust Muffler)
613A	691108	Screw (Exhaust Muffler)
819	692598	Screw (Muffler Bracket)
823	94706	Screw (Muffler Adapter)
863	692596	Muffler Bracket
864	694430	Muffler Adapter
883	272309	Exhaust Gasket
883A	695167	Exhaust Gasket
958	692586	Fuel Shut-Off Valve
967	493537	Filter Pre-Cleaner
968	692584	Air Cleaner Cover
971	692583	Screw (Air Cleaner Cover)
1044	692590	Screw (Flywheel)



ENGINE PARTS

CRAFTSMAN 3000 GENERATOR 919.670030

BRIGGS & STRATTON MODEL #1214120175E1

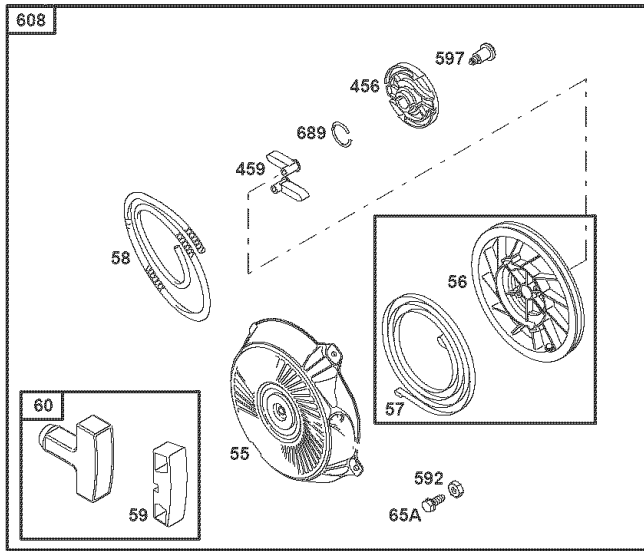

Key No.	Part No.	Description
55	691422	Rewind Starter Housing
56	498144	Starter Pulley
57	498144	Rewind Starter Spring
58	693389	Starter Rope (Cut to Required Length)
59	805957	Grip Insert
60	715257	Starter Rope Grip
65A	94904	Screw (Rewind Starter Housing)
456	281503	Pawl Friction Plate
459	281505	Ratchet Pawl
592	94908	Nut (Rewind Housing)
597	94943	Screw (Pawl Friction Plate)
608	693394	Rewind Starter
689	263073	Friction Spring

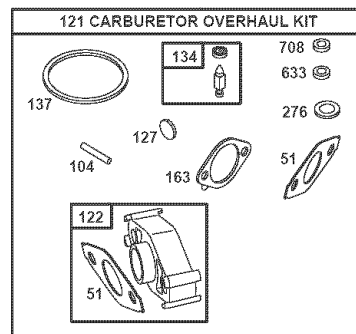
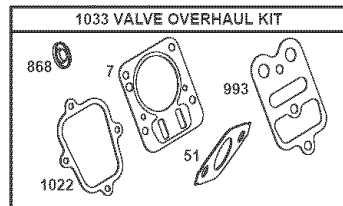
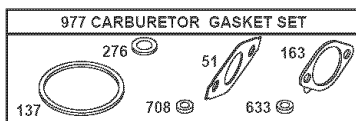
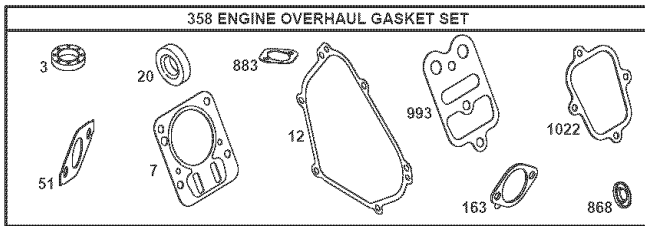

Key No.	Part No.	Description
3	299819	Oil Seal
7	695166	Cylinder Head Gasket
12	692549	Crankcase Gasket
20	692550	Oil Seal
51	692555	Intake Gasket
104	691242	Float Hinge Pin
121	695157	Carburetor Overhaul Kit
122	693749	Carburetor Spacer
127	694468	Welch Plug
134	398188	Needle/Seat Kit
137	280492	Float Bowl Gasket
163	272948	Air Cleaner Gasket
276	271716	Sealing Washer
358	695155	Engine Gasket Set
633	693867	Choke Shaft Seal
708	691321	Dust Seal
868	498592	Valve Seal
883	272309	Exhaust Gasket
977	695156	Carburetor Gasket Set
993	694088	Cylinder Head Plate Gasket
1022	691890	Rocker Cover Gasket
1033	690034	Valve Overhaul Kit



Dear Customer,

In manufacturing this product, many steps have been taken to provide you with the highest quality. Unfortunately, errors or omissions occasionally occur. In the event that you find a missing or defective part, please contact your nearest Sears store.

SERVICE AND REPAIR PARTS
CALL 1-800-665-4455 *

Keep this number handy should you require a service call or need to order repair parts.

If ordering parts make sure you have the name, make and model no. of the merchandise and the name and number of the part you wish to order.

* If calling locally, please use one of the following numbers:

Regina - 566-5124	Montreal - 333-5740
Toronto - 744-4900	Halifax - 454-2444
Kitchener - 894-7590	Ottawa - 738-4440
Vancouver - 420-8211	

If you have any suggestions that would help us to improve our assembly/operation instructions, or this product, please write them down and mail it to:

Sears Canada Inc.
222 Jarvis Street
Toronto, Ontario
M5B 2B8

Attention: Buyer Dept: D671

Model No. _____

NAME _____

ADDRESS _____

POSTAL CODE _____ PHONE # _____

COMMENTS
