

Contact our experts

support@raynic.com

**SOLAR HAND CRANK CAMPING LANTERN
NO POWER OUTAGE CONCERNS FOR OUTDOOR ACTIVITIES**

CL 7000

<https://www.raynic.com>



Version 1.0

CHAPTER 1 PRODUCT DIAGRAM

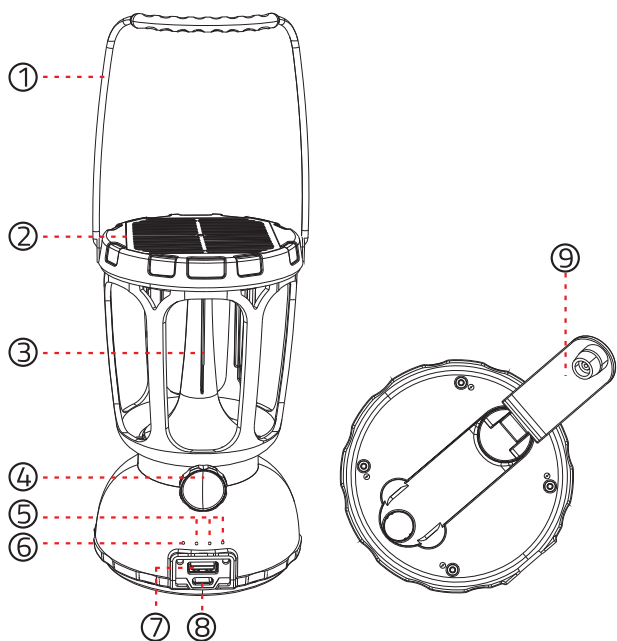

- 1. Top Handle
- 2. Solar Panel
- 3. Main Light
- 4. Dimmer Knob
- 5. Battery Indicator

- 6. Charging Indicator
- 7. USB Output Charging Port
- 8. Type-C Input Charging Port
- 9. Crank Handle

CHAPTER 2 LIGHT CONTROL

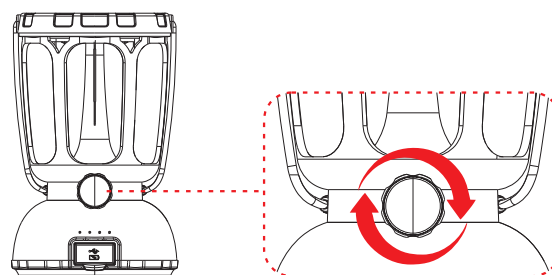

- (1) Rotate the dimmer knob clockwise, the light will turn ON after a 'tick'.
- (2) Continue to rotate the knob, the brightness will change from softer warm light to brighter white light. The brightness and tone will change gradually and fluently so you can set your preference from 0 to 100%.
- (3) Restore the dimmer knob anti-clockwise, the light will turn OFF after a 'tick'.

CHAPTER 3 POWER INDICATOR

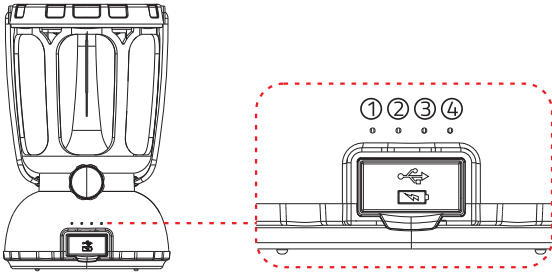

Battery Condition	Indicator
70% - 100%	● ● ●
35% - 70%	● ● ○
10% - 35%	● ○ ○
0 - 10% (low battery)	☀ ☀ ☀

■ The first little bulb is charging indicator. When the lantern is charged by type-C input port/solar panel/ hand crank handle, the charging indicator will turn red. It will turn blue when lantern is fully charged.

■ The rest of 3 little bulbs are battery capacity indicator.

Note: The battery capacity indicator will be shining when the camping lantern is in low battery condition, please link it to charging cable.

- 03 -

CHAPTER 6 POWER SUPPLY MODE

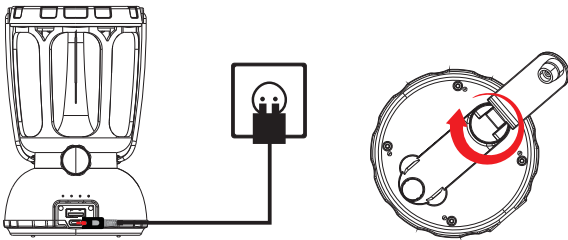

1. Hand Crank Power

(1) Unfold the crank handle from the backside and rotate it in either direction.

(2) Rotate the crank handle for 3-5 minutes. It will generate ample power and activate the build-in rechargeable battery.

NOTE: Rotate the crank handle at the speed of 2 laps per second. It will generate 300-350mA electricity.

2. Type-C Adapter Charging Input

(1) Plug the adapter (optional) into the standard outlet, and then connect to the 'Type-C Input Port' jack on the broadside.

(2) Then it will charge the built-in rechargeable battery.

NOTE: It is highly recommended to use 5V/2A adapter.

Note: 5V/2A adapter is not included.

- 05 -

CHAPTER 4 BATTERY WORKING TIME

Brightness	Low	Mid	Brighter	Brightest
Max Working Time	200 Hours	35 Hours	20 Hours	10 Hours

CHAPTER 5 USB OUTPUT CHARGING

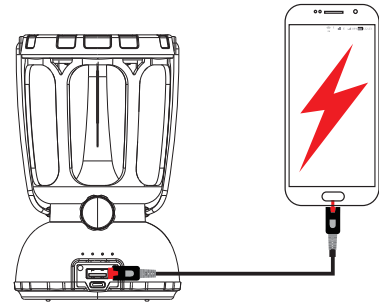

- (1) Connect your phone charging cable with the USB output port at the bottom of the lantern.
- (2) If the camping light is out of power, you can rotate the crank handle for 8-15 minutes (time depends on your speed of rotation). Then your phone will get enough power to start up.
- (3) The maximum charge current is 1 Ampere.

- 04 -

3. Solar Power

- (1) Expose the solar panel to sunlight, don't charge indoors.
- (2) It will generate 120mA electricity to charging build-in rechargeable battery.

NOTE: Solar panel will generate 120mA electricity when exposed to sunlight. It is difficult to fully charge battery with solar panel, which is mostly used for maintaining the rechargeable battery.

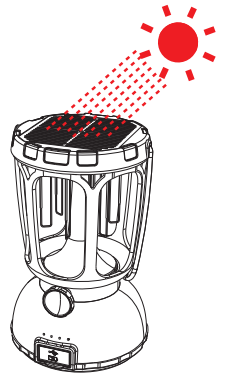

Charging Type	5V/2A Adapter	Hand Crank	Solar
Time required to fully charge	7 Hours	20 Hours	160 Hours

CHAPTER 7 MAIN FEATURES

- Warm Light Wattage: 3.5W
- Warm Light Brightness: 350LM
- Warm Light Color Temperature: 2700K
- White Light Wattage: 6.5W
- White Light Brightness: 650LM
- White Light Color Temperature: 10000-15000K
- Water Resistance: IPX4
- Built-in Battery Capacity: 6000mAh
- Power Cable: Type-C Cable

- 06 -