

Installation Guide

100/300/500 Series
Outdoor Grill Conversion Kits

IMPORTANT: PLEASE READ AND FOLLOW

1. Before beginning, please read these instructions completely and carefully.
2. Do not remove permanently affixed labels, warnings, or plates from product. This may void the warranty.
3. Please observe all local and national codes and ordinances.

CAUTION: Before proceeding with the conversion, shut off the gas supply to the appliance prior to disconnecting the electrical power.

⚠ WARNING

This conversion kit shall be installed by a qualified service agency in accordance with the manufacturer's instructions and all applicable codes and requirements of the authority having jurisdiction. If the information in these instructions is not followed exactly, a fire, explosion or production of carbon monoxide may result causing property damage, personal injury or loss of life. The qualified service agency is responsible for the proper installation of this kit. The installation is not proper and complete until the operation of the converted appliance is checked as specified in the manufacturer's instructions supplied with the kit.

GAS CONVERSION

To convert a grill from natural to LP/Propane gas or LP/Propane to natural, you must use the conversion kit supplied by the manufacturer. When converting to Natural Gas, use the NKVGBQ kit for VGBQ/CVGBQ models and NKVGIQ kit for VGIQ/CVGIQ models. When converting to LP/Propane, use the LPKVGBQ kit for VGBQ/CVGBQ models and LPKVGIQ kit for VGIQ/CVIQ models. Conversions should only be done by an authorized service technician.

NOTE: WHEN THE CONVERSION IS COMPLETED, THE CONVERSION LABEL MUST BE PLACED NEXT TO THE RATING LABEL UNDER THE DRIP TRAY IN THE REAR LEFT CORNER NEXT TO THE INLET PIPE.

FOR T/T1/E AND 100/300 SERIES GRILLS

Depending on the grill model, all orifices in the kit may not be used.

TNKVGBQ Conversion Kit Part List

- (1) Natural Regulator Assembly
- (1) Natural Orifice Kit
 - (3) #40 Grill Burner Orifices
 - (2) #51 Smoker Burner Orifice
 - (2) #49 Side Burner Orifices
 - (2) #48 Infrared Burner Orifices
- (1) Natural Conversion Kit Label

TLPKVGBQ Conversion Kit Part List

- (1) LP/Propane Regulator Assembly
- (1) LP/Propane Orifice Kit
 - (3) #54 Grill Burner Orifices
 - (2) #62 Smoker Burner Orifice
 - (3) #57 Side Burner/Infrared Burner Orifices
- (1) LP/Propane Conversion Kit Label

TNKVGIQ Conversion Kit Part List

- (1) Natural Regulator Assembly
- (1) Natural Orifice Kit
 - (2) #40 Grill Burner Orifices
 - (2) #51 Smoker Burner Orifice
 - (2) #49 Side Burner Orifices
 - (2) #48 Infrared Burner Orifices
 - (1) TruSear™ Infrared Burner Valve
- (1) Natural Conversion Kit Label

TLPKVGIQ Conversion Kit Part List

- (1) LP/Propane Regulator Assembly
- (1) LP/Propane Orifice Kit
 - (2) #54 Grill Burner Orifices
 - (2) #62 Smoker Burner Orifice
 - (3) #57 Side Burner/Infrared Burner Orifices
 - (1) TruSear™ Infrared Burner Valve
- (1) LP/Propane Conversion Kit Label



VGBQ/CVGBQ T/T1/E AND 100/300 SERIES CONVERSIONS

To convert grill burners, side burner and smoker burner:

1. Remove all grates, flavor generators and stainless steel burners from the unit.
2. Look into the burner box back toward the control panel in order to locate the orifice hoods. Remove the gas orifice hoods located on the grill burner valves.
3. Replace the orifice hoods with the correct gas orifice hoods supplied in the conversion kit. (See chart)
4. Replace the stainless steel burners, flavor generators and grates.

	Natural Orifice Hood	LP/Propane Orifice Hood
Grill Burners	(3) - 40	(3) - #54
Smoker Burners	(2) - #51	(2) - #62
Side Burners	(2) - #49	(2) - #57

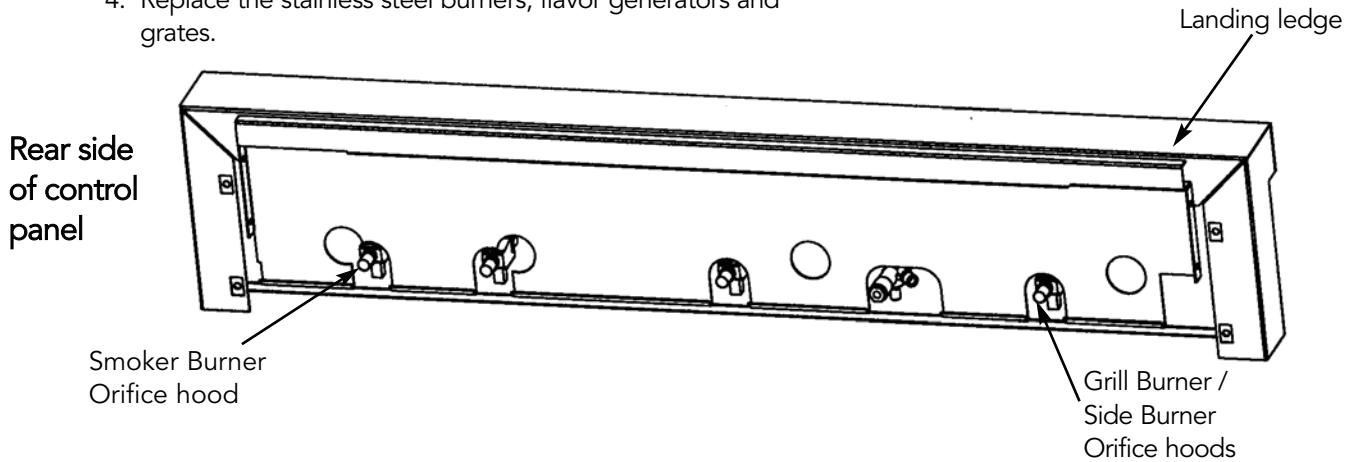

To convert the rotisserie infrared burner:

1. Remove the back cover from the unit to expose the orifice hood to the infrared burner.
2. Remove the gas orifice hood located on the grill.
3. Replace with the gas orifice hood supplied in the conversion kit.
4. Replace the back cover.

	Natural Orifice Hood	LP/Propane Orifice Hood
Infrared Burner	(1) or (2) - #48	(1) or (2) - #57

Depending on grill model

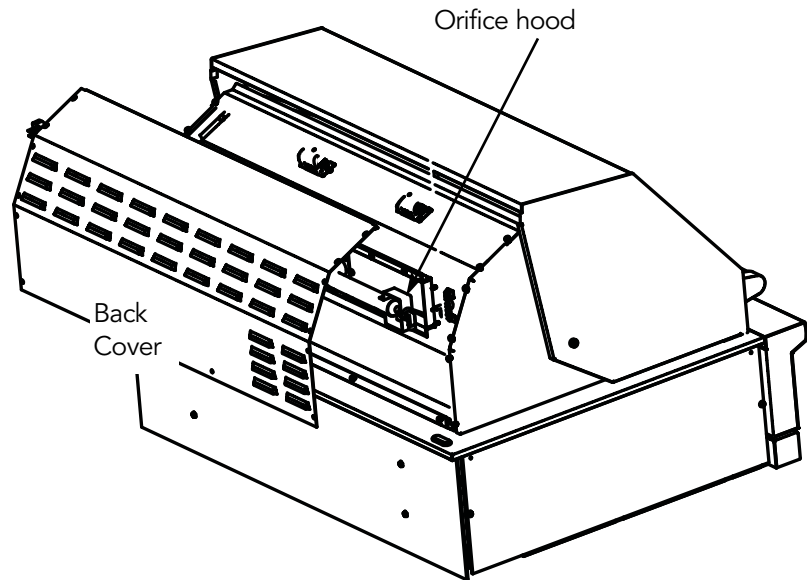

To check LP/Propane to Natural Conversion of the rotisserie infrared burner:

Ignite the rotisserie burner and set it to low. If the burner will not hold a flame, it will be necessary to adjust the low setting. Remove the control panel to expose the rotisserie safety valve. Using a small flat head screwdriver turn the adjustment screw counterclockwise. Visually check the flame. When the burner is able to hold a flame on the low setting, the setting is complete. Replace the control panel.

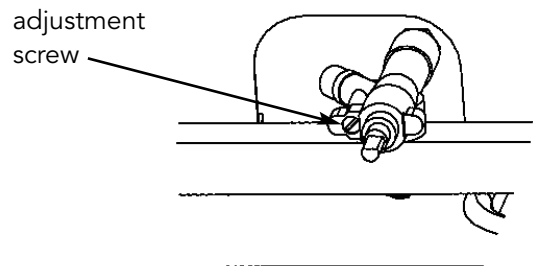

NOTE: For installation in areas with altitudes greater than 2000 feet, the orifices must be derated at 4% for every 1000 feet above 2000 feet.

FOR E1/E2 AND 500 SERIES GRILLS

Depending on the grill model, all orifices in the kit may not be used.

- E1NKVGBQ Conversion Kit Part List**
- (1) Natural Regulator Assembly
 - (1) Natural Orifice Kit
 - (3) #37 Grill Burner Orifices
 - (2) #49 Smoker Burner Orifice
 - (2) #49 Side Burner Orifices
 - (2) #48 Infrared Burner Orifices
 - (1) Natural Conversion Kit Label

- E1LPKVGBQ Conversion Kit Part List**
- (1) LP/Propane Regulator Assembly
 - (1) LP/Propane Orifice Kit
 - (4) #52 Grill Burner Orifices
 - (2) #57 Smoker Burner Orifice
 - (3) #57 Side Burner/Infrared Burner Orifices
 - (1) LP/Propane Conversion Kit Label

- E1NKVGIQ Conversion Kit Part List**
- (1) Natural Regulator Assembly
 - (1) Natural Orifice Kit
 - (2) #37 Grill Burner Orifices
 - (2) #49 Smoker Burner Orifice
 - (2) #49 Side Burner Orifices
 - (2) #48 Infrared Burner Orifices
 - (1) TruSear™ Infrared Burner Valve
 - (1) Natural Conversion Kit Label

- E1LPKVGIQ Conversion Kit Part List**
- (1) LP/Propane Regulator Assembly
 - (1) LP/Propane Orifice Kit
 - (2) #52 Grill Burner Orifices
 - (2) #57 Smoker Burner Orifice
 - (3) #57 Side Burner/Infrared Burner Orifices
 - (1) TruSear™ Infrared Burner Valve
 - (1) LP/Propane Conversion Kit Label

VGBQ/CVGBQ E1/E2 500 SERIES CONVERSIONS

To convert grill burners, side burner and smoker burner:

1. Remove all grates, flavor generators and stainless steel burners from the unit.
2. Look into the burner box back toward the control panel in order to located the orifice hoods. Remove the gas orifice hoods located on the grill burner valves.
3. Replace the orifice hoods with the correct gas orifice hoods supplied in the conversion kit. (See chart)
4. Replace the stainless steel burners, flavor generators and grates.

	Natural Orifice Hood	LP/Propane Orifice Hood
Grill Burners	(4) - #37	(4) - #52
Smoker Burners	(2) - #49	(2) - #57
Side Burners	(2) - #49	(2) - #57

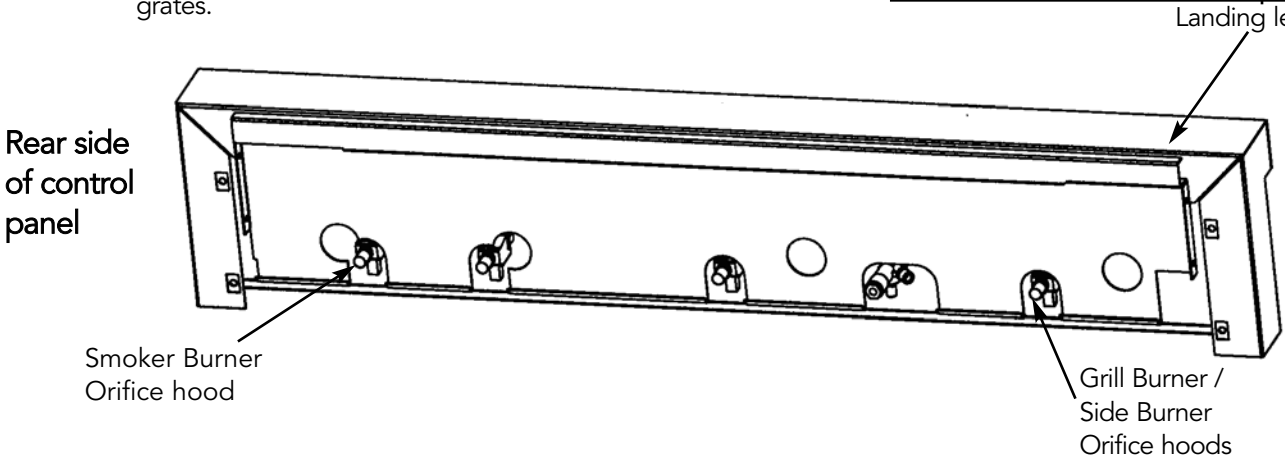

To convert the rotisserie infrared burner:

1. Remove the back cover from the unit to expose the orifice hood to the infrared burner.
2. Remove the gas orifice hood located on the grill.
3. Replace with the gas orifice hood supplied in the conversion kit.
4. Replace the back cover.

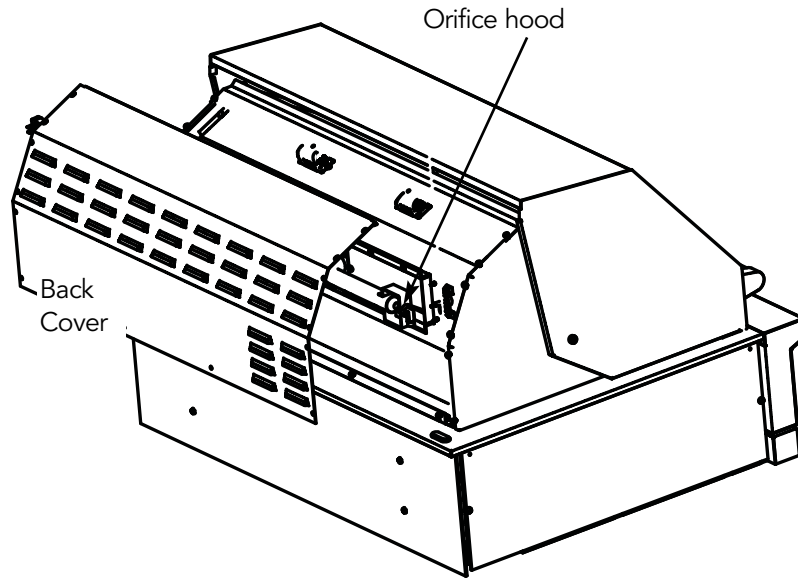

	Natural Orifice Hood	LP/Propane Orifice Hood
Infrared Burner	(1) or (2) - #48	(1) or (2) - #57

Depending on grill model

To check LP/Propane to Natural Conversion of the rotisserie infrared burner:

Ignite the rotisserie burner and set it to low. If the burner will not hold a flame, it will be necessary to adjust the low setting. Remove the control panel to expose the rotisserie safety valve. Using a small flat head screwdriver turn the adjustment screw counterclockwise. Visually check the flame. When the burner is able to hold a flame on the low setting, the setting is complete. Replace the control panel.

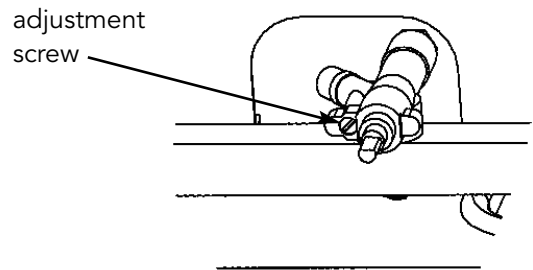

NOTE: For installation in areas with altitudes greater than 2000 feet, the orifices must be derated at 4% for every 1000 feet above 2000 feet.

VGIQ/CVGIQ E1/E2 AND 500 SERIES CONVERSIONS

To convert grill burners, TruSear™ burner, side burner and smoker burner:

1. Remove all grates, flavor generators and stainless steel burners from the unit except for ones over TruSear™ infrared burner.
2. Remove control panel to expose the burner valves. Remove the orifice hoods located on the valve for the grill burners, side burners, and smoker burner.
3. Replace the orifice hoods with the correct gas orifice hoods supplied in the conversion kit for the grill burners, side burners, and smoker burners. The complete burner valve will have to be replaced on the TruSear™ infrared burner. (See chart)
4. Replace the stainless steel burners, flavor generators and grates.

	Natural Orifice Hood	LP/Propane Orifice Hood
Grill Burners	(2) - #37	(2) - #52
Smoker Burners	(2) - #49	(2) - #57
Side Burners	(2) - #49	(2) - #57
TruSear™ Infrared Burner	(1) - #35	(1) - #51

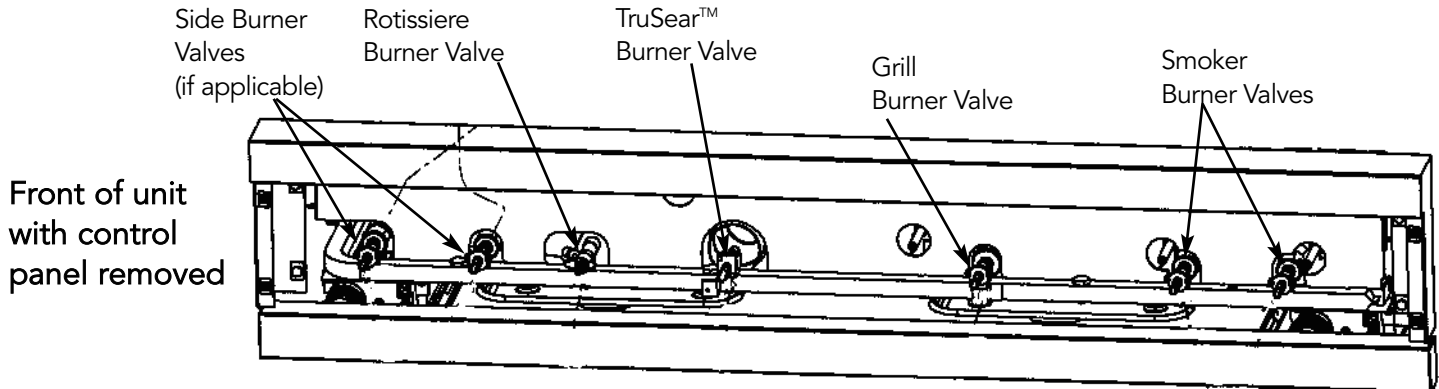

To convert the rotisserie infrared burner:

1. Remove the back cover from the unit to expose the orifice hood to the infrared burner.
2. Remove the gas orifice hood located on the grill.
3. Replace with the gas orifice hood supplied in the conversion kit.
4. Replace the back cover

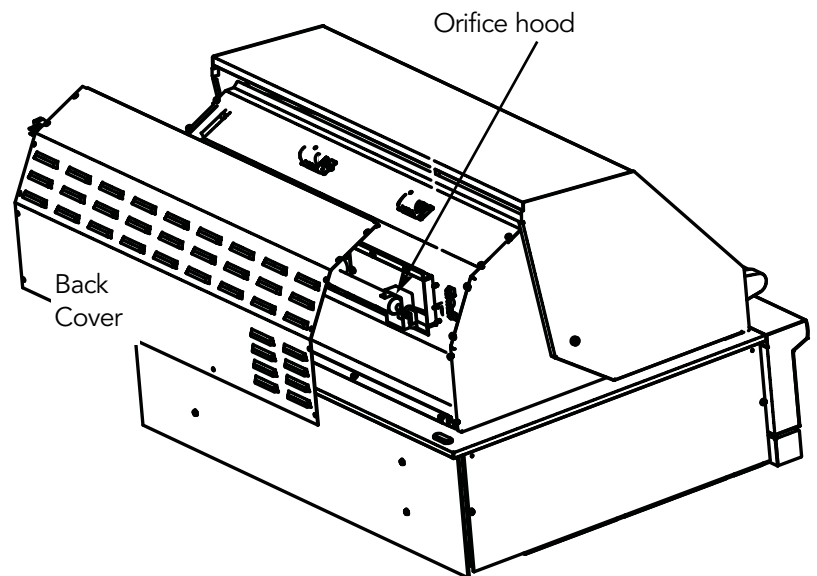

	Natural Orifice Hood	LP/Propane Orifice Hood
Infrared Burner (20")	(1) or (2) - #48	(1) or (2) - #57

To check LP/Propane to Natural Conversion of the rotisserie infrared burner:

With the control panel off, Ignite the rotissere burner and set it to low. If the burner will not hold a flame, it will be necessary to adjust the low setting. Remove the control panel to expose the rotissiere safety valve. Using a small flat head screwdriver turn the adjustment screw counterclockwise. Visually check the flame. When the burner is able to hold a flame on the low setting, the setting is complete. Replace the control panel.

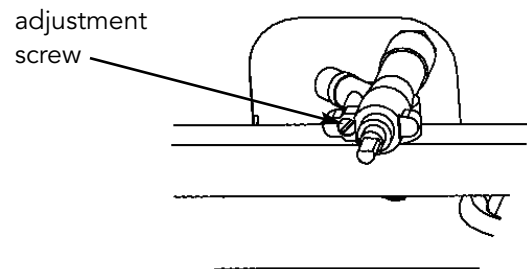

NOTE: For installation in areas with altitudes greater than 2000 feet, the orifices must be derated at 4% for every 1000 feet above 2000 feet.

Natural or LP/Propane Connection

Natural Fixed Connection: Standard Residential 1/2" gas service line - 1/2" NPT male with 7/8" flare adapter.
4.0" W.C.P. Operating Pressure / 6" to 10" W.C.P. Supply Pressure

LP/Propane Fixed Connection: Standard Residential 1/2" gas service line - 1/2" NPT male with 3/8" flare adapter.
10.0" W.C.P. Operating Pressure / 11" to 14" W.C.P. Supply Pressure

LP/Propane Cylinder Connection: 1/2" NPT male with 3/8" flare adapter
10.0" W.C.P. Operating Pressure

The installer must check the supply pressure and operating pressure. To check operating pressure, remove one burner and hook a manometer to the orifice hood. Ignite one of the remaining burners and turn the valve for the removed burner to high. Read the pressure on the manometer.

Check with your local gas utility company or with local codes for instructions on installing gas supply lines. Be sure to check on type and size of run, and how deep to bury the line. If the gas line is too small, the unit will not function properly. Any joint sealant used must be an approved type and be resistive to the actions of natural gas.

Leak Testing

Although all gas connections on the grill are leak tested at the factory prior to shipment, a complete gas tightness check must be performed at the installation due to possible mishandling in shipment or excessive pressure unknowingly being applied to the unit. Periodically check the whole system for leaks, or immediately check if the smell of gas is detected.

- Do not smoke while leak testing.
- Extinguish all flames.
- Never leak test with an open flame

⚠ CAUTION

Before placing into operation, always check for gas leaks with a soapy water solution. **DO NOT USE AN OPEN FLAME TO CHECK FOR LEAKS.**



Make a soap solution of one part liquid detergent and one part water. You will need a spray bottle, brush or towel to apply the solution to the fittings.

Note: For LP/Propane units, check with a full cylinder.

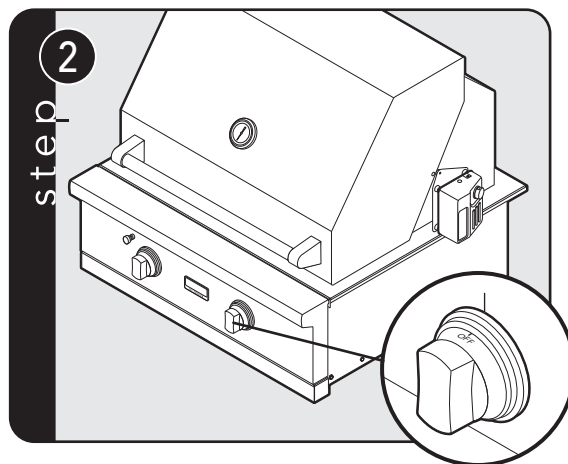

Check that all control knobs are in the "OFF" position.

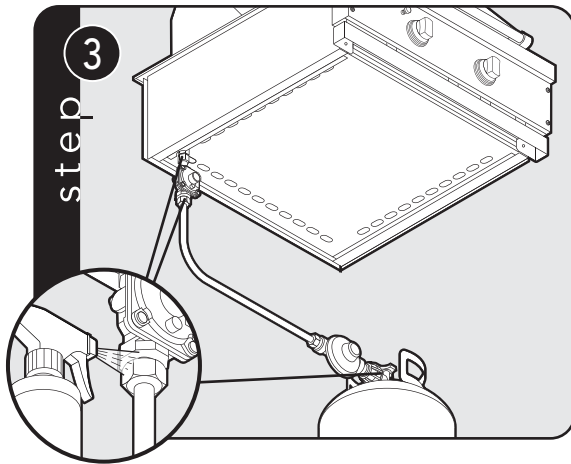

Apply the soap solution to fittings.

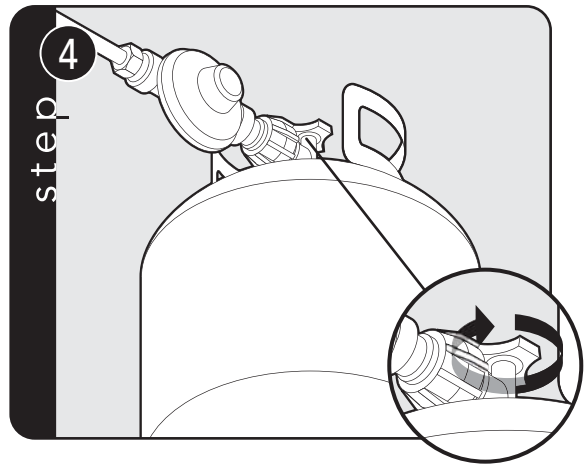

Turn cylinder valve knob counter clockwise one turn to open.

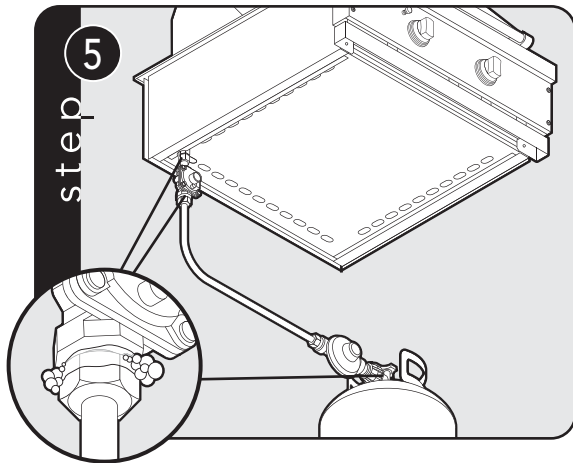

Bubbling bubbles in the soap solution indicates that a leak is present.

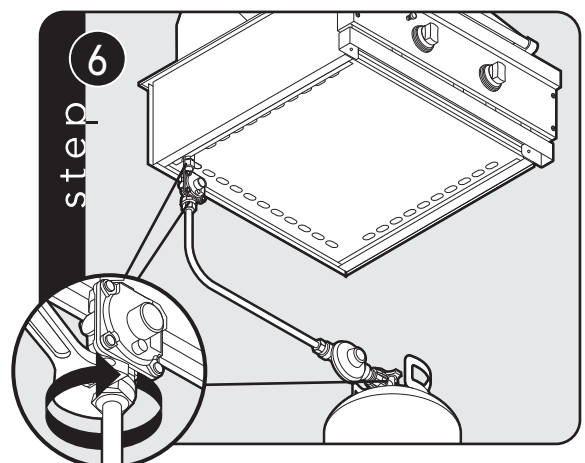

Stop a leak by tightening the loose joint or by replacing the faulty part with a replacement part recommended by the manufacturer.

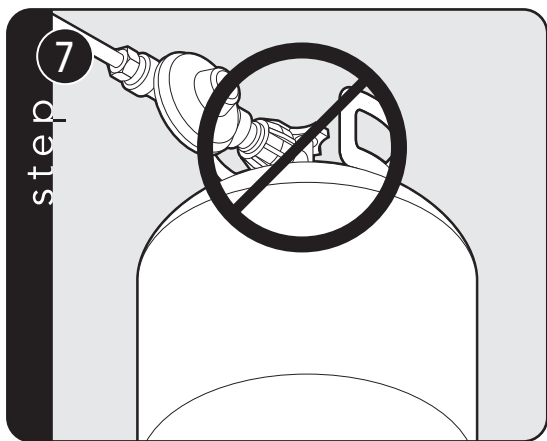

Do not attempt to repair the cylinder valve if it should become damaged. The cylinder must be replaced.

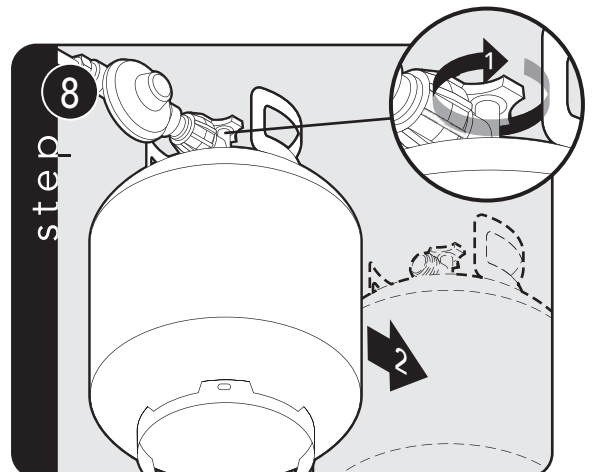

If you are unable to stop a leak, shut off the gas at the cylinder valve. Remove the cylinder from the grill.

Call an authorized gas
appliance service technician
or LP/Propane gas dealer.

Do not use the grill until
the leak is corrected.

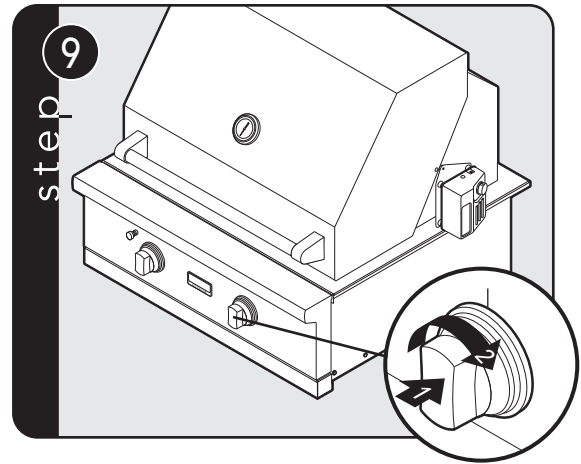

After checking for leaks, push in and turn any control
knob to release the pressure in the hose and manifold.
Turn off the control knob.

INITIAL IGNITION OF BURNERS

All burners are tested before leaving the factory. Field adjustments may be necessary for proper mixture of gas and air for proper operation. When the grill is connected to the gas service, it should be adjusted by a qualified technician. For lighting instructions, refer to the Outdoor Gas Grill Use and Care Manual.

BURNER ADJUSTMENT

Each burner is tested and adjusted at the factory prior to shipment; however, variations in the local gas supply may make it necessary to adjust the burners. The flames of the burners (except the rotisserie infrared and TruSear™ infrared burner) should be visually checked and compared with Fig. 1, Fig. 2, and Fig. 3.

Flames should be blue and stable with no yellow tips, excessive noise or lifting. If any of these conditions exist, check if the air shutter or burner ports are blocked by dirt, debris, spider webs, etc. With a proper flame height, adjust the air shutter to obtain a blue flame with no yellow tipping that sits on the burner at the burner ports. The air shutter is locked in place by a set screw which must be loosened prior to lighting the burner for adjustments.

To access the air shutter on the grill burners and smoker burner, remove the valve panel. To access the air shutter on the side burners, remove the grates, burner bowls, and grate support. With a screw driver, loosen the lock-screw on the face of the air shutter. Light the burner and adjust according to the directions below.

1. If the flame is yellow, turn the air shutter counter clockwise to allow more air to the burner.
2. If the flame is noisy and lifting away from the burner, turn the air shutter clockwise to reduce the amount of air to the burner.

Once adjusted, turn the burner off, tighten the set screw on the air shutter, replace the valve panel for the grill burners and the grate support, burner bowls, and grates for the side burners.

To ensure proper installation of the grill burners, side burners, and smoker burner:

1. Slide opening in air shutters over the orifice located in the front of the grill.
2. For the smoker burner, secure back of the burner by placing over screw slot on rear of grill and replacing screw.

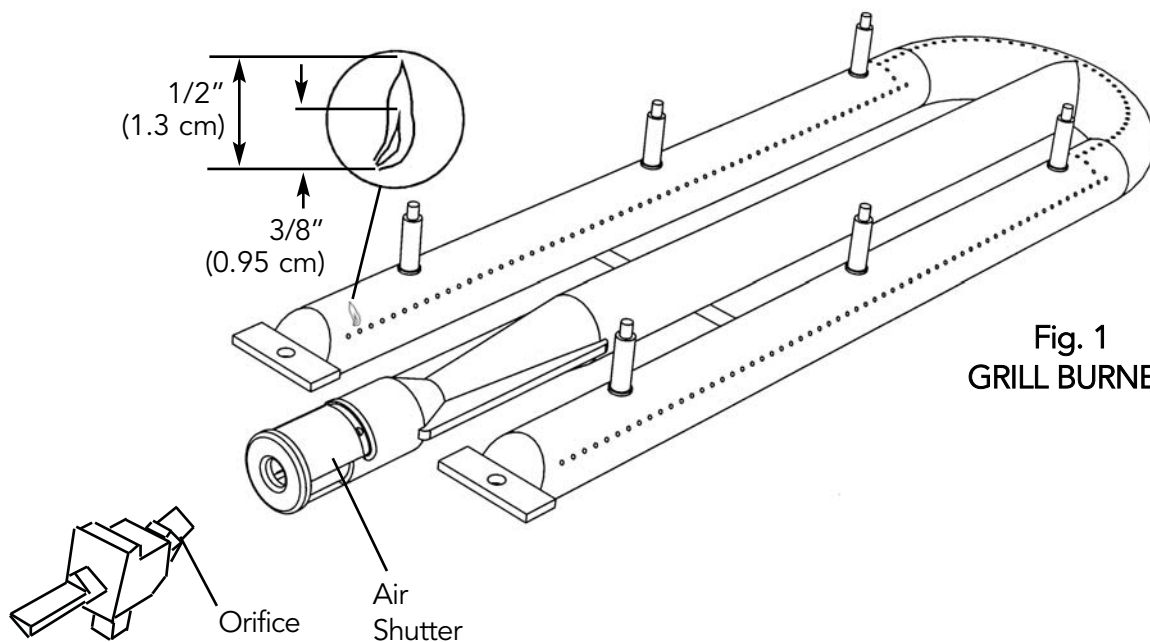

Fig. 1
GRILL BURNER

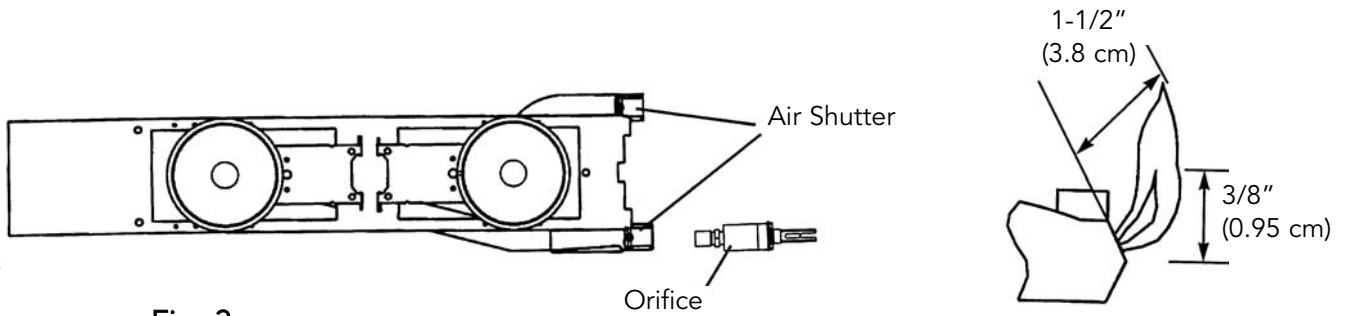
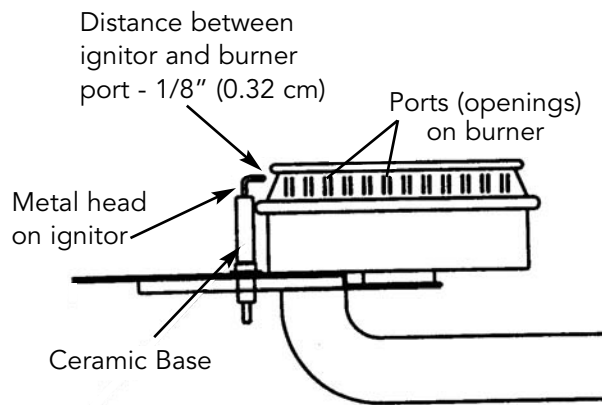

Fig. 3
SIDE BURNER
 (If applicable)

Spark Ignitor Adjustment

Occasionally a burner may not ignite within a few seconds after turning the appropriate control knob counter-clockwise. To adjust the spark ignitor, use a small needle nose plier to turn the metal head of the ignitor towards the port (opening) on the burner. **DO NOT TURN THE IGNITOR BY THE CERAMIC BASE.** This could cause damage to the spark ignitor.



Viking Range, LLC
111 Front Street
Greenwood, Mississippi 38930 USA
(662) 455-1200

For product information,
call 1-888-845-4641

