

GoWISEUSA®

AIR FRYER OVEN **SELECT**

USER MANUAL

Model No.: GW46690



Please read through this manual carefully before use

 **IMPORTANT SAFEGUARDS AND TIPS**

WWW.GOWISEUSA.COM

THANK YOU FOR YOUR PURCHASE!

Join

the GoWISE Community on Facebook, Instagram, Twitter, and Pinterest for updates, tips, and great deals!



Explore

our recipes at www.gowiseproducts.com/blogs/recipes



Contact Our Customer Care Team

855-233-9199

support@gowiseusa.com

Live Chat at gowiseusa.com

M-F 8:30am - 4:00pm MST



Register Your Product

www.gowiseproducts.com/apps/product-registration

(Normally the serial number is on the bottom of the product. Please check there first.)



Specifications

Voltage: 120V, 60Hz

Watts: 1700W

Capacity: 12.7 Qt

Temp. Range: 120°F-400°F



TABLE OF CONTENTS

Register Your Product.....	2
Specifications.....	2
Important Safeguards.....	4
Important.....	7
Overheating Protection.....	7
Electric Power.....	7
Electromagnetic Fields.....	7
Parts and Accessories.....	8
Control Display.....	10
Set Up and Using Air Fryer Oven.....	12
Before First Use.....	12
Removable Oven Door.....	12
Using Your Accessories.....	13
Cooking Guide.....	17
Internal Temperature Chart.....	17
Tips.....	17
Trussing a Whole Chicken.....	18
Rotisserie Roast a Whole Chicken.....	20
Error Codes & Troubleshooting.....	21
Warranty.....	22

IMPORTANT SAFEGUARDS

HOUSEHOLD USE ONLY • READ ALL INSTRUCTIONS BEFORE USE

- 1. NEVER IMMERSE** the main unit housing in water, as it contains electrical components and heating elements. Do not rinse under the tap.
- 2. TO AVOID ELECTRIC SHOCK, DO NOT** put liquid of any kind into the main unit housing containing the electrical components.
- This appliance has a polarized plug (one prong is wider than the other). This plug is intended to fit into a polarized outlet only one way. **TO AVOID ELECTRIC SHOCK, DO NOT** force the plug into the outlet if it does not fit. If the plug does not fit fully into the outlet, reverse the plug. If it still does not fit, contact a qualified electrician. **DO NOT ATTEMPT** to modify the plug in any way.
- Always make sure that the plug is inserted into the wall socket properly and without any other appliances on the same outlet.
- To prevent food being in contact with the heating element, **DO NOT OVERFILL** any of the cooking trays.
- DO NOT COVER OR BLOCK** the air intake vent or air outlet vent while the **GoWISE USA Air Fryer Oven** is in operation. Doing so prevents even cooking and may damage the unit or cause it to overheat.
- 7. NEVER POUR** oil into the square accessory basket. This could result in fire or personal injury.
- While cooking, the internal temperature of the unit reaches several hundred degrees Fahrenheit. **TO AVOID PERSONAL INJURY**, never place hands inside the unit unless it has thoroughly cooled.
- This appliance is **NOT INTENDED FOR USE** by persons with reduced physical, sensory, or mental capabilities or persons with a lack of experience and knowledge unless they are **UNDER THE SUPERVISION** of a responsible person or have been giving proper instruction to use the appliance. This appliance is **NOT INTENDED FOR USE** by children.
- When cooking, **DO NOT PLACE** the appliance against a wall or other appliances. Leave at least five inches of free space along the back, sides, and above the appliance. Do not place anything on top of the appliance.
- DO NOT USE** this unit if the plug, the power cord, or the appliance itself is damaged in any way.
- DO NOT PLACE** the unit on stove top surfaces.
- If the power cord is damaged, **YOU MUST HAVE IT REPLACED**

IMPORTANT SAFEGUARDS

HOUSEHOLD USE ONLY • READ ALL INSTRUCTIONS BEFORE USE

by the manufacturer, its service agent, or similarly qualified person to avoid hazard.

14. Keep the appliance and its power cord **OUT OF THE REACH** of children when it is in operation or during the cooling process.
15. **KEEP THE POWER CORD AWAY** from hot surfaces. **DO NOT PLUG** in the power cord or operate the unit controls with wet hands.
16. **NEVER CONNECT** this appliance to an external timer switch or separate remote control system.
17. **NEVER USE** this appliance with an extension cord of any kind.
18. **DO NOT OPERATE** the appliance on or near flammable materials, such as tablecloths and curtains.
19. **DO NOT USE** the **GoWISEUSA Air Fryer Oven** for any purpose other than described in this manual.
20. **NEVER OPERATE** the appliance unattended.
21. **KEEP YOUR HANDS AND FACE** at a safe distance from the air outlet vent, as hot air is released through it while in operation. Also, avoid the vent while removing the square fry basket (sold separately) from the appliance. The unit's outer surfaces may become hot during use. **USE OVEN MITTS** or use the rotisserie tongs when handling hot components. Always use oven mitts when handling hot objects and surfaces.
22. If the unit emits black smoke, **UNPLUG IMMEDIATELY** and wait for smoking to stop before removing oven contents.
23. When the time has run out during a cooking cycle, cooking will stop, but the fan **WILL CONTINUE RUNNING** for 20 seconds to cool down the unit.
24. Always operate the appliance on a horizontal surface that is level, stable, and noncombustible.
25. If the **GoWISE USA Air Fryer Oven** is used improperly, for professional or semi-professional purposes, or if it is not used according to the instructions in this user manual, the warranty becomes invalid, and the manufacturer will not be held liable for damages.
26. Always unplug the appliance after use.
27. Let the appliance cool down for approximately 30 minutes before handling, cleaning, or storing.
28. This appliance is intended for normal household use only. It is not intended for use in commercial or retail environments.

IMPORTANT SAFEGUARDS

HOUSEHOLD USE ONLY • READ ALL INSTRUCTIONS BEFORE USE

29. Please note that this unit is constantly emitting heat through the air vents, the unit must be placed on a heat resistant surface. It is the end-user's responsibility to verify the heat capacity of their countertops. We recommend using a silicone pad or spare, non-artificial tile to protect your countertops from heat damage. **The care and use of countertops is the responsibility of the end user.**

MAKE SURE THE UNIT RESTS ON A FLAT LEVEL SURFACE 5 INCHES AWAY FROM ANY OTHER WALL OR APPLIANCE AND WELL AWAY FROM ANY CURTAINS, FABRICS, OR CLOTHS.

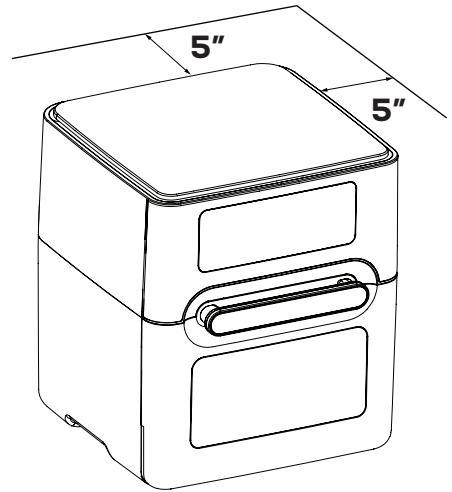

**SAVE THESE
INSTRUCTIONS**

IMPORTANT SAFEGUARDS

Important

- Before initial use and after subsequent use, hand wash all included accessories. Wipe the outside and inside of the Unit with a warm moist cloth and mild detergent. Preheat the Unit for a few minutes to burn off any residue.
- **NOTE:** The oven may emit white smoke the first time it is used. It is not defective, and the smoke will burn off within a few minutes.

Overheating Protection

Should the inner temperature control system fail, the overheating protection system will be activated and display "E3" on the control panel, and the unit will not function. To get rid of the error, unplug the unit and allow time for it to cool down completely. Once the unit has cooled, you can plug it back in and the error code should be gone, and your Air Fryer Oven is ready to use again.

Electric Power

If the electrical circuit is overloaded with other appliances, your unit may not operate properly. It should be operated on a dedicated electrical circuit.

Electromagnetic Fields

This appliance complies with all standards regarding electromagnetic fields. According to the instructions in this manual, the appliance is safe to use based on scientific evidence available today if handled properly.

PARTS AND ACCESSORIES

PARTS

1. Top Air Intake Vent
2. Control Display
3. Unit Housing
4. Internal Heating Compartment
5. Oven Door
6. Air Outlet Vent
7. Cord Organizer

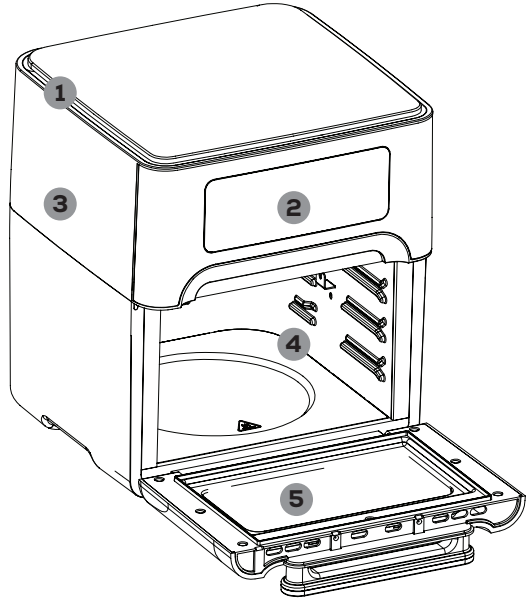

Unit Dimentions:

Outside: 12" x 12" x 14.25"

Inside: 9.75" x 10" x 7"

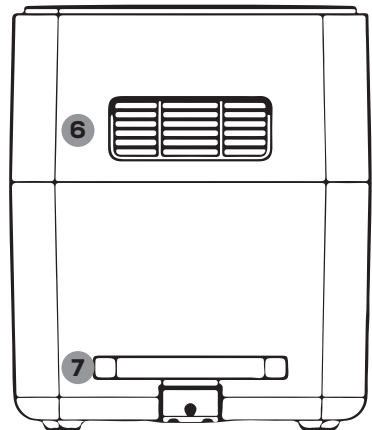

PARTS AND ACCESSORIES

ACCESSORIES

1. Rotisserie Tong
2. Rotisserie Forks
3. Rotisserie Cage
4. Rotisserie Skewers
5. Mesh Basket
6. Mesh Tray X2
7. Drip Pan
8. Silicone Mitts

NOTE: Rotisserie Forks and Skewers share one (1) rod.

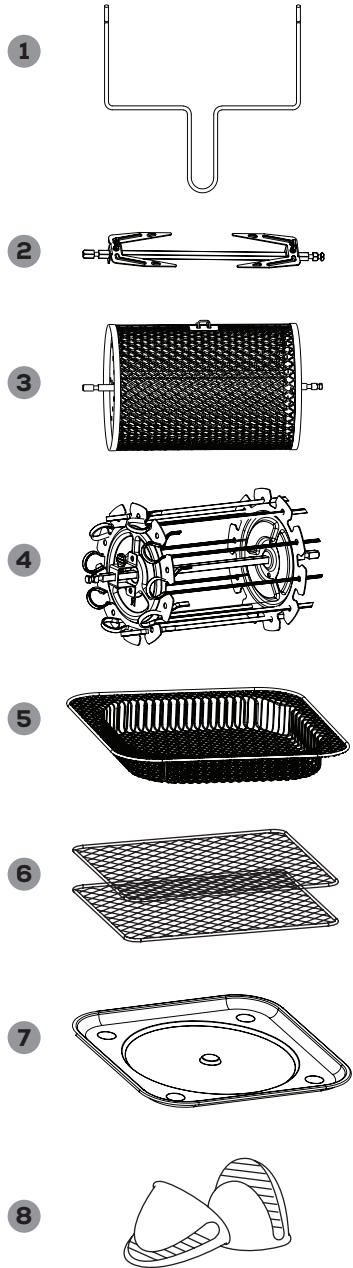

CONTROL DISPLAY

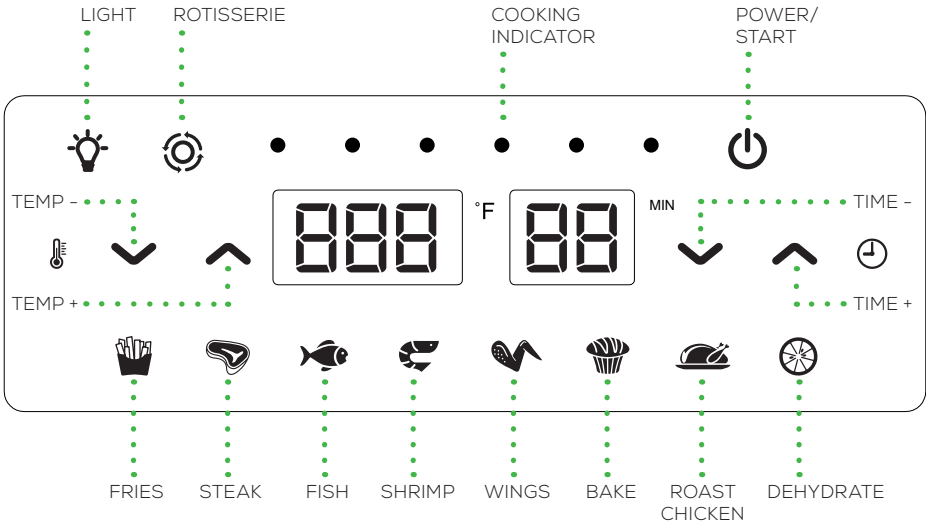

BUTTONS

POWER: Powers the unit on and off, and starts cooking cycles.

ROTISSERIE: Activates the Rotisserie function.

LIGHT: Turns the internal cooking light on or off.

UP & DOWN arrows: Increase or decrease TEMP or TIME.

PRESET BUTTONS

Fries: 18 minutes at 400°F

Steak: 12 minutes at 355°F

Fish: 15 minutes at 400°F

Shrimp: 10 minutes at 320°F

Wings: 20 minutes at 390°F

Bake: 30 minutes at 350°F

Roast Chicken: 30 minutes at 400°F

Dehydrate: 6 hours at 130°F

CONTROL DISPLAY

USING THE DIGITAL CONTROLS

1. Once the unit is plugged in, the POWER button will light up red.
2. Press the POWER/START button once to turn on the oven. The display will show the default temperature of 355°F and time of 15 minutes.

3. Manual:

Use the up and down arrows on each side of the display to select time and temperature settings. Press the POWER/START button to start the cooking process.

Preset:

Press the icon of your desired preset. The default time and temperature for that preset will display on the screen. Press the up and down arrows next to the time icon to adjust the timer. **NOTE:** All presets except for Dehydrate allow you to select a cooking time between 1 and 60 minutes.

Press the up and down arrows next to the temperature icon to adjust the temperature settings.

NOTE: The temperature setting increases and decreases in 5-degree increments between 120°F and 400°F.

4. Press the POWER/START button to start the cooking cycle. The timer will begin counting down in 1 minute increments until the end of the cooking cycle. The icon of the selected preset will flash during the cooking cycle. **NOTE:** The 6 dots at the top of the display is the cooking indicator. They will change from

flashing to solid one by one from left to right to indicate that the cooking cycle has started.

5. To make adjustments during the cooking cycle, simply use the up or down arrows next to the temperature or time icons.

NOTES:

- The unit will pause the cooking program if the oven door is opened during mid-cycle. The cooking cycle will resume once the oven door is closed.
- Press the POWER/START button at any time during the cooking process to cancel the cooking program. The unit will shut down and enter standby mode.
- Cooking time of a whole roasted chicken may vary depending on weight. Use a meat thermometer to check the internal temperature as per the chart on page 17.
- The Dehydrate setting has longer time and temp ranges.

SET UP AND USING AIR FRYER OVEN

BEFORE FIRST USE

1. Unbox the Unit and place on a countertop or flat surface away from any water source and near a polarized outlet. Before plugging in the Unit, remove accessories from the Internal Heating Compartment. Unwrap accessories.
2. Rinse the accessories with warm water and dry thoroughly. Place the Drip Pan at the bottom of the Internal Heating Compartment and close the oven door.
3. Plug in the Unit. Press the POWER/START button and follow the steps below:
 - a. Press the \wedge and \vee arrows next to the TEMP icon and set to 350°F
 - b. Press the \wedge and \vee arrows next to the TIME icon and set to 5 minutes
4. Press the POWER/START button again to begin heating.
5. This process will burn off any remaining residue left from the manufacturer. There may be a slight burning smell but, will dissipate after a few minutes.
6. Your new GoWISEUSA Air Fryer Oven is now ready for use!

REMOVABLE OVEN DOOR

The oven door can be removed for easy cleaning. **DO NOT** put the door in the dishwasher, as water may seep into the dual pane glass. Instead use a sponge or cloth with a dash of dish soap to remove grease and mess. Gently rinse with warm water and dry with a soft cloth.

To remove the door, lift it to a 45 degree angle while gently pulling towards you until it slides out. Clean both sides of the oven door with warm, soapy water and a damp cloth. **To reattach the door**, insert it at a 45 degree angle and pull door down lightly to ensure it's locked back into place.

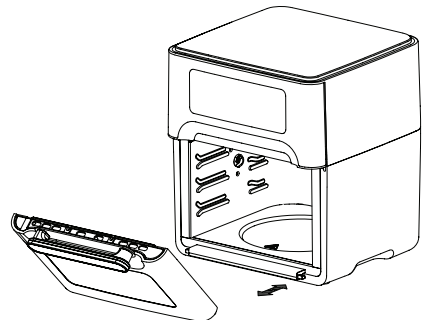
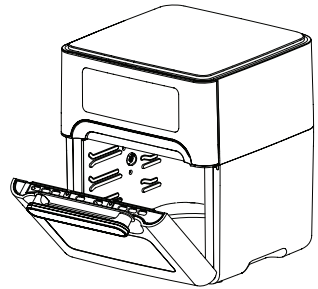

SET UP AND USING AIR FRYER OVEN

USING YOUR ACCESSORIES

Drip Pan

The drip pan should always be kept in the unit when cooking for easy cleanup. To use, simply slide the pan in the bottom of the Internal Heating Compartment and cook. The surface is an FDA-approved non-stick material. Be sure to use a non-abrasive sponge to clean.

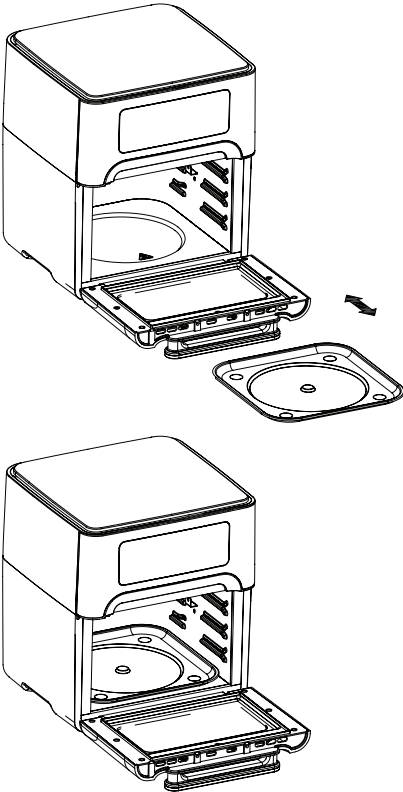

Mesh Trays

The mesh trays are perfect for dehydrating foods, but they are also great for cooking snacks, air frying chicken wings, reheating pizza and more. You can also hold baking pans at the correct distance from the heating element if you place it on a mesh tray in one of the 3 tray levels.

Mesh Basket

The mesh basket is perfect for roasting family-sized portions of veggies, chicken wings, and more. Use it as a third mesh tray to air fry crispy snacks, or add an extra layer of fruit to dehydrate.

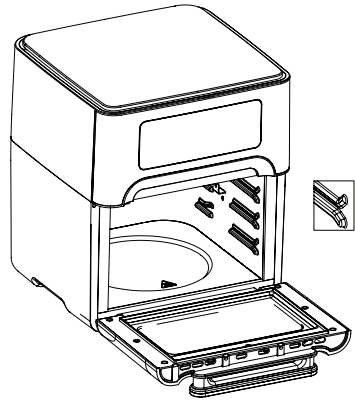

SET UP AND USING AIR FRYER OVEN

USING YOUR ACCESSORIES

Rotisserie Skewers: Use for cooking Kebabs.

Attaching Rotisserie Rod and Skewer Racks

1. Place the two Skewer Racks at each end of the Rotisserie Rod. Make sure thumb bolts are on the outer side of the Rotisserie Rod.
2. Slightly tighten the thumb bolts. Do not over tighten as you may need to adjust the tightness after inserting Skewers.
3. Carefully poke Skewers through food.

Rotisserie Skewer Assembly

4. Slide a Skewer into an open slot on the edge of the Skewer Rack with the clip facing toward the Rotisserie Rod.
5. Guide the sharp end of the Skewer through the hole on the opposite Skewer Rack and push the clip through the hole near the slot until the Skewer is secure.
6. Repeat steps 3-5 in a uniform manner around the Skewer Rack. Make sure Skewers are evenly spaced.
7. Tighten thumb bolts to make sure they are securely in place.
8. Use caution when inserting Rotisserie Skewers into the Unit to avoid being poked by the Skewer tips.
9. Open the oven door. Insert the long end of the Rotisserie Rod into the Rotisserie Socket first then, set the opposite end into the Rotisserie slot. Do not force the rod into the socket; rotate until the rod slips in easily.

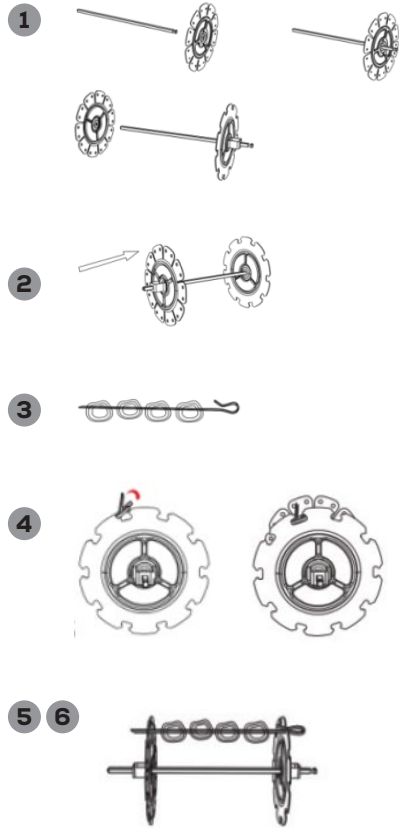

SET UP AND USING AIR FRYER OVEN

USING YOUR ACCESSORIES

Rotisserie Cage

Great for fries, roasted nuts, and other snacks. Fill the basket and use the rotisserie tong to place the basket into the unit.

How to use: Open the rotisserie cage door and add your ingredients. Close the cage door and insert into the oven using the rotisserie tong.

NOTE: Be sure to use oven mitts when removing the rotisserie cage after cooking.

Rotisserie Rod & Forks

Make your own rotisserie chicken, Cornish game hen, roasted pork loin and more using the rotisserie rod and forks. Keep in mind the maximum weight capacity for the rotisserie is **5 pounds**. When cooking a whole chicken or hen, you may need to truss it first. Instructions for trussing a chicken can be found on page 18 of this manual.

How to use: Force the rotisserie rod lengthwise through the center of the meat. Slide forks onto the rod from either end and into the meat. Lock in place by tightening the thumb screws. Use the rotisserie tong to place the rod into the rotisserie position in the heating compartment.

NOTE: Make sure the roast or chicken is not too large and rotates freely within the unit.

Removing Rotisserie Rod, Rotisserie Skewers, and Rotisserie Cage from Unit

1. Open the oven door.
2. While wearing oven mitts on both hands and using the Rotisserie Tong, hook the bottom left and right sides of the Rotisserie Rod, in the gaps of the rod and carefully lift the rod out of the resting slot on the right side of the oven – carefully pull the rod out of the Rotisserie socket and remove from the oven.

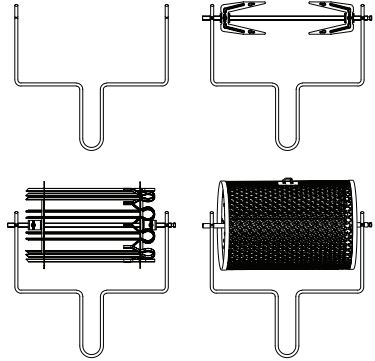

NOTE: Contents will be hot and can easily burn – **USE CAUTION**. Hold a catch tray or plate under the Rotisserie contents to prevent scalding meat juices or oils from falling on skin.

SET UP AND USING AIR FRYER OVEN

USING YOUR AIR FRYER OVEN

NOTES:

- The GoWISE USA Air Fryer Oven **Select** will only begin heating once the oven door is completely closed.
- The oven door can be opened during the cooking process – the Unit will stop heating and the fan will stop running automatically until the door is closed again. When opened the display will also shut off, but once the door is closed, it will resume.

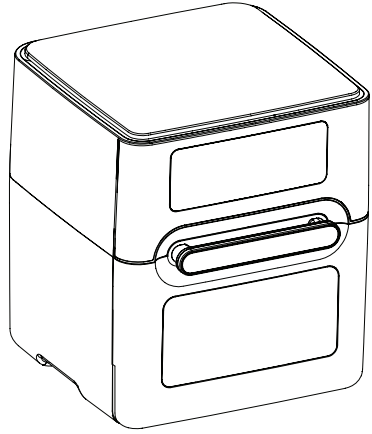

CAUTION!

- Contents and cooking accessories will be extremely hot after every use. To prevent personal injury, always use oven mitts to remove contents and always wait until the Unit has cooled sufficiently before touching or cleaning any area of the Internal Heating Compartment of the Air Fryer Oven.
- Never use a cooking vessel filled with cooking oil or any other liquid with this Unit! Fire Hazard or personal injury could result.

COOKING GUIDE

INTERNAL TEMPERATURE CHART

*This chart should be used to check the temperature of cooked meats. Always review USDA Food Safety Standards.

Food	Type	Internal Temperature
Beef + Veal	Ground	160°F (70°C)
	Steaks, Roasts: medium	160°F (70°C)
	Steaks, Roasts: rare	145°F (63°C)
Chicken + Turkey	Breasts	165°F (75°C)
	Ground, Stuffed	165°F (75°C)
	Whole bird, legs, thighs, wings	165°F (75°C)
Fish + Shellfish	Any type	145°F (63°C)
Lamb	Ground	160°F (70°C)
	Steaks, Roasts: medium	160°F (70°C)
	Steaks, Roast: rare	145°F (63°C)
Pork	Chops, Ground, Ribs, Roasts Fully cooked Ham	160°F (70°C) 140°F (60°C)

TIPS

- Cooking times may vary based on the quantity and thickness of the ingredients.
- Try flipping ingredients mid-way through the cooking process for an even, crispy texture.
- Adding a minimal amount of oil to fresh potatoes will give it a crispier result.
- Avoid cooking extremely oily ingredients in the air fryer.
- Anything that can be prepared in a traditional oven can also be cooked in the air fryer.
- Pre-made or store bought dough requires a shorter cooking time than homemade dough.
- When baking a cake, quiche or other recipes using a filling, cook in a tin or oven safe pan.
- When using the rotisserie, make sure the contents are secure and do not flop loosely.
- Do not rotisserie foods that are too heavy! 5 lbs max.
- For the best rotisserie experience, always truss meats, chicken, and roasts with butcher's twine.

TRUSSING A WHOLE CHICKEN

1. Finding the right size chicken
– be careful not use a chicken exceeding the 5 lbs max.
2. After preparing, i.e., seasoning the chicken, truss the chicken using butcher's twine.
 - a. Place the chicken on its back with the legs facing toward you.
 - b. Slide a piece of twine under the back of the chicken between the wings and the thighs.
 - c. Pull both ends of the twine up under the chicken's armpits, then pull them over the wings.
 - d. Cross the string around the top of the breast, making sure the skin is secure.
 - e. Bring the ends of the twine back toward you, running them along the sides of the breast above the wings and thighs.

a



b



c



d



e



TRUSSING A WHOLE CHICKEN

- f. Cross the ends of the twine, pulling tightly up and under the crown of the bird.
- g. Loop the ends of the string under the legs, then over the top of the legs. Cross and tighten. The thighs should pop up a little.
- h. Flip the bird onto its belly and finish by tying the strings in a knot around the tail. Snip off the ends.

f

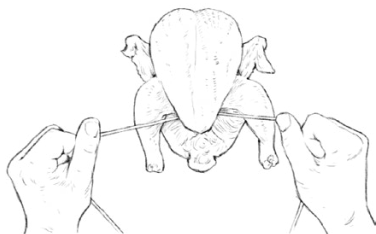

g

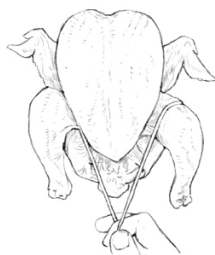

h



ROTISSERIE ROAST A WHOLE CHICKEN

Using the Rotisserie Rod to Roast a Whole Chicken

1. After the chicken is trussed, carefully maneuver the Rotisserie Rod through the chicken from the neck to the legs.
2. Slide the Rotisserie Forks on both sides of the Rotisserie Rod piercing the chicken; making sure to secure the chicken in place.
3. Using the Thumb Bolts, lightly tighten the Rotisserie Forks into place – Do not over tighten as removing Rotisserie Forks as removing Rotisserie Forks may become difficult after cooking.
4. Open the oven door. Insert the long end of the Rotisserie Rod into the Rotisserie Socket first then, set the opposite end into the Rotisserie slot. Do not force the rod into the socket, rotate until the rod slips in easily.
5. Turn the Unit on by pressing the POWER/START button and select the Roast Chicken preset.
6. Press ROTISSERIE button on the Digital Display to engage the rotation functionality of the oven.
7. The default cooking temperature and time for Rotisserie is 400°F for 30 min – if the chicken is not golden brown and crispy and the internal temperature is not 165°F, repeat the cooking cycle.
8. When the chicken is done cooking with the internal temperature of 165°F, remove the chicken using the Rotisserie Tong.

 - a. Open the oven door.
 - b. While using oven mitts on both hands and using the Rotisserie Tong, hook the bottom left and right sides of the Rotisserie Rod, in the gaps of the rod and carefully lift the rod out of the resting slot on the left side of the oven – carefully pull the rod out of the Rotisserie socket and remove from the oven.

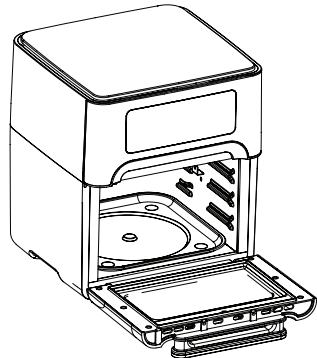
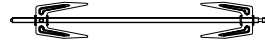

NOTE: Contents will be hot and can easily burn – use caution not to let scalding meat juices or oils from falling on the skin by holding a catch tray or plate under the Rotisserie contents.

ERROR CODES & TROUBLESHOOTING

ERROR CODE	ISSUE
E1	NTC short circuit
E2	NTC open circuit
E3	Overheating (see "Overheating Protection" on page 7)

If your GoWISE USA Air Fryer Oven displays any of these Error Codes, please contact Customer Care Team.

855-233-9199

support@gowiseusa.com

Live Chat at gowiseusa.com

M-F 8:30am - 4:00pm MST

TROUBLESHOOTING

- **Why won't my air fryer oven turn on?**

First, make sure the air fryer oven is plugged in and the oven door is closed. You can also try using different outlets if it's still not turning on. If none of these solve the problem, please contact our Customer Support.
- **My food is not cooked all the way / My food doesn't seem crispy enough**
 - Your oven may be overfilled with ingredients. Cook in smaller batches for more even cooking.
 - You may have the temperature set too low. Increase the temp. and continue cooking (see temperature recommendations in your manual).
 - For a crispier effect, brush with oil before air frying.
 - Try flipping or rotating your food over midway through the cooking cycle. This will ensure even cooking.
- **White smoke is coming out of my air fryer oven. Should I be worried?**

It's normal for white smoke to appear when prepping greasy ingredients. When frying greasy ingredients, a large amount of oil will leak into the pan. The oil produces white smoke and the oven may heat up more than usual. This does not affect the appliance or end food result. Be sure to clean your oven properly after each use to prevent it from smoking during the next use. It helps to wipe down the heating element as well.
- **How do I stop the cooking cycle on my air fryer oven?**

Press the POWER/START button to completely stop your cooking cycle.

NOTE: Opening the oven door pauses the cooking cycle.

WARRANTY

GoWISE USA warrants all products against defects in materials and workmanship for **one (1) year** effective from the date of purchase.

GoWISE USA will replace any products that are found to be defective due to manufacturer flaws based on eligibility. Refunds issued by GoWISE USA must be purchased directly from GoWISE USA and are only available to the original purchaser within the first 30 days. We do not issue refunds for items bought by thirdparty retailers.

This warranty extends only to personal use and does not extend to products that has been used for commercial, rental or any other use this product was not intended for. There are no warranties other than the warranties expressly set forth with each product.

This warranty is non-transferrable. GoWISE USA is not responsible in any way for any damages, losses, or inconveniences caused by equipment failure by user negligence, abuse, or use noncompliant with the user manual or any additional safety, use, or warnings included in the product packaging and manual.

This warranty only covers purchases within the 48 contiguous States of United States of America. For purchases made outside the 48 contiguous states, such as, AK, HI, PR or Canada; upon receipt of a proven defect by video or picture, we will replace the unit under the 1-year warranty, however the replacement will only ship to a freight forwarder or an address within the 48 contiguous United States. The consumer is responsible for arranging shipment outside of the 48 contiguous states.

GoWISE USA assumes no liability for damage caused using this product other than for its intended use or as instructed in the user manual. Some states do not allow this exclusion or limitation of incidental or consequential losses, so the foregoing disclaimer may not apply to you. This warranty gives you specific legal rights and you may also have other rights which may vary from state to state.

ALL EXPRESSED AND IMPLIED WARRANTIES INCLUDING THE WARRANTY OF MERCHANTABILITY, ARE LIMITED TO THE PERIOD OF THE LIMITED WARRANTY.

NOTE: General Warranty excludes refurbished / auction items.

WARRANTY

Additional 60-Days Warranty

You can extend your 1-year warranty by an additional 60 days. Log onto [www.gowiseproducts.com/apps/ product-registration](http://www.gowiseproducts.com/apps/product-registration) and register your product within the first 14 days of your purchase for the extended warranty.

DEFECTIVE PRODUCTS & RETURNS

If your product is defective within the 1-year warranty period, please email our Customer Care Team at support@gowiseusa.com. To expedite your issue, please provide at least 3 of the 4 items below:

1. Copy of the invoice, order information, or gift receipt showing the date of purchase
2. Serial number, usually found on a sticker located on the bottom on back of the unit
3. Picture or video of the issue or defect that you are experiencing
4. Shipping address information

Authorized Retailers:

Amazon

GoWISE USA

WayFair

Houzz

Home Depot

etailz

MorningSave.com

Bed Bath & Beyond

Jet.com

Walmart.com

Macy's

GoWISEUSA®

WWW.GOWISEUSA.COM

855-233-9199

support@gowiseusa.com

Live Chat at gowiseusa.com

M-F 8:30am - 4:00pm MST

- To ensure the correct use of this appliance, read these instructions carefully and thoroughly.
- Please keep this manual for future reference.
- Thank you for purchasing this GoWISE USA Air Fryer Oven.

USE PROMO CODE: **LIVewiseraF**

10% OFF

YOUR NEXT **GoWISEUSA®** PURCHASE

