

MILLENNIUM DXL2

OPERATION GUIDE

PANAVISION.COM

PANAVISION MILLENNIUM DXL2

TABLE OF CONTENTS

Table of Contents	2	Audio During Playback	113
Compliance Statements	4	Timecode, Genlock, Multi-Camera Setup	114
Safety Instructions	6	Timecode	114
Product Introduction	7	Genlock	116
R3D File Format and REDCODE	7	Master/Slave Operation	118
Post Production	7	Set Up Stereo/3D Configuration	122
Camera System Components	8	Camera Array	123
Camera Body	8	Compatible Timecode Devices	123
Media	13	Compatible Genlock Devices	124
DXL Hot Swap Module	14	Upgrade Camera Firmware	125
FIZ Module	21	Verify Current Camera Firmware	125
Lens Mount	21	Upgrade Camera Firmware	125
Additional Components	21	Camera System Maintenance	126
Basic Operations	22	Camera Body and Accessory Exterior Surfaces ..	126
Power Operations	22	Water Damage	126
Set Up the DXL Hot Swap Module	25	Troubleshoot Your Camera	127
Record	27	General Troubleshooting	127
Basic Menus and User Interface	28	Error Messages	131
GUI Menu Introduction	28	APPENDIX A: Technical Specifications	132
Home Page	29	Panavision Millennium DXL2	132
User Page	31	APPENDIX B: Mechanical Drawings	133
Monitor Page	33	Front View	133
Audio Page	34	Back View	134
Menus Only Accessible Via Home and User Pages	35	Side View (Right)	135
Detailed Menus	42	Side View (Left)	136
Project Settings	42	Top View	137
Monitoring	57	APPENDIX C: Input/Output Connectors	138
Media Menu	65	USB Power	141
Look Menu	67	DC-IN	141
User Presets Menu	73	6G/3G HD-SDI	142
Network Menu	80	3G HD-SDI	143
Maintenance	86	RETURN	143
Playback	104	14V Aux Power Out	144
Audio System	106	AUX Power Out	145
Audio Overview	106	TIMECODE	146
Control	107	GENLOCK	146
Monitor Mix	110	GIG-E	147
Audio Output	112	LCD/EVF Ports	147
Audio Meter (VU Meter)	112	14V Aux Power Out	147
		24V Aux Power Out	148

PANAVISION MILLENNIUM DXL2

Lens Information	149
Lens Mount	149
Default Key Functions	150
Default Keys	150
Menu Map	152

PANAVISION MILLENNIUM DXL2

COMPLIANCE STATEMENTS

INDUSTRIAL CANADA EMISSION COMPLIANCE STATEMENTS

This device complies with Industry Canada license-exempt RSS standards RSS 139 and RSS 210. Operation is subject to the following two conditions: (1) this device may not cause interference, and (2) this device must accept any interference, including interference that may cause undesired operation of the device.

This Class B digital apparatus complies with Canadian ICES-003.

Le présent appareil est conforme aux CNR d'Industrie Canada applicables aux appareils radio exempts de licence. L'exploitation est autorisée aux deux conditions suivantes : (1) l'appareil ne doit pas produire de brouillage, et (2) l'utilisateur de l'appareil doit accepter tout brouillage radioélectrique subi, même si le brouillage est susceptible d'en compromettre le fonctionnement. Cet appareil numérique de la classe B est conforme à la norme NMB-003 du Canada.

FEDERAL COMMUNICATIONS COMMISSION (FCC) STATEMENTS



This equipment has been tested and found to comply with the limits for a Class B digital device, pursuant to part 15 of the FCC Rules. These limits are designed to provide reasonable protection against harmful interference in a residential installation. This equipment generates, uses and can radiate radio frequency energy and, if not installed and used in accordance with the instructions, may cause harmful interference to radio communications. However, there is no guarantee that interference will not occur in a particular installation. If this equipment does cause harmful interference to radio or television reception, which can be determined by turning the equipment off and on, the user is encouraged to try to correct the interference by one or more of the following measures:

- ▶ Reorient or relocate the receiving antenna.
- ▶ Increase the separation between the equipment and receiver.
- ▶ Connect the equipment into an outlet on a circuit different from that to which the receiver is connected.
- ▶ Consult the dealer or an experienced radio/TV technician for help.

In order to maintain compliance with FCC regulations, shielded cables must be used with this equipment. Operation with non-approved equipment or unshielded cables is likely to result in interference to radio and TV reception. The user is cautioned that changes and modifications made to the equipment without the approval of manufacturer could void the users authority to operate this equipment.

NOTE: This device complies with Part 15 of the FCC Rules.

Operations subjected to the following two conditions (1) this device may not cause harmful interference, and (2) this device must accept any interference received, including that may cause undesirable interference.



CAUTION: Exposure to Radio Frequency Radiation.

The device shall be used in such a manner that the potential for human contact is minimized.

This equipment complies with FCC radiation exposure limits set forth for an uncontrolled environment. This equipment should be installed and operated with a minimum distance of 20 cm between the radiator and your body.



CAUTION: Regulations of the FCC and FAA prohibit airborne operation of radio-frequency wireless devices because their signals could interfere with critical aircraft instruments.



CAUTION: If the device is changed or modified without permission, the user may void his or her authority to operate the equipment.

AUSTRALIA AND NEW ZEALAND STATEMENTS

Panavision declares that the radio equipment described in this document comply with the following international standards.

- ▶ IEC 60065 – Product Safety
- ▶ ETSI EN 300 328 – Technical requirement for radio equipment

Panavision declares digital devices described in this document comply with the following Australian and New Zealand standards.

- ▶ AS/NZS CISPR 22 – Electromagnetic Interference
- ▶ AS/NZS 61000.3.2 – Power Line Harmonics
- ▶ AS/NZS 61000.3.3 – Power Line Flicker

JAPAN STATEMENTS



This is a Class B product based on the standard of the Voluntary Control Council for Interference (VCCI) for information technology equipment. If this equipment is used near a radio or television receiver in a domestic environment, it may cause radio interference. Install and use the equipment according to the

instruction manual.

この装置は、情報処理装置等電波障害自主規制協議会 (VCCI) の基準に基づくクラス B 情報技術装置です。この装置は家庭環境で使用することを目的としていますが、ラジオやテレビジョン受信機に近接して使用されると、受信障害を引き起こすことがあります。取扱説明書に従って正しい取り扱いをしてください。

PANAVISION MILLENNIUM DXL2

EUROPEAN UNION COMPLIANCE STATEMENTS



Panavision declares that the radio equipment described in this document comply with the R&TTE Directive (1999/5/EC) issued by the Commission of the European Community.

Compliance with this directive implies conformity to the following European Norms (in brackets are the equivalent international standards).

- ▶ EN 60065 (IEC 60065) – Product Safety
- ▶ ETSI EN 300 328 Technical requirement for radio equipment
- ▶ ETSI EN 301 489 General EMC requirements for radio equipment.

INFORMATION

Products with the CE marking comply with the EMC Directive (2004/108/EC) and the Low Voltage Directive (2006/95/EC) issued by the Commission of the European Community. Compliance with these directives implies conformity to the following European Product Family Standards.

- ▶ EN 55022 (CISPR 22) – Electromagnetic Interference
- ▶ EN 55024-1 (CISPR 24) – Electromagnetic Immunity
- ▶ EN 61000-3-2 (IEC610000-3-2) – Power Line Harmonics
- ▶ EN 61000-3-3 (IEC610000) – Power Line Flicker
- ▶ EN 60065 (IEC60065) – Product Safety

WASTE ELECTRICAL AND ELECTRONIC EQUIPMENT (WEEE)

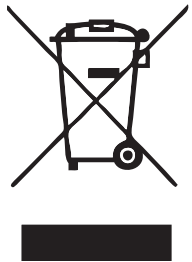

The Waste Electrical and Electronic Equipment (WEEE) mark applies only to countries within the European Union (EU) and Norway. This symbol on the product and accompanying documents means that used electrical and electronic products should not be mixed with general household waste. For proper treatment, recovery and recycling, please take this product to designated collection points where it will be accepted free of charge. Alternatively, in some countries you may be able to return your products to your local retailer upon purchase

of an equivalent new product.

Disposing of this product correctly will help save valuable resources and prevent any potential negative effects on human health and the environment, which could otherwise arise from inappropriate waste handling. Please contact your local authority for further details of your nearest designated collection point. Penalties may be applicable for incorrect disposal of this waste, in accordance with your national legislation.

For business users in the European Union, if you wish to discard electrical and electronic equipment, please contact your dealer or supplier for further information.

USAGE RESTRICTIONS FOR PRODUCTS THAT INCORPORATE RED COMMAND PROTOCOL

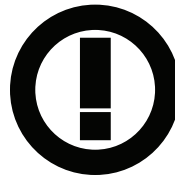

Products that fall into this category are denoted by inclusion of the Class 2 identifier symbol (exclamation mark in a circle) accompanying the CE Mark on the products regulatory label, example to the left.

FRANCE

Usage Restrictions - Geographic Area Where Restriction Applies : France

For mainland France

- ▶ 2.400 - 2.4835 GHz (Channels 1-16) authorized for indoor use
- ▶ 2.400 - 2.454 GHz (Channels 1-10) authorized for outdoor use

Restrictions d'utilisation - Zone géographique où les restrictions s'appliquent : France

Pour la France métropolitaine

- ▶ 2.400 - 2.4835 GHz (Canaux 1 à 16) autorisé en usage intérieur
- ▶ 2.400 - 2.454 GHz (canaux 1 à 10) autorisé en usage extérieur

NORWAY

This subsection does not apply for the geographical area within a radius of 20 km from the centre of Ny-Ålesund

Dette gjelder ikke for det geografiske området innenfor en radius av 20 km fra sentrum av Ny-Ålesund

PANAVISION MILLENNIUM DXL2

SAFETY INSTRUCTIONS

- ▶ DO NOT use the camera or accessories near water. Avoid exposing your camera to moisture. The unit is not waterproof, so contact with water could cause permanent damage to the unit as well as electric shock and serious injury to the user. DO NOT use the camera in the rain or under other conditions with high moisture without appropriate protection, and immediately remove power source if camera or accessories are exposed to moisture.



WARNING: To reduce the risk of fire or electric shock, do not expose the camera to rain or moisture.

- ▶ DO NOT expose the camera to laser beams, as laser beams may damage the sensor.
- ▶ DO NOT expose your camera to excessive vibration or impact (shock). Be careful not to drop your camera. Internal mechanisms may be damaged by severe shock. Mechanical alignment of optical elements may be affected by excessive vibration.
- ▶ ELECTROMAGNETIC INTERFERENCE: The use of devices using radio or other communication waves may result in the malfunction or interference with the unit and/or with audio and video signals.
- ▶ Clean only using a dry cloth. When cleaning your camera, remember that it is not waterproof and moisture can damage electronic circuitry. DO NOT rinse or immerse any element of the camera, lens or other accessory, keep them dry at all times. DO NOT use soaps, detergents, ammonia, alkaline cleaners, and abrasive cleaning compounds or solvents. These substances may damage lens coatings and electronic circuitry.
- ▶ Maintain sufficient ventilation—DO NOT block any ventilation openings or obstruct cooling fan airflow.



CAUTION: Proper camera ventilation requires a minimum 0.5" (1.25 cm) clearance between the camera ventilation openings and external surfaces. Verify that objects that can block the fan intake and exhaust ports do not impede airflow. Failure to permit adequate airflow may result in overheating of the camera, degraded operation and in extreme situations, damage to the camera.

- ▶ DO NOT operate or store near any heat sources such as radiators, heat registers, stoves, or any other apparatus that produce heat. Store in a protected, level and ventilated place. Avoid exposure to temperature extremes, damp, severe vibration, strong magnetic fields, direct sunlight or local heat sources during storage. Remove any batteries from the camera before storage. Recommended storage and usage temperatures for your camera, lenses and other accessories are:
 - ▶ Operating range: 0°C to 40°C (32°F to 104°F)
 - ▶ Storage range: -20°C to 50°C (-4°F to 122°F)
- ▶ Protect all power cords from being pinched, walked on or driven over by a vehicle. Replace any power cords suspected of sustaining damage due to crushing or other forms physical damage.

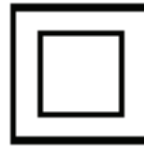

Products marked with this symbol are class 2 devices. These devices are not provided with a grounding type plug.

- ▶ Lithium-ion batteries may be subject to special handling requirements pursuant to federal and local laws. Please refer to specific shipping instructions included with your battery regarding proper transport of your battery. Do not handle your battery if it is damaged or leaking. Disposal of batteries must be in accordance with local environmental regulations. For example, California law requires that all rechargeable batteries must be recycled by an authorized recycle center. Storing batteries fully charged or in high temperature conditions may permanently reduce the life of the battery. Available battery capacity may also be temporarily lessened after storage in low temperature conditions.



WARNING: DO NOT expose the battery to excessive heat.



INDOOR USE ONLY: Products marked with this symbol are designed for use indoors only.

PANAVISION MILLENNIUM DXL2

PRODUCT INTRODUCTION

The Panavision Millennium DXL2 is a revolutionary digital camera from Panavision. The large-format sensor captures images at up to 8K. The camera incorporates the unique Light Iron Color 2 color science, which is compatible with all popular gamuts and transfer curves.



Figure: Panavision Millennium DXL2

R3D FILE FORMAT AND REDCODE

All videos and frames are recorded to the R3D[®] file format. The R3D file format was developed by RED to provide an efficient and manageable RAW video data format that promotes advanced post production editing capabilities. In the R3D file format, the digital image received from the sensor is formatted as a pixel-defect corrected (but in all other aspects unprocessed) 16-bit per pixel RAW data frame. Each RAW frame, or sequence of RAW frames in a clip, is compressed using a proprietary wavelet based REDCODE[®] RAW compression, then stored to a Panavision MINI-MAG.

RAW data is recorded independently of any RGB domain color processing such as ISO, White Balance, or other RGB color space settings. Instead, color parameters are saved as reference metadata; that is, color is not burned into the recorded RAW data. This recording technique promotes flexibility in RGB color processing, which can be deferred to post production or adjusted in the field, without affecting the recorded RAW data image quality or dynamic range.

REDCODE is a visually lossless, wavelet-based compression codec that reduces R3D RAW files into a manageable size, allowing longer recording times on media. The ability to compress RAW data is one of the significant technologies that RED has brought to the industry.

POST PRODUCTION

DXL2 R3D files are able to be processed in any application that utilizes the RED SDK. 3D LUT transforms to various popular color spaces and gammas are available for download. For further information and on post production workflow please visit the Panavision website.

CAMERA SYSTEM COMPONENTS

NOTE: Availability of components listed in this chapter is subject to change at any time.

CAMERA BODY

For more information on connectors, go to ["Input/Output Connectors"](#) on page 138.



Figure: Panavision Millennium DXL2 Body

PANAVISION MILLENNIUM DXL2

CAMERA BODY CONTROLS

RIGHT SIDE (ASSISTANT SIDE) CONTROLS

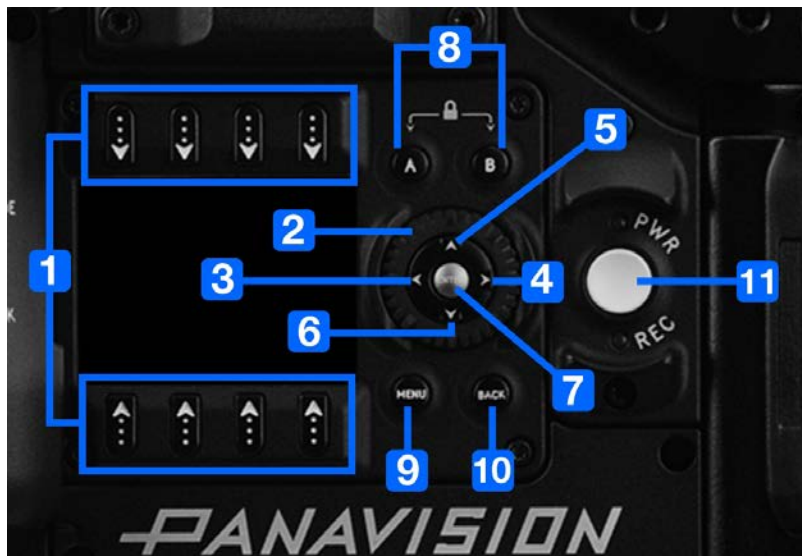

Figure: Panavision Millennium DXL2 Controls, Right Side (Assistant Side)

#	CONTROL	DESCRIPTION
1	Selection keys	Select an option or open a shortcut (when available)
2	Navigation Wheel	Move cursor up/down
3	Nav West	Move cursor left Return to the last menu
4	Nav East	Move cursor right Select menu
5	Nav North	Move cursor up
6	Nav South	Move cursor down
7	Nav Enter	Navigation: Select
8	Assistant A Assistant B	Programmable keys Assistant A + Assistant B: Toggle lock/unlock all keys on Assistant Side
9	Menu	Access/Exit menus
10	Back	Return to the last menu
11	PWR/REC Key	Fully press and hold the PWR/REC key for two (2) seconds to turn on/off. When the camera is on, fully press and then release the PWR/REC key to toggle record start/stop.

For more information, go to ["Default Key Functions"](#) on page 150.

PANAVISION MILLENNIUM DXL2

LEFT SIDE (OPERATOR SIDE) CONTROLS

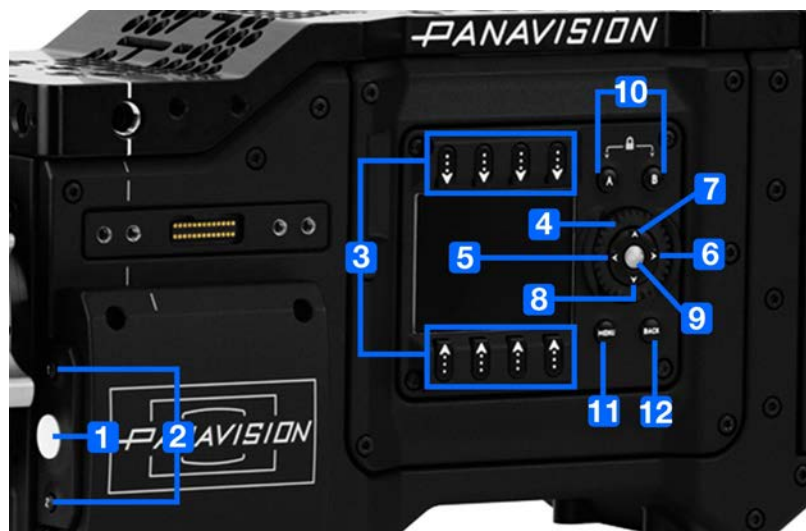

Figure: Panavision Millennium DXL2 Controls, Left Side (Operator Side)

#	CONTROL	DESCRIPTION
1	REC button	Programmable key Full Press: Record Toggle
2	User Key 1 User Key 2	Programmable keys User Key 1 + 2 Press: Eject Media
3	Selection keys	Select an option or open a shortcut (when available)
4	Navigation Wheel	Move cursor up/down
5	Nav West	Move cursor left Return to the last menu
6	Nav East	Move cursor right Select menu
7	Nav North	Move cursor up
8	Nav South	Move cursor down
9	Nav Enter	Navigation: Select
10	Operator A Operator B	Programmable keys Operator A + Operator B: Toggle lock/unlock all keys on Operator Side
11	Menu	Access/Exit menus
12	Back	Return to the last menu

PANAVISION MILLENNIUM DXL2

CAMERA BODY LEDS

RIGHT SIDE (ASSISTANT SIDE) LEDS



Figure: Panavision Millennium DXL2 LEDs, Right Side (Assistant Side)

NOTE: When the camera is powered only by battery and not AC power, the Power Status LED (PWR) does not turn on. You can press the button on the battery to check the battery charge level.

PANAVISION MILLENNIUM DXL2

#	LED	COLOR/FLASHING	DESCRIPTION
1	DC-IN	Off	No DC power present
		Green	DC power present
2	Power Status LED (PWR)	Off	Camera off ¹
		Green	Camera on
		Amber flashing	Camera on; 5 to 10 min of battery time available
		Amber	Camera booting
		Red flashing	Camera on; < 5 min of battery time available
		Red	Camera shutting down
3	Record Status LED (REC)	Off	No media present
		Green	Ready to record
		Amber	Finalizing
		Red flashing (slow)	Media mounted with > 5% and ≤ 10% of media space available
		Red flashing (fast)	Media mounted with ≤ 5% of media space available
		Red	Recording
N/A	Power Status LED (PWR) and Record Status LED (REC)	Both green flashing	Firmware update in progress
		Both red flashing	Firmware update error

1. To prevent battery drain, the PWR LED does not illuminate when the camera is off and a power source is present.

PANAVISION MILLENNIUM DXL2

LEFT SIDE (OPERATOR SIDE) LEDS



Figure: Panavision Millennium DXL2 LEDs, Left Side (Operator Side)

#	LED	COLOR/FLASHING	DESCRIPTION
1	Media Status LED (Back of media bay)	Off	No media mounted
		Green	Preview; media mounted with > 10% of media space available
		Amber	Record finalizing or playback mode
		Amber flashing (slow)	Formatting media
		Red flashing (slow)	Media mounted with > 5% and ≤ 10% of media space available
		Red flashing (fast)	Media mounted with ≤ 5% of media space available
		Red	Recording; media mounted with > 10% of media space available
2	Record Status LED ¹	Off	Not recording, or media not mounted
		Red	Recording

1. For more information on how to enable/disable this LED, go to "Indicator" on page 99. If media is not mounted, this LED is off.

MEDIA

The following SSDs are compatible with the Panavision Millennium DXL2:

ITEM	PV PRODUCT TYPE
Panavision MINI-MAG 512GB	DXLM512
Panavision MINI-MAG 1TB	DXLM1

PANAVISION MILLENNIUM DXL2

DXL HOT SWAP MODULE



Figure: DXL Hot Swap Module

The DXL Hot Swap Module (Product Code: DXLHS) mounts to the rear of the Panavision Millennium DXL2 (using a Panavision Adaptor Plate) and supports Anton Bauer Gold Mount batteries. The DXL Hot Swap Module offers multiple power out ports for accessories and an additional PWR IN (Studio In) port. The power out ports on the DXL Hot Swap Module provide a combined 14V power out (combined 10 A max current) when the module is receiving power.

The battery plate slides up and down the module, and can be locked into any position on the slide. The highest position is ideal for studio shoots, and the lowest position is ideal for hand-held shoots.

PANAVISION MILLENNIUM DXL2

DXL HOT SWAP MODULE CONNECTIONS



Figure: DXL Hot Swap Module

#	CONNECTOR	CONNECTOR TYPE	CONNECTOR FUNCTION	DETAILS
1	P-Tap	P-Tap	Power out	"P-Tap Connector" on the next page
2	14V	2-pin 0B LEMO	Power out; protected by a spring-loaded cover	"14V Aux Power Out" on the next page
3	14V, 5A	2-pin 0B LEMO	Power out	"14V, 5A Aux Power Out" on page 17
4	24V	Fischer 3-pin 102	Power out	"24V Aux Power Out" on page 17
5	USB PWR	USB 2.0, Type A (power only)	USB power out	"USB PWR" on page 17
6	PWR IN	4-pin 2B LEMO	Power in (studio in)	"PWR IN (Studio In)" on page 18

PANAVISION MILLENNIUM DXL2

P-TAP CONNECTOR

The DXL Hot Swap Module offers one (1) P-Tap connector that provides power (14V, 10A max) for camera accessories.

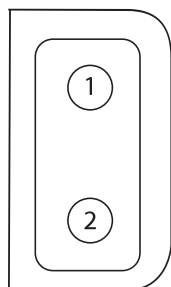

Figure: P-Tap Connector (Looking at Camera)

2-PIN P-TAP CONNECTOR			
PIN	SIGNAL	DESCRIPTION	DIRECTION
1	GROUND	Common ground	N/A
2	14V	14V	Out

14V AUX POWER OUT

The 2-pin 0B LEMO connector (LEMO EEG.0B.302.CLL) supplies unregulated (+) 11.5 to 17V DC battery pass-through power. The maximum sustained current draw is 3.0A.

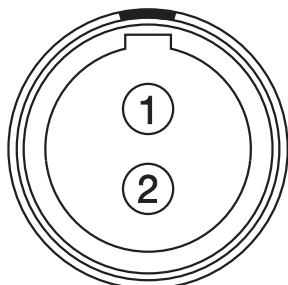

Figure: Front Face of Connector (Looking at the Camera)

LEMO EEG.0B.302.CLL CONNECTOR			
PIN	SIGNAL	DESCRIPTION	DIRECTION
1	GROUND	Common ground	N/A
2	+11.5 to +17V DC	+11.5 to 17V DC unregulated battery pass-through power	Out

NOTE: Mating connector is FGG.0B.302.CLAD.

PANAVISION MILLENNIUM DXL2

14V, 5A AUX POWER OUT

The 2-pin 0B LEMO connector (LEMO EEG.0B.302.CLL) supplies unregulated (+) 11.5 to 17V DC battery pass-through power. The maximum sustained current draw is 5.0A.

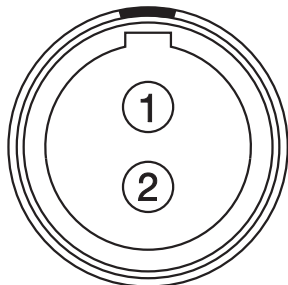

Figure: Front Face of Connector (Looking at the Camera)

LEMO EEG.0B.302.CLL CONNECTOR			
PIN	SIGNAL	DESCRIPTION	DIRECTION
1	GROUND	Common ground	N/A
2	+11.5 to +17V DC	+11.5 to 17V DC unregulated battery pass-through power	Out

NOTE: Mating connector is FGG.0B.302.CLAD.

24V AUX POWER OUT

The two (2) Fischer connectors (DG 102 A052-130) up convert from 12V to 24V.

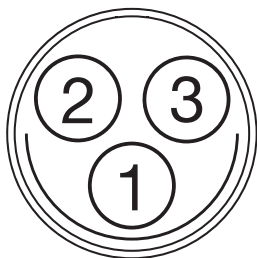

Figure: 24V Connector (Looking at the Camera)

FISCHER 3-PIN CONNECTOR			
PIN	SIGNAL	DESCRIPTION	DIRECTION
1	GROUND	Common ground	N/A
2	24V	24V	Out
3	Trigger	Active Low to start/stop record	In

USB PWR

The USB power-out connector supplies 5V of power. The maximum sustained current draw is 1.5A.

NOTE: The USB connector only offers power out, and does NOT support USB communication.

PANAVISION MILLENNIUM DXL2

PWR IN (STUDIO IN)

The 4-pin 2B LEMO connector (LEMO EGJ.2B.304.CLA) accepts DC input power from 11.5V DC to 17V DC.

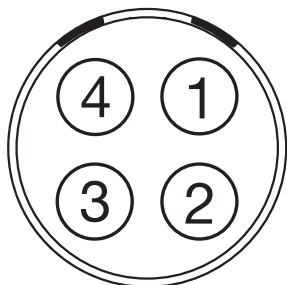

Figure: Front Face of the Connector (Looking at the Camera)

LEMO EGJ.2B.304.CLA CONNECTOR			
PIN	SIGNAL	DESCRIPTION	DIRECTION
1	14V	VBATT (11.5 TO 18V DC) @ 9A	In
2	Ground	Common ground	N/A
3	28V	VBATT (18 to 30V DC) @ 3A Exclusively powers attached accessories and lens control devices. Power from this pin does NOT power the camera.	In
4	Ground	Common ground	N/A

NOTE: Mating connectors are FGJ.2B.304.CLLD62Z and FGJ.2B.304.CLLD52.

PANAVISION MILLENNIUM DXL2

DXL HOT SWAP MODULE LEDS

To prevent battery drain, the LEDs on the DXL Hot Swap Module do not illuminate when the camera is off and a power source is present.



Figure: DXL Hot Swap Module

PANAVISION MILLENNIUM DXL2

#	LED	COLOR/FLASHING	DESCRIPTION
1	14V	Off	Module off
		Green	Port available
2	OB (on-board battery; at top of module)	Off	Camera is not powered via the on-board battery
		Amber	Camera is powered via the on-board battery
		Flashing	Battery power running low
3	Studio	Off	Camera is not powered via the PWR IN port
		Blue	Camera is powered via the PWR IN port
		Flashing	Voltage via the PWR IN port is low
4	14V 5A, 24V	Off	Module off
		Green	Port available
5	OB (on-board battery; at bottom of module)	Off	Battery is not present
		Green	Battery is present
6	PWR IN	Off	Camera is not powered via the PWR IN port
		Green	Camera is powered via the PWR IN port

1. To prevent battery drain, the PWR LED does not illuminate when the camera is off and a power source is present.



PANAVISION MILLENNIUM DXL2

FIZ MODULE



Figure: FIZ Module

The Panavision Millennium DXL2 features a modular FIZ (focus, iris, zoom) control system. The Panavision Millennium DXL2 initially ships with a native, non-radio FIZ module, the DXLM Module. Panavision also offers additional FIZ modules that are compatible with third-party systems, including:

- ▶ Panavision DXLMP Preston FIZ Module
- ▶ Panavision DXLMC cmotion Module (also compatible with Arri WCU-4 handset)

For more information on connectors for the DXLM Module, go to ["Input/Output Connectors" on page 138](#).

LENS MOUNT

The Panavision Millennium DXL2 features a built-in SP70 lens mount, which is compatible with Primo 70 Series lenses. The lens mount is also compatible with select adaptors that support other lens mounts.

ADDITIONAL COMPONENTS

The Panavision Millennium DXL2 is compatible with additional components including:

- ▶ Base plate
- ▶ Jumper block
- ▶ Third-party FIZ devices
- ▶ EFV and brackets
- ▶ Additional modules
- ▶ Cheese plate and handles

BASIC OPERATIONS

POWER OPERATIONS

This section describes the basic power operations of the camera system.

POWER PRIORITY

When multiple power sources are connected to the camera, power consumption is prioritized in this sequence:

1. Any power supply connected to the DC IN port on the camera
2. Any power supply connected to Power IN (Studio In) port on the DXL Hot Swap Module
3. Battery mounted to the DXL Hot Swap Module

POWER CONSUMPTION

The camera draws approximately 90W (15V at 6A) when configured with a Primo VF and an SSD.

The camera (via the DC-IN port) also provides approximately 72W (24V @ 3A) exclusively to power attached accessories and lens control devices. For more information, go to ["DC-IN" on page 141](#).

POWER STATUS

The power status of the current primary power source is displayed in the graphical user interface (GUI). Navigate to the Power In menu at **Menu > Maintenance > Power > Power In** for the status of all connected power sources.

APPROVED EXTERNAL DC POWER

The camera accepts input voltages of 11.5V to 17V DC, and can draw a maximum current of 9A. The camera can be powered continuously by connecting one (1) of the following to the DC IN port on the camera or attached DXL Hot Swap Module:

- ▶ GPS (Genesis Power Supply)
- ▶ S7PS (Super 70 Power Supply)

PANAVISION MILLENNIUM DXL2

TURN ON THE CAMERA

NOTE: If you have just turned off the camera, wait at least three (3) seconds before turning the camera back on.

1. Attach a power source to the camera.

The Power Status LED illuminates red, indicating that an appropriate power source is connected.

2. Press and release the **PWR/REC** key on the right side of the camera.

The Power Status LED illuminates amber as the camera turns on.

The Power Status LED illuminates green to confirm that the camera is turned on and ready to use.

TURN OFF THE CAMERA

Use one of the following methods to turn off the camera:

- ▶ Press and hold **PWR/REC** until the **Shutting Down...** notification shows on the display.

NOTE: The camera turns off automatically if the supply voltage drops to 11.5V.

PANAVISION MILLENNIUM DXL2

AUTO BOOT ON POWER

The camera features a selector switch that enables the camera to automatically boot when power is provided via the DC IN connector. The Auto Boot on Power switch (identified by a white star) is located on the back of the camera.

When Auto Boot on Power is enabled, the camera disables all power sources that are not the DC IN connector, including batteries and the DC IN connectors on any modules.



Figure: Auto Boot on Power Switch

ENABLE AUTO BOOT ON POWER

1. Toggle the **Auto Boot on Power** switch to **On** (identified by a white star).
2. Connect a power source to the **DC IN** connector.
The camera turns on automatically.
3. Turn off the camera by pressing and holding **PWR/REC** until the **Shutting Down...** notification shows on the display

NOTE: Simply disconnecting the power source may result in data loss.

PANAVISION MILLENNIUM DXL2

DISABLE AUTO BOOT ON POWER

1. Toggle the **Auto Boot on Power** switch to **Off** (identified by a black star).
The camera will not turn on automatically.

SET UP THE DXL HOT SWAP MODULE

INSTALL A DXL HOT SWAP MODULE

REQUIRED TOOL(S): T20 TORX driver

1. Place the adaptor plate (thin plate) on the back on the Panavision Millennium DXL2.
2. Position the DXL Hot Swap Module against the adaptor plate, aligning the connector on the front of the DXL Hot Swap Module with the connector on the rear of the camera.
3. Apply pressure and tighten the four (4) captive screws in a cross pattern ("X" pattern) approximately two (2) turns each using a T20 TORX driver. **DO NOT FULLY TIGHTEN.**

NOTE: Slide the battery plate down in order to access the top screws, and slide the battery plate up in order to access the bottom screws. For more information, go to ["Slide Battery Plate Up and Down" on the next page.](#)

4. Fully tighten the four (4) screws in a cross pattern ("X" pattern) using a T20 TORX driver.

WARNING: DO NOT OVERTIGHTEN.



Figure: Installed DXL Hot Swap Module

REMOVE A DXL HOT SWAP MODULE

REQUIRED TOOL(S): T20 TORX driver

1. Loosen the four (4) captive screws in a cross pattern ("X" pattern) using a T20 TORX driver.
NOTE: Slide the battery plate down in order to access the top screws, and slide the battery plate up in order to access the bottom screws. For more information, go to ["Slide Battery Plate Up and Down" on the next page.](#)
2. Remove the DXL Hot Swap Module.
3. Remove the adaptor plate.

PANAVISION MILLENNIUM DXL2

INSTALL GOLD MOUNT BATTERY

1. Install the DXL Hot Swap Module. For more information, go to ["Install a DXL Hot Swap Module" on the previous page](#).
2. Slide the battery onto the DXL Hot Swap Module, ensuring that the Gold Mount T-studs are aligned in the corresponding slots.

The latch clicks when the battery is installed.

REMOVE GOLD MOUNT BATTERY

1. While holding the battery, push down the black latch on the left side of the DXL Hot Swap Module.
2. Slide the battery to the left to remove the battery.

SLIDE BATTERY PLATE UP AND DOWN

The battery plate slides up and down the module, and can be locked into any position on the slide. The highest position is ideal for studio shoots, and the lowest position is ideal for hand-held shoots. To slide the battery plate, follow the instructions below:

1. Move the silver lever at the top of the DXL Hot Swap Module toward the right side (Assistant side) of the camera.
2. Slide the battery plate into the position you want it.
3. To lock the battery plate into place, move the silver lever at the top of the DXL Hot Swap Module toward the left side (Operator side) of the camera.

PANAVISION MILLENNIUM DXL2

RECORD

Perform one of the following actions to begin recording:

- ▶ Press **PWR/REC** on the camera.
- ▶ Press **REC** on the media bay.
- ▶ Enable record via:
 - ▶ RCP.
 - ▶ GPI through 7-pin AUX port.
 - ▶ 3-pin Fischer R/S through front 24V ports.
 - ▶ DXL Control smartphone app (for iOS or Android).



Figure: DXL Control App Interface

BASIC MENUS AND USER INTERFACE

GUI MENU INTRODUCTION

This section describes the structure and layout of the graphical user interface (GUI) on the operator and assistant side UI's. Additional advanced menu controls through a touchscreen enable access to edit overlays, presets, and other maintenance level settings.

The Operator and Assistant Side UIs each have up to four (4) pages that you can scroll through by using the Left and Right arrows. These pages are:

- ▶ **Home Page:** This is the page that displays when the camera turns on, and displays recording information and project settings. This page cannot be toggled on/off. For more information, go to ["Home Page" on the next page](#).
- ▶ **User Page:** This page displays recording information, but does not display project settings. Various statuses and shortcuts can be assigned to this page. For more information, go to ["User Page" on page 31](#).
- ▶ **Monitor Page:** This page displays the color space, gamma curve, overlays, and LUTs applied to each monitor. For more information, go to ["Monitor Page" on page 33](#).
- ▶ **Audio Page:** This page displays audio information. For more information, go to ["Audio Page" on page 34](#).

This section describes each page.

PANAVISION MILLENNIUM DXL2

HOME PAGE



Figure: Home Page

#	ITEM	DESCRIPTION	DETAILS
1	Frame Rate (fps)	Recording frame rate	"Frame Rate" on page 51
2	ISO	Camera sensitivity	"ISO" on page 38
3	Shutter	Integration time or shutter angle	"Exposure/Shutter" on page 54
4	Color Temperature	White balance and Tint	"Color Temperature" on page 37
5	Sensor Resolution	Record format (resolution)	Resolution
6	REDCODE®	REDCODE compression setting	"REDCODE" on page 45
7	Monitor	Shortcut to the Monitor page	"Home Page" above
8	Power Status	DC voltage in or % of remaining battery capacity	"Power Status" on page 36
9	Playback	Shortcut to Playback mode	"Playback " on page 104
10	Clip Information	Standby/Preview mode: Name of next clip; duration of previous clip. Record mode: Name and duration of current clip.	N/A
11	Timecode	Current timecode value	"Timecode" on page 55

PANAVISION MILLENNIUM DXL2

#	ITEM	DESCRIPTION	DETAILS
12	System Status Indicators	R3D/Proxy	"Select Record File Format" on page 50
		TC: Timecode	"TC Indicator" on page 35
		GEN: Genlock	"GEN Indicator" on page 35
		WiFi: Indicates WiFi connection	"WiFi Indicator" on page 35
		LAN	"LAN Indicator" on page 35
		Cal: T/E	"CAL: T/E Indicator" on page 36
13	Temperature	Temperature: Camera sensor and electronics temperature, respectively	"Sensor Calibration" on page 94



PANAVISION MILLENNIUM DXL2

USER PAGE



Figure: User Page

The information in the middle of the screen is identical to the information displayed on the Home Page. For more information, go to ["Home Page" on page 29](#). You can assign statuses and shortcuts to the eight (8) slots along the top and bottom of the screen.

CHANGE OR CLEAR ITEMS IN SLOTS ON USER PAGE

To change or clear an item in a slot, follow the instructions below:

1. Press and hold the arrow button on the camera.
2. Select the new item to assign to the slot. To clear the slot, select **NONE**.

ASSIGN ITEMS TO SLOTS ON USER PAGE

Use the arrow buttons on the camera to assign the following statuses and shortcuts to the slots:

ITEM	DESCRIPTION	DETAILS
None	Slot remains blank	N/A
Aperture	Aperture of lens	N/A
Camera Pitch	Angle of camera tilt up or down (measured in degrees; recorded per frame)	N/A
Camera Roll	Angle of camera around central axis from front to back of camera (measured in degrees; recorded per frame)	N/A
Color Space	Default color space. Shortcut to Color Space menu.	"Look Menu" on page 67
Color Temperature	Color Temperature. Shortcut to Color Temperature menu.	"Color Temperature" on page 37
Fan Speed: 1	Speed of Fan 1	"Temperature and Fan Status" on page 88

PANAVISION MILLENNIUM DXL2

ITEM	DESCRIPTION	DETAILS
Fan Speed: 2	Speed of Fan 2	"Temperature and Fan Status" on page 88
Fan: Maximum Preview Speed	The maximum speed of the fans in preview mode	"Fan and Temperature Management" on page 86
Fan: Maximum Record Speed	The maximum speed of the fans in record mode	"Fan and Temperature Management" on page 86
Focal Length	Focal length	N/A
Focus Distance	Focus distance	N/A
Focus Distance: Far	Maximum focal length	N/A
Focus Distance: Near	Minimum focal length	N/A
Format	Record format (resolution). Shortcut to Resolution menu.	Resolution
ISO	ISO. Shortcut to ISO menu.	"ISO" on page 38
LCD Brightness	Brightness of the attached LCD. Shortcut to LCD Brightness menu.	"LCD Brightness" on page 38
Magnify	Magnify setting. Shortcut to Magnify menu.	"Magnify" on page 39
REDCODE	REDCODE compression setting. Shortcut to REDCODE menu.	"REDCODE" on page 45
Frame Rate (fps)	Recording frame rate	"Frame Rate" on page 51
Temperature: Core	Camera core temperature	"Sensor Calibration" on page 94
Temperature: Sensor	Camera sensor temperature	"Sensor Calibration" on page 94
Tools	False color mode. Shortcut to Tools menu.	"Tools" on page 40



PANAVISION MILLENNIUM DXL2

MONITOR PAGE



Figure: Monitor Page

The first six (6) slots along the top and bottom of the screen show the monitor settings for the SDI ports and the Top VF (viewfinder).

#	ITEM	DESCRIPTION	DETAILS
1	SDI 1 SDI 2 SDI 3 SDI 4 SDI 5	Monitor preferences applied to each SDI out port	"Monitor Preferences" on page 57
2	Top Port	Monitor preferences applied to the top 16 pin serial port	"Monitor Preferences" on page 57
3	Color Space	Output color space	"Look Menu" on page 67
4	CDL	Shortcut to CDL menu	"Look Menu" on page 67

PANAVISION MILLENNIUM DXL2

AUDIO PAGE

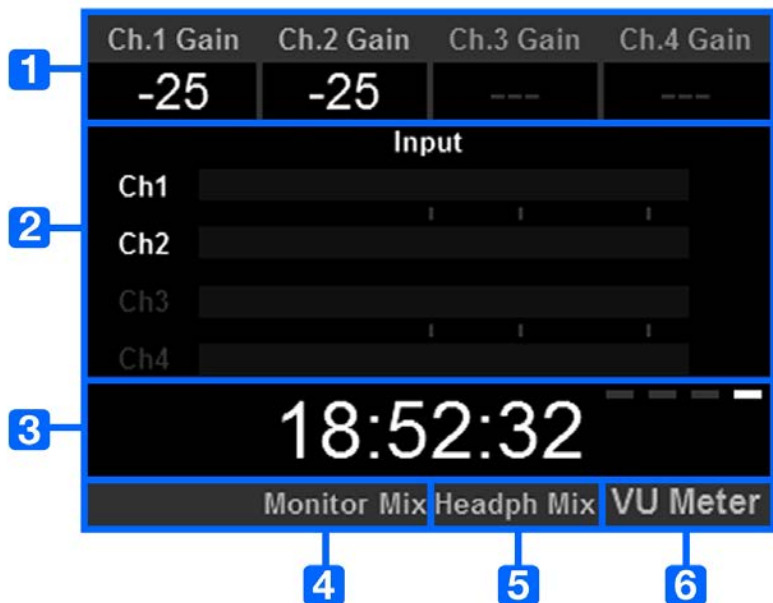

Figure: Audio Page

The Audio Page displays audio information from the internal microphone and any attached audio modules.

#	ITEM	DESCRIPTION	DETAILS
1	Ch. 1 Gain Ch. 2 Gain Ch. 3 Gain Ch. 4 Gain	Gain level for each audio channel	"Pre-Amp Gain" on page 109
2	Input	Volume for each audio channel	"Audio Meter (VU Meter)" on page 112
3	Timecode	Current timecode value	"Timecode" on page 55
4	Monitor Mix	Shortcut to the Monitor Mix	"Monitor Mix" on page 110
5	Headph Mix	Shortcut to the Headphone Mix	N/A
6	VU Meter	Toggle between Input and Output levels	"Audio Meter (VU Meter)" on page 112

PANAVISION MILLENNIUM DXL2

MENUS ONLY ACCESSIBLE VIA HOME AND USER PAGES

This section describes the status indicators and menus that are only accessible via the Home and User Pages.

SYSTEM STATUS INDICATORS

This section describes the colors and behavior of the System Status indicators in the Home Page.

TC INDICATOR

The TC indicator shows the current timecode status.

- ▶ **Gray:** No analog timecode is detected.
- ▶ **Red:** Analog timecode is detected but not enabled.
- ▶ **Green:** Analog timecode is used to jam the time of day timecode.

For more information, go to ["Timecode, Genlock, Multi-Camera Setup" on page 114](#).

WIFI INDICATOR

The WiFi indicator shows the WiFi status.

- ▶ **Gray:** WiFi is disabled.
- ▶ **Yellow:** WiFi is not connected.
- ▶ **Green:** WiFi is enabled.

For more information, go to ["WiFi" on page 80](#).

GEN INDICATOR

The GEN indicator shows the current genlock status.

- ▶ **Gray:** No genlock signal is detected, or the signal cannot cross-lock to project (24.00 fps vs. 23.98 fps).
- ▶ **Red:** During process of sync, or genlock is lost while recording.
- ▶ **Green:** A genlock signal matching the current HD-SDI monitor rate is locked.
- ▶ **Yellow:** Timing is cross-locked to compatible but not matching monitor rate. For example, genlock is 24.00 fps, and HD-SDI monitor rate is 25.00 fps.

NOTE: When the GEN indicator is yellow, DO NOT perform 3D operation. This warns that genlock source settings and camera settings are not aligned, so phasing of the sync between cameras is not guaranteed.

For more information, go to ["Timecode, Genlock, Multi-Camera Setup" on page 114](#).

LAN INDICATOR

The LAN indicator shows the current status of an external LAN connection through the Gig-E port.

- ▶ **Gray:** External control of the camera is not enabled.
- ▶ **Green:** Ethernet is enabled.

PANAVISION MILLENNIUM DXL2

CAL: T/E INDICATOR

The CAL: T/E indicator shows changes to temperature (T) or exposure (E) in relation to the active calibration map. If the temperature or exposure changes significantly, calibrate the sensor at the desired temperature and exposure. Failure to properly calibrate the sensor may reduce image quality.

- ▶ **Green:** Sensor temperature or exposure are properly calibrated for current settings.
- ▶ **Yellow:** Slight change in sensor temperature or exposure.
- ▶ **Red:** Significant change in sensor temperature or exposure.
- ▶ The – and + indicate whether the sensor temperature or exposure has decreased or increased, respectively.

NOTE: T and E indicators change colors independently of each other.

POWER STATUS

The Power Status element displays the current supply voltage or remaining battery capacity.

DC IN SUPPLY VOLTAGE

When powering the camera via DC power, the current voltage displays. When powering the camera using batteries, the remaining battery capacity displays. The remaining capacity is indicated by the following colors:

- ▶ **Green:** 12.0V and up
- ▶ **Yellow:** 11.8V to 11.9V
- ▶ **Red:** 11.6V to 11.7V

NOTE: The camera turns off automatically if the supply voltage drops to 11.5V.

PANAVISION MILLENNIUM DXL2

COLOR TEMPERATURE

To access the Color Temperature menu, select **Color Temp** from the Home Page.

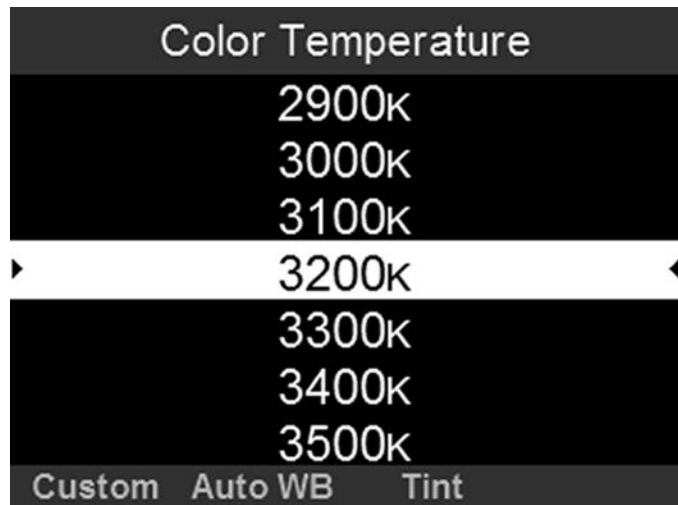

Figure: Color Temperature

Select a color temperature. The range is 1700 to 10,000 KELVIN, and the default is 5600 KELVIN.

TINT

Color temperature calculations assume a pure light source that may not be true in the specific scene the camera is imaging. To compensate for any residual colorcast, the Tint parameter adjusts the RGB color balance with a compensating magenta-green color component. Tint range is -100 to 100 , with a default of 0.000 .

NOTE: Selecting Auto White Balance calculates a new Tint value. The value does not change if you adjust the color temperature manually. Selecting a preset resets the Tint to 0.000 .

AUTO WHITE BALANCE

Auto white balance analyzes the central 25% of the image visible in the monitor to calculate a color temperature that will render a white object as white.

To use auto white balance, follow the instructions below:

1. Place a white or grey object under the ambient light.
2. Select **Color Temp** from the Home Page.
3. Select **Auto WB**.

PANAVISION MILLENNIUM DXL2

ISO

To set ISO, follow the instructions below:

1. Add **ISO** to the User Page. For more information, go to ["User Page" on page 31](#).
2. Select **ISO** from the User Page.
3. Select an ISO value.

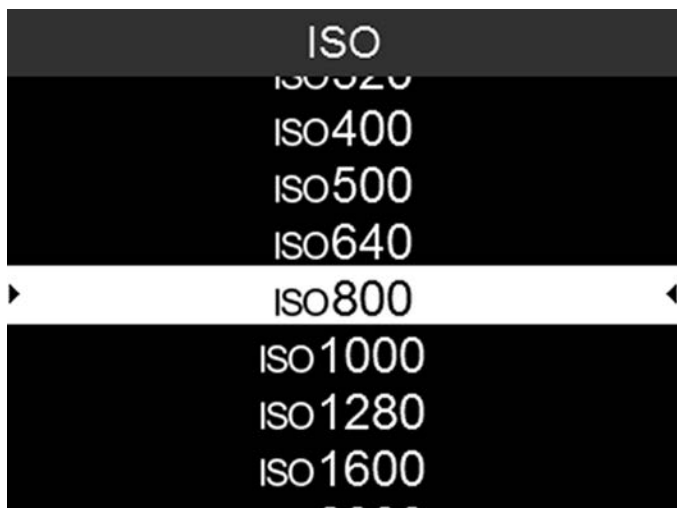

Figure: ISO

LCD BRIGHTNESS

To set the brightness of the Operator and Assistant Side UIs, follow the instructions below:

1. Add **LCD Brightness** to the User Page. For more information, go to ["User Page" on page 31](#).
2. Select **LCD Brightness** from the User Page.
3. Select a brightness value.

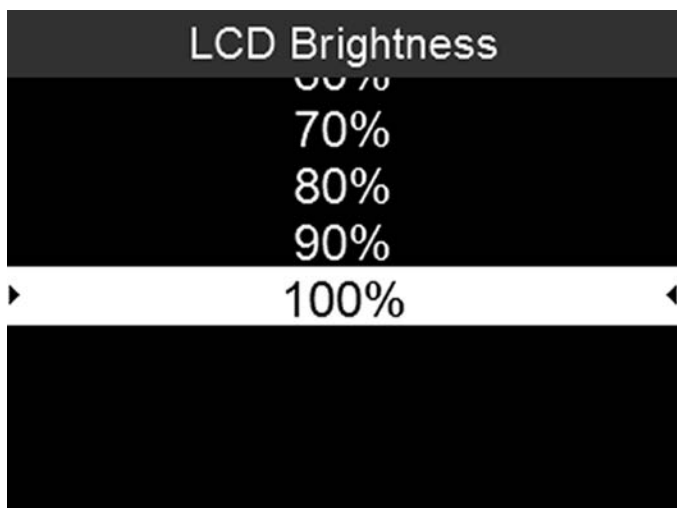

Figure: LCD Brightness

PANAVISION MILLENNIUM DXL2

MAGNIFY

The Magnify tool displays the central region of the sensor in 1:1 pixel resolution on an attached monitor. When enabled, the AF Window and the magnified region display. The AF Window determines the center point of the magnified region. If the lens or lens mount is not capable of autofocus with the camera, use Confirm mode to turn on the AF Window. Sharpening is disabled when Magnify mode is enabled. The camera automatically exits Magnify mode when recording begins.

The Magnify tool magnifies a 1920 x 1020 region, centered on a 1920 x 1080 display. If the resolution is lower than 1920 x 1020, the image border cannot be magnified. Use the following equations to determine the area of the image border that will not be magnified:

- ▶ **Border width:** $(1920 - W) / 2$
- ▶ **Border height:** $(1020 - H) / 2$

NOTE: Frame rate and resolution cannot be modified in Magnify mode.

ENABLE MAGNIFY

To enable Magnify, follow the instructions below:

1. Add **Magnify** to the User Page. For more information, go to ["User Page" on page 31](#).
2. Select **Magnify** from the User Page.
3. Select **1:1**.

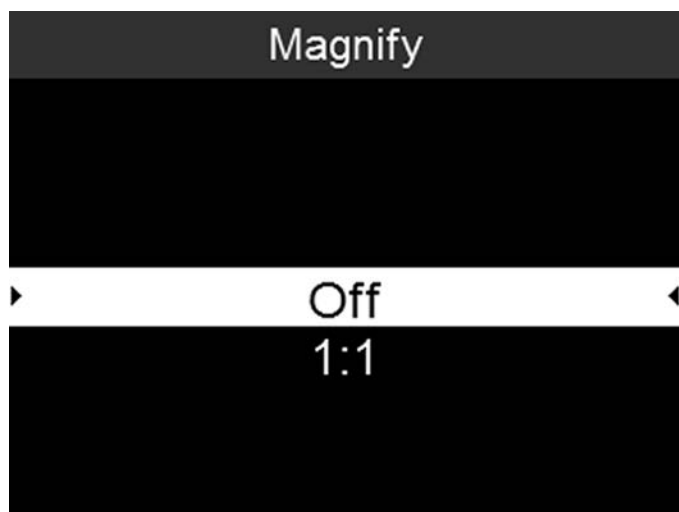

Figure: Magnify

PANAVISION MILLENNIUM DXL2

TOOLS

To enable a Tool, follow the instructions below:

1. Add **Tools** to the User Page. For more information, go to ["User Page" on page 31](#).
2. Select **Tools** from the User Page.
3. Select one of the following:
 - ▶ Exposure: For more information, go to ["Exposure" below](#).
 - ▶ Video: For more information, go to ["Video" on the next page](#).
 - ▶ Peaking: For more information, go to ["Peaking" on the next page](#).

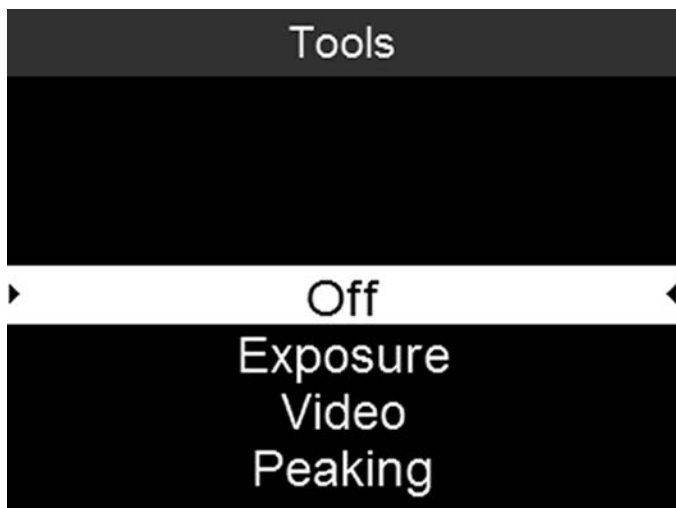

Figure: Tools

EXPOSURE

The Exposure tool displays a color overlay on top of a desaturated image that allows you to check for proper exposure.

The Exposure meter colors indicate the following information:

- ▶ **Purple**: Underexposed; indicates sensor exposure levels that may be noisy if gained up in post production.
- ▶ **Green**: IRE 41–48; based on the RGB levels of the video out signal and not the RAW data.
- ▶ **Red**: Overexposed; indicates sensor exposure levels that are clipping.

Purple (underexposure) and red (overexposure) are based on RAW data and show areas that are clipping or close to clipping. The RGB settings DO NOT affect the Exposure indicators.

PANAVISION MILLENNIUM DXL2

VIDEO

The Video tool displays a color overlay that indicates the video level of the RGB monitor path (calibrated to the SMPTE test signal).

Colors are based on the RGB levels of the video out signal (that is, the “cooked” look, and not RAW data). The RGB settings affect the Video indicators.

The Video indicators represent the following IRE values (at all other values, the desaturated image represents the luminance value of the ISO adjusted image):

- ▶ **Purple:** IRE 0–4
- ▶ **Blue:** IRE 5
- ▶ **Teal:** IRE 10–12
- ▶ **Green:** IRE 41–48
- ▶ **Pink:** IRE 61–70
- ▶ **Straw:** IRE 92–93
- ▶ **Yellow:** IRE 94–95
- ▶ **Orange:** IRE 96–98
- ▶ **Red:** IRE 99–100

PEAKING

The Peaking tool emphasizes contrast and edges in the image without changing brightness or image content making it easier to judge focus. Adjust zoom and focus to easily see which objects are coming into focus.

DETAILED MENUS

PROJECT SETTINGS

RESOLUTION

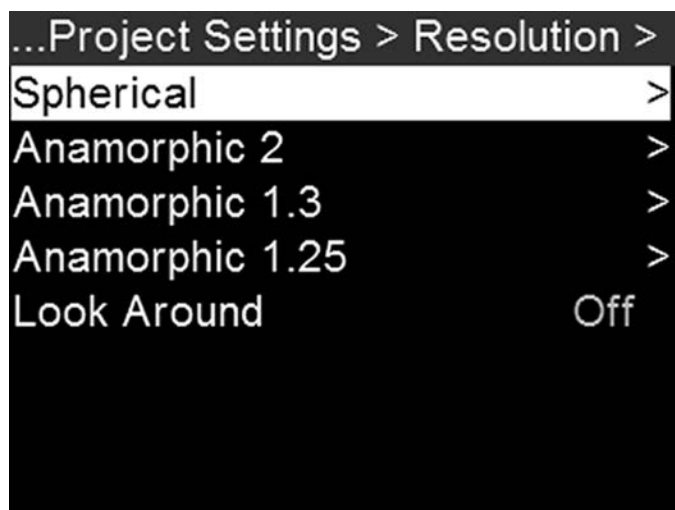

Figure: Resolution Menu

To select a resolution, go to **Menu > Project Settings > Resolution**.

Select a Spherical (non-anamorphic) or Anamorphic option, and then select the resolution and aspect ratio. The default format for Panavision Millennium DXL2 is 8K 2:1.

The table below describes the formats that are available for Panavision Millennium DXL2.

The table below omits rows for the anamorphic formats, since the pixel dimensions for each anamorphic format and the corresponding non-anamorphic format are the same. For more information, go to ["Anamorphic" on page 44](#).

RESOLUTION	DIMENSIONS (PIXELS)		DIMENSIONS (MM)		
	WIDTH	HEIGHT	WIDTH	HEIGHT	DIAGONAL
8K Full Format	8192	4320	40.96	21.60	46.31
8K 2:1	8192	4096	40.96	20.48	45.79
8K 2.4:1 (WS)	8192	3456	40.96	17.28	44.46
8K 16:9 (HD)	7680	4320	38.40	21.60	44.06
7.5K Full Format	7680	4080	38.40	20.40	43.48
7.5K 2:1	7680	3840	38.40	19.20	42.93
7.5K 2.4:1 (WS)	7680	3240	38.40	16.20	41.68
7.5K 16:9 (HD)	7296	4104	36.48	20.52	41.86
7K Full Format	7168	3780	35.84	18.90	40.52

PANAVISION MILLENNIUM DXL2

RESOLUTION	DIMENSIONS (PIXELS)		DIMENSIONS (MM)		
	WIDTH	HEIGHT	WIDTH	HEIGHT	DIAGONAL
7K 2:1	7168	3584	35.84	17.92	40.07
7K 2.4:1 (WS)	7168	3024	35.84	15.12	38.90
7K 16:9 (HD)	6720	3780	33.60	18.90	38.55
6.5K Full Format	6656	3536	33.28	17.68	37.68
6.5K 2:1	6656	3328	33.28	16.64	37.21
6.5K 2.4:1 (WS)	6656	2808	33.28	14.04	36.12
6.5K 16:9 (HD)	6144	3456	30.72	17.28	35.25
6K Full Format	6144	3240	30.72	16.20	34.73
6K 2:1	6144	3072	30.72	15.36	34.35
6K 2.4:1 (WS)	6144	2592	30.72	12.96	33.34
6K 16:9 (HD)	5760	3240	28.80	16.20	33.04
5K Full Format	5120	2700	25.60	13.50	28.94
5K 2:1	5120	2560	25.60	12.80	28.62
5K 2.4:1 (WS)	5120	2160	25.60	10.80	27.78
5K 16:9 (HD)	4800	2700	24.00	13.50	27.54
4K Full Format	4096	2160	20.48	10.80	23.15
4K 2:1	4096	2048	20.48	10.24	22.90
4K 2.4:1 (WS)	4096	1728	20.48	8.64	22.23
4K 16:9 (HD)	3840	2160	19.20	10.80	22.03
3K Full Format	3072	1620	15.36	8.10	17.36
3K 2.4:1 (WS)	3072	1296	15.36	6.48	16.67
3K 16:9 (HD)	2880	1620	14.40	8.10	16.52
2K Full Format	2048	1080	10.24	5.40	11.58
2K 2.4:1 (WS)	2048	864	10.24	4.32	11.11



PANAVISION MILLENNIUM DXL2

ANAMORPHIC

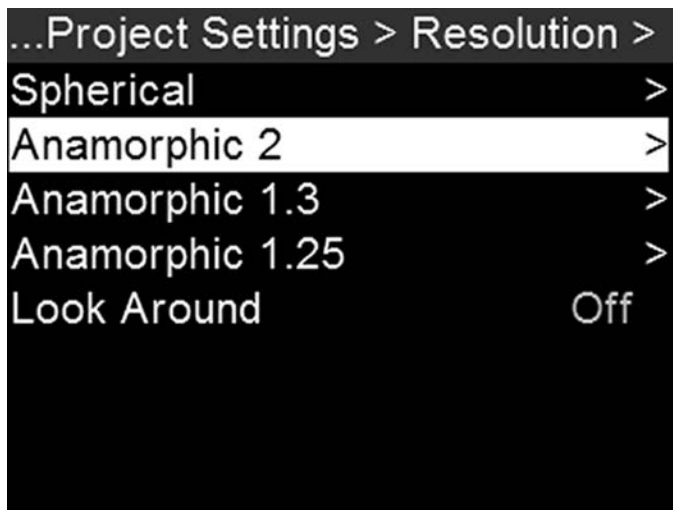

Figure: Anamorphic

The Panavision Millennium DXL2 supports the anamorphic options listed in the following sections.

ANAMORPHIC 2

- ▶ 8K 6.5
- ▶ 7.5K 6:5
- ▶ 7K 6.5
- ▶ 6.5K 6:5
- ▶ 6K 6.5
- ▶ 5K 6.5
- ▶ 4K 6.5

NOTE: Using a 6:5 aspect ratio at 2x anamorphic gives you a 2.4:1 aspect ratio.

PANAVISION MILLENNIUM DXL2

ANAMORPHIC 1.3

- ▶ 8K Full Format
- ▶ 8K 16:9 (HD)
- ▶ 7.5K Full Format
- ▶ 7.5K 16:9 (HD)
- ▶ 7K Full Format
- ▶ 7K 16:9 (HD)
- ▶ 6.5K Full Format
- ▶ 6.5K 16:9 (HD)
- ▶ 6K Full Format
- ▶ 6K 16:9 (HD)
- ▶ 5K Full Format
- ▶ 5K 16:9 (HD)
- ▶ 4K Full Format
- ▶ 4K 16:9 (HD)
- ▶ 3K Full Format
- ▶ 2K Full Format

ANAMORPHIC 1.25

- ▶ 8K Full Format
- ▶ 6K Full Format

LOOK AROUND

When Look Around is enabled, the Frame Guide and recording area are scaled down on the display so that you can see what images will enter the recording area.

To assign a Shading overlay to the Look Around area (the area outside of the recording area), go to ["Frame Lines" on page 60](#).

Look Around limits the available frame rates. At high resolutions, the recording area on the display shows the full sensor area or full sensor height, so there is no extra room for Look Around.

REDCODE

Select the target REDCODE compression ratio for your project.

If the camera is able to achieve the target compression ratio, the compression ratio displays in white. If the camera is unable to achieve the target compression ratio, the compression ratio displays in yellow, and the camera uses the next possible compression ratio.

The current compression ratio is automatically recalculated when changes are made to the project resolution, aspect ratio, anamorphic setting, frame rate, media, or the target REDCODE compression ratio.

The REDCODE compression affects the overall quality of the footage. A lower compression (for example: 2:1) increases the quality of the footage, while a higher compression (for example: 22:1) lowers the quality.

For more information, go to ["R3D File Format and REDCODE" on page 7](#).

PANAVISION MILLENNIUM DXL2

APPLE PRORES INFORMATION

By default, the camera records all videos and stills in the REDCODE RAW file format (records R3D files). You also have the option to record Apple ProRes files. This section provides general information about recording Apple ProRes files with the camera:

NOTE: If Look Around is enabled, the Look Around area is recorded in the Apple ProRes file.

- ▶ Selecting a Recording Frame Rate that is not supported by Apple ProRes has the following effects:
 - ▶ **4K Apple ProRes over 60 FPS:** Apple ProRes is disabled.
 - ▶ **4K Apple ProRes + R3D over 29.97 FPS:** Apple ProRes is disabled.
- ▶ The camera cannot record Apple ProRes when Pre-Record is enabled.
- ▶ Recording to R3D + Apple ProRes is not supported when the format is 4K FF.
- ▶ QuickTime files have the same metadata that is in the REDCODE RAW files. The metadata is per clip, and not per frame. At this time, there is no tool for extracting that metadata from the QuickTime files.
- ▶ You can select any resolution. When recording Apple ProRes, the camera scales that format to the Resolution (2K or 4K) selected in the Codec menu. The field of view is maintained in the QuickTime file; the image is not cropped.
- ▶ If recording 4K Apple ProRes and the Resolution is less than 4K, the image is scaled to 2K.
- ▶ For more information about Apple ProRes, including the data rates for each codec, see the Apple Support site at <https://support.apple.com/en-us/HT202410>.
- ▶ To record Apple ProRes files, go to "[Select Record File Format](#)" on page 50

PANAVISION MILLENNIUM DXL2

FILE STRUCTURE OF RECORDED APPLE PRORES FILES

When recording R3D + Apple ProRes, this is the file structure of the recorded files on the SSD (when the SSD is formatted as FAT32):

- ▶ .RDM Folder
 - ▶ .RDC Folder
 - ▶ .mov
 - ▶ .R3D
 - ▶ .rtn (RED Thumbnail file)

NOTE: The camera creates multiple .mov files, similar to how the camera creates multiple R3D files.

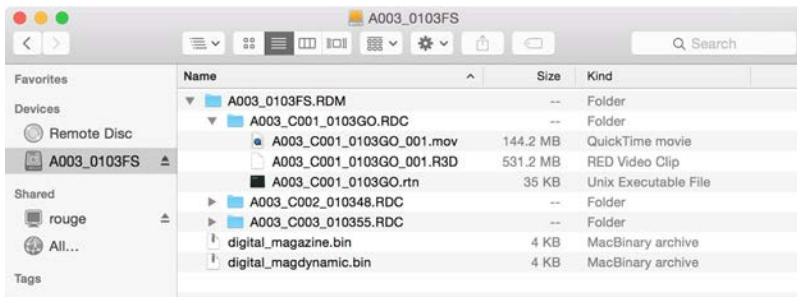

Figure: File Structure: R3D + Apple ProRes

When recording Apple ProRes only, this is the file structure of the recorded files on the SSD (when the SSD is formatted as FAT32):

- ▶ .RDM Folder
 - ▶ .RDC Folder
 - ▶ .mov

NOTE: The camera creates multiple .mov files, similar to how the camera creates multiple R3D files.

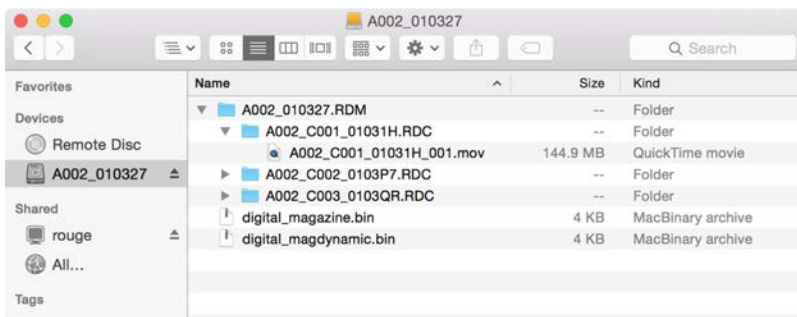

Figure: File Structure: Apple ProRes

PANAVISION MILLENNIUM DXL2

AVID DNxHD AND AVID DNxHR INFORMATION

By default, the camera records all videos and stills in the REDCODE RAW file format (records R3D files). You also have the option to record to Avid DNxHD and Avid DNxHR (records .mxf files). This section provides general information about recording Avid DNxHD/HR with the camera:

NOTE: If Look Around is enabled, the Look Around area is recorded in the Avid DNxHD/HR file.

NOTE: Enabling Look Around affects the aspect ratio of the scaled file, regardless of the recorded area.

- ▶ Selecting a Recording Frame Rate that is not supported by Avid DNxHD/HR causes the codec file to be sub-sampled to half of the selected Recording Frame Rate.
- ▶ The camera cannot record Avid DNxHD/HR when Pre-Record is enabled.
- ▶ The .mxf files have the same metadata that is in the REDCODE RAW files. The metadata is per clip, and not per frame. At this time, there is no tool for extracting that metadata from the .mxf files.
- ▶ You can select any resolution. When recording Avid DNxHD/HR, the camera scales that format to the Resolution (2K or 4K) selected in the Codec menu. The field of view is maintained in Avid DNxHD/HR; the image is not cropped.
- ▶ For more information about Avid DNxHD/HR, see the Avid website at www.avid.com/en/products/avid-dnxhr-and-dnxhd.
- ▶ To record Avid DNxHD/HR, go to "[Select Record File Format](#)" on page 50

AVID DNxHD AND AVID DNxHR DESCRIPTION

The table below describes each Avid DNxHD/HR codec.

NAME	CODEC ID	BITS	COLOR
DNxHR HQX	1271	12 bit	YCbCr 4:2:2
DNxHR HQ	1272	8 bit	YCbCr 4:2:2
DNxHR SQ	1273	8 bit	YCbCr 4:2:2
DNxHR LB	1274	8 bit	YCbCr 4:2:2
DNxHR 444	1270	12 bit	RGB 4:4:4
DNxHD 444	1256	10 bit	RGB 4:4:4
DNxHD HQX	1235	10 bit	YCbCr 4:2:2
DNxHD HQ	1238	8 bit	YCbCr 4:2:2
DNxHD SQ	1237	8 bit	YCbCr 4:2:2
DNxHD LB	1253	8 bit	YCbCr 4:2:2



PANAVISION MILLENNIUM DXL2

FILE STRUCTURE OF RECORDED AVID CODEC FILES

When recording R3D + Avid DNxHD/HR, this is the file structure of the recorded files on the SSD (when the SSD is formatted as FAT32):

- ▶ .RDM Folder
 - ▶ .RDC Folder
 - ▶ .R3D
 - ▶ .mxf (audio file, marked with an "A")
 - ▶ .mxf (video file, marked with a "V")
 - ▶ .rtn (RED Thumbnail file)

NOTE: The camera creates multiple .mxf files, similar to how the camera creates multiple R3D files.

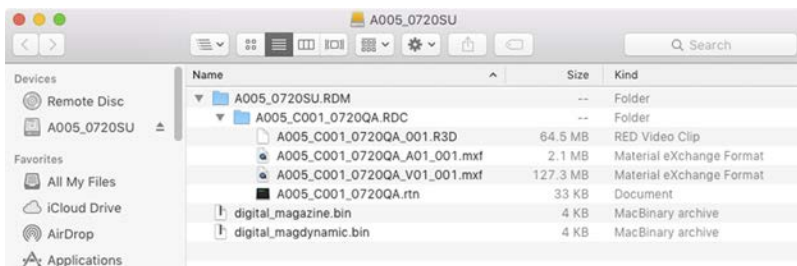

Figure: File Structure: R3D + DNxHD/HR

When recording Avid DNxHD/HR only, this is the file structure of the recorded files on the SSD (when the SSD is formatted as FAT32):

- ▶ .RDM Folder
 - ▶ .RDC Folder
 - ▶ .mxf (audio file, marked with an "A")
 - ▶ .mxf (video file, marked with a "V")
 - ▶ .rtn (RED Thumbnail file)

NOTE: The camera creates multiple .mxf files, similar to how the camera creates multiple R3D files.

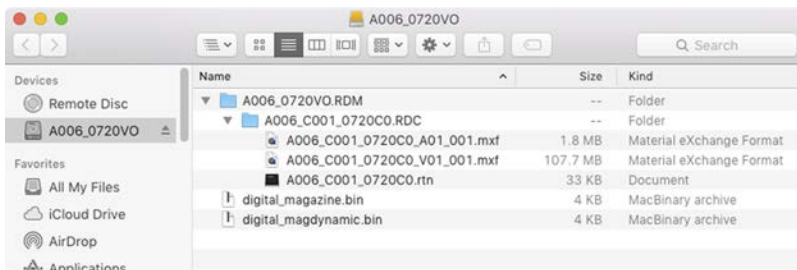

Figure: File Structure: R3D + DNxHD/HR

PANAVISION MILLENNIUM DXL2

SELECT RECORD FILE FORMAT

NOTE: For more information on which codecs your camera offers, go to ["Technical Specifications" on page 132](#).

To select what file formats to record to, follow the instructions below.

1. Go to **Menu > Project Settings > Codec**.

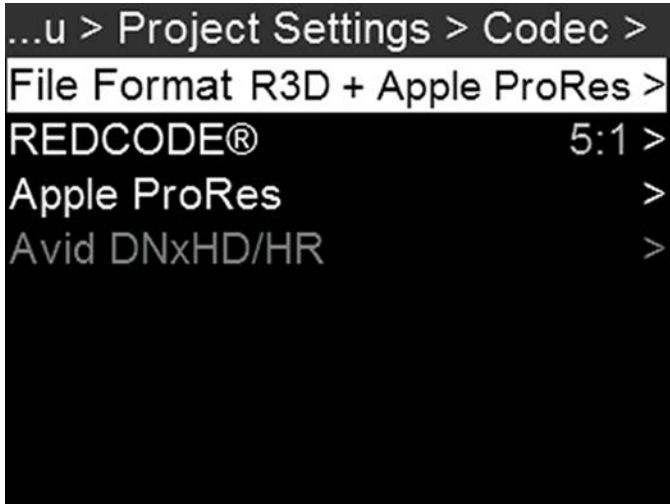

Figure: Codec Menu

2. Select the file format(s) you want to record to:

- ▶ R3D
- ▶ R3D + Apple ProRes
- ▶ R3D + Avid DNxHD/HR
- ▶ Apple ProRes
- ▶ Avid DNxHD/HR

The selected file format displays in the Lower Status Row.

3. **R3D:** Select a target REDCODE compression ratio. For more information, go to ["REDCODE" on page 45](#).

4. To set up Apple ProRes:

- A. In the Codec menu, select the **Apple ProRes** menu.
- B. Select the **Resolution**.
- C. Select the **Video Codec**.

The recording dimensions display at the bottom of the Apple ProRes menu.

5. To set up Avid DNxHD/HR:

- A. In the Codec menu, select the **Avid DNxHD/HR** menu.
- B. Select the **Resolution**.
- C. Select the **Video Codec**.

The recording dimensions display at the bottom of the Apple ProRes menu.

6. **Apple ProRes or Avid DNxHD/HR:** Select a codec from the **Record Video Codec** drop-down menu.

PANAVISION MILLENNIUM DXL2

FRAME RATE

RECORDING FRAME RATE

The recording frame rate is the number of frames per second (fps) that are recorded. The recording frame rate is different from the project time base, which is the rate at which the footage will be played back.

The default recording frame rate is 23.98 fps. If you change the project time base, the recording frame rate automatically changes its value to match the project time base.

The maximum frame rate for each format is determined by several factors, including project time base, REDCODE, and Look Around.

To set the recording frame rate, follow the instructions below:

1. Select **FPS** from the Home Page.
The Recording Frame Rate menu opens.
2. Select an option from the list, or select **Custom** to select a custom recording frame rate.

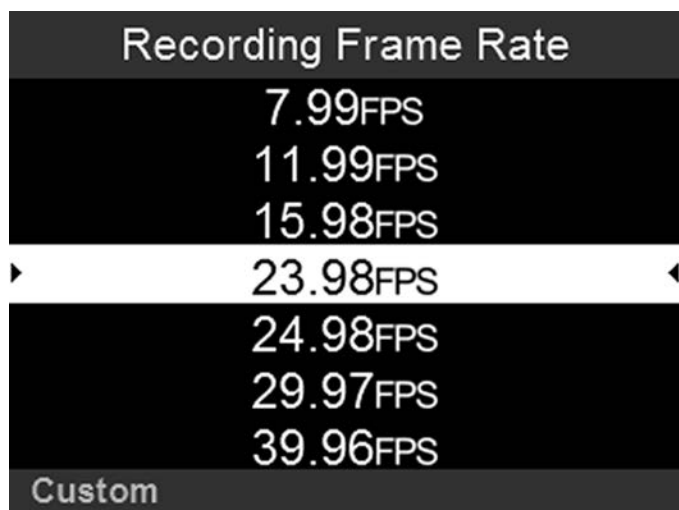

Figure: Recording Frame Rate

PANAVISION MILLENNIUM DXL2

PROJECT TIME BASE

The project time base is the rate at which the footage will be played back.

The following project time bases are available:

- ▶ 23.98 fps (Default)
- ▶ 24.00 fps
- ▶ 25.00 fps
- ▶ 29.97 fps
- ▶ 47.95 fps
- ▶ 48.00 fps
- ▶ 50.00 fps
- ▶ 59.94 fps

To select a project time base, follow the instructions below:

1. Go to **Menu > Project Settings > Timebase**.

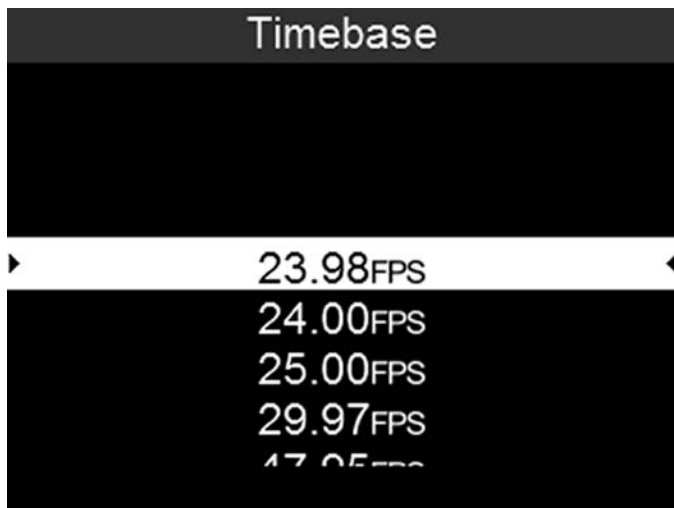

Figure: Timebase

VARISPEED

When a recording frame rate other than the current project time base is selected, the fps text turns yellow.

PANAVISION MILLENNIUM DXL2

SLATE

Use the Slate menu to add metadata to clips. After configuring the following fields, the information populates in the Media menu when formatting media:

- ▶ Camera ID
- ▶ Camera Position

To set the Slate information, follow the instructions below:

1. Go to **Menu > Project Settings > Slate**.
2. Set up the following:
 - ▶ Camera ID
 - ▶ Camera Position
 - ▶ Camera Color: Changes the color of the Clip Information slot on the user interface Home Page. For more information, go to "[Home Page](#)" on page 29.
 - ▶ Production
 - ▶ Director
 - ▶ DoP
 - ▶ Unit

PANAVISION MILLENNIUM DXL2

EXPOSURE/SHUTTER

Select the exposure (shutter speed / shutter angle) of each frame. You can change exposure while recording.

SHUTTER ANGLE

To set the shutter angle, follow the instructions below:

1. Go to **Menu > Project Settings > Shutter > Shutter Angle**.
2. Select an option from the list, or select **Custom** to select a custom shutter angle.

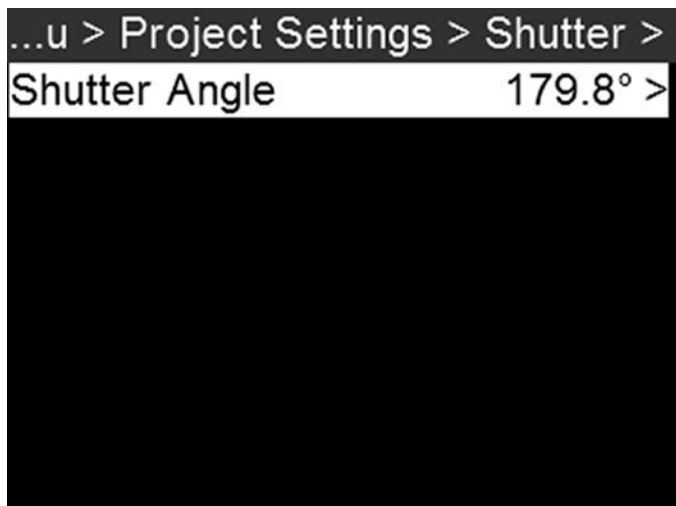

Figure: Shutter

EXPOSURE CONVERSIONS

The table below lists common shutter speed and shutter angle equivalents. The calculations in the table use a recording frame rate of 24 fps.

SHUTTER SPEED (1/XX SEC)	SHUTTER ANGLE (°)	SHUTTER SPEED (1/XX SEC)	SHUTTER ANGLE (°)
1/32	270	1/120	72
1/48	180	1/192	45
1/50	172.8	1/384	22.5
1/60	144	1/696	12.4
1/96	90	1/1000	8.6

CONVERT SHUTTER SPEED TO SHUTTER ANGLE

Shutter Angle = (Shutter Speed x Frame Rate x 360)

Example: $(1/48 \times 24 \times 360) = 180$

CONVERT SHUTTER ANGLE TO SHUTTER SPEED

Shutter Speed = $1/(\text{Frame Rate} \times 360/\text{Angle})$

Example: $1/(24 \times 360/180) = 1/48$

PANAVISION MILLENNIUM DXL2

TIMECODE

To set up timecode, go to **Menu > Project Settings > Timecode**.

For more information about timecode, go to "[Timecode, Genlock, Multi-Camera Setup](#)" on page 114.

TIMECODE SOURCE	MODE	DESCRIPTION
RTC	Use Real Time Clock (RTC)	Uses the internal Real Time Clock as the timecode counter source. You can set the hours, minutes, and seconds in the numerical boxes on the screen.
External	Varies by device	Uses the timecode from an external device connected to the TIMECODE port on the camera.
ACN	Use ACN	Enables the camera to directly interact with the wireless Ambient communication and synchronization network (ACN™). This delivers line-accurate syncing of all production cameras while syncing picture with sound. The signal also includes metadata. This can be accessed via the TIMECODE port (5-pin LEMO) on the Communication Module. For more information, go to " TIMECODE " on page 146.

LTC OUT

Enable **LTC Out** to output the linear timecode signal generated by the camera through the TIMECODE port on the camera.

NOTE: If jamming camera timecode to a timecode device, ensure that LTC Out is disabled.

To enable LTC Out, follow the instructions below:

1. Go to **Menu > Project Settings > Timecode**.
2. Select LTC Out to toggle this feature on/off.

WIRELESS CHANNEL

If the Timecode Source is set to ACN, you can sync wireless timecode devices with the camera.

To select a wireless channel, follow the instructions below:

1. **Menu > Project Settings > Timecode**.
2. Set **Wireless Channel** to the same wireless channel as the device. The camera supports channels 11 to 18.

PANAVISION MILLENNIUM DXL2

PRE-RECORD

To set up Pre-Record, go to **Menu > Project Settings > Pre-Record**.

When enabled, the Pre-Record setting continuously captures a cache of footage before recording starts. Select to have 4 to 30 seconds (incremented at two second intervals) of pre-record time added to the actual footage. When Pre-Record is enabled, you will not miss the start of a shot by being a little slow on the trigger.

- ▶ **Duration:** Select the pre-record time.
- ▶ **Always trigger:** When selected, Pre-Record always starts when recording starts:
 - ▶ Press **PWR/REC** to activate Pre-Record.
 - ▶ Press **PWR/REC** a second time to start recording.
 - ▶ Press **PWR/REC** a third time to stop recording.
- ▶ **Trigger Pre-Record:** When selected, the Pre-Record menu closes and Pre-Record mode starts.

NOTE: Always perform a Full Format before using Pre-Record. A Full Format restores the SSD back to factory out-of-box settings, and optimizes the SSD for Pre-Record.

NOTE: Pre-Record puts your SSD in a state of constant record. As with any SSD technology, continuously writing data over an extended period of time will impact the lifespan of the media.

PANAVISION MILLENNIUM DXL2

MONITORING

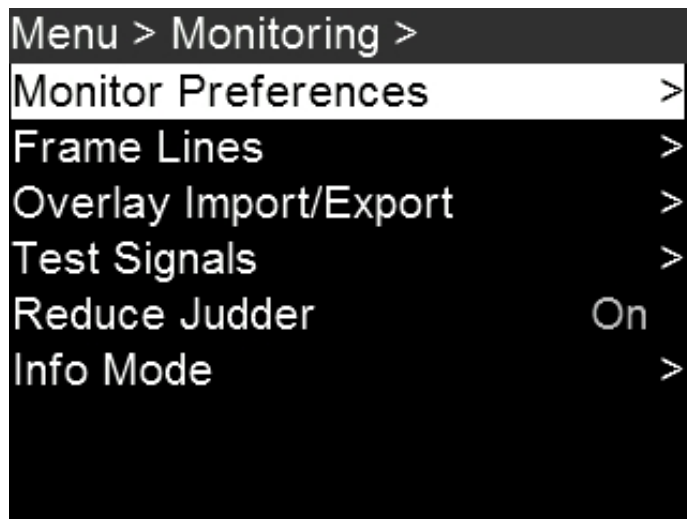

Figure: Monitoring Menu

MONITOR PREFERENCES

To set up monitor preferences, go to **Menu > Monitoring > Monitor Preferences** and select the monitor whose preferences you want to change. You can set up preferences for each of the following monitors:

- ▶ SDI 1
- ▶ SDI 2
- ▶ SDI 3
- ▶ SDI 4
- ▶ SDI 5
- ▶ UHD
- ▶ Assistant Port
- ▶ Top Port
- ▶ Operator Port

To see what monitor preferences are available, go to ["Monitor " on the next page.](#)

PANAVISION MILLENNIUM DXL2

ALL MONITOR FLIP

To flip the image upside-down in all connected monitors (for example, when shooting with a Steadicam in low mode), follow the instructions below:

1. Go to **Menu > Monitoring > Monitor Preferences**.
2. Scroll down to **All Monitor Flip** and toggle On/Off.

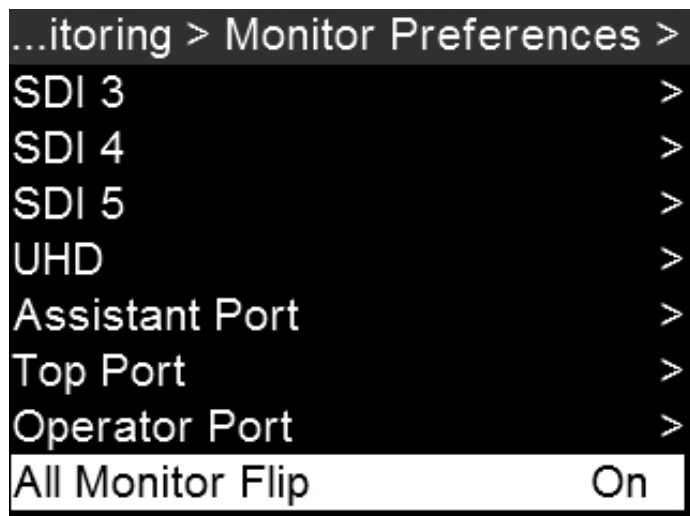

Figure: All Monitor Flip

MONITOR

NOTE: While some changes take effect immediately, others take effect when you close the menu.

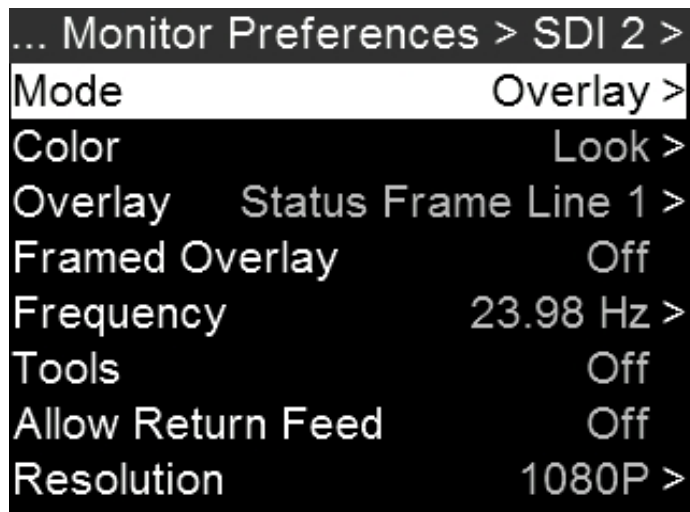

Figure: Monitor Preferences

PANAVISION MILLENNIUM DXL2

MONITOR MODE

Select an option for the **Mode** setting, which determines the elements displayed on the monitor:

- ▶ **Clean:** Only the video displays.
- ▶ **Overlay:** The overlay displays.
- ▶ **Mirror:** The monitor mirrors another screen at the same resolution. You cannot mirror a screen that is set to Clean. The Mirror option is available based on the settings of the other attached monitors, and includes the name of the monitor that can be mirrored.

COLOR

Select an option for the **Color** setting, which determines the color profile that will display on the monitor:

- ▶ **Look:** The chosen LUT and CDL settings will display.
- ▶ **LOG:** The LOG feed, without any LUT or CDL settings, will display.

OVERLAY

Select which overlay shows on top of the video. The camera comes with preset overlays. To see what overlays are available, go to ["Overlay Import/Export" on page 62](#).

RESOLUTION

Select the output resolution for monitors. You cannot select a resolution for view finders (VFs), since the resolution is determined automatically. For more information about available HD-SDI and HDMI resolutions, go to [3G-SDI \(HD-SDI\) Out](#) and [HDMI Out](#).

FREQUENCY

Determines the monitor frequency. Available frequencies depend on the selected monitor.

For HD-SDI monitors, the frequency depends on the project time base. For more information, go to [3G-SDI \(HD-SDI\) Out](#) and [HDMI Out](#).

HD-SDI Auto: Sets the frequency equal to the Project Time Base, except when the Project Time Base is 47.95/48 fps. When the Project Time Base is 47.95/48 fps, the frequency is half that rate (23.98/24 Hz).

TOOLS

Enables the false color modes on the monitor. For more information, go to [Tools](#).

FRAMED OVERLAY

The video display is scaled down on the monitor so that the overlay items fit outside of the video area rather than over it. This setting only affects the monitor, and does not affect captured footage.

PANAVISION MILLENNIUM DXL2

ALLOW RETURN FEED

The camera allows you to input a 1080p 3G video feed into the camera, and then display that video on another monitor. To feed video into the camera and display it on a monitor, follow the instructions below:

1. Input an external feed:
 - A. Connect the device with the feed to the RETURN connector on the camera. For more information, go to ["RETURN" on page 143](#).
2. Enable the monitor to support the external feed:
 - A. Go to **Menu > Monitoring > Monitor Preferences**.
 - B. Select the monitor you want to see the live feed on.
 - C. Enable **Allow Return Feed**.
3. Map a key that will toggle between the actual feed and the external feed:
 - A. Go to **Menu > User Presets > Key Mapping**.
 - B. Select the key you want to map.
 - C. Select **Return Feed**.
4. When you are ready to display the external feed on the monitors, press the key mapped to **Return Feed**.

FRAME LINES

To set up the frame lines, go to **Menu > Monitoring > Frame Lines**. The camera offers up to three (3) frame lines:

- ▶ Frame Line 1
- ▶ Frame Line 2
- ▶ Frame Line 3

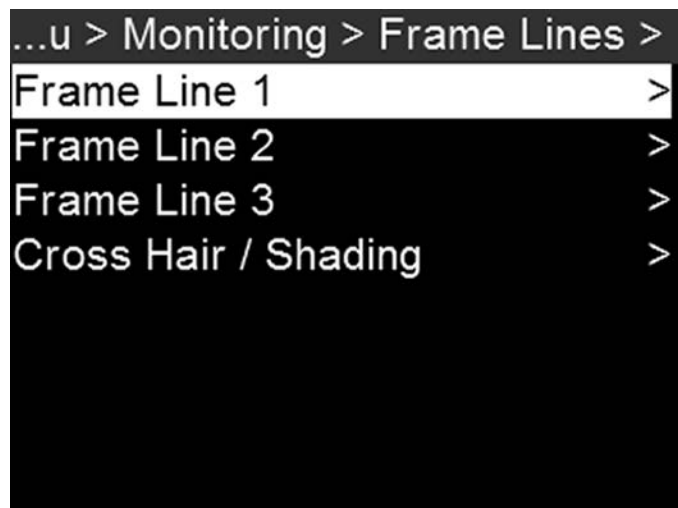

Figure: Frame Lines

PANAVISION MILLENNIUM DXL2

MODE

- ▶ **Off:** Disable all guides.
- ▶ **Full:** Guide has the same aspect ratio as the record format.
- ▶ **4:3, 16:9, 1.85:1, 1.9:1, 2.4:1:** Guide has the selected aspect ratio.
- ▶ **User:** When you select User, the Mode menu closes and the Frame Line menu opens. Select **User Aspect Ratio** and select the aspect ratio you want.
- ▶ **Absolute:** Guide is defined by absolute pixel dimensions rather than aspect ratio and scale. When you select Absolute, the Mode menu closes and the Frame Line menu opens. Select and set up the following:
 - ▶ Absolute Offset X
 - ▶ Absolute Offset Y
 - ▶ Absolute Width
 - ▶ Absolute Height

SCALE

Percentage to scale guide from its maximum possible size. Available range is 0 to 100%.

OFFSET X/Y

Percentage to offset guide from its default centered position. Available range is -100 to 100%.

- ▶ **100%:** Right-aligned (for X offset) and bottom-aligned (for Y offset).
- ▶ **-100%:** Left-aligned (for X offset) and top-aligned (for Y offset).

APPEARANCE

- ▶ **Line Style:** Select one of the following line styles: Solid, Dashed, or Bracket.
- ▶ **Color:** Select the color that has the highest contrast to the scene. The default is White.
- ▶ **Opacity:** Set the guide opacity. Available options are 25%, 50%, 75% and 100%.

CROSS HAIR / SHADING

Enable/Disable and select the location (Relative To), color, and opacity of the following elements:

- ▶ **Center:** The center crosshair.
- ▶ **Shading:** The shaded region outside of the area of interest.

PANAVISION MILLENNIUM DXL2

OVERLAY IMPORT/EXPORT

Overlays can be stored on the camera or transferred to SSD to be shared with other cameras. To apply an overlay to a monitor, go to ["Monitor Preferences" on page 57](#).

- ▶ **In Camera:** Overlays saved internally on the camera.
- ▶ **On Media:** Overlays saved to an SSD.

IMPORT FROM SSD TO CAMERA

To import overlays from an SSD to the camera, follow the instructions below:

1. Go to **Menu > Monitoring > Overlay Import/Export**.
2. Select **On Media: \overlays**.
3. Select one of the following:
 - ▶ Import
 - ▶ Import All

EXPORT FROM SSD TO CAMERA

To export overlays from the camera to an SSD, follow the instructions below:

1. Go to **Menu > Monitoring > Overlay Import/Export**.
2. Select **In Camera**.
3. Select one of the following:
 - ▶ Delete
 - ▶ Export
 - ▶ Export All

TEST SIGNAL

NOTE: Test signals are not recordable; they are provided to help align external HD-SDI monitors.

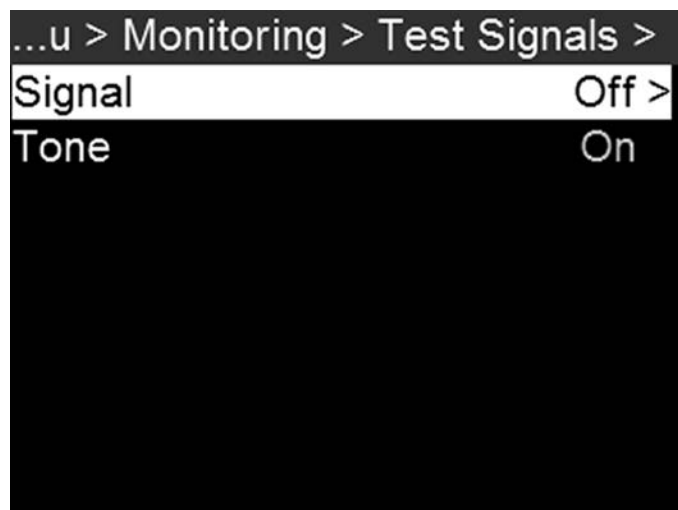

Figure: Test Signals

PANAVISION MILLENNIUM DXL2

SIGNAL

To apply a video test pattern, follow the instructions below:

1. Go to **Menu > Monitoring > Test Signals > Signal**.
2. Select one of the following options:
 - ▶ Off
 - ▶ Chip Chart
 - ▶ SMPTE Bars
 - ▶ Luma

AUDIO TONE

To apply an audio tone, follow the instructions below:

1. Go to **Menu > Monitoring > Test Signals**.
2. Toggle **Tone** On/Off.

REDUCE JUDDER

To reduce apparent judder when viewing the camera feed on an external monitor, follow the instructions below:

1. Go to **Menu > Monitoring**.
2. Scroll down to **Reduce Judder** and toggle On/Off.

NOTE: Reduce Judder can only be turned on when capturing in RAW format; it will not work if proxy mode is enabled.

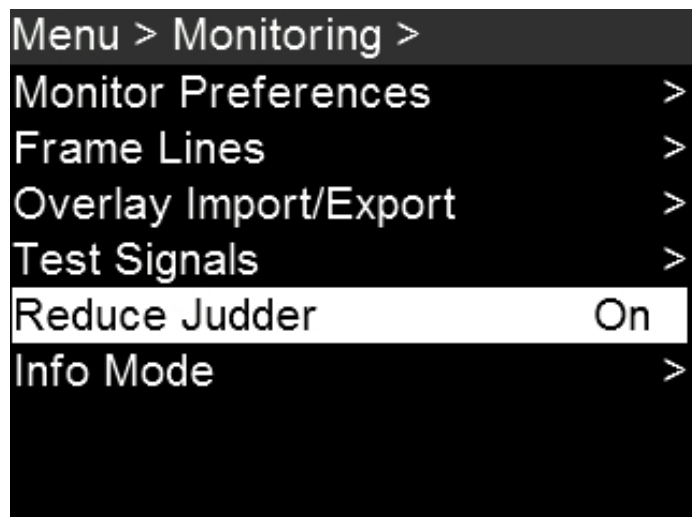

Figure: Reduce Judder

PANAVISION MILLENNIUM DXL2

INFO MODE

To set up how certain information displays on the user interface, go to **Menu > Monitoring > Info Mode**.

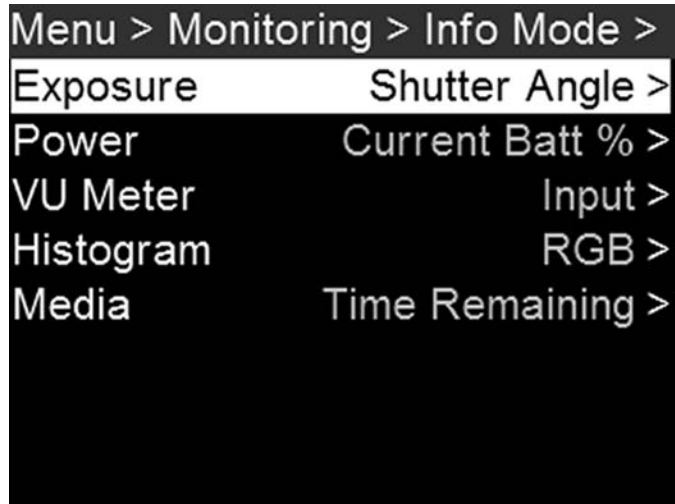

Figure: Info Mode

EXPOSURE

- ▶ **Shutter Angle:**When you change the frame rate in this mode, the shutter angle stays to the current setting
- ▶ **Shutter Speed:**When you change the frame rate in this mode, the shutter angle changes to compensate exposure change

POWER

- ▶ **Current Batt %:** Displays the remaining percentage of active battery. (Default)
- ▶ **Total Time:** Displays the total run-time left of battery power, taking into account all available batteries.

VU METER

- ▶ **Input:** Displays levels of audio inputs (pre-mixer). (Default)
- ▶ **Output:** Displays levels of audio outputs (post-mixer).

HISTOGRAM

- ▶ **RGB:** Displays red, green, and blue channels on histogram. (Default)
- ▶ **Luma:** Displays luma channel on histogram.

MEDIA

- ▶ **Percentage:** Displays media space remaining as a percentage. (Default)
- ▶ **Time Remaining:** Displays media space remaining as time in hours and minutes (HHH:MM).

PANAVISION MILLENNIUM DXL2

MEDIA MENU

EJECT MEDIA FROM CAMERA (UNMOUNT)

IMPORTANT: To ensure data integrity, media must always be unmounted prior to removal from the camera. This ensures that power is removed from the digital media and any open data files are closed. Failure to properly unmount media may result in lost data or corrupted files.

While removing an SSD without unmounting first does not damage the media, it does increase the risk of file corruption. It is good practice to unmount the media if possible before removing or disconnecting. Unmounting the digital media provides the following benefits:

- ▶ Protects the integrity of your recorded data
- ▶ Mounts clips instantly to your workstation in post production

EJECT MEDIA

1. To eject media, go to **Menu > Media > Eject Media**.
2. Select **Eject**.
3. Remove the SSD from the media bay.

FORMAT MEDIA OVERVIEW

The Panavision MINI-MAGs can be formatted as either FAT32 or UDF.

- ▶ **FAT32:** When an SSD is formatted as FAT32, all video clips (including R3D, .mov, and .mxf) are separated into 4GB segments (but display as a single clip when referenced together).
- ▶ **UDF:** When an SSD is formatted as UDF, .mov files are not split into multiple smaller files. However, R3D and .mxf files are still separated into 4GB segments.

Both Mac and Windows-based computers support SSDs formatted as either FAT32 or UDF. Refer to the documentation for your operating system to determine if there are any limitations to its support of file formats.

NOTE: FAT32 results in all proxy files greater than 4GB being spanned into separate .mov or .mxf files. Some software will not recognize these separate files as constituting a single clip, leading to delays as the files move into dailies, editorial, and beyond. Therefore, when employing the Panavision Millennium DXL2's optimized proxy workflow, it is recommended that all media be formatted as UDF during preproduction to ensure that all proxy takes will be preserved as self-contained files.

IMPORTANT: The Panavision Millennium DXL2 defaults to FAT32. When formatting media as UDF, follow the instructions below:

1. Go to **Menu > Media > File System**.
2. Select **UDF**.
3. Follow the instructions for ["Quick Format Media" on the next page](#) or ["Full Format Media" on the next page](#).

PANAVISION MILLENNIUM DXL2

QUICK FORMAT MEDIA

IMPORTANT: Ensure that data is backed up before formatting media, since formatting erases all data on the SSD.

To perform a Quick Format, follow the instructions below:

1. Insert a Panavision MINI-MAG into the media bay.
2. Go to **Menu > Media > Quick Format**.
3. Configure the following settings (optional):
 - ▶ Reel Number
 - ▶ Camera ID
 - ▶ Camera Position
 - ▶ Edge TC Start
4. Select **Quick Format Media**.
5. Select **Format**, and then select **Format** again.

FULL FORMAT MEDIA

Full Format is a low-level format that rebuilds the SSD file system and restores the SSD back to factory out-of-box settings. It should be used if the performance of the SSD is in question.

NOTE: To ensure optimal performance, particularly when switching between record and playback, it is recommended that each SSD be given a Full Format once every 10 to 12 shooting days.

IMPORTANT: Ensure that data is backed up before formatting media, since formatting erases all data on the SSD.

To perform a Full Format, follow the instructions below:

1. Go to **Menu > Media > Full Format**.
2. Configure the following settings (optional):
 - ▶ Reel Number
 - ▶ Camera ID
 - ▶ Camera Position
 - ▶ Edge TC Start
3. Select **Full Format Media**.
4. Select **Full Format**, and then select **Format**.

UPGRADE MEDIA FIRMWARE

In some instances, Panavision may offer firmware upgrades for the Panavision MINI-MAGs. If you have a media firmware upgrade file, follow the instructions below to upgrade media firmware:

1. Connect the Panavision MINI-MAG to a computer, and copy the media firmware upgrade file to the SSD.
2. Unmount the SSD from the computer, and insert it into the camera media bay.
3. Go to **Menu > Media > Utilities > Media Download Firmware**.
4. Select **Download Media Firmware**.

PANAVISION MILLENNIUM DXL2

LOOK MENU

To access the Look menu, go to **Menu > Look**.



Figure: Look Menu

CDL

Use the CDL menu to create and apply color-decision-list edits in-camera, with control over slope, power, offset, and saturation. To create a CDL, follow the instructions below:

1. Go to **Menu > Look > CDL**.
2. Individually set the values for slope, power, offset, and saturation.
3. Select **CDL Presets > In Camera**.
4. Press **Create**.
5. Select the created CDL and press **Apply**.

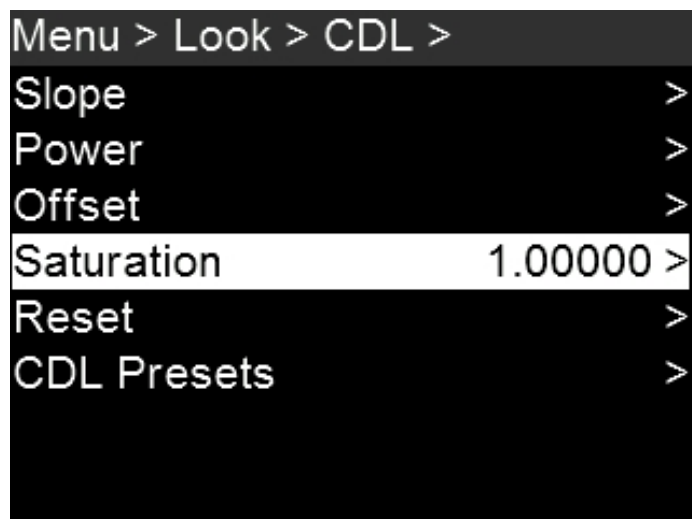

Figure: CDL Menu

PANAVISION MILLENNIUM DXL2

SET SLOPE

Red, green, and blue are each adjustable from 0 to 2 in increments of 0.1; the default is 1. To select a slope setting, follow the instructions below:

1. Go to **Menu > Look > CDL > Slope**.
2. Select individual slope settings for red, green, and blue.

SET POWER

Red, green, and blue are each adjustable from 0 to 4 in increments of 0.1; the default is 1. To select a power setting, follow the instructions below:

1. Go to **Menu > Look > CDL > Power**.
2. Select individual power settings for red, green, and blue.

SET OFFSET

Red, Green, and Blue are each adjustable from -1 to 1 in increments of 0.1; the default is 0. To select an offset setting, follow the instructions below:

1. Go to **Menu > Look > CDL > Offset**.
2. Select individual settings for red, green, and blue.

SET SATURATION

Saturation is adjustable from 0 to 4 in increments of 0.1; the default is 1. To select a saturation setting, follow the instructions below:

1. Go to **Menu > Look > CDL > Saturation**.
2. Select a saturation setting.

RESET CDL SETTINGS

To reset the camera's CDL settings and return each to its default, go to **Menu > Look > CDL > Reset**.

CDL IMPORT/EXPORT

To export and import CDLs, go to **Menu > Look > CDL > CDL Presets**.

CDLs can be stored on the camera or transferred to SSD to be shared with other cameras. When exporting CDLs from the camera to an SSD, the CDLs are saved to a folder on the SSD called "cdls". When importing CDLs from an SSD to the camera, the CDLs must be stored on the SSD in a folder called "cdls".

NOTE: The Panavision Millennium DXL2 can also receive CDLs wirelessly from Pomfort Livegrade. In order to do this, the camera must either be in Ad-Hoc mode (in which case the computer running Livegrade would select the camera as its WiFi network) or be in Infrastructure mode (in which case the camera and the computer would both connect to a common access point). For more information, go to ["Network Menu" on page 80](#).

PANAVISION MILLENNIUM DXL2

IMPORT FROM SSD TO CAMERA

To import CDLs from an SSD to the camera, follow the instructions below:

1. Go to **Menu > Look > CDL > CDL Presets**.
2. Select On **Media: \cdls**.
3. Select one of the following:
 - ▶ Import
 - ▶ Import All

APPLY IMPORTED CDL

To apply a CDL that has already been imported, follow the instructions below:

1. Go to **Menu > Look > CDL > CDL Presets**.
2. Select **In Camera**.
3. Scroll to the desired CDL, and then select **Apply**.

EXPORT FROM CAMERA TO SSD

To export CDLs from the camera to an SSD, follow the instructions below:

1. Go to **Menu > Look > CDL > CDL Presets**.
2. Select **In Camera**.
3. Select **1/2** to go to the next page.
4. Select one of the following:
 - ▶ Export
 - ▶ Export All

DELETE CDL

To delete a previously created or imported CDL, follow the instructions below:

1. Go to **Menu > Look > CDL > CDL Presets**.
2. Select **In Camera**.
3. Scroll to the desired CDL, and then select **Delete**.

PANAVISION MILLENNIUM DXL2

COMPATIBLE 3D LUT FORMATS

The Panavision Millennium DXL2 is compatible with the following 3D LUTs:

- ▶ DaVinci Resolve® 3D Cube LUT (.cube)
- ▶ IRIDAS/Adobe® 3D Cube LUT (.cube)
- ▶ Nucoda CMS 3D LUT (.cms)

The Panavision Millennium DXL2 is compatible with the following 3D LUT formats:

- ▶ 17x17x17
- ▶ 26x26x26
- ▶ 32x32x32
- ▶ 33x33x33

APPLY A 3D LUT

To apply a 3D LUT, follow the instructions below:

1. Go to **Menu > Look > 3D LUT > Choose LUT**.
2. Select a LUT.



Figure: Apply 3D LUT

LUT IMPORT/EXPORT

To export and import LUTs, go to **Menu > Look > 3D LUT > LUT Import/Export**.

3D LUTs can be stored on the camera or transferred to SSD to be shared with other cameras. When exporting 3D LUTs from the camera to an SSD, the 3D LUTs are saved to a folder on the SSD called "luts". When importing 3D LUTs from an SSD to the camera, the 3D LUTs must be stored on the SSD in a folder called "luts".

PANAVISION MILLENNIUM DXL2

IMPORT FROM SSD TO CAMERA

To import LUTs from an SSD to the camera, follow the instructions below:

1. Go to **Menu > Look > 3D LUT > LUT Import/Export**.
2. Select **On Media: \luts**.
3. Select one of the following:
 - ▶ Import
 - ▶ Import All

EXPORT FROM SSD TO CAMERA

To export LUTs from the camera to an SSD, follow the instructions below:

1. Go to **Menu > Look > 3D LUT > LUT Import/Export**.
2. Select **In Camera**.
3. Select one of the following:
 - ▶ Delete
 - ▶ Export
 - ▶ Export All

DELETING LUTS

To delete an existing LUT, follow the instructions below:

1. Go to **Menu > Look > 3D LUT > LUT Import/Export**.
2. Select **In Camera**.
3. Scroll to the desired LUT, and then select **Delete**.

NOTE: Light Iron Color 2 LUTs cannot be deleted.

PANAVISION MILLENNIUM DXL2

COLOR SPACE (DEFAULTS)

To set up the main output color space and gamma curve, follow the instructions below:

1. Go to **Menu > Look > Color Space**.
2. Select the default color space.



Figure: Color Space

NOTE: When the ACES color space is selected, certain features are disabled, and some menus offer different options.

PANAVISION MILLENNIUM DXL2

USER PRESETS MENU

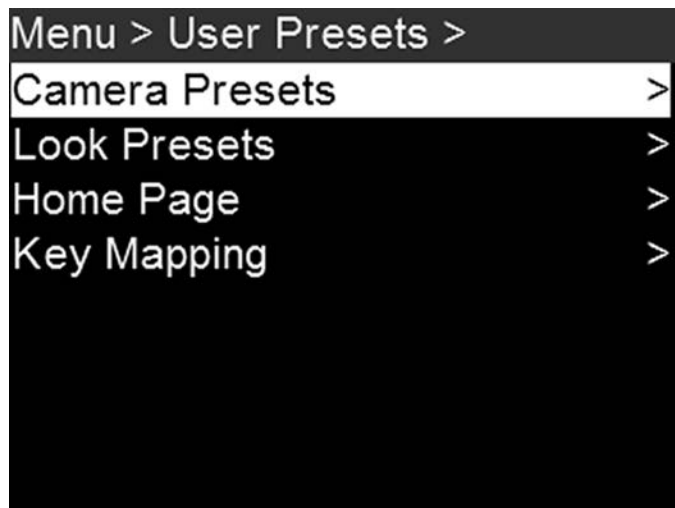

Figure: User Presets Menu

To access the User Presets menu, go to **Menu > User Presets**.

The camera has the following presets:

- ▶ **Camera Presets:** These store and recall camera setup information, such as in-camera Looks, key mappings, I/O configurations, and more. The camera has a number of factory-installed presets.
- ▶ **Looks:** These allow you to save the specific color, image, white balance, and detail settings to be used for other projects.

You can create custom presets and Looks. Presets and Looks can be stored on the camera or transferred to SSD, so that you can build a library of presets and Looks, or quickly copy presets and Looks from one camera to another via SSD.

- ▶ **Camera:** Presets or Looks that are saved internally on the camera.
- ▶ **Media:** Presets or Looks that are on the SSD in the path shown (for example, On Media: \presets:).

OTHER DEFAULTS

In addition to setting up presets, you can set up the following defaults in the User Presets menu:

- ▶ Home Page
- ▶ Key Mapping

CAMERA PRESETS

To manage camera presets, go to **Menu > User Presets > Camera Presets**.

CAMERA PRESET IMPORT/EXPORT

Presets can be stored on the camera or transferred to SSD to be shared with other cameras. When exporting presets from camera to an SSD, the presets are saved to a folder on the SSD called "Presets". When importing presets from an SSD to camera, the presets must be stored on the SSD in a folder called "Presets".

- ▶ **In Camera:** Presets saved internally on the camera.
- ▶ **On Media:** Presets saved to an SSD.

PANAVISION MILLENNIUM DXL2

IMPORT FROM SSD TO CAMERA

To import camera presets from an SSD to the camera, follow the instructions below:

1. Go to **Menu > User Presets > Camera Presets**.
2. Select **On Media: \presets**.
3. Select one of the following:
 - ▶ Import
 - ▶ Import All

EXPORT FROM SSD TO CAMERA

To export camera presets from the camera to an SSD, follow the instructions below:

1. Go to **Menu > User Presets > Camera Presets**.
2. Select **In Camera**.
3. Select one of the following:
 - ▶ Delete
 - ▶ Export
 - ▶ Export All

PANAVISION MILLENNIUM DXL2

LOOK PRESETS

To manage Look presets, go to **Menu > User Presets > Look Presets**.

LOOK PRESET IMPORT/EXPORT

Looks can be stored on the camera or transferred to SSD to be shared with other cameras. When exporting Looks from camera to an SSD, the presets are saved to a folder on the SSD called "Looks". When importing Looks from an SSD to camera, the Looks must be stored on the SSD in a folder called "Looks".

- ▶ **In Camera:** Looks saved internally on the camera.
- ▶ **On Media:** Looks saved to an SSD.

IMPORT FROM SSD TO CAMERA

To import Look presets from an SSD to the camera, follow the instructions below:

1. Go to **Menu > User Presets > Look Presets**.
2. Select **On Media: \looks**.
3. Select one of the following:
 - ▶ Import
 - ▶ Import All

EXPORT FROM SSD TO CAMERA

To export Look presets from the camera to an SSD, follow the instructions below:

1. Go to **Menu > User Presets > Look Presets**.
2. Select **In Camera**.
3. Select one of the following:
 - ▶ Apply
 - ▶ Export
 - ▶ Export All
 - ▶ Delete

PANAVISION MILLENNIUM DXL2

HOME PAGE PRESETS

The Operator and Assistant Side UIs each have up to four (4) pages that you can scroll through by using the Left and Right arrows. These pages are:

- ▶ **Home Page:** This is the page that displays when the camera turns on, and displays recording information and project settings. This page cannot be toggled on/off. For more information, go to ["Home Page" on page 29](#).
- ▶ **User Page:** This page displays recording information, but does not display project settings. Various statuses and shortcuts can be assigned to this page. For more information, go to ["User Page" on page 31](#).
- ▶ **Monitor Page:** This page displays the color space, gamma curve, overlays, and LUTs applied to each monitor. For more information, go to ["Monitor Page" on page 33](#).
- ▶ **Audio Page:** This page displays audio information. For more information, go to ["Audio Page" on page 34](#).

SET UP PAGE PRESETS

1. Go to **Menu > User Presets > Home Page**.
2. Select which Side UI to set up: **Operator** or **Assistant**.

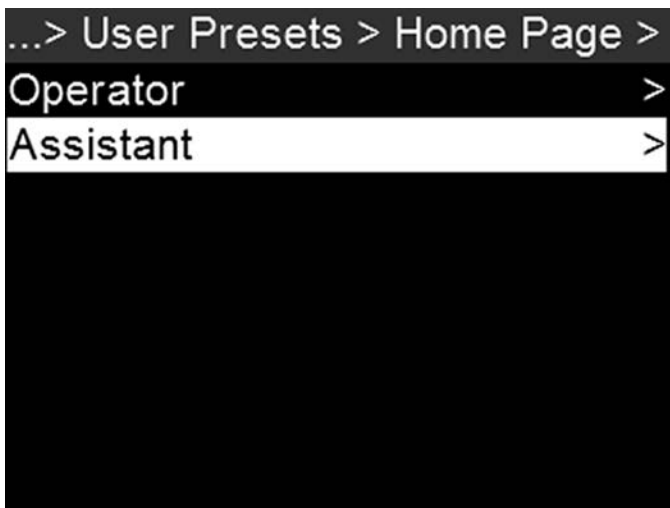

Figure: Select Which Side UI to Set Up

PANAVISION MILLENNIUM DXL2

3. To set up which pages the Side UI can toggle through, follow the instructions below:

A. Select **Visible Pages**.

B. Toggle the following on/off:

- ▶ User Page
- ▶ Monitor Page
- ▶ Audio Page

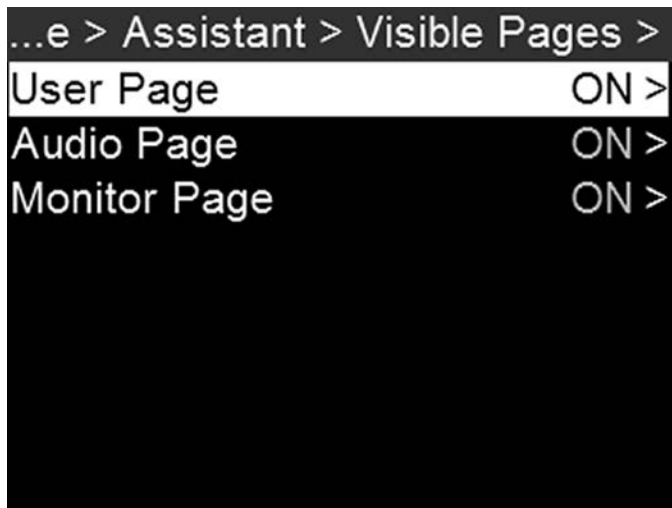

Figure: Toggle Pages On/Off

4. Press **Back** to return to the Operator or Assistant menu.

PANAVISION MILLENNIUM DXL2

5. To set up page change information, follow the instructions below:
 - A. Select **Auto Page Change**.
 - B. Select **Auto Home**.
 - C. Select one of the following:
 - ▶ **Stay on page**: The home page always displays.
 - ▶ **Change on Record**: If the Side UI is not on the home page, the Side UI returns to the home page when recording starts.
 - ▶ **Change After Time**: If the Side UI is not on the home page, the Side UI returns to the home page after the amount of time you specify in the next step.

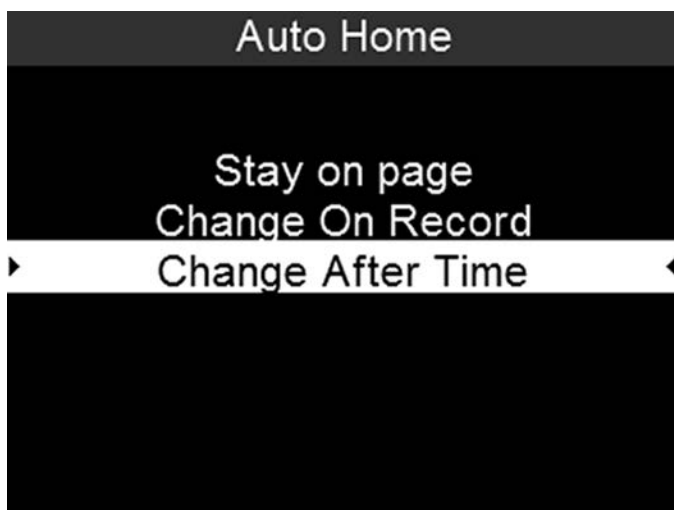

Figure: Select When Screen Should Return to the Home Page

- D. If you selected Change after Time, return to the Auto Page Change menu, select **Auto Home Timeout**, and select the timeout time.

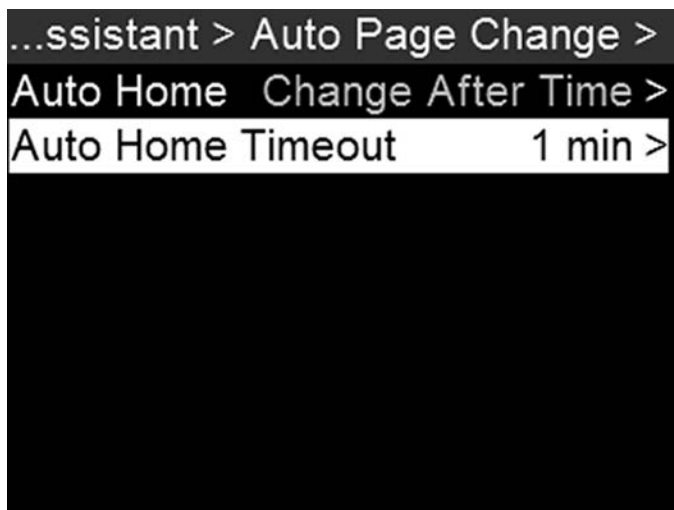

Figure: Select When Screen Should Return to the Home Page

PANAVISION MILLENNIUM DXL2

KEY MAPPING

To map or remap a user key, follow the instructions below:

1. Go to **Menu > User Presets > Key Mapping**.
2. Select the key you want to map.

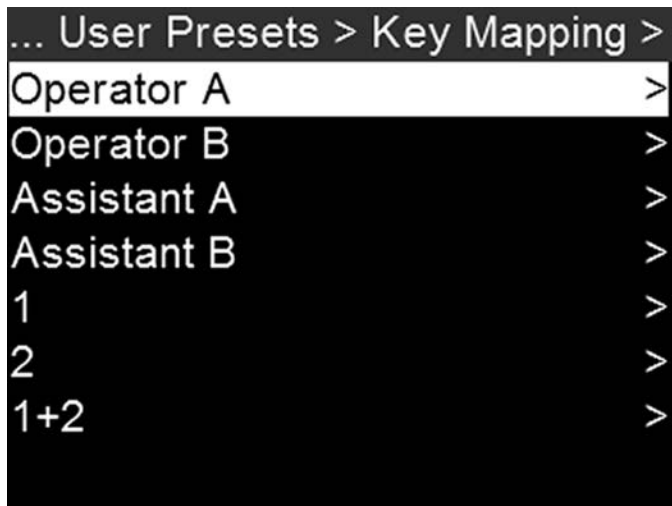

Figure: Select When Screen Should Return to the Home Page

3. Select the action that you want to map to the key and press **Enter**.

ASSIGNABLE ACTIONS

You can assign the following actions to a key:

- ▶ Auto WB
- ▶ Black Balance
- ▶ Camera Presets
- ▶ Eject Media
- ▶ Exposure
- ▶ Format Media
- ▶ Horizon
- ▶ Magnify
- ▶ Not Assigned
- ▶ Peaking
- ▶ Playback
- ▶ Record Start/Stop
- ▶ Return Feed
- ▶ Save UI Screen Shot
- ▶ Video

PANAVISION MILLENNIUM DXL2

NETWORK MENU

Use the Network menu to allow one (1) or more cameras to communicate with each other or external devices.

You can use an Ethernet cable to connect two (2) cameras, or one (1) camera and one (1) external device. If the camera is connected via Ethernet to a hub or router, multiple cameras and devices can communicate with each other.

For example, on a multi-rig 3D shoot, you can send commands to an individual camera (Example: Set CAM_A_L to 1/48 exposure), to a group of cameras (Example: Set 3DRIG_A to 48 fps), or to all cameras (Example: Start Recording on all cameras).

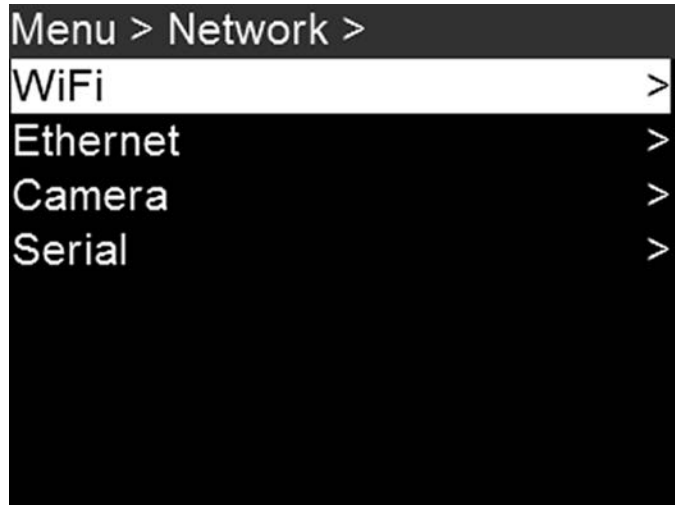

Figure: Network Menu

WIFI

The camera offers a WiFi connection that provides communication support for third-party applications. The camera uses the RED Command Protocol (R.C.P.) to communicate information between the camera and an application. As with all wireless devices, the communication range may be affected by the environment and any radio frequency (RF) interference that may be present. The WiFi frequency is 2.4 GHz.

There are two (2) ways to connect the camera to a device:

- ▶ **Ad-Hoc mode:** The camera and your device connect to each other.
- ▶ **Infrastructure mode:** The camera and your device both connect to an access point, and communicate through that wireless network.

NOTE: To connect the camera to an app, the app must have been programmed using the R.C.P. SDK, which is available through the R.C.P. Development Kit.

PANAVISION MILLENNIUM DXL2

CONNECT WIRELESSLY TO A DEVICE VIA AD-HOC MODE

In Ad-Hoc mode, the camera and your device connect to each other. To connect the camera to your device via an ad-hoc network, follow the instructions below:

1. Go to **Menu > Network > WiFi**.
2. Select **Ad-Hoc** from the **Mode** menu.
3. Select **AdHoc Settings** on the **WiFi** menu.
4. Select a wireless channel from the **Channel** menu. The default is Ch1, and you can select one out of 11 channels.
5. Select a security option from the **Encryption** menu:
 - ▶ **NONE**: The connection will be unsecured.
 - ▶ **WPA2**: The connection will be encrypted via WPA2.
6. If you selected WPA2 as the encryption option, type the passphrase that will be required to access the network.
7. Close the menu.

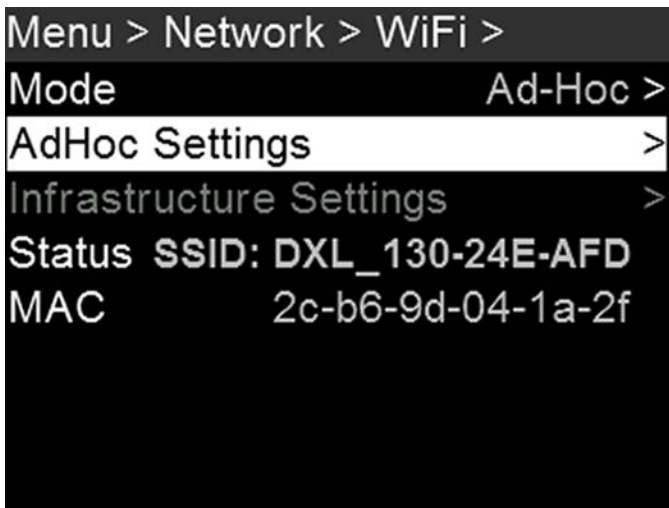

Figure: Ad-Hoc Mode

8. Connect your device to the ad-hoc network created by the camera. The steps in this procedure depend on what type of device and operating system you are using. For example, if you are connecting an iOS device, go to **Settings > Wi-Fi > Devices**, and select the camera name.

The camera name displays on the WiFi screen in-camera. The camera and your device are now connected.

NOTE: If you created a passphrase for the network, you will need to enter that passphrase. To enter the passphrase for the network, follow the instructions below:

- A. Select a security option from the **Encryption** menu.
- B. Select **Passphrase**.
- C. For each character in the password, use the **Scroll Wheel** to select a character. Turn clockwise to cycle through the characters in this order: uppercase alphabet, lowercase alphabet, numbers 0-9, characters (#, &, etc.).
- D. Press the **Left** and **Right** keys to move to the previous or next character, respectively.
- E. Select **Delete** to delete a character.
- F. Select **Clear** to clear the name.
- G. Once you have selected the passphrase you want, press **Enter**.

PANAVISION MILLENNIUM DXL2

CONNECT WIRELESSLY TO A DEVICE VIA INFRASTRUCTURE MODE

In Infrastructure mode, the camera and your device both connect to an access point, and communicate through that wireless network. The camera can connect to access points that are not encrypted, use WPA encryption, or use WPA2 encryption. To connect the camera to your device via an existing wireless network, follow the instructions below:

1. Connect your device to a wireless network. The access point for the network must have DHCP enabled.
2. Make sure that you know the name and password for the network, since you will need that information to connect the camera to the same network.
3. Go to **Menu > Network > WiFi**.
4. Select **Infrastructure** from the **Mode** menu.
6. Select **Infrastructure Settings** on the **WiFi** menu.

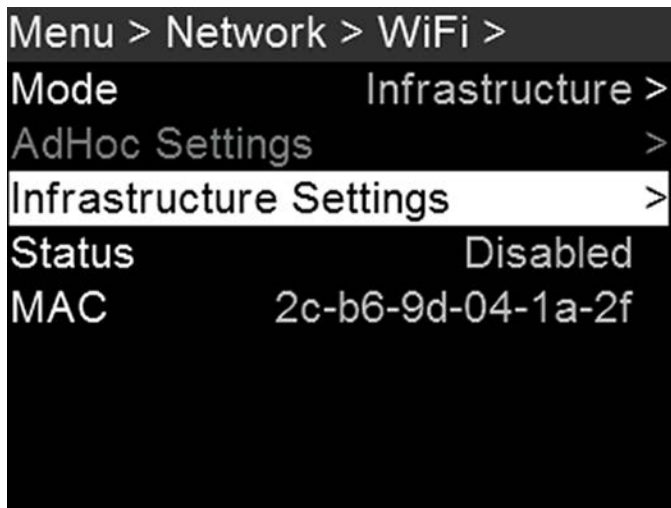

Figure: Infrastructure Mode

7. Select **Access Points**.
8. Select **Scan** to search for available wireless networks.
The available wireless networks (access points) display.
9. Highlight the wireless network that your device is connected to and select **Select**.
8. If you select an encrypted network, follow the instructions below to enter the passphrase for the network:
 - A. Select a security option from the **Encryption** menu.
 - B. Select **Passphrase**.
 - C. For each character in the password, use the **Scroll Wheel** to select a character. Turn clockwise to cycle through the characters in this order: uppercase alphabet, lowercase alphabet, numbers 0–9, characters (#, &, etc.).
 - D. Press the **Left** and **Right** keys to move to the previous or next character, respectively.
 - E. Select **Delete** to delete a character.
 - F. Select **Clear** to clear the name.
 - G. Once you have selected the passphrase you want, press **Enter**.
9. To enable/disable DHCP, select **IP Config** and set up the IP settings.

PANAVISION MILLENNIUM DXL2

10. In the Infrastructure menu, select **Connect**, and then select **Connect** again.

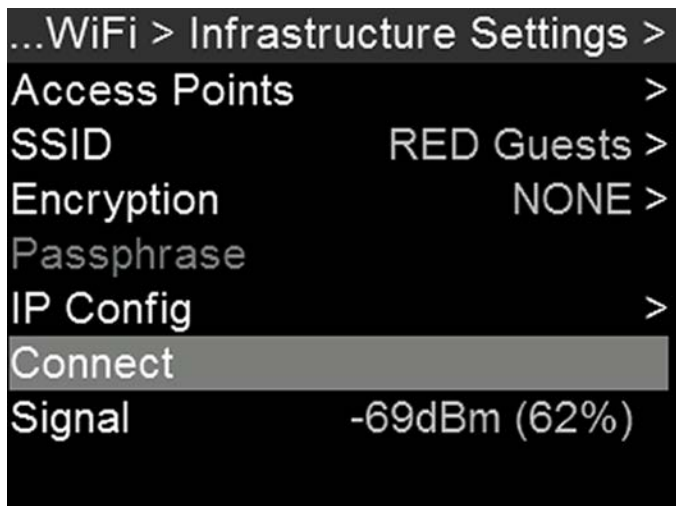

Figure: Connect to Network

11. Connect your device to the same wireless network that the camera is connected to. The steps in this procedure depend on what type of device and operating system you are using. For example, if you are connecting an iOS device, go to **Settings > Wi-Fi**, and select the wireless network.
The camera and your device are now connected.
12. To ensure that your app can communicate with the camera, ensure that there is a way to connect your app to a specific camera. Since there may be multiple cameras in the area, select your specific camera in the app itself.

PANAVISION MILLENNIUM DXL2

ETHERNET

To access Ethernet settings, go to **Menu > Network > Ethernet**.

Use the settings in the Ethernet menu to configure the GIG-E port. Each camera or device requires a unique IP address. For camera-to-camera communication via Ethernet, both cameras need to be in the same sub-net (have the same netmask address) and have the same gateway address.

In the Ethernet menu, you can enable/disable the following:

- ▶ **DHCP:** Enables DHCP. If a DHCP-server is available in the communications network, the camera obtains an IP address, netmask address, and gateway address automatically from the DHCP server. You cannot manually enter anything in the IP Address, Netmask, and Gateway fields when DHCP is enabled.
- ▶ **Camera to Camera:** A change to settings on this camera is sent to other cameras via the network as a SET command (as UDP packets). The SET command then sets the property on other cameras. If this camera receives a SET command, the camera does not send the command to other cameras/devices.
- ▶ **External Control:** This camera can be controlled via TCP/IP from an external device.

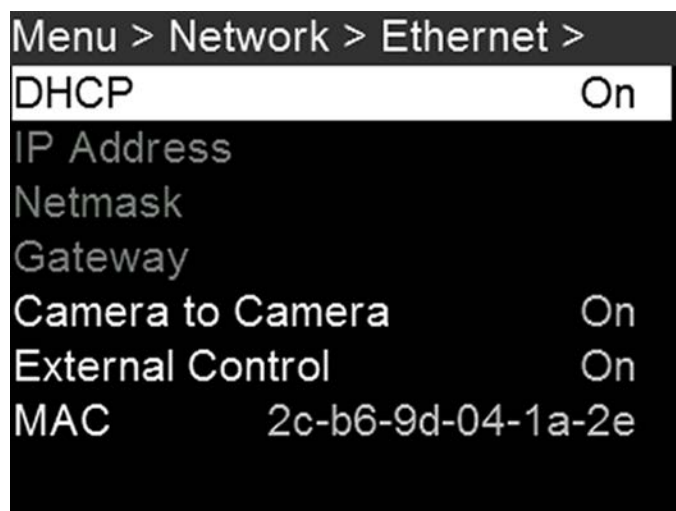

Figure: Ethernet Menu

PANAVISION MILLENNIUM DXL2

CAMERA

To access the Camera menu, go to **Menu > Network > Camera**.

Use the Camera menu to set up a unique identifier for your camera (or a group of cameras). All command filtering happens on the receiver side of the communication link. Use camera names and group names to address commands to a specific camera or group of networked cameras.

- ▶ **Camera ID:** Enter a unique camera name to use in network communications. The field is limited to eight (8) characters.
- ▶ **Group ID:** Enter a group name to identify the camera as a member of a group of devices. The field is limited to eight (8) characters, and the default name is DEFAULT.
- ▶ **Target:** Specify which devices the camera can send commands to:
 - ▶ **All:** The camera can send commands to all devices on the network.
 - ▶ **None:** The camera can only receive commands. The camera cannot send commands.
 - ▶ **Custom:** The camera can send commands to a specific camera/device (enter the name of the camera/device in the Target ID menu) or a specific group (enter the name of the group in the Target ID menu). The camera/group name must match the name entered in the Camera/Group field of the target device(s).

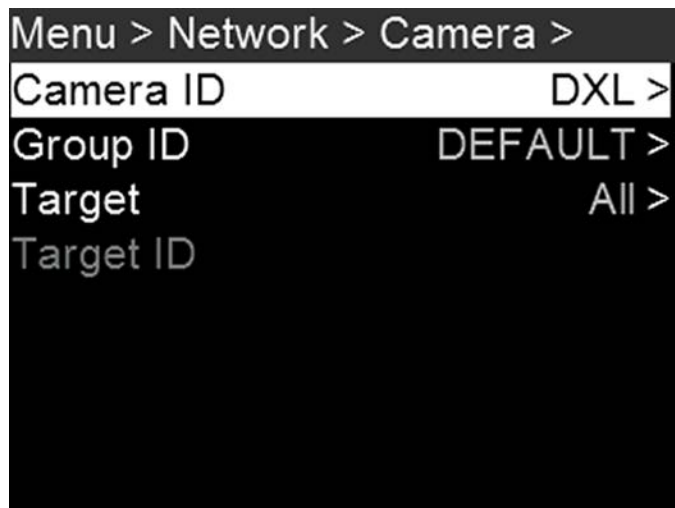

Figure: Camera Menu

SERIAL

To access the Serial menu, go to **Menu > Network > Serial**.

The camera can communicate to external devices via the GIG-E connector.

Select one of the following protocols from the **Ctrl Protocol** menu:

- ▶ None (Default)
- ▶ Element Technica
- ▶ 3ality SPC 7XXX
- ▶ RED Command Protocol
- ▶ Camera to Camera
- ▶ Preston

PANAVISION MILLENNIUM DXL2

MAINTENANCE

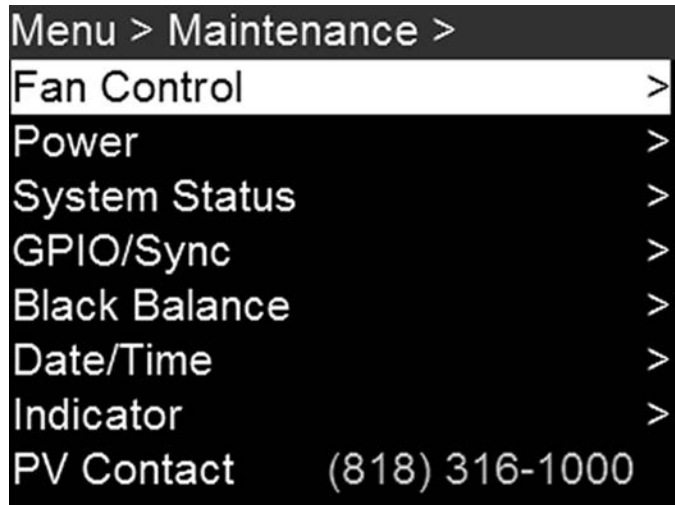

Figure: Maintenance Menu

FAN AND TEMPERATURE MANAGEMENT

To select a fan control mode, see the current camera temperatures (sensor and core), and see the current fan speeds, go to **Menu > Maintenance > Fan Control**.

The camera is controlled by complex thermal algorithms to ensure that the sensor and camera operate at safe temperatures. Each fan control mode affects the sensor temperature, sensor warm-up time, fan speed, and resulting fan noise.

When selecting a fan mode, first take into consideration how each fan mode behaves, and then select a fan mode that fits the needs of your project.

Regardless of sensor type and fan mode, you will get the best image quality by calibrating the sensor at the temperature you want to use for your shoot.

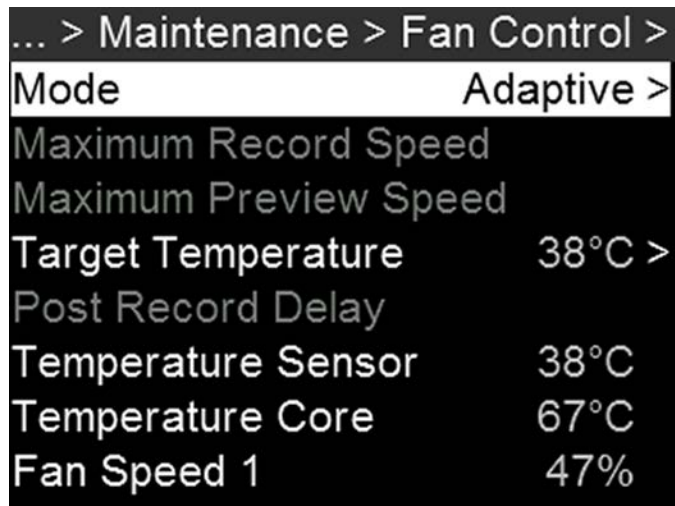

Figure: Fan Control Menu

PANAVISION MILLENNIUM DXL2

FAN CONTROL MODES

Select a fan control mode.

NOTE: After selecting a new fan setting, run the camera until the core temperature stabilizes, and then calibrate the sensor.

NOTE: Manual mode requires that you actively manage the sensor temperature, because this mode focuses on controlling fan speed and does not target a narrow sensor temperature range. Use the T/E status indicators as guides for proper temperature calibration.

NOTE: Maximum speeds are intended as target speeds only; actual fan speeds may be higher at times due to long recording times or high ambient temperatures.

ADAPTIVE (TARGET TEMPERATURE)

Adaptive is the default mode for the camera.

Select a Target Temperature and the fans self-adjust to maintain the selected temperature. The default Target Temperature is 39°C. After the camera reaches the Target Temperature, and if the ambient temperature remains constant, Adaptive mode results in a consistent fan speed and fan noise over time.

Targeting a higher temperature raises the sensor temperature, lengthens the sensor warm-up time, and lowers the fan speed. Targeting a lower temperature lowers the sensor temperature, shortens the sensor warm-up time, and increases the fan speed.

NOTE: The intent of Target Temperature is to set the sensor temperature so that you can then create a calibration map for that temperature.

NOTE: When the camera turns on, the Target Temperature is the temperature of the current calibration map, regardless of what the Target Temperature was before you turned off the camera. Setting a calibration map also overrides the Target Temperature. For more information, go to ["Sensor Calibration" on page 94](#).

ADAPTIVE PREVIEW QUIET RECORD

- ▶ **Record mode:** The camera uses Quiet fan mode. For more information, go to ["Quiet" below](#).
- ▶ **Standby mode:** The camera uses Adaptive fan mode. For more information, go to ["Adaptive \(Target Temperature\)" above](#).

QUIET

The fans self-adjust to maintain the lowest possible noise level in record and standby mode while still cooling the camera.

MANUAL

Select a speed for the fans in both record and standby modes. The fans self-adjust to maintain the selected speeds. The default Maximum Record Speed is 75% and the default Maximum Preview Speed is 75%. The range for both Maximum Record Speed and Maximum Preview Speed is 25–100%.

POST RECORD DELAY

Select the amount of time that it takes for the fan to switch from record to preview mode.

PANAVISION MILLENNIUM DXL2

TEMPERATURE AND FAN STATUS

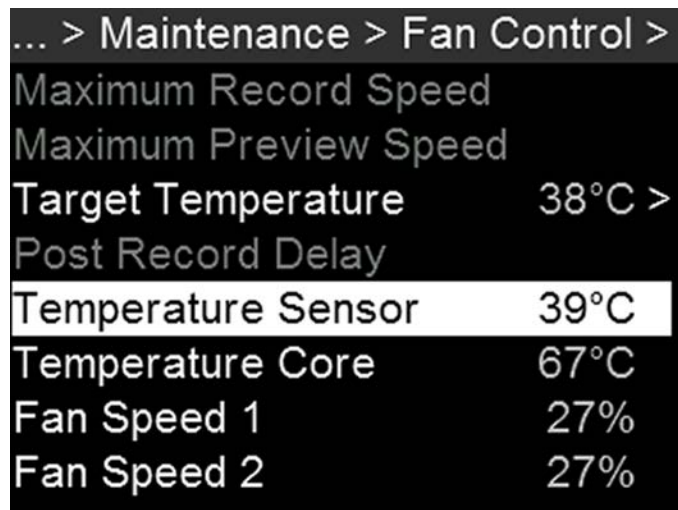

The screenshot shows a menu with the following items:

- ... > Maintenance > Fan Control >
- Maximum Record Speed
- Maximum Preview Speed
- Target Temperature 38°C >
- Post Record Delay
- Temperature Sensor 39°C
- Temperature Core 67°C
- Fan Speed 1 27%
- Fan Speed 2 27%

Figure: Temperature and Fan Statuses

The Fan Control menu displays the following statuses:

- ▶ **Temperature Sensor:** The current temperature of the sensor. This is the temperature directly affected by the Target Temperature setting.
- ▶ **Temperature Core:** The current temperature of the camera core.
- ▶ **Fan Speed 1:** The fan speed, measured as the percentage of the maximum speed of the fan.
- ▶ **Fan Speed 2:** The fan speed, measured as the percentage of the maximum speed of the fan.

PANAVISION MILLENNIUM DXL2

POWER MENU

The Power menu displays the power status of all attached power sources.

POWER IN

The power status displays for all attached power devices. The menu displays the voltage of the source or the relative percentage of the power left, as well as the time left, if applicable.

POWER OUT

The Power Out menu shows the status of the power-out ports on the camera. In this menu, you can also enable/disable each power-out port. The statuses are:

- ▶ **N/A**: The device is not present.
- ▶ **OK**: The power-out port is functional.
- ▶ **FAULT**: A short or overcurrent tripped the electronic fuse. Remove the device that is connected to the port, as it may be drawing too much power. Select **RESET** to clear the fault.

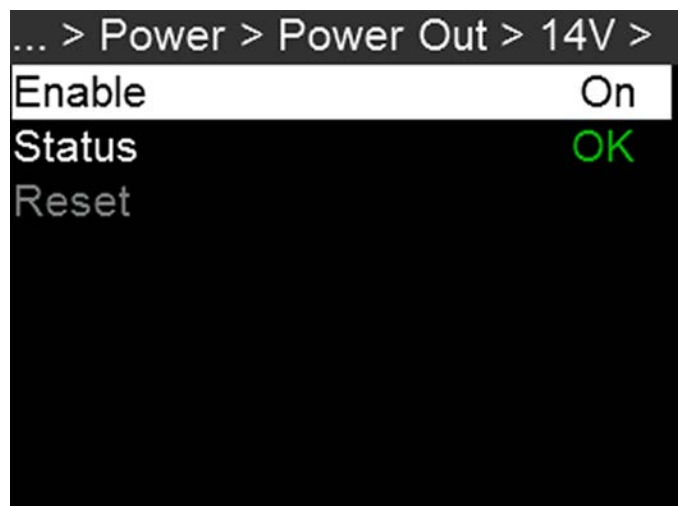

Figure: Power Out

PANAVISION MILLENNIUM DXL2

SYSTEM STATUS

The System Status menu displays key project and system information. To access the System Status menu, go to **Menu > Maintenance > System Status**.

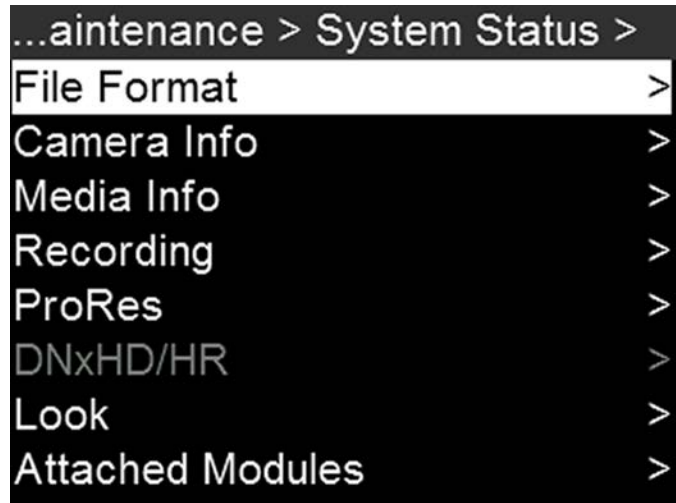

Figure: System Status

FILE FORMAT

Displays the file formats that are currently enabled. To change the file format, go to ["Select Record File Format" on page 50](#).

CAMERA INFO

Displays the following camera information:

- ▶ **Type:** Camera type.
- ▶ **Firmware Version:** Current firmware version.
- ▶ **PIN:** The personal identification number that is specific to your camera.
- ▶ **SVN Revision:** The current firmware number.
- ▶ **Runtime:** The number of hours that the camera has been turned on.

MEDIA INFO

Displays the following media information:

- ▶ Active Media
- ▶ Model Number
- ▶ Serial Number
- ▶ Firmware Version
- ▶ Size
- ▶ Size Available

PANAVISION MILLENNIUM DXL2

RECORDING

Displays the following recording information:

- ▶ Format
- ▶ Recording Frame Rate
- ▶ Project Time Base
- ▶ REDCODE

To change the recording information, go to ["Project Settings" on page 42](#).

PRORES

This status menu is available only if recording to an Apple ProRes codec is enabled.

Displays the following codec information:

- ▶ Video Codec
- ▶ Resolution
- ▶ Frame Rate

To change the recording information, go to ["Project Settings" on page 42](#).

DNXHD/HR

This status menu is available only if recording to an Avid codec is enabled.

Displays the following codec information:

- ▶ Video Codec
- ▶ Resolution
- ▶ Frame Rate

To change the recording information, go to ["Project Settings" on page 42](#).

LOOK

Displays the following information:

- ▶ Color Temperature
- ▶ Tint
- ▶ ISO

ATTACHED MODULES

Lists all attached modules.

PANAVISION MILLENNIUM DXL2

OTHER

Displays the following information:

- ▶ **Timecode Display Mode:** To change this, go to ["Timecode" on page 55](#).
- ▶ **Timecode Status**
- ▶ **Slate Camera Position:** To change this, go to ["Slate" on page 53](#).
- ▶ **Slate Camera ID:** To change this, go to ["Slate" on page 53](#).
- ▶ **Sync Status**
- ▶ **Genlock Status**
- ▶ **OLPF Type**
- ▶ **Calibration Temperature**
- ▶ **Calibration Integration Time**

CONNECTED RCP CLIENTS

Lists any RCP clients the camera is connected to.

PANAVISION MILLENNIUM DXL2

GPIO SYNC

To access the GPIO/Sync menu, go to **Menu > Maintenance > GPIO/Sync**.

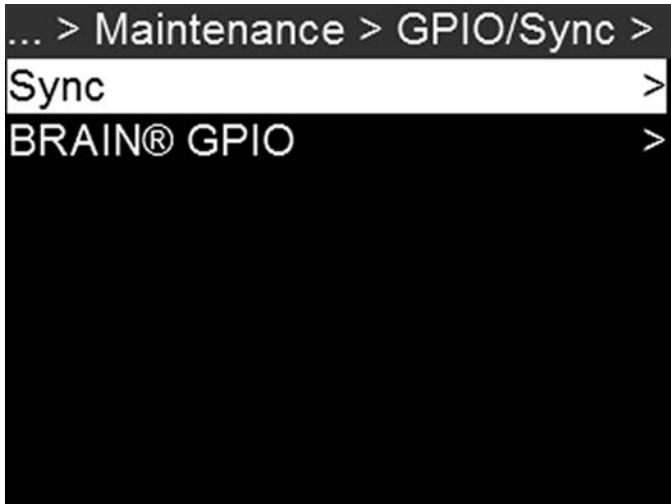

Figure: GPIO/Sync Menu

SYNC

Use the Sync menu to set up genlock and Motion Control (MoCo). For more information, go to "[Timecode, Genlock, Multi-Camera Setup](#)" on page 114.

SENSOR SYNC MODE

Sensor Sync Mode allows the shutter timing (scan start) to sync to an external signal.

- ▶ **Off:** Sensor runs at the current recording frame rate. This is the default option.
- ▶ **Genlock:** Sensor synchronizes with the incoming compatible genlock signal.
- ▶ **MoCo:** Each rising edge on the sync input triggers a frame to be captured.

GENLOCK SOURCE

Select a genlock input:

- ▶ BRAIN (Default)
- ▶ Rear Module

BRAIN GPIO

- ▶ **BRAIN GPI in High:** Map an action to the release of a trigger or off position of a switch.
- ▶ **BRAIN GPI in Low:** Map an action to the press of a trigger or on position of a switch.
- ▶ **GPO Function (Camera Output):** Select an option to configure the output for devices connected to the camera:
 - ▶ **Sync Out:** Provides an output sync signal to act as a shutter start tally.
 - ▶ **Recording Indicator Out:** Provides a signal when recording is in process.

For more information, go to [Input/Output Connectors](#).

PANAVISION MILLENNIUM DXL2

SENSOR CALIBRATION

Sensor calibration, also known as black balance, is a process during which the camera optimizes image quality by ensuring that pixel sensitivity remains consistent throughout the sensor. Calibrating the sensor generates a calibration map based on system and environment settings. After calibration, the sensor shows a uniform noise profile over the whole area without any falloffs on any side.

NOTE: Calibration maps are still available after performing a system restore.

WHEN TO CALIBRATE SENSOR

Calibration is required:

- ▶ After an extreme change in temperature (+/- 30°F or +/-15°C) from the current calibration map.
- ▶ After an extreme change in exposure time (+/- 1/2 sec) from the current calibration map.
- ▶ If either the T or E in the CAL: T/E indicator is not green.
- ▶ After each firmware upgrade.

To check the temperature/exposure of the current calibration file, go to **Menu > Maintenance > System Status > Other**.

BLACK BALANCE: CALIBRATE SENSOR AT CURRENT SETTINGS

The camera calibrates the sensor at the current exposure and temperature setting. You will need to re-calibrate the sensor after extreme changes in exposure and temperature. The process takes several minutes.

To calibrate the sensor, follow the instructions below:

1. Ensure that the camera reaches the temperature you want to use for your shoot.
2. Set the exposure to the exposure you want to use for your shoot.
3. Ensure that the sensor is as dark as possible.
 - ▶ Preferably, take off the lens, and install the front body cap.
 - ▶ If you cannot take off the lens, put a lens cap on the lens. (Not all lens caps completely block IR. Lens caps are made to protect the lens, not necessarily to block light.)
 - ▶ If possible, use a dark room.
 - ▶ Just closing the aperture is NOT sufficient.
4. Go to **Menu > Maintenance > Black Balance**.

PANAVISION MILLENNIUM DXL2

5. Select **Current Settings**.

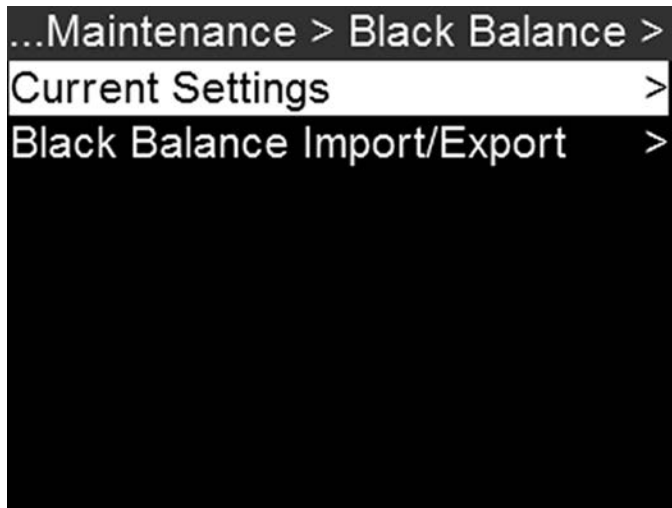

Figure: Select Current Settings

6. Select **Start**.
7. Select **OK** to continue. The system initializes and then makes multiple passes through the following phases of the calibration:
 - ▶ Capturing
 - ▶ Analyzing
 - ▶ Erasing
 - ▶ Programming
8. When the Calibration Successful dialog displays, select **OK** to complete the process.
The new calibration map is automatically selected.

PANAVISION MILLENNIUM DXL2

CALIBRATION MAP NAMING CONVENTIONS

Each calibration map has a unique name that uses the format described in the table below:

NAME	DESCRIPTION	EXAMPLE
Exposure	Current exposure; to set exposure, go to "Exposure/Shutter" on page 54	48
Sensor Temperature	Sensor temperature (Celsius); in the Lower Status Row, this is the number to the left of the forward slash (Temp: 34/35)	32C
Year	Year that the calibration map is created (yyyy)	2014
Month	Month that the calibration map is created (mm)	01
Day	Day that the calibration map is created (dd)	28
Time	Time according to the 24-hour clock in the camera (hhmmss)	122150

For example, a sequence of calibration maps may look like this:

1. 48_32C_20140128122150
2. 72_34C_20140128122858
3. 120_41C_20140128124306

NOTE: If you mount an SSD with calibration files to your computer, each calibration map displays as a sub-folder in a folder called Calibration. To save a calibration map to your hard drive, copy the entire sub-folder (for example, 48_32C_20140128122150) to your drive.

PANAVISION MILLENNIUM DXL2

CALIBRATION MANAGEMENT

NOTE: The camera can store a limited amount of calibration maps. (You may need to delete older maps in order to create new maps.) Calibration maps can also be transferred to SSD to be shared with other cameras.

To apply, export, and import calibration maps, go to **Menu > Maintenance > Black Balance > Black Balance Import/Export**.

- ▶ **In Camera:** The calibration maps that are saved internally on the camera:
 - ▶ **Factory:** This is the calibration map generated during the manufacturing process. (Default)
 - ▶ **All other:** The user-created calibration maps.
- ▶ **On Media:** The calibration maps that are on the SSD in the path shown (for example, S-SSD\calibration).



Figure: Import/Export Calibration Files

CALIBRATION MAP ACTIONS

- ▶ **Apply:** Apply the selected calibration map (if the calibration map is on the SSD, the camera applies the map temporarily, and does not import it into the camera).
- ▶ **Export:** Export selected calibration map from camera to SSD.
- ▶ **Export All:** Export all files from camera to SSD.
- ▶ **Import:** Import selected calibration map from SSD to camera.
- ▶ **Import All:** Import all files from SSD to camera.
- ▶ **Delete:** Delete the selected camera calibration map. You cannot delete the factory map.

PANAVISION MILLENNIUM DXL2

DATE/TIME

Use the Date/Time menu to reset the internal clock of the camera. The time and date are timestamps on R3D files when recording to an SSD. The camera uses the 24-hour clock convention (military time). For example, enter 2:35 p.m. as 14:35:00.

The date and time are saved when you close the Date/Time menu.



Figure: Date/Time

PANAVISION MILLENNIUM DXL2

INDICATOR

To access the Indicator menu, go to **Menu > Maintenance > Indicator**.

- ▶ **Enable Sounds:** Select to enable sounds. Then select sounds for the following actions:
 - ▶ Record Start
 - ▶ Record Stop
 - ▶ Tag Still Frame
- ▶ **EVF Tally Light:** Enable the EVF Record Tally LED on the EVF to illuminate red when recording.
- ▶ **SSD Tally Light:** Enable the Record Tally LED on the media bay to illuminate red when recording. For more information, go to "[Left Side \(Operator Side\) LEDs](#)" on page 13.

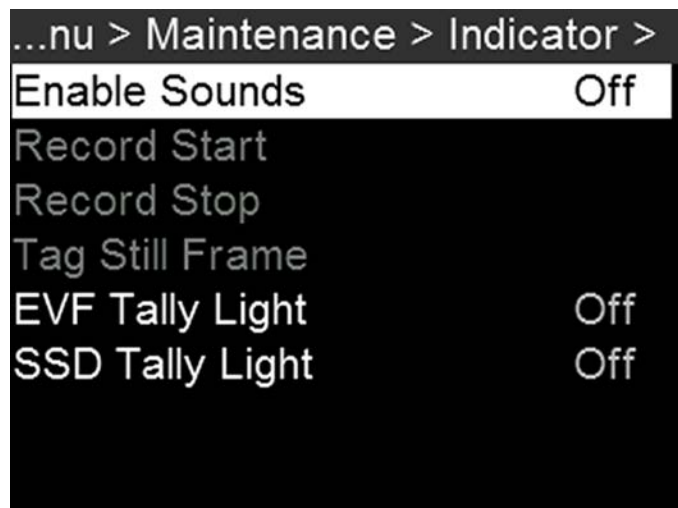

Figure: Indicator Menu

PV CONTACT

This is the phone number for the Panavision office in Woodland Hills, CA: (818) 316-1000.

PANAVISION MILLENNIUM DXL2

SAVE A LOG FILE

A log file is a detailed text file of the processes and operations performed by the camera. If you contact support, you may be asked to send a log file.

To save a log file, follow the instructions below:

1. Ensure that an SSD is properly mounted to the camera.
2. Go to **Menu > Maintenance > Save Log**.

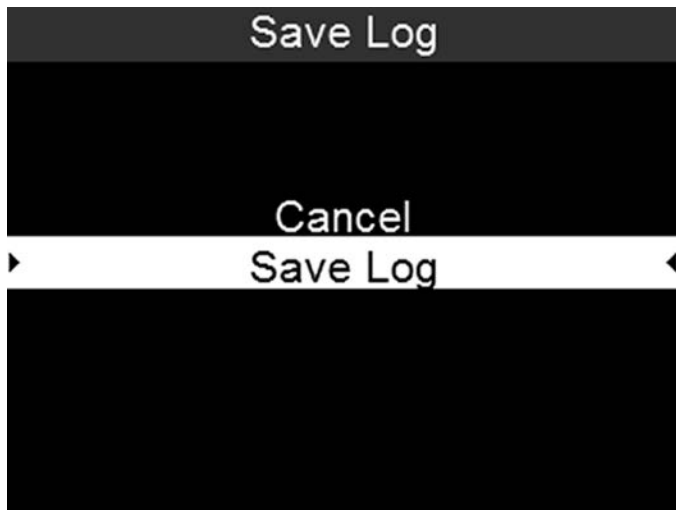

Figure: Save Log

3. Select **Save Log**.

The log file is saved as a *.txt file in the SSD root directory.

NOTE: The camera automatically saves a log file when it is turned off properly and an SSD is mounted.

PANAVISION MILLENNIUM DXL2

CAMERA DEFAULT

RESET DEFAULTS

Reset Defaults changes all settings to the factory default values. To perform a Reset Defaults, follow the instructions below:

1. Go to **Menu > Maintenance > Camera Defaults > Reset Defaults**.

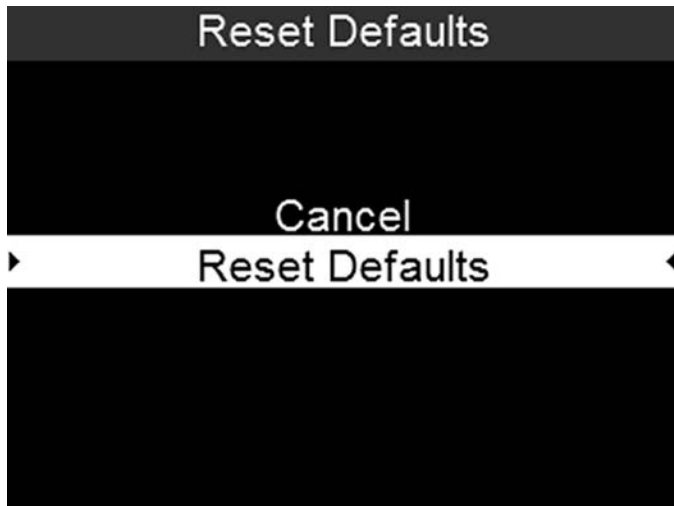

Figure: Reset Defaults

2. Select **Reset Defaults**.
3. Select **YES** on the screen that asks you to confirm the action.
The camera turns off.
4. Turn on the camera.

PANAVISION MILLENNIUM DXL2

WIPE CAMERA

Wipe Camera deletes all user settings, including: calibration files, overlays, presets, and LUTs. Wipe Camera restores all factory defaults.

1. Go to **Menu > Maintenance > Camera Defaults > Wipe Camera**.

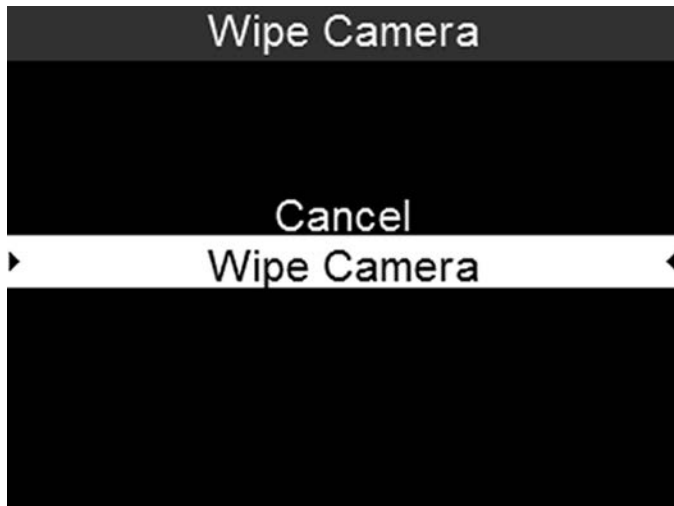

Figure: Wipe Camera

2. Select **Wipe Camera**.
3. Select **YES** on the screen that asks you to confirm the action.
The camera turns off.
4. Turn on the camera.

PANAVISION MILLENNIUM DXL2

UPGRADE

If there is an upgrade package on a mounted SSD, you can initiate a firmware upgrade from within the menu:

1. Go to **Menu > Maintenance > Upgrade**.
2. Select **Camera**.
3. Select **Upgrade Camera Firmware**.

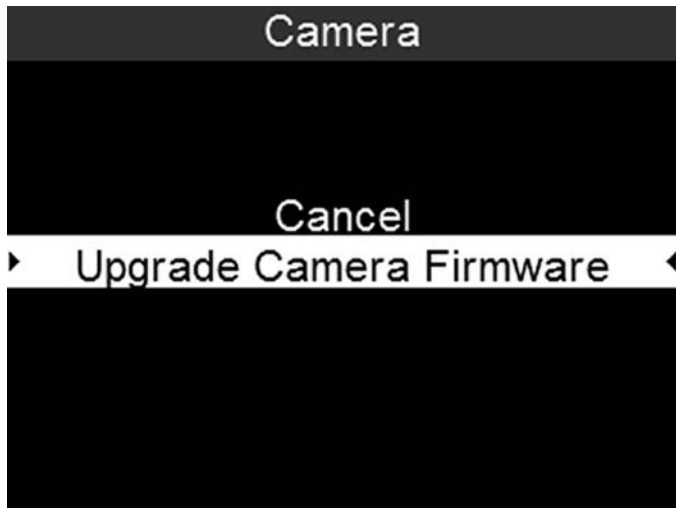

Figure: Upgrade Camera Firmware

PLAYBACK

NOTE: Clips captured in RAW with a 3D LUT applied during recording will play back with the same LUT applied; the LUT cannot be changed for playback. 3D LUTs cannot be applied in Playback mode for non-RAW clips.

To view clips from the SSD, follow the instructions below:

- ▶ From the Home Page, select **Playback**.
- ▶ Use the Navigation Wheel or the selection keys to select the clip you want to view.
 - ▶ **First Clip:** Goes to the first clip on the SSD.
 - ▶ **Last Clip:** Goes to the last clip on the SSD.
- ▶ Select **Play** (the lower-right selection key) or **Enter**.

PANAVISION MILLENNIUM DXL2

PLAYBACK STATUS BAR

Displays the progress of the clip during playback. Use the selection keys to control playback, as described in the table below.

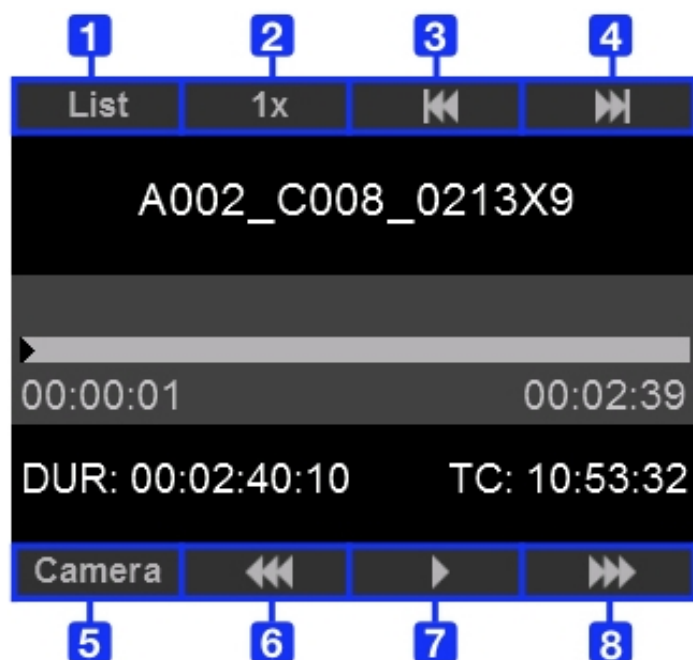

Figure: Playback Status Bar

#	CONTROL	DESCRIPTION
1	List	Returns to the list of clips.
2	Speed	Indicates the playback speed. Not an operable key.
3	Previous clip	Goes to the previous clip.
4	Next clip	Goes to the next clip.
5	Camera	Exits Playback mode.
6	Reverse	Adjusts the playback speed (from -1x to -16x) when playing backward through the clip.
7	Play/Pause	Pauses and resumes playback.
8	Forward	Adjusts the playback speed (from 1x to 16x) when playing forward through the clip.

EXIT PLAYBACK MODE

Perform one of the following actions to exit Playback mode:

- ▶ Press **Camera**.
- ▶ Press **Menu**.
- ▶ Press **Record**. (You can also press any button mapped to Record to exit Playback mode.)

AUDIO SYSTEM

AUDIO OVERVIEW

The camera has two (2) integrated dual channel digital stereo microphones that record uncompressed audio at 24-bit 48 kHz. These microphones offer you the ability to capture scratch-track audio.

Most controls in the Audio menu (**Menu > Audio**) are only applicable when an audio module is attached.

Input signals are routed via a high-quality pre-amplifier to achieve the desired recording levels and maximize dynamic range.

Audio data is synchronized with video and timecode and embedded in the R3D[®] file.

Audio is also embedded in any HD-SDI output connected to the camera.



Figure: Audio Menu

PANAVISION MILLENNIUM DXL2

CONTROL

To adjust the input and pre-amplifier, go to **Menu > Audio > Control**.

CHANNEL SOURCES AND NAMES

You can rename each audio channel, and each name can be any alphanumeric combination, up to six (6) characters. The default channel names are Ch1, Ch2, Ch3, and Ch4. The channel names display in the Audio Meter, but are not included in the clip metadata.

1. To set up the audio channels, go to **Menu > Audio > Control**.
2. Select the channels you want to set up: **Channel 1/2** or **Channel 3/4**.

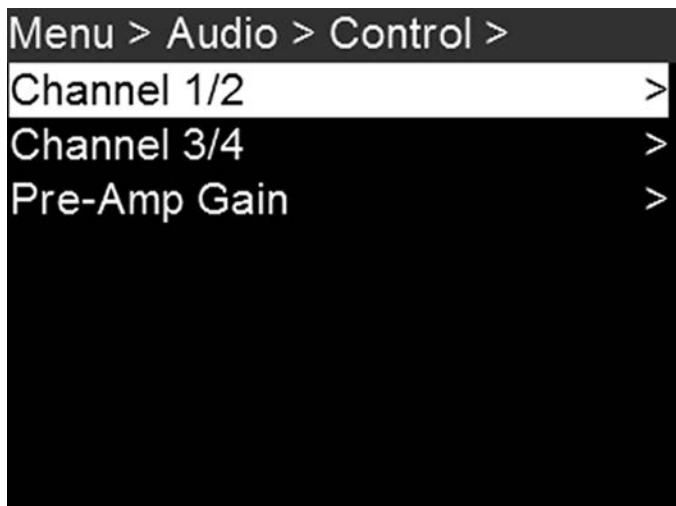

Figure: Control Menu

3. Set the channel source:
 - A. Select **Ch X/X Source**.
 - B. Select a source: **None** or **Camera Internal**.

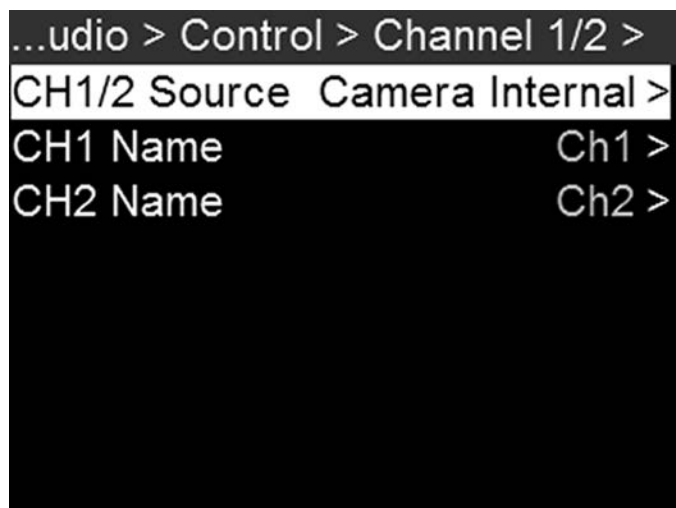

Figure: Select Audio Source for Channel

- C. Press **Enter**.

PANAVISION MILLENNIUM DXL2

4. Set the channel name:
 - A. Select **CHX Name**.

NOTE: Select **1/2** or **2/2** in the bottom right of the screen to toggle between the first and second page of menu options.
 - B. For each character available, use the **Scroll Wheel** to select a character. Turn counterclockwise to cycle through the characters in this order: uppercase alphabet, lowercase alphabet, numbers 0–9.
 - C. Press the **Left** and **Right** keys to move to the previous or next character, respectively.
 - D. Select **Delete** to delete a character.
 - E. Select **Insert** to insert a character (up to 6 characters available); selecting insert re-starts at A.
 - F. Select **Clear** to clear the name.
 - G. Select **Begin** to move the cursor to the first character.
 - H. Select **End** to move the cursor to the last (sixth) character.
 - I. Once you have selected the name you want, press **Enter**.

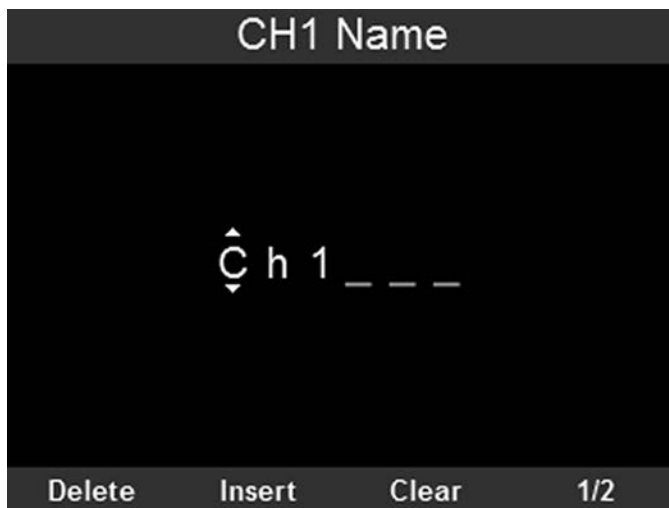

Figure: Select Channel Name

PANAVISION MILLENNIUM DXL2

PRE-AMP GAIN

To adjust amplification levels, follow the instructions below:

1. Go to **Menu > Audio > Control > Pre-Amp Gain**.

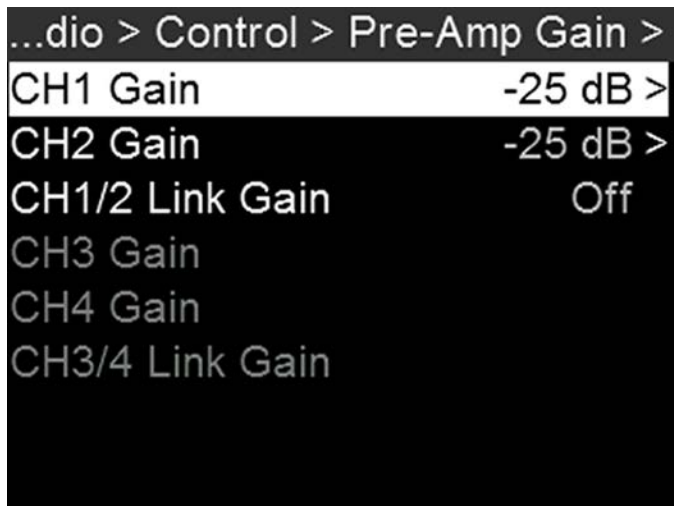

Figure: Pre-Amp Gain Menu

2. Select which channel you want to adjust: CH1, CH2, CH3, CH4.
3. Use the **Scroll Wheel** to select a value.
4. Press **Enter** to set the value as the Pre-Amp Gain.
5. To link a pair of channels together:
 - A. Use the **Scroll Wheel** to highlight **Ch1/2 Link Gain** or **Ch3/4 Link Gain**.
 - B. Press **Enter** to toggle the link on/off.

PANAVISION MILLENNIUM DXL2

MONITOR MIX

The camera features a digital audio mixer that controls audio settings for external HD-SDI monitors that support audio. The mixer controls volume and stereo settings. The mixer DOES NOT affect audio embedded in the R3D file. Monitor Mix offers these settings:

- ▶ **Pan:** Adjust the stereo mix for the channel. Range is -100 (Full Left) to 100 (Full Right). The default for Channel 1 and Channel 3 is -100. The default for Channel 2 and Channel 4 is 100.
- ▶ **Volume:** Adjust volume for the channel. Range is 0% to 100%. The default for each active channel is 100%. Channel 3 and Channel 4 are active only when there is audio input.

SET UP PAN AND VOLUME

1. Go to Menu > Audio > Mix > Monitor Mix.

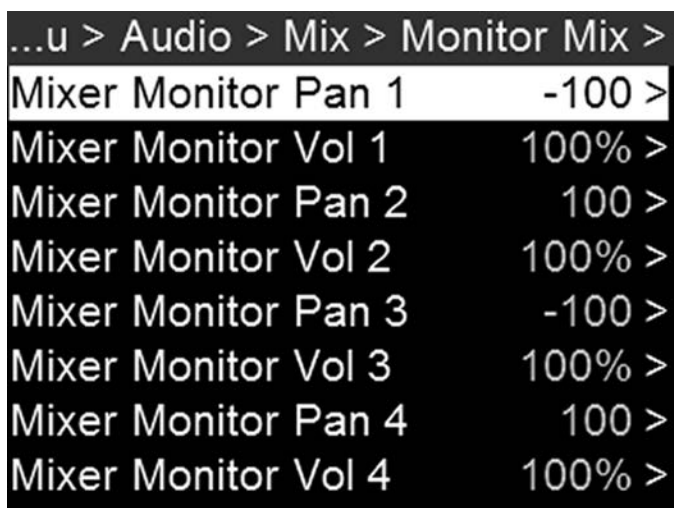

Figure: Monitor Mix Menu

PANAVISION MILLENNIUM DXL2

2. To set up a channel's stereo setting:
 - A. Select **Mixer Monitor Pan** for the channel you want to set up.
 - B. Use the **Scroll Wheel** to highlight the setting you want.
 - C. Press **Enter**.

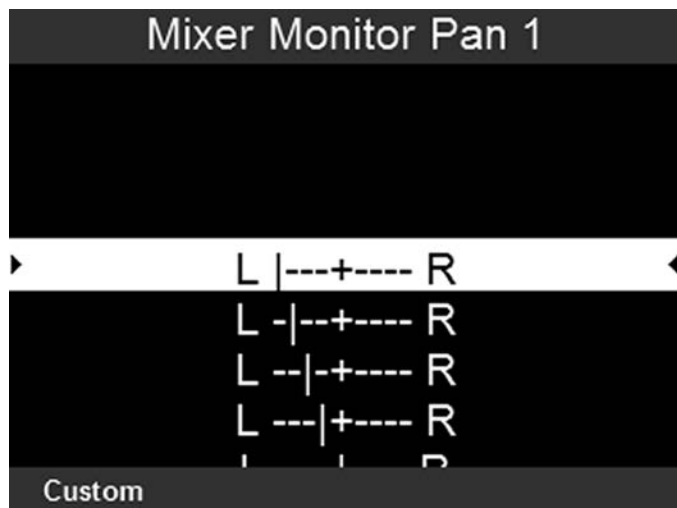

Figure: Set Up Channel Stereo Setting

3. To set up a channel's volume:
 - A. Select **Mixer Monitor Vol** for the channel you want to set up.
 - B. Use the **Scroll Wheel** to highlight the setting you want.
 - C. Press **Enter**.

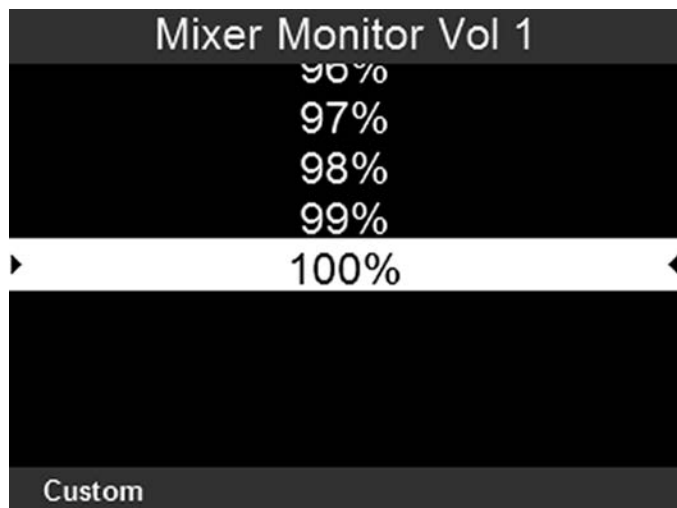

Figure: Set Up Channel Volume

PANAVISION MILLENNIUM DXL2

AUDIO OUTPUT

The SDI ports output two (2) channels of 24-bit 48 KHz uncompressed, embedded digital audio. For information on how to set up and mix the stereo channels, go to ["Monitor Mix" on page 110](#). To monitor audio via HD-SDI, the third-party monitor must support audio.

AUDIO METER (VU METER)

The Audio Meter displays on the Audio Page. For more information, go to ["Home Page Presets" on page 76](#).

INCOMING AUDIO CHANNELS

When you select Input as the VU Meter Source, the Audio Meter displays the incoming audio channels (default). For more information, go to ["VU Meter" on page 64](#). Channel 1 and Channel 2 are the default channels, correlating with the MIC-1 and MIC-2 inputs on the camera. Channel 3 and Channel 4 are greyed out unless the camera detects audio input.

The channel names selected in the Audio menu determine the channel names displayed in the Audio Meter. For more information, go to ["Channel Sources and Names" on page 107](#).

The Audio Meter shows the incoming audio signal when a source is selected, even if the channel is not recorded.

OUTGOING AUDIO

When you select Output as the VU Meter Source, the Audio Meter displays the Monitor Mix levels. For more information, go to ["VU Meter" on page 64](#).

When recording to an external device, use the Output levels to help accurately monitor recorded audio.

PANAVISION MILLENNIUM DXL2

AUDIO METER LEVELS

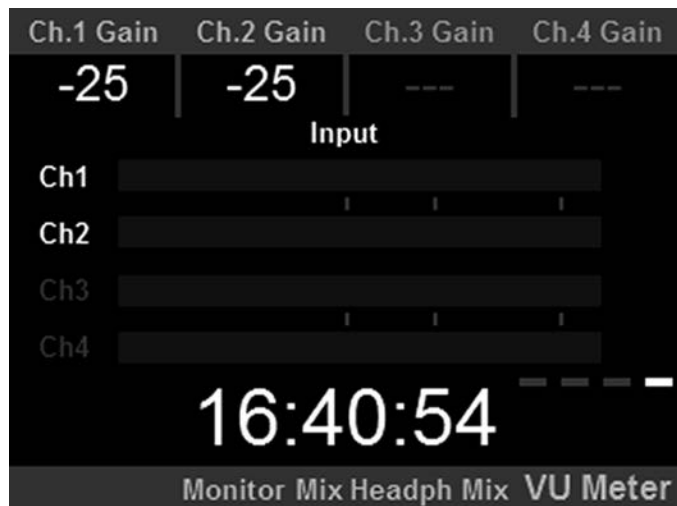

Figure: Audio Meter

The camera updates the Audio Meter 12 times per second with the maximum signal from the last 1/12 of a second period. The range of the Audio Meter is -52 dBFS to 0 dBFS.

The lines and colors indicate danger of clipping, as described in the table below:

LINE	DBFS	DESCRIPTION
First line (far left border)	-52 dBFS	Audio is not clipping
Second line	-20 dBFS	Audio is not clipping
Third line	-12 dBFS	Audio close to clipping
Fourth line	-2 dBFS	Audio is clipping
Fifth line (far right border)	0 dBFS	Audio is clipping (if signal exceeds -1 dBFS, the whole bar is red)

NOTE: In the American broadcast and post production systems, -20 dBFS roughly corresponds to 0 VU and 4 dBu. In a digital system, dBu is an approximation; the correct unit for digital audio levels is dBFS.

AUDIO DURING PLAYBACK

The camera plays all recorded channels during playback, and automatically unmutes any muted audio outputs.

TIMECODE, GENLOCK, MULTI-CAMERA SETUP

This chapter describes timecode, genlock, and multi-camera operations such as 3D and array setup.

TIMECODE

Timecode is a numeric sequence based on SMPTE 12M that aids in the management and synchronization of footage and audio. Timecode is embedded in recorded RAW files, QuickTime® files (if recording an Apple® ProRes codec), and MXF files (if recording an Avid® codec) as metadata and in HANC metadata provided by the HD-SDI monitor output. The camera can generate timecode on its own or can receive and sync to timecode generated by an external source.

Timecode displays on the side UI panels, SDI overlays and is embedded as metadata. Timecode is represented as an eight (8) digit sequence (HH:MM:SS:FF), where:

- ▶ **HH:** Hours
- ▶ **MM:** Minutes
- ▶ **SS:** Seconds
- ▶ **FF:** Frames

NOTE: Timecode is most accurate and effective when coupled with genlock. For more information, go to "Genlock" on [page 116](#).

SET UP INTERNAL TIMECODE

To set up and adjust timecode generated by the camera, follow the instructions below:

1. Go to **Menu > Project Settings > Timecode**.
2. Select the desired **Display Mode**.
3. Set **Source** to **RTC**.
4. If applicable, enable **LTC Out** (Linear Timecode Out).

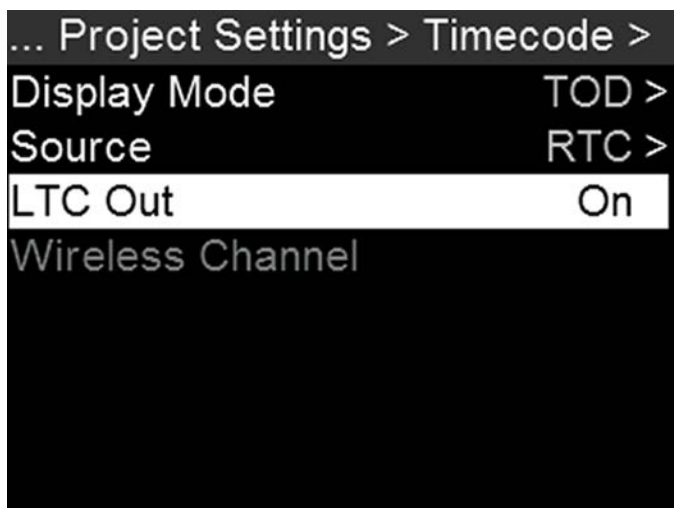

Figure: Set Up Internal Timecode

PANAVISION MILLENNIUM DXL2

OUTPUT TIMECODE

The camera can output a timecode signal to an external device or to a slaved camera.

1. Follow the instructions in ["Set Up Internal Timecode" on the previous page](#) to set up internal timecode.
2. Use a cable to connect the TIMECODE port on the camera to another device.

INPUT EXTERNAL TIMECODE

To input timecode generated by an external device, follow the instructions below:

1. Use a cable to connect the TIMECODE port on the camera to another device.
2. Go to **Menu > Project Settings > Timecode**.
3. Select the desired **Display Mode**.
4. Set **Source** to **External**.

The TC indicator turns green when an external timecode source is locked.

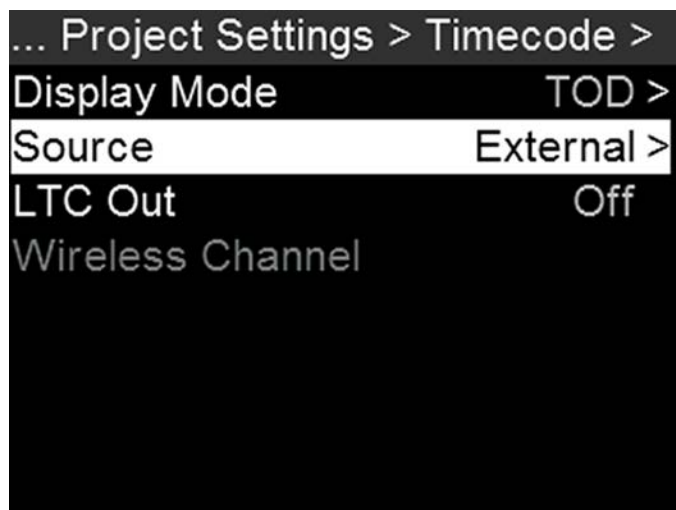

Figure: Use External Timecode

SYNC TIMECODE WITH ACN

The camera can connect to the wireless Ambient communication and synchronization network (ACN™). To connect to ACN, follow the instructions below:

1. Go to **Menu > Project Settings > Timecode**.
2. Set **Source** to **ACN**. For more information, go to ["Timecode" on page 55](#).
3. In the Timecode menu, set the **Wireless Channel** to the same wireless channel as the device. For more information, go to ["Wireless Channel" on page 55](#).

PANAVISION MILLENNIUM DXL2

GENLOCK

Generator locking (genlock) is a tri-level signal used to synchronize video and audio systems. Genlock is based on SMPTE 296M and 274M. There are two (2) important genlock sync modes:

- ▶ Monitor Sync
- ▶ Sensor Sync

MONITOR SYNC

Monitor Sync occurs when an incoming genlock signal is compatible with the monitor output frequency. Monitor Sync is achievable even if the camera is using another form of synchronization to sync the camera sensor.

1. Use a BNC cable to connect the **GENLOCK** port on the camera to genlock device.
2. Set up the frequency for the HD-SDI output (select **Auto** to automatically match the HD-SDI output to the current Project Time Base). For more information, go to "[Frequency](#)" on page 59.

Monitor Sync is achieved automatically when an incoming genlock signal is compatible with the monitor output frequency. When Monitor Sync is achieved, the **GEN** indicator illuminates green.

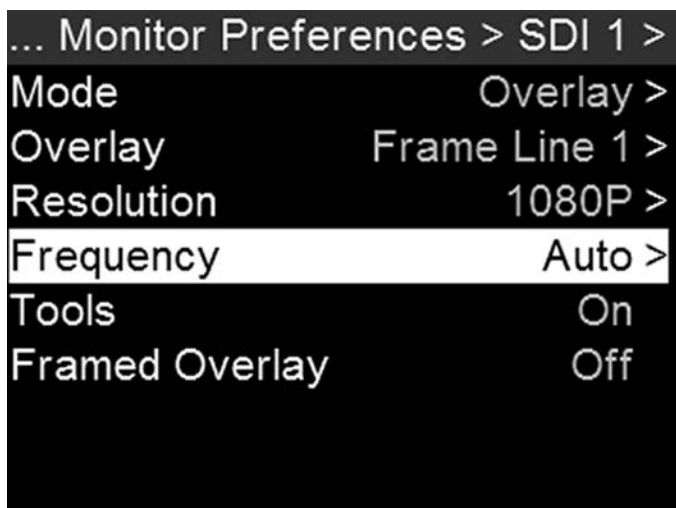

Figure: Set Frequency for Monitor

PANAVISION MILLENNIUM DXL2

SENSOR SYNC

Sensor Sync is achieved when an incoming genlock signal is compatible with the monitor output frequency, project time base, and recording frame rate. In Sensor Sync mode, sensor timing is locked to the genlock signal. Sensor Sync requires the following synchronized settings:

SETTING	MENU LOCATION PATH
Genlock signal frequency	N/A; external genlock device
HD-SDI monitor output frequency	Menu > Monitoring > Monitor Preferences > select monitor
Project Time Base	Menu > Project Settings > Timebase
Recording Frame Rate	FPS (from home page)

To set up and enable Sensor Sync Mode, follow the instructions below:

1. Use a BNC cable to connect the **GENLOCK** port on the camera to genlock device.
2. Go to **Menu > Maintenance > GPIO/Sync > Sync**.
3. Set **Sensor Sync Mode** to **Genlock**.

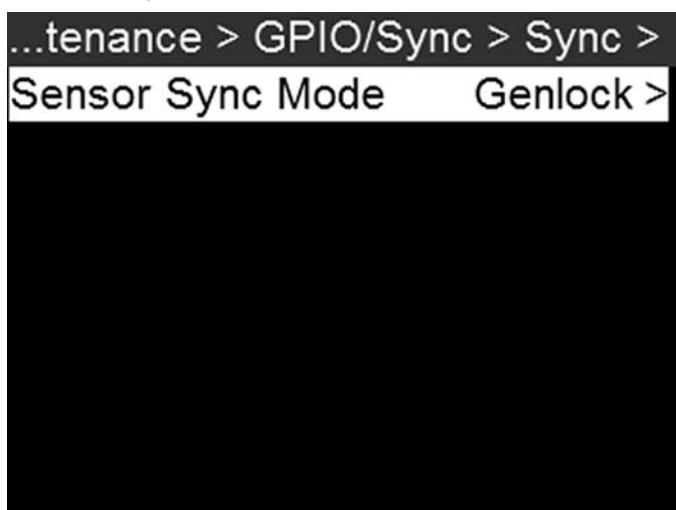

Figure: Set Sensor Sync Mode to Genlock

4. Set up the frequency for the HD-SDI output (select **Auto** to automatically match the HD-SDI output to the current Project Time Base). For more information, go to "[Frequency](#)" on page 59.

The **GEN** indicator turns green when a compatible genlock signal is present and genlock is enabled. The **SYNC** indicator turns green when Sensor Sync is achieved.

MASTER/SLAVE OPERATION

NOTE: The Master camera controls metadata and basic camera parameters of the Slave cameras. Any other setting changes required by the Slave cameras must be made before recording.

This section describes operation in Master/Slave configuration and clip naming conventions for clips recorded on those cameras. Master/Slave is the most common configuration for Stereo/3D productions.

When cameras are operated in Master/Slave configuration, you can perform the following operations:

- ▶ **Power:** Turn off the Master camera to turn off both cameras.
- ▶ **Record:** Press the **PWR/REC** key on the Master camera to start/stop recording on both cameras.
- ▶ **Change settings:** Change settings on the Master camera to change settings on the Slave camera.

For a Master/Slave configuration to function, the cameras must have the same:

- ▶ Firmware version
- ▶ Project time base
- ▶ Recording frame rate
- ▶ Sensor

PANAVISION MILLENNIUM DXL2

SET UP MASTER/SLAVE OPERATION

1. Use a Gig-E cable to connect the **GIG-E** port on one camera to the **GIG-E** port on the other camera.
2. On the Master camera, follow the instructions below:
 - A. Go to **Menu > Network > Camera**.
 - B. Type a name for the camera (Example: CAM A, LEFT, MASTER, etc) in the **Camera ID** field.
 - C. Set **Target** to **All**.

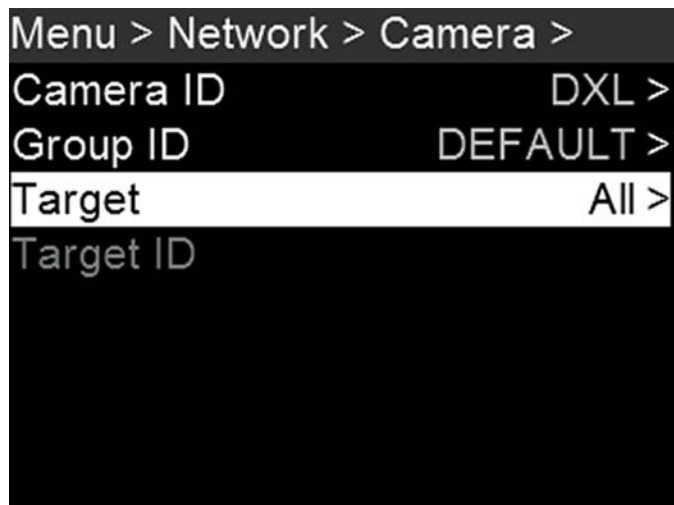

Figure: Set Target to All

- D. Go to **Menu > Network > Ethernet**.
- E. Enable **Camera to Camera**.

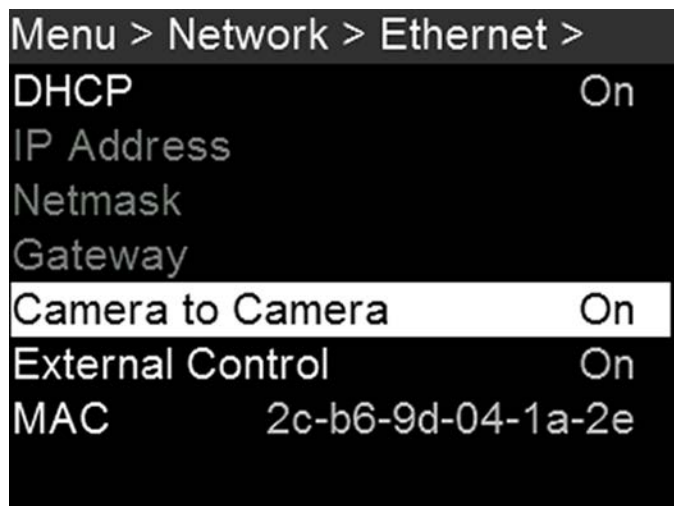

Figure: Set Target to All

PANAVISION MILLENNIUM DXL2

3. On the Slave camera(s), follow the instructions below:

A. Go to **Menu > Network > Camera**.

B. Type a name for the camera (Example: CAM B, RIGHT, SLAVE, etc) in the **Camera ID** field.

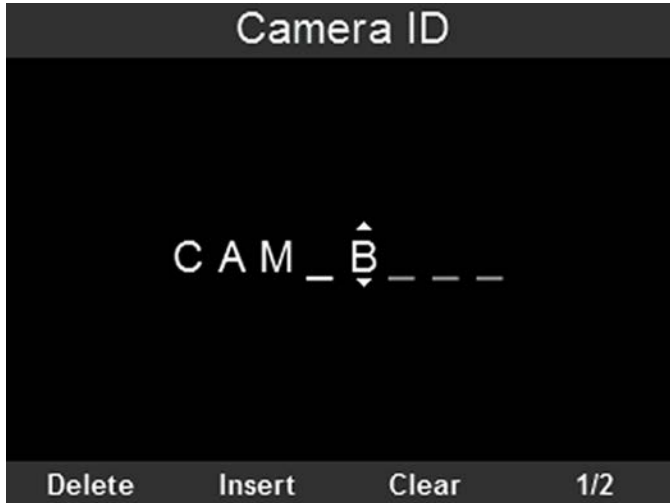

Figure: Set Target to All

C. Set Target to None.

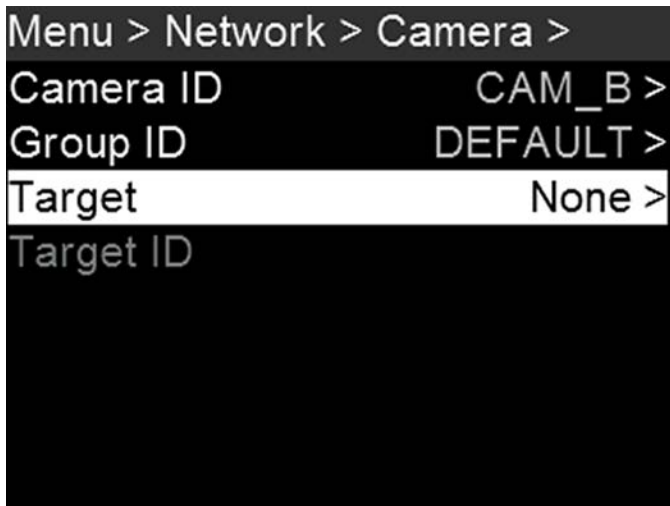

Figure: Set Target to All

D. Go to **Menu > Network > Ethernet**.

PANAVISION MILLENNIUM DXL2

E. Enable **Camera to Camera**.

The LAN indicator illuminates green.

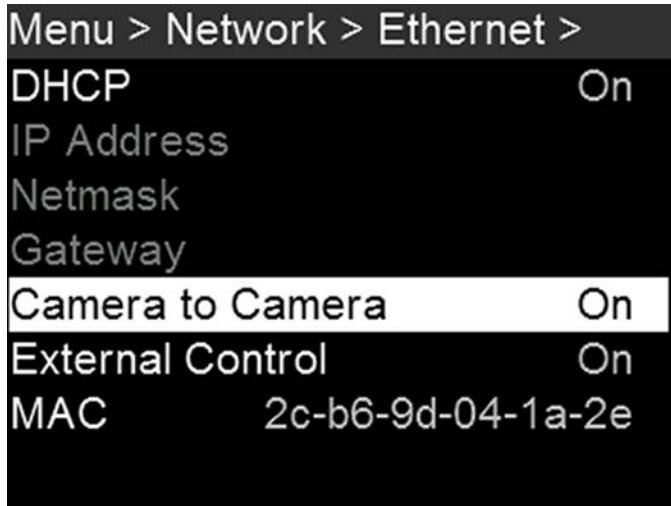

Figure: Set Target to All

NOTE: Cameras can also be set up in a Master/Master configuration. To set up Master/Master, set **Target** to **All** on both cameras, allowing either camera to make changes and control record start/stop.

SET REEL NUMBER, CAMERA ID, AND CAMERA POSITION

NOTE: Camera ID and Camera Position settings can also be found at **Menu > Project Settings > Slate**.

To prepare media and slate settings for a Master/Slave or Stereo/3D production, follow the instructions below:

1. On both Master and Slave cameras, go to **Menu > Media > Quick Format** or **Full Format**.
2. On both Master and Slave cameras, select the desired **Reel Number** and **Camera ID** settings. The Reel Number and Camera ID settings on both cameras should match.
3. On the Master camera, change the **Camera Position** to **Left**, representing "left eye".
4. On the Slave camera, change the **Camera Position** to **Right**, representing "right eye".
5. On both cameras, select **Format Media** to format media and set the Reel Number, Camera ID, and Camera Position settings.

PANAVISION MILLENNIUM DXL2

MULTI-CAMERA CLIP NAMING CONVENTIONS

This section describes automatic camera-generated clip naming conventions based on slate settings. Cameras use the Reel No, Cam ID, and Cam Pos settings to generate a custom clip name.

For example, if you have two (2) cameras in Master/Slave configuration and format media on both cameras with the following settings:

CAMERA	REEL NUMBER	CAMERA ID	CAMERA POSITION
Master	1	S	Left
Slave	1	S	Right

The first clip recorded by this Master/Slave camera configuration is:

- ▶ **Master:** S001_L001_0503B6.R3D
- ▶ **Slave:** S001_R001_0503R7.R3D

NOTE: B6 and R7 are examples of camera-generated wildcard characters.

NOTE: If both cameras are assigned the same Camera Position—Left, Center, or Right—the recorded clips will have the same filename structure, with the exception of the camera-generated wildcard characters. For example:

- ▶ **Master:** A001_C001_0503B6.R3D
- ▶ **Slave:** A001_C001_0503R7.R3D

NOTE: Reel Number, Camera ID, and Camera Position can be set when formatting media.

SET UP STEREO/3D CONFIGURATION

This section describes basic procedures for connecting two (2) cameras in a Master/Slave configuration for 3D operation.

NOTE: When providing the signals to a Stereo Image Processor (SiP) for verifying 3D alignment, set the HD-SDI monitor output on both cameras to have the same overlay configuration.

NOTE: For genlock to function correctly, the cameras must be on the same firmware version, and must be using the same project time base and recording frame rate.

To set up a Stereo/3D setup, follow the instructions below.

1. On both cameras, set the project time base and recording frame rate.
2. On both cameras, follow the instructions in ["Sensor Sync" on page 117](#) to achieve Sensor Sync genlock status.
The **GEN** and **SYNC** indicators in the Lower Status Row illuminate green.
3. Follow the instructions in ["Set Up Master/Slave Operation" on page 119](#) to set Master and Slave camera settings.
4. On both cameras, follow the instructions in ["Set Reel Number, Camera ID, and Camera Position" on the previous page](#) to set up media and camera settings.

PANAVISION MILLENNIUM DXL2

CAMERA ARRAY

SET UP A CAMERA ARRAY

NOTE: For genlock to function correctly, the cameras must be on the same firmware version, and must be using the same project time base and recording frame rate.

You can sync more than two (2) cameras for applications and productions that require a camera array. To set up a camera array, you need a 1000Base-T gigabit Ethernet router.

To set up a camera array, follow the instructions below:

1. On each camera, go to **Menu > Network > Camera** and set the following:
 - A. Set **Target** to **All**.
 - B. Enter a matching name in the **Group ID** field. All cameras must have the same Group ID name.
2. On each camera, go to **Menu > Network > Ethernet**, and set the **DHCP**, **Camera to Camera**, and **External Control** options to **On**.
3. Follow the instructions in "[Sensor Sync](#)" on [page 117](#) to connect each camera to the genlock device.
The **GEN** and **SYNC** indicators in the Lower Status Row illuminate green.
4. Follow the instructions in "[Set Up Master/Slave Operation](#)" on [page 119](#) to set Master and Slave camera settings. Instead of using the Master/Slave Gig-E Cable, connect each camera to the router.
5. On each camera, follow the instructions in "[Set Reel Number, Camera ID, and Camera Position](#)" on [page 121](#) to prepare media and camera settings.

COMPATIBLE TIMECODE DEVICES

The Panavision Millennium DXL2 is compatible with all Ambient timecode devices, as well as the following devices from other manufacturers. Additional timecode devices may be compatible, but have not yet been tested.

- ▶ Denecke SB-3 Syncbox Time-Code Generator
- ▶ Sound Devices 788T
- ▶ Sound Devices 744
- ▶ Sound Devices PIX-240
- ▶ Zaxcom Nomad 12
- ▶ Zaxcom ZFR100
- ▶ Zaxcom ZFR200

PANAVISION MILLENNIUM DXL2

COMPATIBLE GENLOCK DEVICES

The following genlock devices are compatible with the camera. Additional genlock devices may be compatible, but have not yet been tested.

- ▶ AJA® GEN10 HD/SD/AES Sync Generator with Universal Power Supply
- ▶ Ambient ACL 202CT
- ▶ Ambient ACL 203
- ▶ Ambient ACL 204
- ▶ Denecke SB-T
- ▶ Evertz Master Clock 5600MSC

NOTE: Ensure that your genlock device provides a full-strength genlock signal to each camera. Splitting a genlock signal weakens it, which may compromise the sync between cameras.

UPGRADE CAMERA FIRMWARE

VERIFY CURRENT CAMERA FIRMWARE

To see the firmware version that is currently installed on your camera, go to **Menu > Maintenance > System Status > Camera Info**. A higher number reflects a later release.

UPGRADE CAMERA FIRMWARE

Install the most recent firmware. Unless otherwise specified in the release notes, you do not need to upgrade to any firmware in between your current version and the most recent version available online.

1. Connect a Panavision MINI-MAG SSD to your computer.
2. Unzip the firmware zip file.
3. Copy the **force_upgrade** folder and its contents to the top level of the SSD directory.
4. Eject or unmount the SSD, and then remove the SSD.
5. Ensure that the camera is turned off.
6. Insert the SSD with the force_upgrade folder into your camera.
7. Turn on the camera.

The upgrade runs automatically.

During upgrade, the fans run at high speed and the PWR and REC LEDs flash green. After approximately 15 seconds, the LEDs stop flashing and the camera turns off. Nothing displays on the external monitors during the upgrade.

8. After the camera turns off, remove the SSD and wait 10 seconds.
9. Turn on the camera.

The camera may take 30 seconds or longer to upgrade all of the attached modules. During this time the PWR and REC LEDs flash green and nothing displays on the external monitors.

10. Verify that the firmware version listed matches the firmware version that you downloaded. For more information, go to ["Verify Current Camera Firmware" above](#).
11. Reformat the SSD before recording.

CAMERA SYSTEM MAINTENANCE

All Panavision products are designed for rugged durability, but precision instruments demand proper care. Follow the instructions in this chapter to clean, maintain, and store your devices.

WARNING: DO NOT rinse or immerse the camera or other accessories in water. Keep dry at all times.

WARNING: DO NOT use soaps, detergents, ammonia, acetone, alkaline cleaners, abrasive cleaning compounds, or solvents. These substances may damage lens coatings and electronic circuitry.

WARNING: DO NOT use an excess of cleaning solution.

WARNING: DO NOT reuse swabs or wipes.

WARNING: DO NOT attempt to clean the sensor or optical cavity for any reason.

WARNING: DO NOT attempt to modify, dismantle, or open the camera, lens, or other accessory as doing so may expose you to electric shock and serious injury. There are no user-serviceable parts inside. Alteration or repairs made to the camera, lens, or other accessory, except by a Panavision authorized service facility, voids all warranties.

WARNING: DO NOT use compressed air and gas dusters on the sensor or on any optics.

CAMERA BODY AND ACCESSORY EXTERIOR SURFACES

- ▶ Use a filtered, non-residue gas duster to clean non-critical areas, such as around the fans and other recesses on the exterior of the camera.
- ▶ Clean with a dry lint-free cloth. When cleaning your camera and accessories, remember that the devices are not waterproof and moisture can damage electronic circuitry.

BRAIN AND ACCESSORY STORAGE

WARNING: DO NOT store the camera or accessories in any place with extreme temperatures, direct sunlight, high humidity, severe vibration, or strong magnetic fields.

WATER DAMAGE

WARNING: DO NOT attempt to power any device that may have water damage.

WARNING: DO NOT place the device in a container of rice, silica gel, or desiccant packets in an attempt to dry the device.

TROUBLESHOOT YOUR CAMERA

GENERAL TROUBLESHOOTING

FIRMWARE DOES NOT UPGRADE

SYMPTOM

- ▶ During an attempt to upgrade firmware, the PWR and REC LEDs flash red.
- ▶ After an attempt to upgrade firmware, the firmware version does not change.

POTENTIAL RESOLUTIONS

- ▶ After downloading the firmware upgrade file, ensure that you unzip the file before saving it to the SSD.
- ▶ Ensure that the "force_upgrade" folder is saved to the top level of the SSD, and not to a subfolder.

GENERAL: MODULE OR LENS MOUNT NOT FUNCTIONING

SYMPTOM

A module or lens mount is not functioning correctly, or is not communicating with the camera.

POTENTIAL RESOLUTIONS

- ▶ Upgrade your camera firmware. For more information, go to ["Upgrade Camera Firmware" on page 125](#).
- ▶ Reset your camera's default settings. For more information, go to ["Reset Defaults" on page 101](#).

SCREEN FREEZES OR DOES NOT DISPLAY

SYMPTOM

The screen freezes or does not display.

POTENTIAL RESOLUTION

Perform a Hard Restore. For more information, go to ["Perform a Hard Restore" on the next page](#).

LCD FLICKER

SYMPTOM

The LCD or monitor is flickering.

POTENTIAL RESOLUTIONS

- ▶ Set the LCD frequency to 60 Hz. For more information, go to ["Frequency" on page 59](#).
- ▶ Use a different cable.
- ▶ Ensure cables are properly attached.

PANAVISION MILLENNIUM DXL2

LCD BLANK AT STARTUP

SYMPTOM

When you turn on the camera, the LCD does not show any image.

POTENTIAL RESOLUTIONS

Turn off the camera. Wait at least three (3) seconds, and then turn the camera back on.

CAMERA DOES NOT TURN ON

SYMPTOM

The camera does not turn on (does not boot up), even when powered.

POTENTIAL RESOLUTIONS

- ▶ Remove all accessories and power the camera using the power adaptor.
- ▶ Perform a Hard Restore. For more information, go to ["Perform a Hard Restore" below](#).
- ▶ If the camera does not turn on when a battery is attached, but does turn on when DC power is attached, toggle the **Auto Boot on Power** switch to **Off** (identified by a black star).

PERFORM A HARD RESTORE

A common way to resolve camera firmware issues is to perform a Hard Restore. A Hard Restore functions like a System Restore in that it changes all settings to the factory default values.

To perform a Hard Restore, follow the instructions below:

1. With the camera turned off, hold the **PWR/REC** key on the camera for 20 seconds or until the fans turn at a high speed.
2. Release the **PWR/REC** key.

The screen displays correctly.

NOTE: User key settings reset as well as any other changes from the default settings.

IMAGE APPEARS GRAINY

SYMPTOM

Image or footage appears grainy.

POTENTIAL RESOLUTIONS

- ▶ Calibrate the sensor before recording additional clips. For more information, go to ["Sensor Calibration" on page 94](#).
- ▶ Check the histogram to ensure proper exposure. Noise occurs if an image is overexposed or underexposed.
- ▶ Use the lowest REDCODE[®] compression possible for the settings you have selected.
- ▶ Use a higher resolution.
- ▶ Use Adaptive fan mode to regulate the camera temperature. Noise occurs when the temperature from the applied calibration map is not in sync.

PANAVISION MILLENNIUM DXL2

BLACK AND WHITE IMAGE

SYMPTOM

The display shows that an image is in black and white, and the menus are still in color.

POTENTIAL RESOLUTIONS

- ▶ Check the Color Saturation setting. If the Saturation setting is set to a low value, change the Saturation to a higher value.
- ▶ Reset your camera's default settings. For more information, go to ["Reset Defaults" on page 101](#).

INCORRECT COLOR TEMPERATURE

SYMPTOM

The camera color temperature is off and the image looks warmer or cooler than normal.

POTENTIAL RESOLUTIONS

- ▶ Perform an auto white-balance. For more information, go to ["" on page 37](#).
- ▶ Calibrate the sensor. For more information, go to ["Sensor Calibration" on page 94](#).

TIMECODE OR GENLOCK DOES NOT FUNCTION

SYMPTOM

The SYNC, GEN, and/or TC light is red, yellow, or greyed out.

POTENTIAL RESOLUTIONS

- ▶ Ensure that your timecode or genlock device is compatible. For more information, go to ["Compatible Timecode Devices" on page 123](#) and ["Compatible Genlock Devices" on page 124](#).
- ▶ Use a different cable.
- ▶ Ensure that your timecode or genlock device settings match your project settings.
- ▶ Ensure that your timecode or genlock device is set to the correct source. For more information, go to ["Timecode" on page 114](#) and ["Genlock" on page 116](#).
- ▶ Ensure that your Sensor Sync Mode is set to **Genlock**. For more information, go to ["Sensor Sync" on page 117](#).
- ▶ Set the ACN (Ambient Clockit Network) to Off.

PANAVISION MILLENNIUM DXL2

POSSIBLE HOT PIXEL

SYMPTOM

Your camera displays a possible hot pixel.

EXPLANATION

There may not be an issue with the pixel itself. The sensor can display a hot pixel when the sensor calibration is outdated. Current camera settings and temperature can affect pixel calibration.

POTENTIAL RESOLUTIONS

- ▶ Calibrate the sensor. For more information, go to ["Sensor Calibration" on page 94](#).
- ▶ Upgrade your camera firmware. For more information, go to ["Upgrade Camera Firmware" on page 125](#).
- ▶ Reset your camera's default settings. For more information, go to ["Reset Defaults" on page 101](#).
- ▶ Check your footage on a computer to confirm that the hot pixel is from the camera sensor, not your display monitor.
- ▶ If you determine that the camera sensor has a hot pixel, use REDCINE-X PRO to remove the hot pixel until the issue gets resolved. For more information, see the REDCINE-X PRO Operation Guide, available at www.red.com/downloads.

ERROR MESSAGES

"UPGRADE ATTACHED PERIPHERALS" MESSAGE

SYMPTOM

During an attempt to upgrade firmware, the display shows the message "Upgrade Attached Peripherals". After turning the camera off and then on, the same message displays, and then prompts you to turn off the camera.

POTENTIAL RESOLUTION

- ▶ Ensure that you are upgrading your camera to the newest firmware version.
- ▶ One (1) of your modules or lens mounts (collectively known as "peripherals") may be experiencing issues. Remove all peripherals (except for the media bay), and upgrade firmware. Then attach another peripheral, and upgrade firmware again. Repeat this process, upgrading one (1) peripheral at a time. This will identify which peripheral is experiencing issues.

PRESET COULD NOT BE APPLIED

SYMPTOM

The display shows the following message: "Preset Could Not Be Applied".

POTENTIAL RESOLUTION

Turn off the camera, power it back up, and attempt to apply the preset that failed.

APPENDIX A: TECHNICAL SPECIFICATIONS

PANAVISION MILLENNIUM DXL2

PANAVISION MILLENNIUM DXL2	
SPECIFICATION	DESCRIPTION
Sensor Type	16-bit, 35.5 Megapixel CMOS
Resolution	8192 x 4320
Sensor Size	Large Format: 40.96mm x 21.60mm (Diagonal: 46.31mm)
Dynamic Range	16 stops
Max Frame Rates	60 fps at 8K Full Frame (8192 x 4320) 75 fps at 8K 2.4:1 (8192 x 3456)
Recording Codec	8K RAW with simultaneous 4K proxy (ProRes or DNx)
Recording Media	SSD (up to 1 hour on a single magazine)
File Type	.r3d (supported in RED SDK)
Color Profile	Light Iron Color 2 (compatible with all popular gamuts and transfer curves, including RAW, ACES, selectable)
Weight	10 lbs.



APPENDIX B: MECHANICAL DRAWINGS

NOTE: Dimensions are shown in mm.

FRONT VIEW

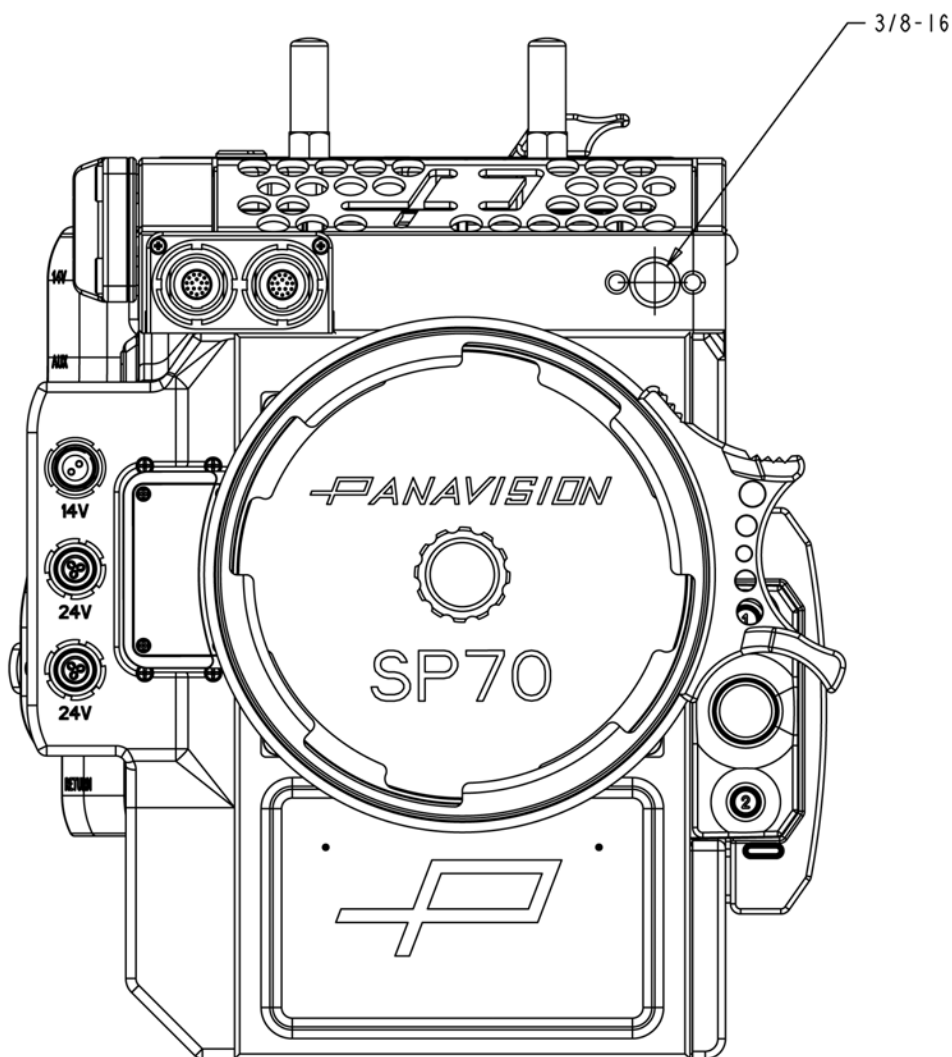

Figure: Panavision Millennium DXL2 Front View

PANAVISION MILLENNIUM DXL2

SIDE VIEW (RIGHT)

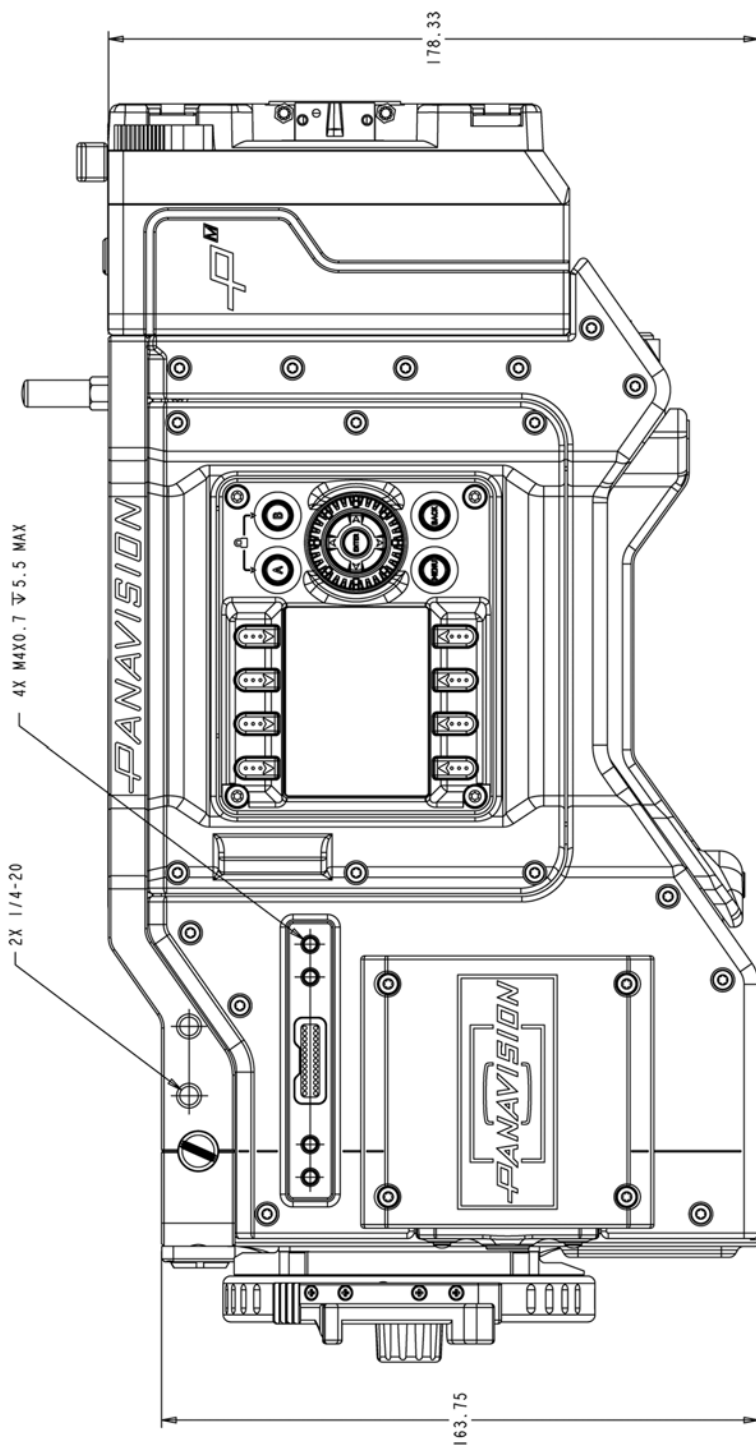

Figure: Panavision Millennium DXL2 Side View (Right)

PANAVISION MILLENNIUM DXL2

SIDE VIEW (LEFT)

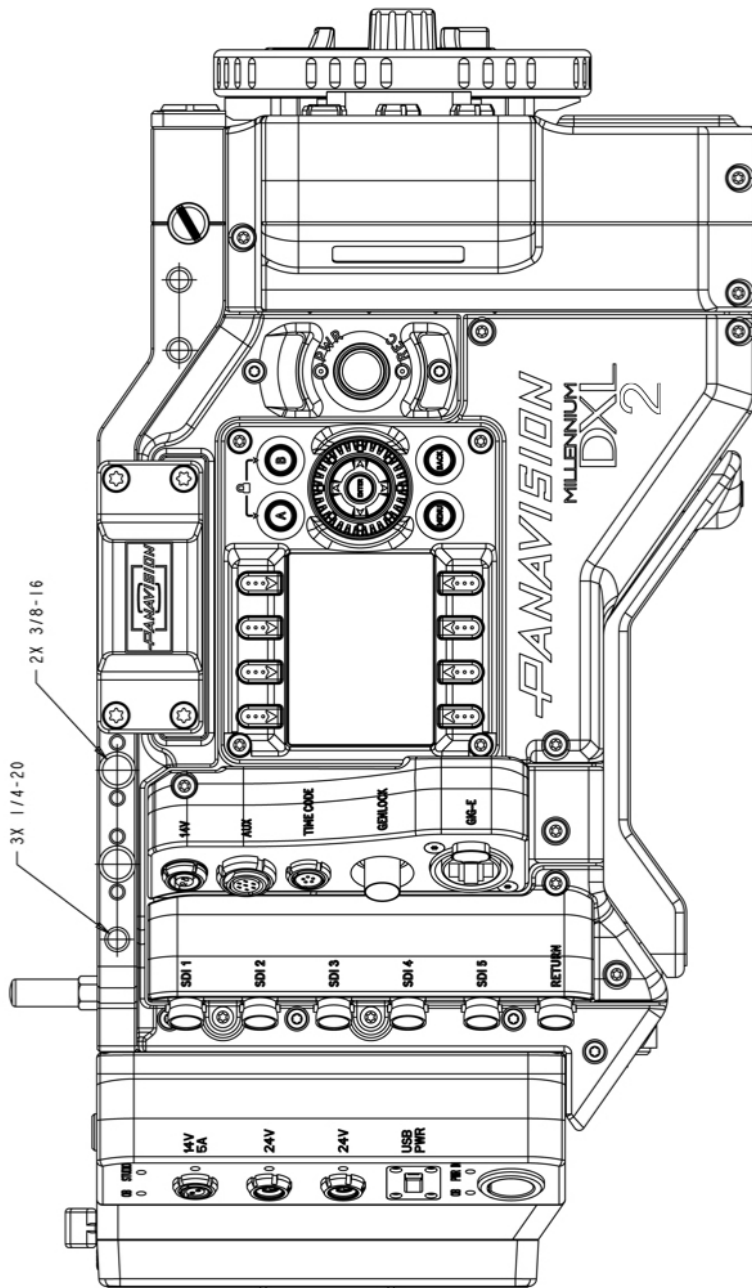

Figure: Panavision Millennium DXL2 Side View (Left)

PANAVISION MILLENNIUM DXL2

TOP VIEW

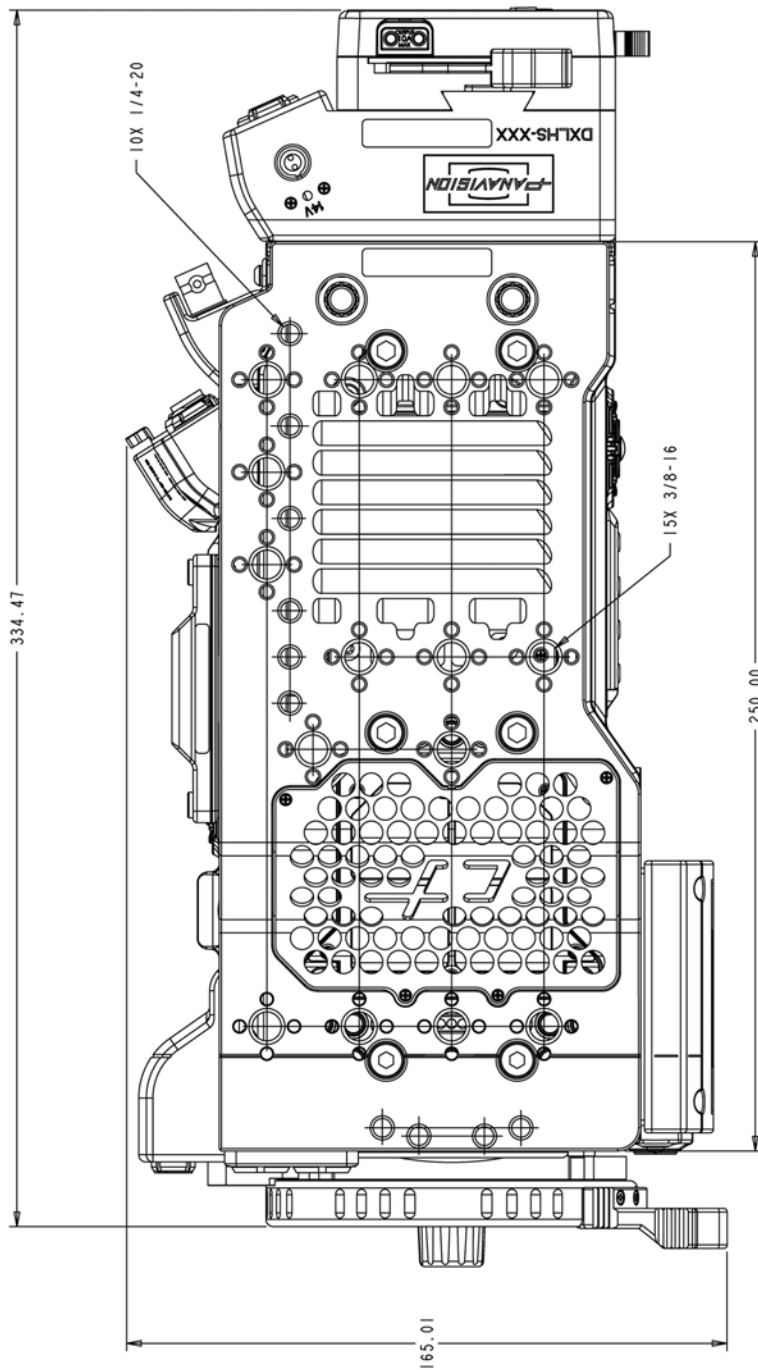

Figure: Panavision Millennium DXL2 Top View

APPENDIX C: INPUT/OUTPUT CONNECTORS

CONNECTORS

This appendix provides pinout information for the input/output connectors on the camera.

NOTE: When connecting a cable to a connector, align the key and red marker on the cable connector with the corresponding key and marker on the device connection.

NOTE: Connector diagram images are for reference only. Diagrams are not to scale.

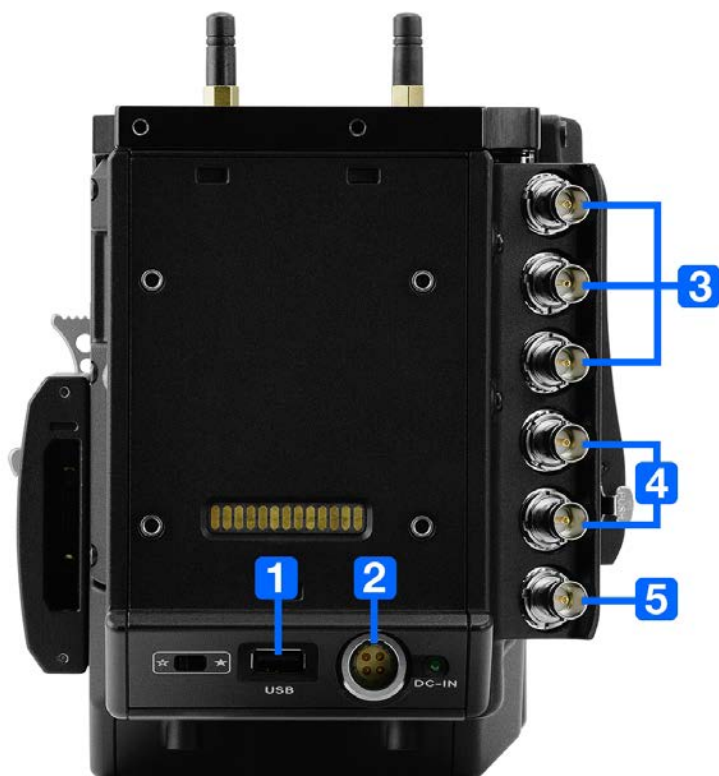

Figure: Panavision Millennium DXL2 Connectors



Figure: Panavision Millennium DXL2 Connectors

PANAVISION MILLENNIUM DXL2

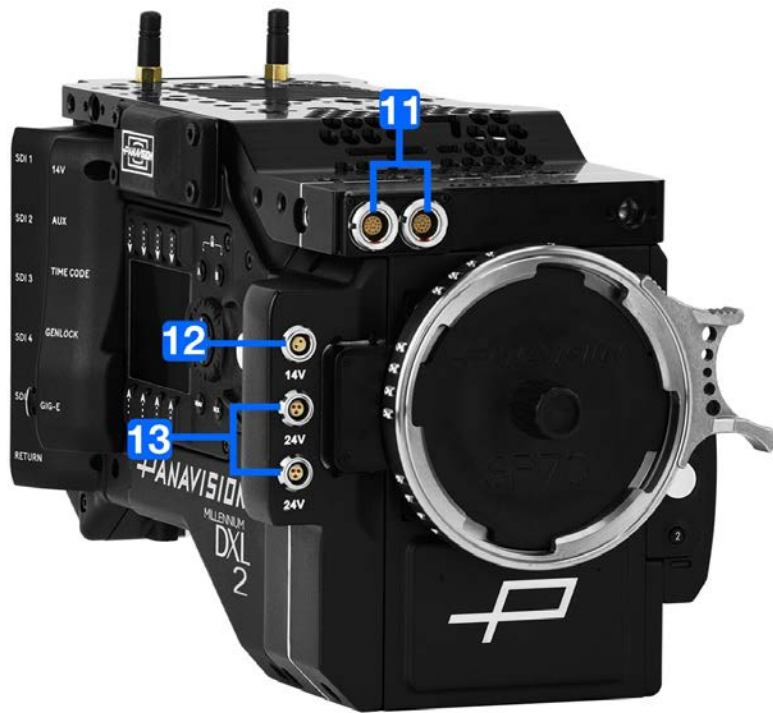

Figure: Panavision Millennium DXL2 Connectors

PANAVISION MILLENNIUM DXL2

#	CONNECTOR NAME	MODULE	DESCRIPTION	CONNECTOR TYPE	DETAILS
1	USB	Camera	USB power out	USB 2.0, Type A (power only)	"USB Power" on the next page
2	DC-IN	Camera	Power in	4-pin 2B LEMO	"DC-IN" on the next page
3	SDI 1 SDI 2 SDI 3	SDI Module	3G HD-SDI	BNC	"3G HD-SDI" on page 143
4	SDI 4 SDI 5	SDI Module	6G/3G HD-SDI	BNC	"6G/3G HD-SDI" on page 142
5	RETURN	SDI Module	3G HD-SDI	BNC	"RETURN" on page 143
6	14V	Communication Module	Aux power out	2-pin LEMO	"14V Aux Power Out" on page 147
7	AUX	Communication Module	Aux power out	7-pin LEMO	"AUX Power Out" on page 145
8	TIMECODE	Communication Module	Timecode in and out	5-pin LEMO	"TIMECODE" on page 146
9	GENLOCK	Communication Module	Genlock	BNC	"GENLOCK" on page 146
10	GIG-E	Communication Module	Ethernet	8-pin RJ45 Ethernet	"GIG-E" on page 147
11	LCD/EVF (2x)	Top Plate	LCD/EVF	LEMO	"LCD/EVF Ports" on page 147
12	14V	DXLM Module		2-pin LEMO	"14V Aux Power Out" on page 147
13	24V (2x)	DXLM Module		3-pin Fischer	"24V Aux Power Out" on page 148



PANAVISION MILLENNIUM DXL2

USB POWER

The USB power-out connector supplies 5V of power. The maximum sustained current draw is 1.5A.

NOTE: The USB connector only offers power out, and does NOT support USB communication.

DC-IN

The 4-pin 2B LEMO connector (LEMO EGJ.2B.304.CLA) accepts DC input power from 11.5V DC to 17V DC.

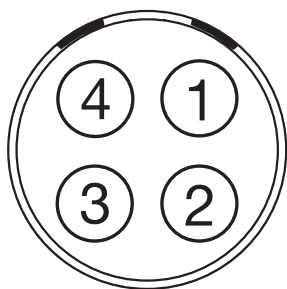

Figure: Front Face of the Connector (Looking at the Camera)

LEMO EGJ.2B.304.CLA CONNECTOR			
PIN	SIGNAL	DESCRIPTION	DIRECTION
1	14V	VBATT (11.5 TO 18V DC) @ 9A	In
2	Ground	Common ground	N/A
3	28V	VBATT (18 to 30V DC) @ 3A Exclusively powers attached accessories and lens control devices. Power from this pin does NOT power the camera.	In
4	Ground	Common ground	N/A

NOTE: Mating connectors are FGJ.2B.304.CLLD62Z and FGJ.2B.304.CLLD52.

PANAVISION MILLENNIUM DXL2

6G/3G HD-SDI

A standard 75 ohm BNC connector provides the following output:

- ▶ Broadcast specification 3G-SDI (HD-SDI) video output (default mode is Clean)
- ▶ Two (2) channels of embedded audio
- ▶ Time of Day and Edge timecode
- ▶ Record Tally flag
- ▶ Clip name information (as SMPTE RP-188 VITC2 HANC metadata)

The 6G/3G-SDI (HD-SDI) output provides the formats described in the table below:

6G/3G-SDI (HD-SDI) OUTPUT FORMATS ¹		
VIDEO FEED ²	FREQUENCY (HZ) ³	SMPTE STANDARD
720p	23.98, 24.00, 25.00, 29.97, 30.00, 50.00, 59.94	SMPTE ST 292-1 (1.485 Gbps)
1080p 10-bit 4:2:2	23.98, 24.00, 25.00, 29.97, 30.00	SMPTE ST 292 (1.485 Gbps)
1080p 10-bit 4:2:2	50.00, 59.94, 60.00	3G-SDI SMPTE ST 424 (2.970 Gbps) SMPTE ST 425 (2.970 Gbps)
UHD 10-bit 4:2:2	23.98, 24.00, 29.97, 30.00	6G-SDI SMPTE 2081(5.940 Gbps)

1. Ensure you select a frequency supported by your monitor.
2. The output is progressive scan (p); it does not support progressive segmented frame (PsF) or interlaced (i) scan formats.
3. The frequency options depend on project time base. If you have a non-drop frame project time base (such as 24.00), you can select only non-drop frame frequencies. If you have a drop frame project time base (such as 23.98), you can select only drop frame frequencies.

75 OHM BNC CONNECTOR			
PIN	SIGNAL	DESCRIPTION	DIRECTION
Center	6G/3G-SDI	SMPTE ST 424	Out
Shield/Screen	GROUND	Camera ground	N/A

PANAVISION MILLENNIUM DXL2

3G HD-SDI

A standard 75 ohm BNC connector provides the following output:

- ▶ Broadcast specification 3G-SDI (HD-SDI) video output (default mode is Clean)
- ▶ Two (2) channels of embedded audio
- ▶ Time of Day and Edge timecode
- ▶ Record Tally flag
- ▶ Clip name information (as SMPTE RP-188 VITC2 HANC metadata)

The 3G-SDI (HD-SDI) output provides the formats described in the table below:

3G-SDI (HD-SDI) OUTPUT FORMATS ¹		
VIDEO FEED ²	FREQUENCY (HZ) ³	SMPTE STANDARD
720p	23.98, 24.00, 25.00, 29.97, 30.00, 50.00, 59.94	SMPTE ST 292-1 (1.485 Gbps)
1080p 10-bit 4:2:2	23.98, 24.00, 25.00, 29.97, 30.00	SMPTE ST 292 (1.485 Gbps)
1080p 10-bit 4:2:2	50.00, 59.94, 60.00	3G-SDI SMPTE ST 424 (2.970 Gbps) SMPTE ST 425 (2.970 Gbps)

1. Ensure that you select a frequency supported by your monitor.
2. The output is progressive scan (p); it does not support progressive segmented frame (PsF) or interlaced (i) scan formats.
3. The frequency options depend on project time base. If you have a non-drop frame project time base (such as 24.00), you can select only non-drop frame frequencies. If you have a drop frame project time base (such as 23.98), you can select only drop frame frequencies.

75 OHM BNC CONNECTOR			
PIN	SIGNAL	DESCRIPTION	DIRECTION
Center	3G-SDI	SMPTE ST 424	Out
Shield/Screen	GROUND	Camera ground	N/A

RETURN

A standard 75 ohm BNC connector provides the ability to feed an HD-SDI signal into the camera. For more information, go to ["Allow Return Feed" on page 60](#).

75 OHM BNC CONNECTOR			
PIN	SIGNAL	DESCRIPTION	DIRECTION
Center	3G-SDI	SMPTE ST 424	In
Shield/Screen	GROUND	Camera ground	N/A

PANAVISION MILLENNIUM DXL2

14V AUX POWER OUT

The DXLM Module offers one (1) 14V AUX power port.

The 2-pin 0B LEMO connector (LEMO EEG.0B.302.CLL) supplies unregulated (+) 11.5 to 17V DC battery pass-through power. The maximum sustained current draw is 3.0A.

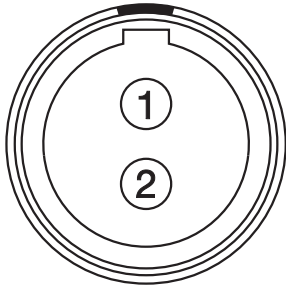

Figure: Front Face of Connector (Looking at the Camera)

LEMO EEG.0B.302.CLL CONNECTOR			
PIN	SIGNAL	DESCRIPTION	DIRECTION
1	GROUND	Common ground	N/A
2	+11.5 to +17V DC	+11.5 to 17V DC unregulated battery pass-through power	Out

NOTE: Mating connector is FGG.0B.302.CLAD.

PANAVISION MILLENNIUM DXL2

AUX POWER OUT

The 7-pin 1B LEMO connector supports RS232 and a General Purpose Input (GPI) trigger. The connector also offers auxiliary power out, with a maximum sustained current draw of 2.0A.

To operate the GPI contact closure style trigger, short Pin 7 (GPI) to Pin 6 (ground).

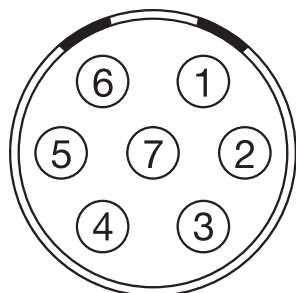

Figure: Front Face of the Connector (Looking at the Camera)

7-PIN 1B LEMO AUX CONNECTOR			
PIN	SIGNAL	DESCRIPTION	DIRECTION
1	GND	Camera ground	N/A
2	RS232 RX	RS232 RX (Receive)	In
3	RS232 TX	RS232 TX (Transmit)	Out
4	+VBATT (11.5 to 17V DC) @ 2.0A	+11.5 to +17 VDC unregulated battery pass-through power	Out
5	NC	No connection (NC)	N/A
6	GND	Camera ground	N/A
7	GPI	General Purpose In (GPI) trigger (active-low switch closure)	In

NOTE: Mating connector is FGB.1B.307.CLAD52 (straight).

CONTACT CLOSURE STYLE TRIGGER BUTTON CIRCUIT

The diagram below shows the contact closure style trigger button circuit on the connector.

Momentary Action

Push Button

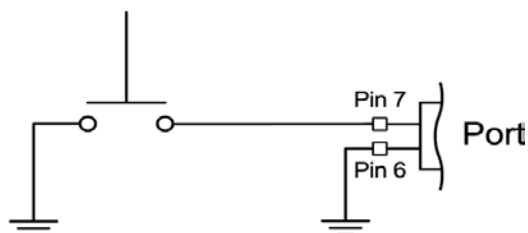

Figure: Contact Closure Style Trigger Button Circuit Diagram

PANAVISION MILLENNIUM DXL2

TIMECODE

The LEMO EAG.0B.305.CLN connector supports SMPTE timecode input and output. Pins 2 and 3 can be used together to receive a balance SMPTE 12M serial timecode input. Pin 2 can be used by itself (leave pin 3 open) to receive a single-ended SMPTE 12M serial timecode input. Pin 5 is a timecode output.

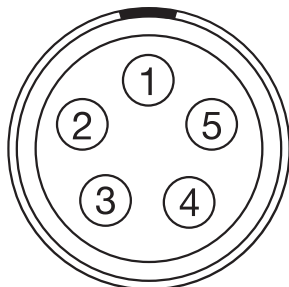

Figure: Front Face of Timecode (LEMO EAG.0B.305.CLN) Connector (Looking at the Camera)

LEMO EAG.0B.305.CLN CONNECTOR			
PIN	SIGNAL	DESCRIPTION	DIRECTION
1	GROUND	Camera Ground	N/A
2	TIMECODE IN(S)	Timecode input - SMPTE single ended	In
3	N/A	No connection (NC)	N/A
4	+5V OUT	+5V out, 200 mA max	Out
5	TIMECODE OUT	SMPTE 12M Timecode output	Out

NOTE: Mating connector is FHG.0B.305.CLAD.

GENLOCK

The 75 ohm BNC connector accepts incoming sync and genlock signals.

75 OHM BNC CONNECTOR			
PIN	SIGNAL	DESCRIPTION	DIRECTION
Center	SYNC	SMPTE ST 274 RS 170A Tri-Level Sync	In
Shield/Screen	GROUND	Camera ground	N/A

PANAVISION MILLENNIUM DXL2

GIG-E

The GIG-E 8-pin RJ45 Ethernet connector provides a 1000BASE-T (IEEE 802.3ab) gigabit Ethernet connection for remote camera setup, master/slave camera communication, and external metadata ingest. Since the GIG-E connector does not support slower speeds (10BASE-T and 100BASE-T), ensure that any device you connect to supports 1000BASE-T.

GIG-E CONNECTOR			
PIN	SIGNAL	DESCRIPTION	DIRECTION
1	BI_DA+	Data pair A+	N/A
2	BI_DA-	Data pair A-	N/A
3	BI_DB+	Data pair B+	N/A
4	BI_DC +	Data pair C+	N/A
5	BI_DC -	Data pair C-	N/A
6	BI_DB-	Data pair B-	N/A
7	BI_DD+	Data pair D+	N/A
8	BI_DD -	Data pair D-	N/A

LCD/EVF PORTS

Custom digital video and power interconnection between the camera and RED LCDs and EVFs. The pinout is not published.

14V AUX POWER OUT

The DXLM Module offers one (1) 14V AUX power port.

The 2-pin 0B LEMO connector (LEMO EEG.0B.302.CLL) supplies unregulated (+) 11.5 to 17V DC battery pass-through power. The maximum sustained current draw is 3.0A.

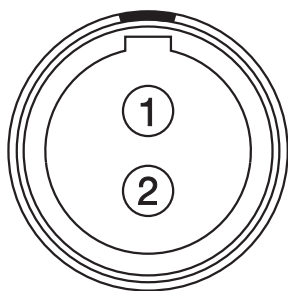

Figure: Front Face of Connector (Looking at the Camera)

LEMO EEG.0B.302.CLL CONNECTOR			
PIN	SIGNAL	DESCRIPTION	DIRECTION
1	GROUND	Common ground	N/A
2	+11.5 to +17V DC	+11.5 to 17V DC unregulated battery pass-through power	Out

NOTE: Mating connector is FGG.0B.302.CLAD.

PANAVISION MILLENNIUM DXL2

24V AUX POWER OUT

The DXLM Module offers two (2) Fischer 3-pin 102 connectors that up convert from 12V to 24V.

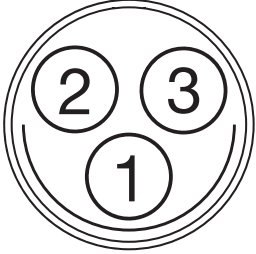

Figure: 24V Connector (Looking at the Camera)

FISCHER 3-PIN CONNECTOR			
PIN	SIGNAL	DESCRIPTION	DIRECTION
1	GROUND	Common ground	N/A
2	24V	24V	Out
3	Trigger	Active Low to start/stop record	In

LENS INFORMATION

LENS MOUNT

The Panavision Millennium DXL2 features a built-in SP70 lens mount, which is compatible with Primo 70 Series lenses. The lens mount is also compatible with select adaptors that support other lens mounts.

LENS WEIGHT AND LENS SUPPORT

Use a lens support system when mounting heavy or long lenses to your camera.

When mounting a heavy or long lens, ensure that the full weight of the lens is never directly on the camera or lens mount. Mount the lens to the support system first, and then carefully mount the lens to the camera.

DEFAULT KEY FUNCTIONS

DEFAULT KEYS

ITEM	KEY	DEFAULT FUNCTION
Camera Right Side (Assistant Side)	PWR/REC Full Press	Record: Toggle
	PWR/REC Press Two (2) Seconds	Turn off camera
	PWR/REC Press Five (5) Seconds	Force turn off camera
	Assistant A Press ¹	Assistant A + Assistant B: Toggle lock/unlock all keys on Assistant Side
	Assistant B Press ¹	Assistant A + Assistant B: Toggle lock/unlock all keys on Assistant Side
	Nav North Press	Move cursor up
	Nav South Press	Move cursor down
	Nav East Press	Move cursor right Select menu
	Nav West Press	Move cursor left Return to the last menu
	Nav Enter Press	Navigation: Select
	Navigation Wheel CW	Move cursor down
	Navigation Wheel CCW	Move cursor up
	Menu Press	Access/Exit menus
	Back Press	Return to the last menu

1. Programmable key action.



PANAVISION MILLENNIUM DXL2

ITEM	KEY	DEFAULT FUNCTION
Camera Left Side (Operator Side)	Record Full Press	Record: Toggle
	Record Half Press	AF: Start
	User 1 Press ¹	Not Assigned
	User 2 Press ¹	Not Assigned
	User 1+2 Press	Eject Media
	Operator A Press ¹	Operator A + Operator B: Toggle lock/unlock all keys on Operator Side
	Operator B Press ¹	Operator A + Operator B: Toggle lock/unlock all keys on Operator Side
	Nav North Press	Move cursor up
	Nav South Press	Move cursor down
	Nav East Press	Move cursor left Select menu
	Nav West Press	Move cursor right Return to the last menu
	Nav Enter Press	Navigation: Select
	Navigation Wheel CW	Move cursor down
	Navigation Wheel CCW	Move cursor up
	Menu Press	Access/Exit menus
Back Press	Return to the last menu	

1. Programmable key action.

MENU MAP

See the Menu Map on the following page.

PANAVISION MILLENNIUM DXL2

