

# The **PRESSURE COOKER**

by *MegaChef*

## **8-QUART DIGITAL PRESSURE COOKER**

MCPR120A



### **OWNER'S MANUAL**

*SAVE THESE INSTRUCTIONS. FOR HOUSEHOLD USE ONLY.*

# CAUTION HOT STEAM

RISK OF SCALDING: USE TONGS OR LONG UTENSIL  
TO TURN THE PRESSURE LIMITING VALVE.

KEEP HANDS AND FACE AWAY FROM PRESSURE  
LIMITING VALVE WHILE IN THE EXHAUST POSITION.



FAILURE TO COMPLY MAY CAUSE SERIOUS INJURY.

DO NOT RELEASE PRESSURE UNDER HANGING  
CABINETS WHICH CAN BE DAMAGED BY STEAM.

Always use an oven mitt to reduce risk of injury.

To avoid liquid splatter, do not manually release the pressure  
from the valve for foods with a high volume of liquid (stews,  
soups, porridges, etc.).



**DO NOT ALLOW  
CHILDREN TO  
OPERATE UNDER ANY  
CIRCUMSTANCES**



**CLOSE SUPERVISION IS  
MANDATORY WHEN THE PRESSURE  
COOKER IS USED NEAR CHILDREN.**

Thank you for purchasing our product.

Make sure you have read the manual before using this product.

Please use the appliance in accordance with the instructions.

Please save these instructions. This item is intended for household use only.

**IMPORTANT:**

Do not use this appliance until you have read this entire manual thoroughly!



# CONTENTS

• IMPORTANT SAFEGUARDS	6
• SAFETY WARNING/ADDITIONAL SAFETY TIPS	8
• ABOUT YOUR PRESSURE COOKER	9
• RUBBER SEALING RING ASSEMBLY	9
• PARTS IDENTIFICATION	10
• BEFORE FIRST USE	11
• PREPARING YOUR PRESSURE COOKER	13
• OPERATING INSTRUCTIONS	14
• CLEANING INSTRUCTIONS	24
• HELPFUL TIPS	25

# IMPORTANT SAFEGUARDS



When using pressure cooker, basic safety precautions should always be followed:

1. Read all instructions before operation.
2. DO NOT touch hot surfaces. Use handles and a potholder.
3. **This appliance should not be used near children, or individuals with certain disabilities.**
4. **DO NOT ALLOW CHILDREN TO OPERATE UNDER ANY CIRCUMSTANCE.**
5. **NEVER ATTEMPT TO OPEN LID WHILE THE UNIT IS OPERATING. Do not open the pressure cooker until the unit has cooled down and all internal pressure has been released.** If the lid is difficult to rotate, this indicates that the cooker is still pressurized. Do not force it to open. Any pressure in the cooker can be hazardous.
6. DO NOT place the pressure cooker on or near a hot gas stove-top, electric burner or in a heated oven.
7. Extreme caution must be used when moving a pressure cooker containing hot liquids.
8. DO NOT use pressure cooker for other than intended use.
9. This appliance cooks under pressure. **IMPROPER USE MAY RESULT IN SCALDING INJURY.**
10. Ensure that the unit is properly closed before operating. (See "BEFORE FIRST USE" section, page 11)
11. To protect against electrical shock, do not immerse cord, plugs, or outer vessel in water or other liquids.
12. Do not fill the unit over 4/5 full. When cooking foods that expand during cooking (such as rice, legumes, beans or dried vegetables) do not exceed the 3/5 full mark. Overfilling may result in clogging of the pressure limiting valve and excess pressure.
13. Please note that certain foods (such as applesauce, cranberries, pearl barley, oatmeal or other cereals, split peas, noodles, macaroni, spaghetti or rhubarb) can foam, froth, and sputter, clogging the pressure release valve and the filter. These foods should not be cooked in a pressure cooker.
14. Always check the pressure release valve and the filter for clogging **before use.**
15. DO NOT use this pressure cooker for pressure frying of oil.

16. Clean the filter regularly to keep the cooker clean.
17. DO NOT tamper with the sealing ring in the lid using any tools or external forces. If the sealing ring is damaged, please stop using immediately.
18. Never use additional weight on the pressure limiting valve or replace it with any other object.
19. The surface of contact between the inner pot and the heating plate should always be clean. DO NOT use the inner pot with other heating sources. DO NOT replace the inner pot with a container other than what is recommended by the manufacturer.
20. The inner pot is made out of a Stainless Steel .
21. Unplug from outlet when not in use and before cleaning. Allow to cool before putting on, or removing parts.
22. Do not operate this appliance with a damaged cord or plug, or after it malfunctions or has been damaged in any manner. Return the appliance to the retailer or contact us directly at 1-800-788-7618 .
23. Always attach the plug to the appliance first, then plug the cord into the wall outlet. To disconnect, press the “KEEP WARM/CANCEL” button, then unplug from wall outlet.
24. Do not use outdoors.
25. Some counter-top and table surfaces, such as Corian®, wood and/or laminates, are not designed to withstand prolonged heat generated by certain appliances. It is recommended by counter-top manufacturers that a hot pad or trivet be placed under your appliance to prevent possible damage to the surface.
26. Do not use under hanging or wall cabinets; steam from pressure release may cause damage. DO NOT disassemble the product, or replace parts with parts not intended for this unit.
27. Do NOT operate your appliance in a garage. To avoid a risk of fire, always unplug the unit from the electrical outlet when storing in a garage.
28. Any servicing should be performed by an authorized service representative.
29. The use of accessories or attachments may cause injuries and is strictly prohibited by the appliance manufacturer.

# SAFETY WARNINGS



- There is a potential risk of fire, electric shock or injury to persons if the product is not used as instructed. Protection against electric shock is assured only if the main power cord is connected to a properly grounded 120V | 60Hz power outlet.
- This product is to be used indoors, in a dry environment only and is not intended for commercial use.
- All parts and accessories for this appliance must be used properly according to the instructions and must be the original provided from manufacturer. The use of any other parts or accessories that are not intended for use with this appliance is strictly prohibited.
- The use of an extension cord, power adapter or other electric devices is not recommended.

## LED ERROR INDICATOR

Indicator Code	Problem / Cause
E1	Open circuit of the sensor
E2	Short circuit of the sensor
E3	Overheating
E4	Signal Switch Malfunction



# ABOUT YOUR PRESSURE COOKER

This digitally controlled and automatic pressure cooker uses advanced technology so you and your family can enjoy the benefits of better, faster and healthier cooking.

Your Megachef Pressure Cooker seals in steam to cook hotter and quicker, while maintaining important nutrients for healthier meals. Cooking fast and with less water saves vital natural resources and energy!

The unit features easy touch-button settings, a countdown timer, and a cooking pot big enough for family gatherings! This pressure cooker is simple to use, makes meals quick and easy, and saves you money!

## PRESSURE COOKER WITH MULTIPLE FUNCTIONS

Multiple functions for cooking, stewing, braising and simmering.

Cooking will be done automatically by selecting the different menu choices on the unit.

The pressure cooker also has its own memory; in case of interruptions, such as a power failure, the unit will automatically resume the cooking cycle where it was left off.

## RAPID COOKING; TIME & POWER SAVING

By using high pressure and high temperature, food will be cooked much faster. This will reduce the cooking time and consumption of power. For example: when cooking rice, this pressure cooker will save up to 20% of the electricity and up to 15% of the time when compared to a conventional rice cooker. When cooking stew, soups or braising meats, this cooker will save more than 40% of time and more than 45% of power as compared to a conventional slow cooker. Cooking can also be done at high altitudes.

## PRESERVES NUTRIENTS & PROMOTES HEALTHY EATING

Airtight cooking methods preserve nutrients and original flavor of food.

## SPECIFICATIONS

Working pressure	Psi	Maximum Pressure	Keep Warm Temperature
0-70KPa	12 Psi	90KPa	140°F - 175°F

**Voltage/ Frequency : 120V | 60Hz**

**Power : 1600W**

# PARTS IDENTIFICATION



## ACCESSORIES



Measuring Cup



Spoon

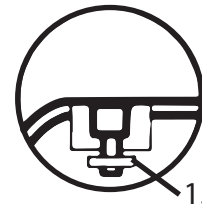

15

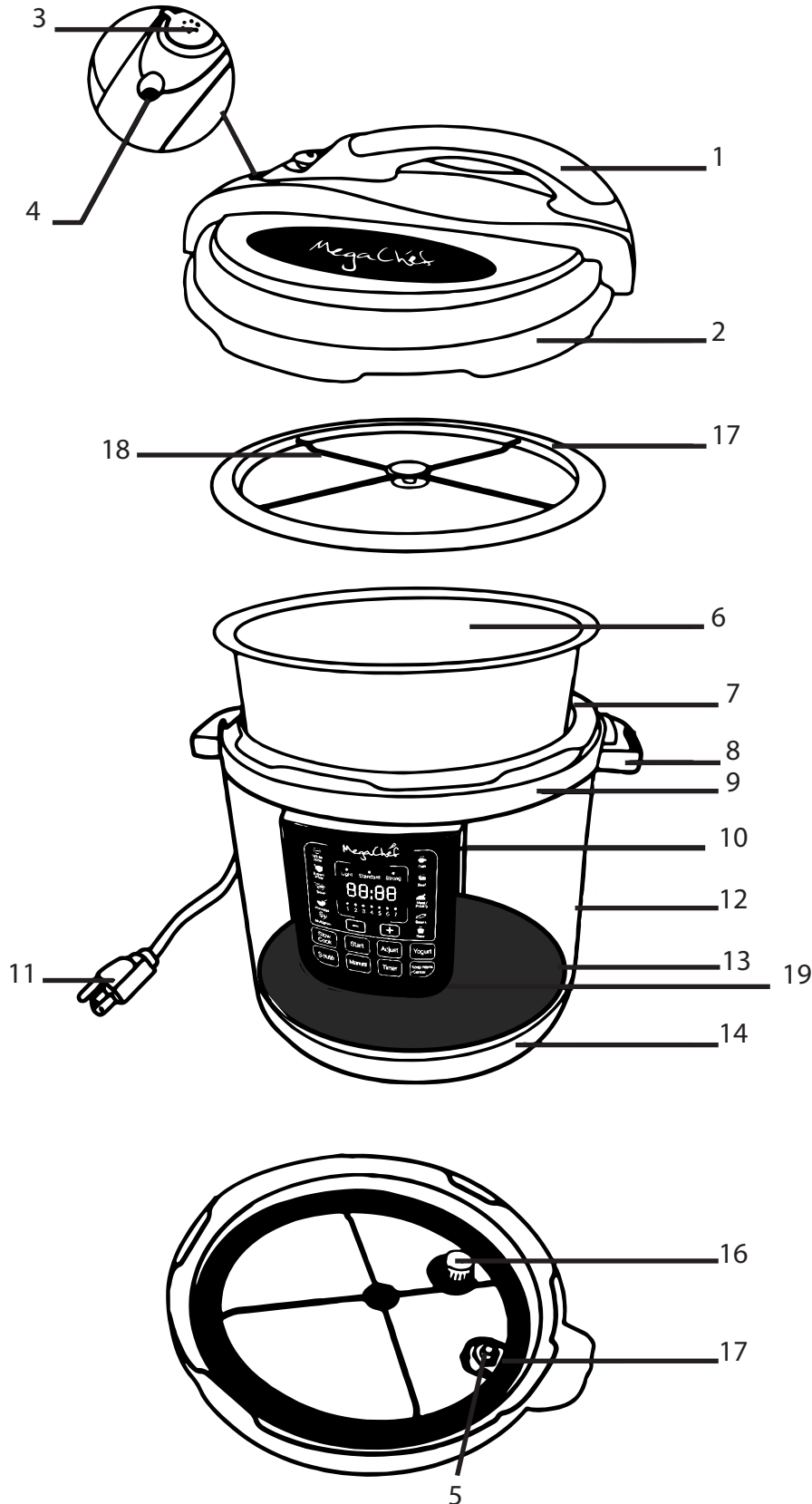

1. Lid Handle
2. Lid
3. Pressure Limiting Valve
4. Float Valve (external view)
5. Float Valve (internal view)
6. Stainless Steel Inner Pot
7. Outer Pot
8. Side Handles
9. Upper Ring
10. Control Panel
11. Power Cable
12. Main Outer Body
13. Heating Plate
14. Bottom Ring
15. Float Valve Seal Ring
16. Filter
17. Rubber Sealing Ring
18. X-Shaped Metal Ring
19. Sensor



## BEFORE FIRST USE

1. Remove packaging materials such as cardboard, plastics or Styrofoam and discard appropriately.
2. Clean all the parts by wiping with a soft damp cloth or sponge and dry thoroughly.
3. Thoroughly clean the cooking pot in the dishwasher or with warm soapy water. Rinse, towel or air-dry, and place in the pressure cooker.

### RUBBER SEALING RING ASSEMBLY

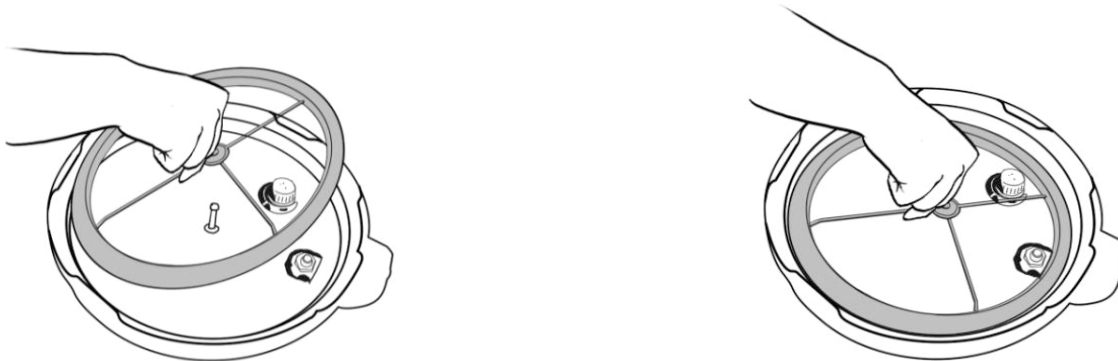

Always ensure the rubber sealing ring (17) is securely fitted onto the X-shaped metal ring (18). Make sure the crease in the rubber sealing ring meets with the outside of the X-ring all the way around. Then place the X-ring and rubber seal ring back into the lid (2), making sure the hole in the center of the X-ring's cross-section is lined up with the metal pin in the center of the lid. Press down firmly until the X-ring is secured onto the lid.

### PRESSURE LIMITING VALVE

Adjust the pressure limiting valve (3) to the airtight position by turning it so it points towards the back of the unit (fig 1). To release pressure, turn it 180° counter-clockwise so it points towards the front panel (fig 2). Use the arrows around the pressure valve as guidelines.



Fig. 1



Fig. 2

\* You will notice that the valve rises or sinks-in while being moved side to side. The valve is in airtight position every time it sinks-in and wobbles; if it is risen up, it is in release position.

## OPENING LID

Hold the handle (1) firmly, turn the lid (2) clockwise to the “Open” position and lift up.

\* The lid may be slightly tighter during the first uses; it will loosen up once it has been opened and closed several times.



## CLOSING LID

1. Align the “Open” arrow on the lid to the “Open “ circle on the upper ring of the unit (9).
2. Turn counter-clockwise until the “Close” positions on the lid and the upper ring align. You should hear a rattle indicating that the unit is closed.



- If any steam is escaping around the lid, the rubber seal ring may not have completed a tight seal when the lid locked. Cancel the cooking process, release pressure manually, remove the lid and reposition the rubber seal ring properly.
- Please note that steam escaping from the valve or around the lid is normal for the first 5 minutes or so of the cooking process. If it continues beyond 10 minutes, please cancel the process and follow the instructions to release all the pressure before removing the lid to check the valve or the rubber sealing ring.

# PREPARING YOUR PRESSURE COOKER

For the first use, to ensure correct assembly of the rubber sealing ring, it is recommended to fill the inner pot (6) with water to the 2/5 line and program to pressure cook for 30 minutes. (Refer to “Operating Instructions” section on page 14 for how to start the unit.)

Once completed, pour out the water. Rinse and towel dry the inner pot . The pressure cooker is now ready for use.

## **Make sure to wait 60 minutes for the pot to cool before usage**

Note: The total volume of food and liquid must not exceed 4/5 of the capacity of the stainless steel cooking pot.

For foods such as dried vegetables and beans, or rice and grains, the total volume must not exceed 3/5 the capacity. Overfilling may clog the pressure limiting valve, which can cause excess pressure. Always use at least ½ cup liquid when pressure cooking.

## **Warning: to avoid a serious burn injury when cooking foods other than rice, the combined volume of liquids and solids should never exceed the 4/5 mark.**

Ensure that the inner receptacle, where the heating plate (13) is located, is clean and dry before inserting the inner pot into the pressure cooker. If necessary, adjust the pot left and right to ensure optimal contact between the inner pot and the heating plate.

# OPERATING INSTRUCTIONS



## USING PRE-PROGRAMMED SETTINGS

The MCPR120A comes with 13 pre-programmed settings for convenient and easy cooking; each one of these settings has default time preset for quick cooking, and is programmed to detect the weight of the food being cooked, and the volume of liquid inside the pot during the cooking process. When using one of the pre-programmed setting, the unit will automatically build up the pressure, cook the food, and then switch to “KEEP WARM/CANCEL” to keep the food warm once cooking is complete.

1. Prepare desired food and place it into the inner cooking pot. *(The food should be more than 3 pounds, or more than 6 cups.)*
2. Secure the lid onto the unit and turn it counter clockwise to lock it in place (See page 12).
3. Move the pressure limiting valve side to side until it seals properly (See page 11).
4. Plug the power cord into a 120V outlet. The LED screen will display 0000



WHITE RICE, BROWN RICE, SOUP, PORRIDGE, MULTIGRAIN, FISH, BEEF, MEAT/POULTRY, BEANS, STEW, YOGURT, SLOW COOK and SAUTÉ are accessible directly from the front display panel.

5. Choose a pre-programmed setting from the front panel . A red light will illuminate next to the selected setting. Once a pre-programmed setting has been selected, the LED display will blink to alert the user that additional adjustments can be made.

*\* Please note: When choosing a setting, the LED will display a letter P followed by numbers. This represents the amount of time in minutes during which the food will be cooking.*

→ Pressing the ADJUST button will allow you to choose the consistency and texture of the food. Each pre-programmed setting is defaulted to “STANDARD” for a regular consistency of the food. To change this setting, simply press the ADJUST button until the desired setting is lit up (LIGHT for a more delicate texture, and STRONG for richer and fuller consistency.). The default time will be adjusted according to the chosen setting .

\* *This mode is not available for SLOW COOK or YOGURT.*



→ Pressing the “+” or “-” buttons will adjust the default cooking time to your preference.

6. Once the desired adjustments have been made (if any necessary), press the START button. Red indicators will blink from 1 to 7 on the front panel to indicate that the unit is pressurizing; once it has reached the right amount of pressure, the timer will start counting down on the display.

\* *You may hear hissing or sizzling sounds during the cooking process.*

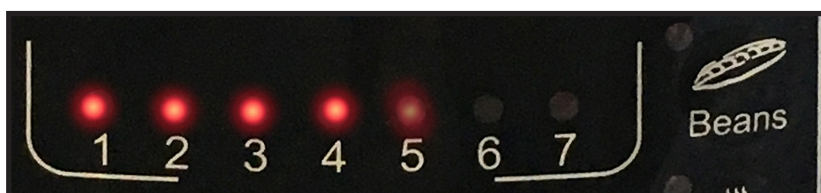

7. When cooking is completed, the pressure cooker will beep 3 times before automatically switching to “KEEP WARM/CANCEL”. The display will show “bb” and the “ KEEP WARM/ CANCEL “ button will illuminate to indicate that the cooking is completed and that the unit is now only keeping the food warm.

\* *It is not recommended to stay on the “keep warm” mode for more than 4 hours.*



- At this point, you may release the pressure before opening the lid by moving the pressure limiting valve to the “Exhaust” position. Once the pressure has released, the lid should open easily. If the lid feels tight, do not force it open and allow additional time for pressure to fully release.

**CAUTION HOT STEAM RISK OF SCALDING: USE TONGS OR LONG UTENSIL TO TURN THE VALVE. KEEP HANDS AND FACE AWAY FROM PRESSURE LIMITING VALVE WHILE IN THE EXHAUST POSITION. ALWAYS MAKE SURE THAT THE PRESSURE IS COMPLETELY RELEASED BEFORE UNLOCKING AND OPENING THE LID.**

- Press the “KEEP WARM/CANCEL” to end operation and remove food to serve immediately. The light indicator will go off and the display will show 0000 to indicate that the unit is no longer warming up the food.

You can refer to the below chart for cooking time ranges for each preset.

PRESET	DEFAULT COOKING TIME	COOKING TIME RANGE
WHITE RICE	12 mins	8-15 mins
BROWN RICE	70 mins	50-90 mins
SOUP	25 mins	15-40 mins
PORRIDGE	15 mins	10-25 mins
MULTIGRAIN	25 mins	20-60 mins
FISH	5 mins	3-10 mins
BEEF	25 mins	20-60 mins
MEAT/POULTRY	13 mins	13-60 mins
BEANS	40 mins	20-60 mins
STEW	40 mins	25-60 mins
SLOW COOK	6 hours	0.5-9.5 hours
SAUTÉ	5 mins	3-8 mins
YOGURT	12 hours	8-24 hours



## MANUALLY SETTING COOKING TIME

1. Prepare desired food and place it into the inner cooking pot. *(The food should be more than 3 pounds, or more than 6 cups.)*
2. Secure the lid onto the unit and turn it counter clockwise to lock it in place.
3. Move the pressure limiting valve side to side until it seals properly.
4. Plug the power cord into a 120V outlet. The LED screen will display 0000.



5. Press the “MANUAL” button.
6. Press the “+” or “-” in order to set the timer. The LED will display a letter P followed by numbers. This represents the amount of time in minutes during which the food will be cooking.

\* *The ADJUST mode is not available with manual settings*



7. The timer will increase or decrease by 1 minute with each press of the “+” or “-” button. Hold down the “+” and “-” buttons for faster increase/decrease of the cooking time. The timer can be set to up to 99 minutes.
8. Press the START button. Red indicators will blink from 1 to 7 on the front panel to indicate that the unit is pressurizing; once it has reached the right amount of pressure, a beep will sound and the timer will start counting down on the display.

\* *You may hear hissing or sizzling sounds during the cooking process.*



9. When cooking is completed, the pressure cooker will beep 3 times before automatically switching to “KEEP WARM/CANCEL”. The display will show “bb” and the “ KEEP WARM/CANCEL “ button will illuminate to indicate that the cooking is completed and that the unit is now keeping the food warm.  
*\* It is not recommended to stay on the “keep warm” mode for more than 4 hours.*
10. At this point, you may release the pressure before opening the lid by moving the pressure limiting valve to the “Exhaust” position. Once the pressure has released, the lid should open easily. If the lid feels tight, do not force it open and allow additional time for pressure to fully release.  
**CAUTION HOT STEAM RISK OF SCALDING: USE TONGS OR LONG UTENSIL TO TURN THE VALVE. KEEP HANDS AND FACE AWAY FROM PRESSURE LIMITING VALVE (3) WHILE IN THE EXHAUST POSITION.**  
**ALWAYS MAKE SURE THAT THE PRESSURE IS COMPLETELY RELEASED BEFORE UNLOCKING AND OPENING THE LID.**
11. Press the “KEEP WARM/CANCEL” to end operation and remove food to serve immediately. The light indicator will go off and the display will show 0000 to indicate that the unit is no longer warming up the food.

## SETTING DELAY TIMER

The delay timer is available to you if you wish to program your pressure cooker to automatically start at a later time. The delay timer can be set to delay cooking for up to 24-hours. It can be used in combination with the pre-programmed settings or with the manual setting.

### **DELAY TIMER WITH PRE-PROGRAMMED SETTINGS**

1. Press the "TIMER" button. A green light will indicate that this mode has been selected.
2. The timer will appear on the display; the minimum for delay timer is 30 minutes.



3. Use the "+" and "-" button to adjust the delayed time by 30 minutes increments.
  4. Follow steps 5 & 6 of the "USING PRE-PROGRAMMED SETTINGS" section
- \* When in delay timer mode, the unit will start pressurizing only after the delayed timer countdown has reached 0.*

*\* This mode is not available for SLOW COOK, SAUTÉ or YOGURT.*

### **DELAY TIMER WITH MANUAL SETTING**

1. Press the "TIMER" button. A green light will indicate that this mode has been selected.
2. The timer will appear on the display; the minimum for delay timer is 30 minutes.
3. Use the "+" and "-" button to adjust the delayed time by 30 minutes increments.
4. Follow steps 5 to 8 of the "MANUALLY SETTING COOKING TIME" section

*\* When in delay timer mode, the unit will start pressurizing only after the delayed timer countdown has reached 0.*

## HOW TO SAUTÉ WITH YOUR PRESSURE COOKER

Before pressure cooking, most recipes will benefit from the golden color, richer flavors and moist results gained from Browning/Sautéing.

To sauté your meats or vegetables prior to pressure cooking:

1. Remove the lid and plug in the pressure cooker.
2. Press the “SAUTÉ” button.
3. Press the ADJUST button to choose between LIGHT, STANDARD or STRONG. LIGHT is ideal for simmering, reducing juices or thickening sauces, STANDARD will allow for regular sautéing and browning of your foods, and STRONG is for stir-frying and blackening.
4. Press the “+” or “-” buttons to adjust the timer.
5. Add oil or butter as directed in your recipe and then place food into the inner pot.
6. Stir or turn food as needed until desired color and consistency is reached.
7. Press the “KEEP WARM/CANCEL” button if you want to cancel the SAUTÉ function before the timer finishes counting down.
8. If you would like to pressure cook the sautéed food, add the desired amount of liquid, place and close the lid before selecting desired program/cook time.

## COOKING FROZEN FOODS

Cooking frozen food inside a pressure cooker is quick and easy, but has certain restrictions. Only cook individual cuts of frozen meats that are up to 1 inch thick, the cooking time does not need to be altered.

*\* Please note that the pressure point may take longer to be reached when cooking frozen foods*

It is not recommended to pressure cook larger cuts of frozen meats such as a whole roast, a block of frozen ground meat or a whole chicken. Larger cuts will require increased cooking times of up to one third more, and the results may vary from meats that were completely or partially thawed and browned before cooking.

## HOW TO SLOW COOK WITH YOUR PRESSURE COOKER

1. Prepare desired food and place it into the inner cooking pot. *(The food should be more than 3 pounds, or more than 6 cups.)*
2. Cover the pressure cooker with a glass lid (not included). If you don't have a glass lid, simply place the lid on the unit, leaving it on the "open" position.

*\* We recommend purchasing a tempered glass lid which may be used for slow cooking. However, should you choose to use the original lid of the pressure cooker during the slow cooking process, please ensure the appliance is not disturbed in any way while the lid is on the unit. As it is NOT securely locked while it is being used for the slow cooking function, it may become detached from the unit allowing hot steam to escape. Please exercise **extreme caution** when removing the lid; there will be hot steam escaping the pressure cooker as is standard during any cooking process.*

3. Move the pressure limiting valve side to side until it seals properly.
4. Plug the power cord into a 120V outlet. The LED screen will display 0000
5. Press the "SLOW COOK" button. A red light will blink next to the "SLOW COOK" button and the display will blink with a defaulted time of 06:00.



6. Press the "+" or "-" in order to set the cooking time. The timer will increase or decrease by 30 minutes with each press of the "+" or "-" button. Hold down the "+" and "-" buttons for faster increase/decrease of cooking time. The timer can be set from 30 minutes to up to 9 hours and 30 minutes.

7. Press the START button. The timer will start counting down on the LED display.
8. When cooking is completed, the pressure cooker will beep 3 times before automatically switching to “KEEP WARM/CANCEL”. The display will show “bb” and the “ KEEP WARM/CANCEL “ button will illuminate to indicate that the cooking is completed and that the unit is now keeping the food warm.

*\* It is not recommended to stay on the “keep warm” mode for more than 4 hours.*

## MAKING YOGURT WITH YOUR PRESSURE COOKER

You can use your pressure cooker to make yogurt. This yogurt making process involves two steps : pasteurizing the milk, then incubating it.

In order to use your pressure cooker to make yogurt, you will need:

### TOOLS

Mesh Strainer or Nut Milk Bag  
Digital Thermometer  
Bowl  
Whisk  
Glass jars for storing

### INGREDIENTS

1 Gallon of Milk  
2 Tbs. of Starter Yogurt  
1-2 Tbs. Vanilla Extract (Optional)  
Sugar (Optional)

1. Pour the milk into the inner pot and press the “SAUTÉ” , then the “START” buttons.
2. Whisk your milk continuously during the boiling process.
3. Monitor the temperature of the milk: it should be no lower than 180°F , and no higher than 185°F. You may restart the sauté mode more than once until the desired temperature is achieved as this mode can not exceed 8 minutes of cooking time.
4. Once the desired temperature has been achieved, press the “KEEP WARM/CANCEL” button to discontinue the boiling process,
5. Remove the inner pot from the pressure cooker and set it aside for it to cool down. We recommend putting the pot in a sink filled with ice or cold water to speed up the cooling process.
6. Monitor the temperature of the milk until it reaches 110°F to 115°F. Occasionally stirring the milk inside of the pot will help it cool down.

7. Whisk in your starter yogurt once the desired temperature has been reached. Add the vanilla and sugar if desired
8. Dry off the outside of the inner pot if it was sitting in water during the cooling period, and set it back into the pressure cooker for incubation.
9. Place and close the lid and press the “YOGURT” button. The defaulted incubation time of 8 hours will appear on the LED display.
10. Press the “+” or “-” buttons to adjust the incubation time by 30 minutes increments. It is recommended to let the milk incubate for 5 to 10 hours. Shorter incubation yields sweeter and thinner yogurt whereas longer incubation will create tarter and thicker yogurt.
11. Once incubation is completed, press the “KEEP WARM/CANCEL” button, set the inner pot aside and let it cool.
12. Strain if desired using the nut milk bag or a mesh strainer .
13. Scoop into the glass jars and store.

*\* You may choose to use conventional methods for the boiling process, such as a pot on a stove-top, or using a microwave. Ensure to constantly monitor the temperature of the milk during the boiling process until it reaches 180°F -185°F.*

# CLEANING INSTRUCTIONS

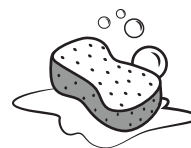

1. Always make sure the Pressure Cooker is unplugged, depressurized and completely cooled down before taking it apart.
2. Use a non-abrasive sponge or damp wash cloth to clean the exterior of the outer body and the exterior surface of the pressure cooker. NEVER immerse the pressure cooker in any liquids.
3. Clean the upper ring with a damp sponge or wash cloth.
4. Remove the filter by pulling it vertically. To re-attach, simply align it to the protrusions and push it down.



5. The pressure limiting valve pops off easily by gently pulling it up. Be careful not to damage the thin wire spring under it.
6. Clean the lid with warm soapy water, including the rubber seal ring, pressure limiting valve, filter, float valve and let dry thoroughly. Clean the pressure limiting valve and the holes with a small brush to ensure smooth flow of steam during the release cycle
7. Let parts dry completely before reassembling.
8. Wash the inner pot with a non-abrasive sponge and allow to air dry or use a towel.
9. It is not recommended to use any type of scouring pad that can scratch the surface of the inner pot.
10. Store the inner pot inside of the pressure cooker. Store the pressure cooker in a cool, dry location.

*NOTE: Any servicing required shall be performed by an authorized service representative or from the original manufacturer or distributor.*

## HELPFUL TIPS



- Read this manual thoroughly and follow all instructions.
- Be familiar with the recipe and have all ingredients prepped before you begin.
- Be sure the lid is secured and locked properly before beginning.
- You may wish to brown some meats before cooking with other ingredients.
- Cut foods into equal-sized pieces to promote even cooking. In recipes that call for multiple ingredients, cut those that cook more quickly into larger pieces and those that take longer to cook into smaller pieces.
- A large variety of liquids can be used for pressure cooking, such as wine, beer, bouillon, fruit juices, water, broth and more.
- After becoming familiar with your pressure cooker, you can adapt conventional recipes to be used with it. As a general rule, cut cooking times of your conventional recipes by two thirds. The amount of liquid used may also have to be reduced because there is very little evaporation in the pressure cooker. Remember, however, there must always be some liquid in the pressure cooker to produce the necessary steam. As a rule of thumb, add 1 cup of liquid for the first 15 minutes of pressure cooking then 1/3 cup of liquid for each subsequent 15 minutes. This rule may vary depending on the type and amount of food cooked.
- In the event that the unit is unable to build pressure, simply add more liquid until it can pressurize.
- Since pressure cooking enhances flavors, we recommend reducing the amounts of herbs and seasonings when adapting conventional recipes.
- The use of fresh herbs is recommended as they will have a more intense flavor than dried herbs.
- In general, pressure cookers cook foods in about 1/3 of the time of conventional cooking methods.
- Increase cooking times by about 10% when cooking in high altitudes of over 3,500 feet.
- If you wish to cook food in less time than the pre-programmed timer default setting, observe the timer and press CANCEL when you would like to stop the cooking process before the timer has reached 0.