

# Service Handbook

## RESIDENTIAL GAS WATER HEATERS



**Lochinvar**<sup>®</sup>  
HIGH EFFICIENCY BOILERS & WATER HEATERS

POWER VENTED GAS MODELS  
WITH HOT SURFACE IGNITION  
*NOT FOR USE IN MANUFACTURED (MOBILE) HOMES*



**Note:** References to the *Manual* refer to the “Installation and Operating Manual.”

# CONTENTS

|  |           |  |           |
|--|-----------|--|-----------|
| <b>GENERAL INFORMATION</b> .....                       | <b>3</b>  | Door Gasket.....                                       | 16        |
| Terminology.....                                       | 3         | Removing Inner Door/Manifold/Burner Assembly.....      | 16        |
| Formulas and Conversions.....                          | 3         | Removing The Door Gasket.....                          | 17        |
| <b>CHECKING THE GAS SUPPLY PRESSURE</b> .....          | <b>4</b>  | Replacing The Door Gasket.....                         | 17        |
| <b>LEAKAGE CHECKPOINTS</b> .....                       | <b>5</b>  | Re-installing Inner Door/Manifold/Burner Assembly..... | 17        |
| <b>TEMPERATURE ADJUSTMENT</b> .....                    | <b>6</b>  | <b>CONTROL MODULE REMOVAL/REPLACEMENT</b> .....        | <b>18</b> |
| Safety.....  | 6         | Electronic Control Module.....                         | 18        |
| Settings.....  | 6         | Removing Electronic Control Module.....                | 18        |
| <b>ANODE ROD REMOVAL/REPLACEMENT</b> .....             | <b>7</b>  | <b>VALVE MODULE REMOVAL/REPLACEMENT</b> .....          | <b>20</b> |
| Anode Rod.....   | 7         | Valve Module.....                                      | 20        |
| Removing Anode Rod:.....                               | 7         | Removing Valve Module.....                             | 20        |
| Installing Anode Rod:.....                             | 7         | <b>TEMPERATURE SENSOR AND</b>                          |           |
| <b>DIP TUBE REMOVAL/REPLACEMENT</b> .....              | <b>8</b>  | <b>CABLE REMOVAL/REPLACEMENT</b> .....                 | <b>21</b> |
| Dip Tube.....  | 8         | Temperature Sensor and Cable.....                      | 21        |
| Removing Dip Tube:.....                                | 8         | Removing Temperature Sensor and Cable.....             | 21        |
| Installing Dip Tube:.....                              | 8         | <b>GAS VALVE REMOVAL/REPLACEMENT</b> .....             | <b>22</b> |
| <b>DOOR-BURNER ASSEMBLY REMOVAL/REPLACEMENT</b> ....   | <b>9</b>  | Removing Gas Control Valve.....                        | 22        |
| Inner Door/Manifold/Burner Assembly.....               | 9         | Installing Gas Control Valve.....                      | 22        |
| Removing Inner Door/Manifold/Burner Assembly.....      | 9         | <b>BLOWER REMOVAL/REPLACEMENT</b> .....                | <b>23</b> |
| Re-installing Inner Door/Manifold/Burner Assembly..... | 9         | BLOWER.....  | 23        |
| <b>FLAME SENSOR AND IGNITER REMOVAL/REPLACEMENT.</b>   | <b>11</b> | Removing Blower.....                                   | 23        |
| Flame Sensor and/or Hot Surface Igniter.....           | 11        | Installing Blower.....                                 | 23        |
| Removing Inner Door/Manifold/Burner Assembly.....      | 11        | <b>ROTATING THE BLOWER</b> .....                       | <b>24</b> |
| Removing Flame Sensor And/Or Hot Surface Igniter.....  | 11        | BLOWER EXHAUST DIRECTION.....                          | 24        |
| Re-installing Inner Door/Manifold/Burner Assembly..... | 11        | <b>PRESSURE SWITCH REMOVAL/REPLACEMENT</b> .....       | <b>25</b> |
| <b>BURNER AND ORIFICE REMOVAL/REPLACEMENT</b> .....    | <b>13</b> | PRESSURE SWITCH.....                                   | 25        |
| BURNER.....  | 13        | Removing Pressure Switch.....                          | 25        |
| Removing Inner Door/Manifold/Burner Assembly.....      | 13        | Installing Pressure Switch.....                        | 25        |
| Removing Burner.....                                   | 13        | <b>FV SENSOR</b> .....                                 | <b>26</b> |
| Installing Burner:.....                                | 13        | FLAMMABLE VAPOR SENSOR.....                            | 26        |
| Reinstalling Inner Door/Manifold/Burner Assembly.....  | 13        | <b>CLEANING THE COMBUSTION CHAMBER</b> .....           | <b>26</b> |
| <b>BURNER ORIFICE</b> .....                            | <b>15</b> | <b>CLEANING THE BLOWER</b> .....                       | <b>27</b> |
| Removing Inner Door/Manifold/Burner Assembly.....      | 15        | BLOWER.....  | 27        |
| Removing Burner Orifice.....                           | 15        | <b>TECHNICAL BULLETINS</b> .....                       | <b>28</b> |
| Installing Burner Orifice.....                         | 15        | <b>TROUBLESHOOTING CHART</b> .....                     | <b>34</b> |
| Reinstalling Inner Door/Manifold/Burner Assembly.....  | 16        | <b>GAS CONTROL LED STATUS CODES</b> .....              | <b>36</b> |
| <b>DOOR GASKET REPLACEMENT</b> .....                   | <b>16</b> | <b>IGNITION STATE AND TIMING</b> .....                 | <b>37</b> |

## GENERAL INFORMATION

### TERMINOLOGY

**Draw efficiency** is the quantity of hot water available to the consumer before the outlet water temperature decreases by 25F° (14C°). A 40 gallon water heater will typically provide 70% (28 gallons) of this “usable” hot water (60% is the minimum). The burner or elements are allowed to operate during this test. Incoming, cold water mixes the remaining stored water below this 25F° (14C°) limitation.

**Energy Factor** is an indicator of the combined thermal efficiency and standby efficiency of a water heater. The higher the energy factor, the more efficient the water heater will be.

**Minerals and gases** will separate from water as temperature increases.

**“R” Value** is a measure of the resistance of a substance to heat flow.

**Recovery rate** is the amount of water that is heated to a set temperature, per hour.

**Standby efficiency** is the water heater’s ability to contain heat in the tank. A minimum of tank water heat loss per hour is desired. For example: temperature change/“R” value = Btu/h loss/square foot of tank surface

**Temperature rise** is the increase in the temperature from its coldest “inlet” water temperature to the desired hot (outlet) setting. Typically it is assumed that the entering water be 40°F (5°C), stored water desired to be 120°F (49°C) resulting in a “temperature rise” of 80F° (44C°).

**Thermal efficiency** is approximately the amount of generated BTU (British Thermal Units), which enters the water. A percentage of the total BTU passes out through the vent piping.

Water cannot (for all practical purposes) be compressed.

Water expands when it is heated.

### FORMULAS AND CONVERSIONS

- BTU (British Thermal Unit) is the heat required to raise one pound of water 1F°
- 1 BTU = 252 cal = 0.252 kcal
- 1 cal = 4.187 Joules
- BTU X 1.055 = Kilo Joules
- BTU divided by 3,413 = Kilowatts
- To convert from Fahrenheit to Centigrade: (°F – 32) times 5/9, or .556, equals degrees C.
- One gallon of (120°F, 49°C) water weighs approximately 8.25 pounds.
- Pounds X .45359 = Kilogram
- Gallons X 3.7854 = Liters
- % of Hot = (Mixed Temp. – Cold) divided by (Hot Temp. – Cold)
- % Thermal Efficiency = (GPH X 8.25 X Temp. Rise X 1.0) divided by BTU/H Input
- BTU Output = GPH X 8.25 X Temp. Rise X 1.0
- GPH = (BTU/H Input X % Eff.) divided by (Temp. Rise X 8.25)
- One cubic foot of Natural Gas contains about 1000 BTU of heat.
- One “therm” is equal to 100,000 BTU
- One cubic foot of Propane Gas contains about 2500 BTU of heat.
- One gallon of Propane gas contains about 91,250 BTU of heat.
- One pound of Propane gas contains about 21,600 BTU of heat.
- One pound of gas pressure is equal to 27.7 inches water column pressure
- Inches of Water Column X .036091 = PSI
- Inches of Water Column X .073483 = Inches of Mercury (Hg.)
- Centimeters = Inches X 2.54
- mm (millimeters) = Inches X 25.4
- Meters = Inches X .0254
- Doubling the diameter of a pipe will increase its flow capacity (approximately) 5.3 times.

**Construction:** Tank is constructed of steel. The inside of the tank is constructed of a glass lining bonded to the steel. This prevents water to metal contact and rusting of the tank. An anode rod will be installed within the tank. The hex-head plug end of the anode is visible on the top of the water heater. This metal rod offers secondary protection of the tank against corrosion where the application of glass is not possible (threaded tank openings). These areas will have small areas of water to metal contact.

All water heaters will contain at least one thermostat (to operate the heater) and one high limit (to prevent water from overheating).

## CHECKING THE GAS SUPPLY PRESSURE

Gas pressure checks are done with flowing gas using a gas pressure manometer capable of reading pressure in inches of water column.

Supply gas pressure checks are measured before the gas control valve and as close to the water heater as possible. Manifold (main burner) gas pressure is measured at the pressure tap on the bottom of the gas control valve. See **Figure 1**. Use an Allen wrench to remove the plug, then attach the gas gauge.

**Note:** Desired gas pressures will be noted on the gas valve label located on the gas control valve and rating plate.

| IF   | THEN   |
|--|--|
| Supply gas pressure is under desired pressure requirement  | <ul style="list-style-type: none"> <li>• Increase supply gas pressure regulator setting.</li> <li>• Call the gas utility company to readjust gas pressure on main supply. Technicians can not adjust main gas supply pressure.</li> </ul>  |
| Supply gas pressure is over desired pressure   | <ul style="list-style-type: none"> <li>• Add gas pressure regulator.</li> <li>• Call the gas utility company to readjust gas pressure on main supply. Technicians can not adjust main gas supply pressure.</li> </ul>  |
| Manifold gas pressure is more than +/- .4 inch W.C. from values indicated on gas valve or rating plate | <ul style="list-style-type: none"> <li>• Ensure there is adequate supply gas pressure.</li> <li>• Ensure the main burner orifice is the correct size for the water heater model being tested.</li> <li>• If the above tests have been performed and the results were correct replace the gas control valve.</li> </ul> |

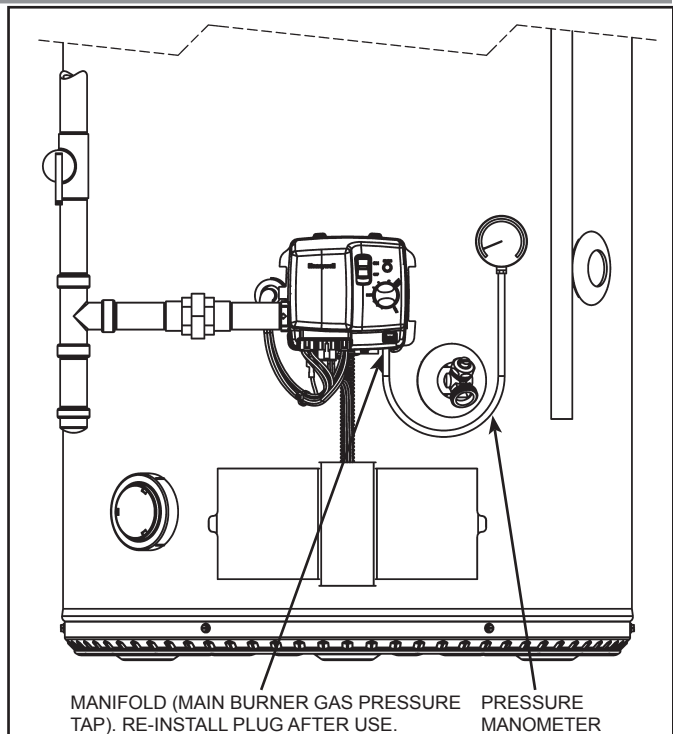

**Figure 1. Pressure Tap and Manometer**

**Important:** After checking the manifold gas pressure, detach the gas gauge, reinstall the plug using insulation tape and tighten with Allen wrench. Check for leaks and repair as required.

## LEAKAGE CHECKPOINTS

- A. Water at the blower assembly is water vapor which has condensed out of the combustion products. This is caused by a problem in the vent or blockage in the drain coupling.
  - B. Condensation may be seen on pipes in humid weather or pipe connections may be leaking.
  - C. The anode rod fitting may be leaking.
  - D. Small amounts of water from temperature-pressure relief valve may be due to thermal expansion or high water pressure in your area.
  - E. \*The temperature-pressure relief valve may be leaking the tank fitting.
  - F. Water from a drain valve may be due to the valve being slightly opened.
  - G. The drain valve may be leaking at the tank fitting.
  - H. Combustion products contain water vapor which can condense on the cooler surfaces of the tank. Droplets form and drip onto the burner. This is common at the time of start-up after installation and when incoming water is cold.
  - I. Water in the water heater bottom or on the floor may be from condensation. **DO NOT** replace the water heater until a full inspection of all possible water sources is made and necessary corrective steps taken.
  - J. Leakage from other appliances, water lines, or ground seepage should also be checked.
- \* To check where threaded portion enters tank, insert cotton swab between jacket opening and fitting. If cotton is wet, follow draining instructions in **Draining and Flushing** in the **Manual** and then remove fitting. Put pipe dope or Teflon® tape on the threads and replace. When you are finished, follow the steps in **Filling the Water Heater** in the **Manual**.

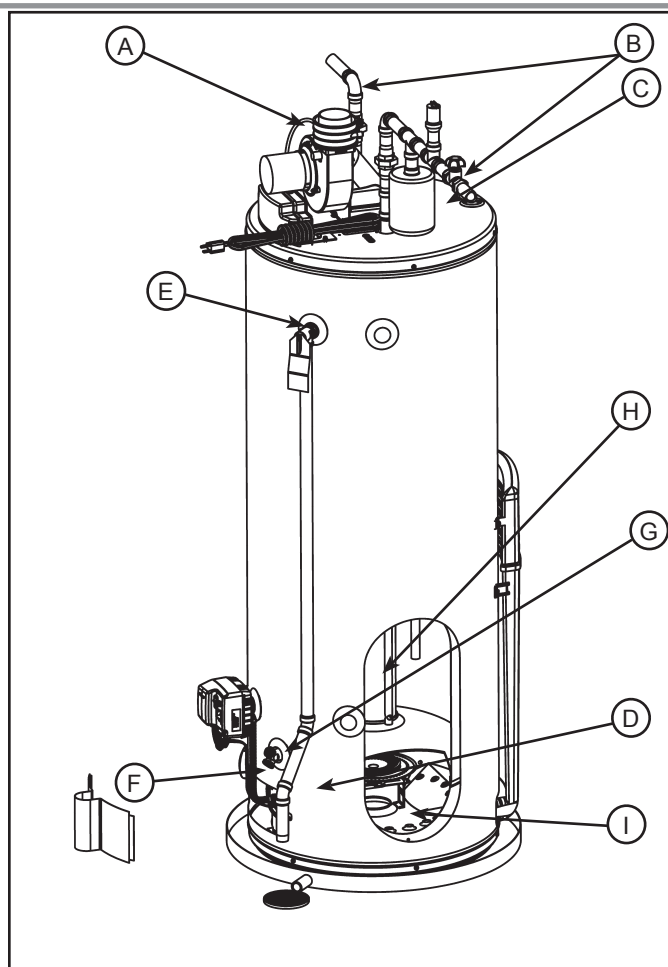

Figure 2. Leakage Test Points

# TEMPERATURE ADJUSTMENT

## SAFETY

Due to the nature of the typical gas water heater, the water temperature in certain situations may vary up to 30F° (16C°) higher or lower at the point of use such as bathtubs, showers, sink, etc.

**HOT WATER CAN SCALD:** Water heaters are intended to produce hot water. Water heated to a temperature which will satisfy space heating, clothes washing, dish washing, and other sanitizing needs can scald and permanently injure you upon contact. Some people are more likely to be permanently injured by hot water than others. These include the elderly, children, the infirm, or physically/mentally handicapped. If anyone using hot water in your home fits into one of these groups or if there is a local code or state law requiring certain temperature water at the hot water tap, then you must take special precautions.

In addition of using the lowest possible temperature setting that satisfies your hot water needs, a means such as a mixing valve should be used at the hot water taps used by these people or at the water heater. Mixing valves are available at plumbing supply or hardware stores. Follow manufacturer's instructions for installation of the valves. Using the lowest hot water temperature that meets your needs will also provide the most energy efficient operation of the water heater.

Never allow small children to use a hot water tap, or to draw their own bath water. Never leave a child or handicapped person unattended in a bathtub or shower.

**Note:** A water temperature range of 120°F-140°F (49°C-60°C) is recommended by most dishwasher manufacturers.

## SETTINGS

Temperature range on residential gas water heater is from 110°F ±10° to 155°F ±10° and a 70°F vacation setting. The T&P valve will open at 195°F ± 10°.

The water heater temperature adjusting dial is factory set at the lowest temperature, all the way counter-clockwise to the mechanical stop, unless specified differently by provincial or state regulations. See **Figure 3**. It is adjustable and must be reset to the desired temperature setting to reduce the risk of scald injury. Turning the dial clockwise will increase the temperature and counter-clockwise will reduce the temperature. The HOT marking on the Honeywell gas valve is indicative of approximately 120°F (49°C) and is the preferred starting point. Some states have a requirement for a lower setting. Should overheating occur or the gas supply fails to shut off, turn "OFF" the manual gas control valve to the water heater.

The following table lists the approximate water temperatures produced by various dial settings. Short repeated heating cycles caused by small hot water uses can cause temperatures at the point of use to exceed the thermostat setting by up to 30F° (16C°). If you experience this type of use, you should consider using lower temperature settings to reduce scald hazards. Listed below is time-to-burn relationship for normal adult skin.

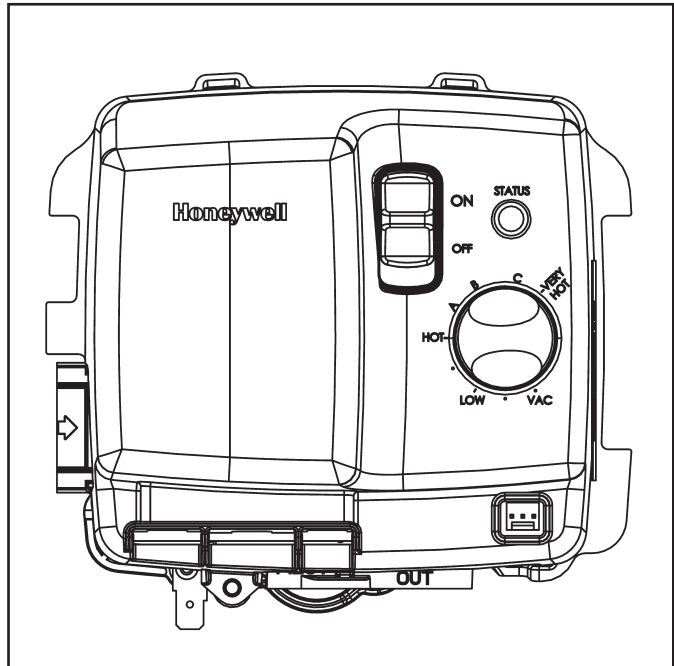

Figure 3. Temperature Adjusting Dial

| Table 1. Time to Burn at Various Temperatures |                                 |  |
|---|---------------------------------|--|
| Temperature Setting                           | Approximate Temperature °F (°C) | Time to reduce a 2nd and 3rd Degree burn to adult skin |
| VERY HOT                                      | 155 (68)                        | Less than 1 second                                     |
| C   | 150 (65)                        | About 1.5 seconds                                      |
| B   | 140 (60)                        | Less than 5 seconds                                    |
| A   | 130 (54)                        | More than 30 seconds                                   |
| HOT   | 120 (49)                        | More than 5 minutes                                    |
| LOW   | 110 (43)                        | Normal shower temp                                     |
| VAC   | 70 (21)                         | N/A  |

# ANODE ROD REMOVAL/REPLACEMENT

## ANODE ROD

**Important:** Use only factory authorized replacement parts. If you lack the necessary skills to properly perform the installation, you should not proceed, but get help from a qualified service technician.

### Tools Required

- Ratchet with 1-1/16" Socket
- Pliers
- Teflon® Tape or an approved pipe sealant

### REMOVING ANODE ROD:

1. Set the gas control valve/thermostat to its lowest setting by turning the knob counter-clockwise to the VAC point. See *Figure 3* (page 6).
2. Turn gas control switch to the "OFF" position and turn "OFF" the gas supply to the unit. See *Figure 3* (page 6).
3. Disconnect the electrical power to the water heater from the wall outlet.
4. Shut off the incoming water supply to the water heater and open a nearby hot-water faucet to depressurize the water tank.
5. Connect a hose to the drain valve and terminate it to adequate drain or to the exterior of the building. Open the drain valve and allow at least 5 gallons of water to drain from the tank. Close drain and remove hose.
6. Remove and retain the anode cap on top of the heater and remove and retain just enough insulation so you can access to the anode head. See *Figure 4*. Keep in a safe place for reinstallation later.
7. Remove the anode rod by using a ratchet and a 1-1/16" socket turning counter-clockwise. See *Figure 4*.

### INSTALLING ANODE ROD:

1. Use Teflon® tape or an approved pipe sealant on threads of the new anode rod.
2. Place the anode rod in the spud (top of the tank) and turn clockwise until the threads are hand tight. Using a ratchet and 1-1/16" socket tighten down water tight.
3. Turn the main water supply back on.
4. Open a nearby hot-water faucet to purge air from the water line. Fill water heater tank completely

**Note:** To assure the water heater tank is full, keep the hot-water faucet open for 3 minutes after a constant flow of water is obtained).

5. After turning off the hot-water faucet, check for water leaks around anode rod and immediately correct any if found.
6. Reinstall the insulation and anode cap which were removed in step 6 above.
7. Reconnect the electrical power to the water heater in the wall outlet and turn the main gas supply back "ON" to the gas control valve/thermostat.
8. Turn the gas control switch to the "ON" position. See *Figure 3* (page 6).
9. To restart the water heater, follow the directions on the *Lighting and Operating Instructions* label located on the front of the water heater near the gas control valve/thermostat.

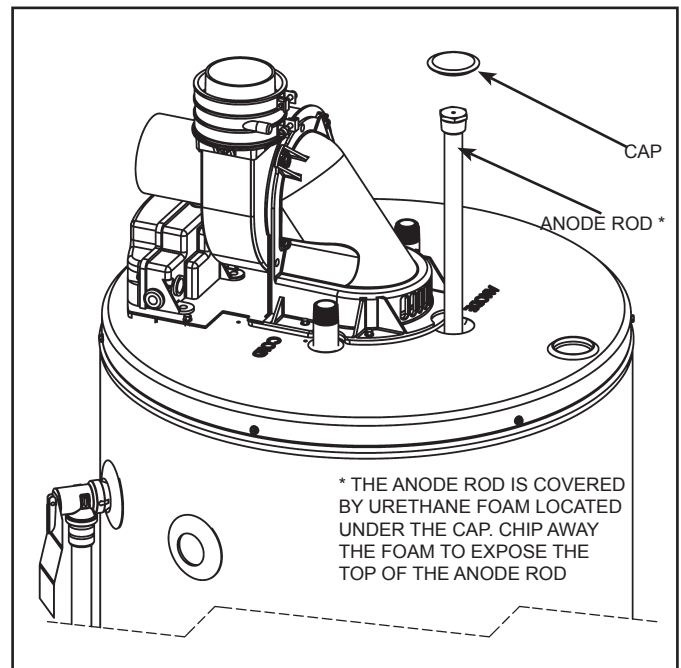

Figure 4. Removing the Anode Cap and Anode Rod

# DIP TUBE REMOVAL/REPLACEMENT

## DIP TUBE

**Important:** Use only factory authorized replacement parts. If you lack the necessary skills to properly perform the installation, you should not proceed, but get help from a qualified service technician.

### Tools Required

- 18" Pipe wrench
- Piping and soldering equipment
- Teflon® Tape or an approved pipe sealant

## REMOVING DIP TUBE

1. Set the gas control valve/thermostat to its lowest setting by turning the knob counter-clockwise to the VAC point. See **Figure 3** (page 6).
2. Turn gas control switch to the "OFF" position and turn "OFF" the gas supply to the unit. See **Figure 3** (page 6).
3. Disconnect the electrical power to the water heater from the wall outlet.
4. Shut off the incoming water supply to the water heater and open a nearby hot-water faucet to depressurize the water tank. Remove pipe insulation from cold inlet piping.
5. Connect a hose to the drain valve and terminate it to adequate drain or to the exterior of the building. Open the drain valve and allow at least 5 gallons of water to drain from the tank. Close drain and remove hose.
6. Remove the inlet water piping connected to the cold inlet of the water heater. See **Figure 5** & **Figure 6**. Some installations will have a union connection, others will have the supply piping soldered to an adapter that connects to the nipple on the water heater. Using the pipe wrench remove the piping from the top of the tank.
7. With the piping removed, use the pipe wrench on the exposed nipple directly to remove it from the heater.

**Note:** Sometimes the dip tube will come out with the piping in one piece. Separate accordingly.

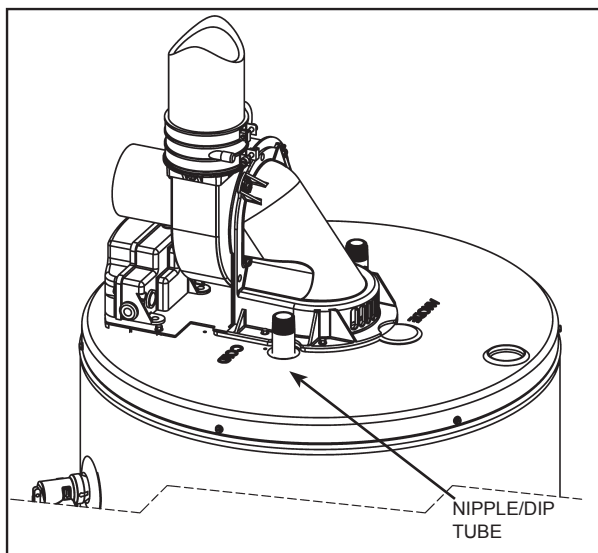

Figure 5. DIP Tube (Inlet Piping)

## INSTALLING DIP TUBE

1. Use Teflon® tape or an approved pipe sealant on threads of the new dip tube.
2. Place the dip tube into the spud on top of the tank and turn clockwise until tight. Using the pipe wrench continue to tighten until the joint is water tight.

**Note:** Do not clamp the pipe wrench jaws on the threaded portion of the nipple and do not over tighten. This can cause the threads to distort and can result in a leak.

3. Apply Teflon® tape or pipe sealant on the top threads and reconnect the water piping. See **Figure 6**.
4. Turn the main water supply back on.
5. Open a nearby hot-water faucet to purge air from the water line. Fill water heater tank completely

**Note:** To assure the water heater tank is full, keep the hot-water faucet open for 3 minutes after a constant flow of water is obtained.

6. After turning off the hot-water faucet, check for water leaks around dip tube and immediately correct any if found.
7. Reinstall the pipe insulation removed in step 4 removal process.
8. Reconnect the electrical power to the water heater in the wall outlet and turn the gas supply back "ON" to the gas control valve/thermostat.
9. Turn the gas control switch to the "ON" position. See **Figure 3** (page 6).
10. To restart the water heater, follow the directions on the **Lighting and Operating Instructions** label located on the front of the water heater near the gas control valve/thermostat.

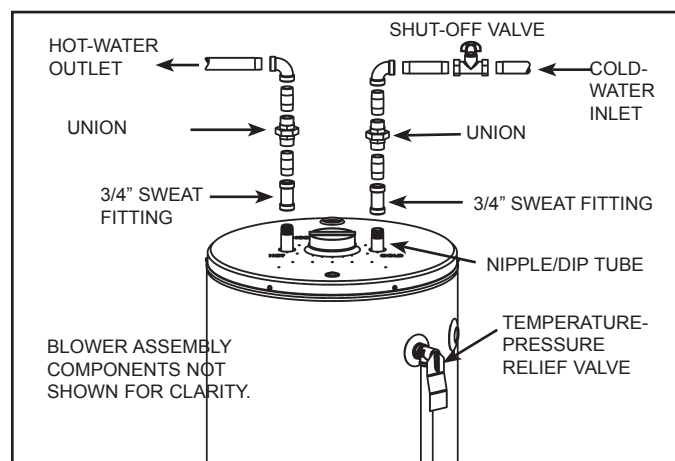

Figure 6. Inlet Piping with Union Connectors

# DOOR-BURNER ASSEMBLY REMOVAL/REPLACEMENT

## INNER DOOR/MANIFOLD/BURNER ASSEMBLY

**Important:** Use only factory authorized replacement parts. If you lack the necessary skills to properly perform the installation, you should not proceed, but get help from a qualified service technician.

### Tools required:

- 3/4" Open-End Wrench
- Phillips Head Screwdriver
- Ratchet with 1/4" socket or 1/4" nut-driver
- Flashlight

## REMOVING INNER DOOR/MANIFOLD/BURNER ASSEMBLY

1. Set the gas control valve/thermostat to its lowest setting by turning the knob counter-clockwise to the VAC point. See *Figure 3* (page 6).
2. Turn gas control switch to the "OFF" position and turn "OFF" the gas supply to the unit. See *Figure 3* (page 6).
3. Disconnect the electrical power to the water heater from the wall outlet.
4. Remove the outer door from the unit.
5. Unplug all the electrical connections from the bottom of the gas control valve/thermostat. See *Figure 7*.
6. Using a 3/4" open end wrench remove the manifold tube from the gas control valve/thermostat (turning counter-clockwise for natural gas, clockwise for LP). Grasp the manifold tube and push down slightly to free the manifold tube from the gas control valve/thermostat. See *Figure 7*.
7. Remove the insulation pad on the inner door by cutting it if necessary. Keep the insulation in a safe place for reusing it later.
8. Use a 1/4" nut-driver or 1/4" socket & ratchet to loosen the 2 hex head screws on the inner door so the inner door/manifold/burner assembly can be removed. See *Figure 7*.
9. Remove inner door/manifold/burner assembly by grasping the manifold and pull back slowly. Rotating it to the left to clear the igniter and flame sensor. Care should be taken when inner door and burner assembly passes through jacket opening that it does not damage any of the electrical wiring. See *Figure 9* (page 10).

### Caution Must Be Taken

Prior to installing the new inner door/manifold/burner, look inside the burner chamber to fully understand the correct positioning of the burner assembly and burner manifold tab. It is necessary to use a flashlight to ensure correct placement. Care must be taken so as to not damage any electrical wiring or components as you are installing the new inner door/manifold/burner assembly.

Extra caution should be taken to ensure that electrical wiring, fiberglass insulation or any other object is not between door gasket and combustion chamber shield.

**Note:** If the burner door gasket is worn or damaged it needs to be replaced. See *Replacing The Door Gasket*. (page 3). See *Figure 9* (page 10).

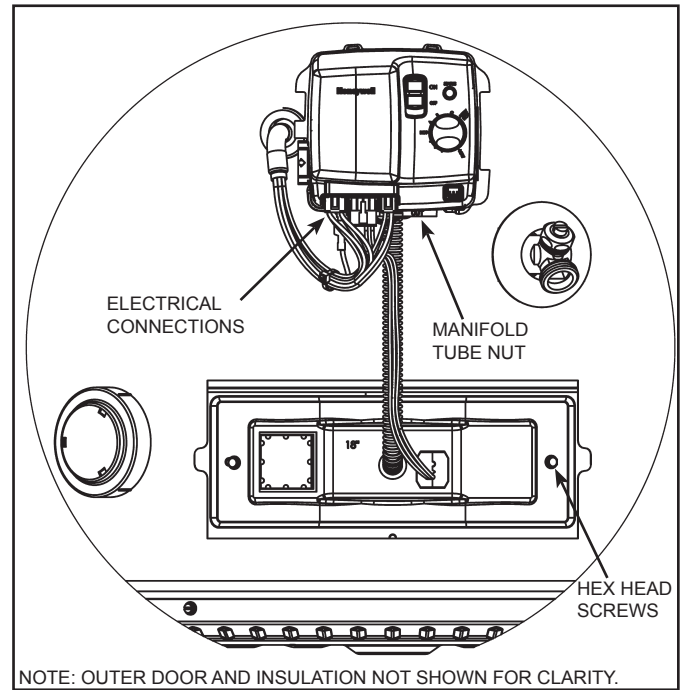

Figure 7. Electrical Connections at the Bottom of the Gas Valve

## RE-INSTALLING INNER DOOR/MANIFOLD/BURNER ASSEMBLY

1. Insert the manifold/burner assembly in the burner chamber compartment, making sure that the tip of burner manifold tab engages in the proper slot of the bracket. See *Figure 8* (page 10).

### Important:

- The tip end of the burner manifold **MUST** be placed in the **upper** slotted portion for models with input rate of 40,000 to 50,000 Btu/hr to obtain proper installation.
  - The tip end of the burner manifold **MUST** be placed in the **lower** slotted portion for models with input rate of 60,000 to 75,000 Btu/hr to obtain proper installation.
2. After confirming no materials of any type are between door gasket and combustion chamber shield, align the screws on the inner door with the screw holes on the combustion chamber and tighten with 1/4" nut-driver or 1/4" socket & ratchet. See *Figure 7*.

After tightening the inner door screws, visually inspect area around door gasket and skirt for spaces or gaps. The door gasket **MUST** be sealed completely in order for the water heater to perform properly. **DO NOT OPERATE THE WATER HEATER IF THE DOOR GASKET DOES NOT CREATE A SEAL BETWEEN MANIFOLD DOOR AND COMBUSTION CHAMBER.**

- Reconnect the manifold tube to the gas control valve/thermostat.

**Note:** Do Not apply any thread sealant at this connection). To prevent any cross threading the manifold tube should be started by hand (turn clockwise for natural gas, counter-clockwise for LP). Upon tightening with the fingers and confirming it has not been cross threaded, tighten nut with a 3/4" open end wrench. See *Figure 7* (page 8).

- Reinstall the insulation pad which was removed in step 7 above.
- Reconnect all the electrical connections to the bottom of the gas control valve/thermostat, gently pushing each connector up until it snaps into place. See *Figure 7* and *Figure 10*.
- Reconnect the electrical power to the water heater in the wall outlet and turn the main gas supply back "ON" to the gas control valve/thermostat.
- Restart the water heater by following the directions on the *Lighting and Operating Instructions* label located on the front of the water heater. Test gas connections by brushing on an approved non-corrosive leak detection solution.

**Note:** Do not splash the solution on control. If a leak is detected, shut the water heater down by following the directions on the *Lighting and Operating Instructions*. Repair the leak(s) and repeat this step.

- Upon verifying proper operation of the water heater, replace the insulation and outer door.

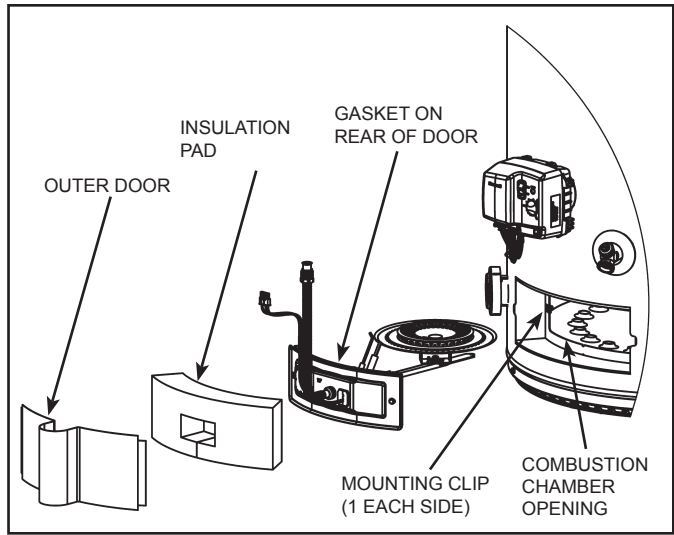

Figure 9. Burner Chamber Compartment Doors

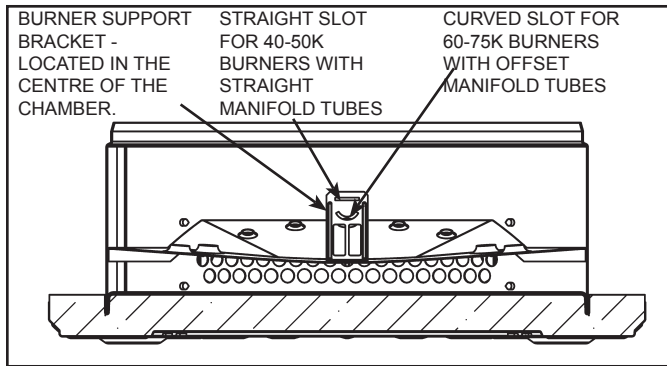

Figure 8. Manifold/Burner Assembly

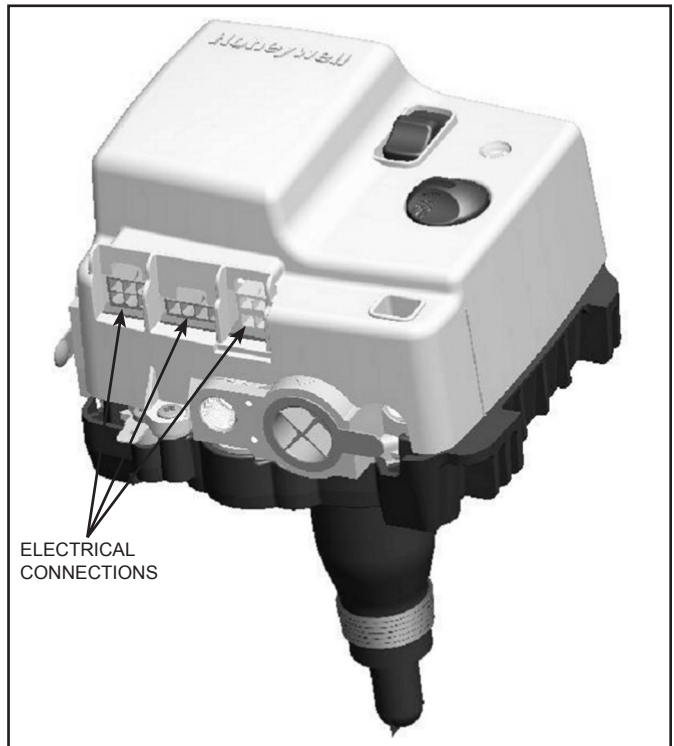

Figure 10. Electrical Connections on the Gas Valve

# FLAME SENSOR AND IGNITER REMOVAL/REPLACEMENT

## FLAME SENSOR AND/OR HOT SURFACE IGNITER

**Important:** Use only factory authorized replacement parts. If you lack the necessary skills to properly perform the installation, you should not proceed, but get help from a qualified service technician.

### Tools Required

- 3/4" Open-End Wrench
- Phillips Head Screwdriver
- Ratchet with 1/4" socket or 1/4" nut-driver
- Flashlight
- Flat Blade screwdriver

## REMOVING INNER DOOR/MANIFOLD/BURNER ASSEMBLY

1. Set the gas control valve/thermostat to its lowest setting by turning the knob counter-clockwise to the VAC point. See *Figure 3* (page 6).
2. Turn gas control switch to the "OFF" position and turn "OFF" the gas supply to the unit. See *Figure 3* (page 6).
3. Disconnect the electrical power to the water heater from the wall outlet.
4. Remove the outer door from the unit.
5. Unplug all the electrical connections from the bottom of the gas control valve/thermostat. See *Figure 11* (page 12).
6. Using a 3/4" open end wrench remove the manifold tube from the gas control valve/thermostat (turning counter-clockwise for natural gas, clockwise for LP). Grasp the manifold tube and push down slightly to free the manifold tube from the gas control valve/thermostat. See *Figure 11* (page 12).
7. Remove the insulation pad on the inner door by cutting it if necessary. Keep the insulation in a safe place for reusing it later.
8. Use a 1/4" nut-driver or 1/4" socket & ratchet to loosen the 2 hex head screws on the inner door so the inner door/manifold/burner assembly can be removed. See *Figure 11* (page 12).
9. Remove inner door/manifold/burner assembly by grasping the manifold, rotating it to the left to clear the igniter and flame sensor and pulling back. Care should be taken when inner door and burner assembly passes through jacket opening that it does not damage any of the electrical wiring. See *Figure 13* (page 8).

## REMOVING FLAME SENSOR AND/OR HOT SURFACE IGNITER

**Note:** The configuration of the flame sensor and igniter allows you to replace them separately. It is recommended to clean the flame sensor when you replace the igniter.

1. Lift the retainer clip straight up from the back of the manifold component block (using a flat-blade screwdriver), then remove the manifold component block from the manifold door. See *Figure 14* (page 12).
2. Disconnect the wiring connection between the flame sensor/igniter and valve.

3. Remove and retain the screw(s) securing the flame sensor and/or hot surface igniter assembly. See *Figure 14* (page 12).
4. Remove and discard the old flame sensor and/or hot surface igniter assembly.
5. Install the new Flame Sensor and/or Hot Surface Igniter.
6. Route the new flame sensor and/or hot surface igniter connector wire through manifold/burner door opening. Secure the assembly to the bracket using screw(s) removed in step 3 above.
7. Reconnect the wiring connection between the flame sensor/igniter and the valve.
8. Reposition the manifold component block in the manifold door opening and secure it with the retainer clip.

## Caution Must Be Taken

Prior to installing the new inner door/manifold/ burner assembly, look inside the burner chamber to fully understand the correct positioning of the burner assembly and burner manifold tab. It may be necessary to use a flashlight to ensure correct placement. Care must be taken so as to not damage any electrical wiring or components as you are installing the new inner door/manifold/burner assembly.

Extra caution should be taken to ensure that electrical wiring, fiberglass insulation or any other object is not caught between door gasket and combustion chamber shield.

**Note:** If the burner door gasket is worn or damaged it needs to be replaced. See *Replacing The Door Gasket*. (page 3). See also *Figure 9* (page 8).

## RE-INSTALLING INNER DOOR/MANIFOLD/BURNER ASSEMBLY

1. Insert the manifold/burner assembly in the burner chamber compartment, making sure that the tip of burner manifold tab engages in the proper slot of the bracket. See *Figure 12* (page 12). The tip end of the burner manifold **MUST** be placed in the slotted portion under the condensation pan to obtain proper installation.

**Important:**

- The tip end of the burner manifold **MUST** be placed in the **upper** slotted portion for models with input rate of 40,000 to 50,000 Btu/hr to obtain proper installation.
- The tip end of the burner manifold **MUST** be placed in the **lower** slotted portion for models with input rate of 60,000 to 75,000 Btu/hr to obtain proper installation.

2. After confirming no materials of any type are between door gasket and combustion chamber shield, align the screws on the inner door with the screw holes on the combustion chamber and tighten with 1/4" nut-driver or 1/4" socket & ratchet. See *Figure 11* (page 12).

After tightening the inner door screws, visually inspect area around door gasket and skirt for spaces or gaps. The door gasket **MUST** be sealed completely in order for the water heater to perform properly.

**DO NOT OPERATE THE WATER HEATER IF THE DOOR GASKET DOES NOT CREATE A SEAL BETWEEN MANIFOLD DOOR AND COMBUSTION CHAMBER.**

- Reconnect the manifold tube to the gas control valve/thermostat.

**Note:** Do Not apply any thread sealant at this connection. To prevent any cross threading the manifold tube should be started by hand (turn clockwise for natural gas, counter-clockwise for LP). Upon tightening with the fingers and confirming it has not been cross threaded, tighten nut with an 3/4" open end wrench. See *Figure 11* (page 12).

- Reconnect all the electrical connections to the bottom of the gas control valve/thermostat, gently pushing each connector up until it snaps into place. See *Figure 10* and *Figure 11* (page 12).
- Reconnect the electrical power to the water heater in the wall outlet and turn the main gas supply back "ON" to the gas control valve/thermostat.
- Restart the water heater by following the directions on the *Lighting and Operating Instructions* label located on the front of the water heater.
- As the burner is heating (view flames through view-port), test the manifold tube connection at the gas control valve/thermostat by brushing on an approved noncorrosive leak detection solution.

**Important:** Do Not splash the solution onto any electrical connections. If a leak is detected, shut the water heater down by following the directions on the *Lighting and Operating Instructions*. Repair the leak(s) and repeat step 6 above).

- Upon verifying proper operation of the water heater, reinstall the insulation and the outer door.

**Note:** The structure of flame sensor/hot surface igniter allows you to remove and replace them separately.

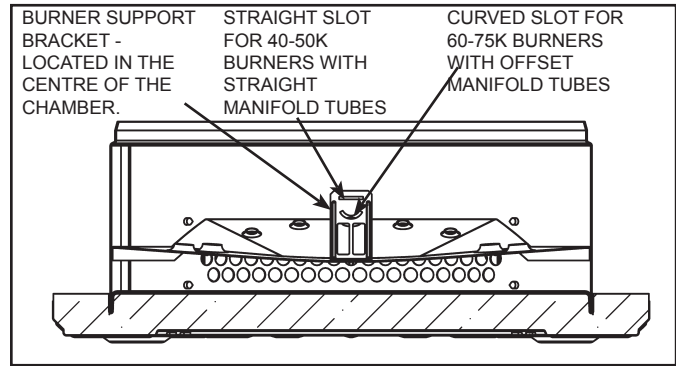

Figure 12. Manifold/Burner Assembly

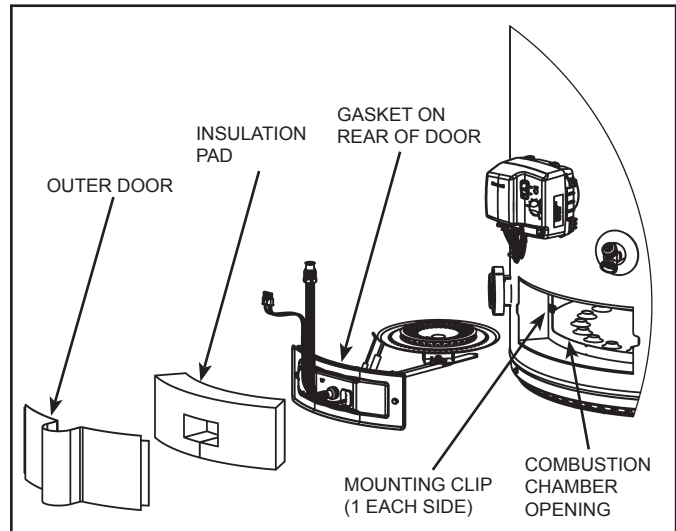
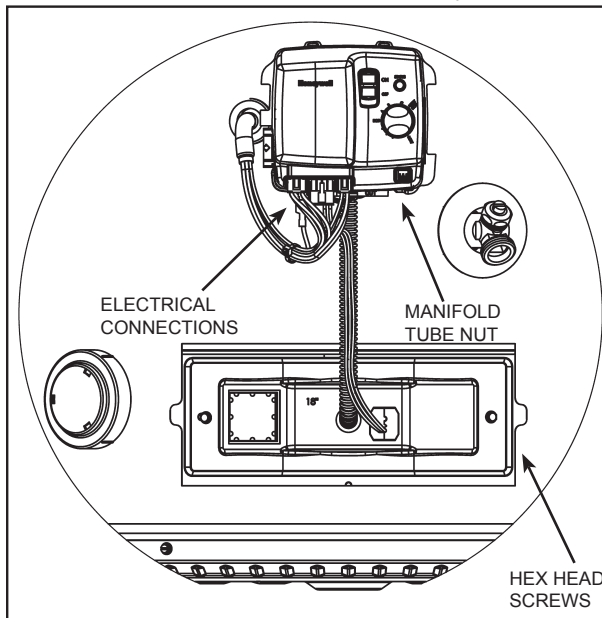

Figure 13. Burner Chamber Compartment Doors



**Note:** Outer door and insulation not shown for clarity.

Figure 11. Electrical Connections at the Bottom of the Gas Valve

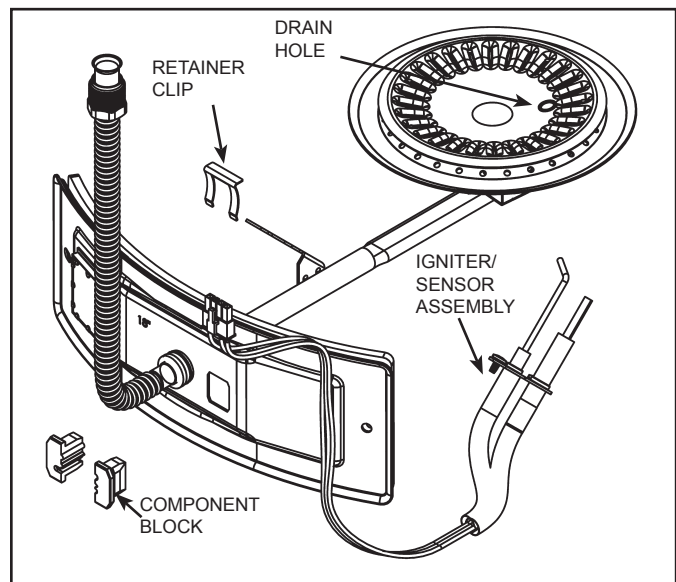

Figure 14. Burner and Igniter Sensor Assemblies

# BURNER AND ORIFICE REMOVAL/REPLACEMENT

## BURNER

**Important:** Use only factory authorized replacement parts. If you lack the necessary skills to properly perform the installation, you should not proceed, but get help from a qualified service technician.

### Tools Required

- 3/4" Open-End Wrench
- Phillips Head Screwdriver
- Ratchet with 1/4" socket or 1/4" nut-driver.

### REMOVING INNER DOOR/MANIFOLD/ BURNER ASSEMBLY

1. Set the gas control valve/thermostat to its lowest setting by turning the knob counter-clockwise to the VAC point. See *Figure 3* (page 6).
2. Turn gas control switch to the "OFF" position and turn "OFF" the gas supply to the unit. See *Figure 3* (page 6).
3. Disconnect the electrical power to the water heater from the wall outlet.
4. Remove the outer door from the unit.
5. Unplug all the electrical connections from the bottom of the gas control valve/thermostat. See *Figure 15* (page 14).
6. Using a 3/4" open end wrench remove the manifold tube from the gas control valve/thermostat (turning counter-clockwise for natural gas, clockwise for LP). Grasp the manifold tube and push down slightly to free the manifold tube from the gas control valve/thermostat. See *Figure 15* (page 14).
7. Remove the insulation pad on the inner door by cutting it if necessary. Keep the insulation in a safe place for reusing it later.
8. Use a 1/4" nut-driver or 1/4" socket & ratchet to loosen the 2 hex head screws on the inner door so the inner door/manifold/burner assembly can be removed. See *Figure 15* (page 14).
9. Remove inner door/manifold/burner assembly by grasping the manifold, rotating it to the left to clear the igniter and flame sensor and pulling back. Care should be taken when inner door and burner assembly passes through jacket opening that it does not damage any of the electrical wiring. See *Figure 17* (page 14).

### REMOVING BURNER

1. Burner may be hot. Wait until burner has cooled off. After noting the position of the condensation drain hole on the top of the burner, turn the inner door/manifold/burner assembly upside down. Using a Phillips head screwdriver, remove and retain the 2 screws attaching the burner to the manifold pipe. See *Figure 18* (page 8) and *Figure 19* (page 15).

### INSTALLING BURNER:

Care **MUST** be taken to ensure the burner is installed correctly on the inner door/manifold assembly. Position the new burner upside down with the orientation of the burner's condensation drain as shown in illustration. See *Figure 18* (page 8) and *Figure 19* (page 15).

1. Align the screw holes on the inner door/manifold assembly. Using the two screws removed in step 1 of Removing Burner, install the new burner to the inner door/ manifold assembly (rotate the assembly to visually check the top portion of the burner assembly and confirm the orientation of the condensation drain hole. See *Figure 18* (page 8) and the note that follows it.

### Caution Must Be Taken

Prior to installing the new inner door/manifold/burner assembly, look inside the burner chamber to fully understand the correct positioning of the burner assembly and burner manifold tab. It may be necessary to use a flashlight to ensure correct placement. Care must be taken so as to not damage any electrical wiring, or components as you are installing the new inner door/manifold/burner assembly. Extra caution should be taken to ensure that electrical wiring, fiberglass insulation or any other object is not between door gasket and combustion chamber shield.

**Note:** If the burner door gasket is worn or damaged it needs to be replaced. See *Figure 9* (page 10). See also *Replacing The Door Gasket*. (page 3).

### REINSTALLING INNER DOOR/ MANIFOLD/BURNER ASSEMBLY

1. Insert the manifold/burner assembly in the burner chamber compartment, making sure that the tip of burner manifold tab engages in the proper slot of the bracket. The tip end of the burner manifold **MUST** be placed in the slotted portion under the condensation pan to obtain proper installation. See *Figure 16* (page 14).

#### Important:

- The tip end of the burner manifold **MUST** be placed in the **upper** slotted portion for models with input rate of 40,000 to 50,000 Btu/hr to obtain proper installation.
  - The tip end of the burner manifold **MUST** be placed in the **lower** slotted portion for models with input rate of 60,000 to 75,000 Btu/hr to obtain proper installation.
2. After confirming no materials of any type are between door gasket and combustion chamber shield, align the screws on the inner door with the screw holes on the combustion chamber and tighten with 1/4" nut-driver or 1/4" socket & ratchet. See *Figure 15* (page 14).

After tightening the inner door screws, visually inspect area around door gasket and skirt for spaces or gaps. The door gasket **MUST** be sealed completely in order for the water heater to perform properly.

**DO NOT OPERATE THE WATER HEATER IF THE DOOR GASKET DOES NOT CREATE A SEAL BETWEEN MANIFOLD DOOR AND COMBUSTION CHAMBER.**

- Reconnect the manifold tube to the gas control valve/thermostat.

**Note:** Do Not apply any thread sealant at this connection). To prevent any cross threading the manifold tube should be started by hand (turn clockwise for natural gas, counter-clockwise for LP). Upon tightening with the fingers and confirming it has not been cross threaded, tighten nut with a 3/4" open end wrench. See *Figure 15* (page 14).

- Reconnect all the electrical connections to the bottom of the gas control valve/thermostat, gently pushing each connector up until it snaps into place. See *Figure 10* (page 10) and *Figure 15* (page 14).
- Reconnect the electrical power to the water heater in the wall outlet and turn the gas supply back "ON" to the gas control valve/thermostat.
- Restart the water heater by following the directions on the *Lighting and Operating Instructions* label located on the front of the water heater.
- As the burner is heating (view flames through view-port), test the manifold tube connection at the gas control valve/thermostat by brushing on an approved noncorrosive leak detection solution.

**Important:** Do Not splash any solution onto any electrical connections.

- Upon verifying proper operation of the water heater, replace the outer door.

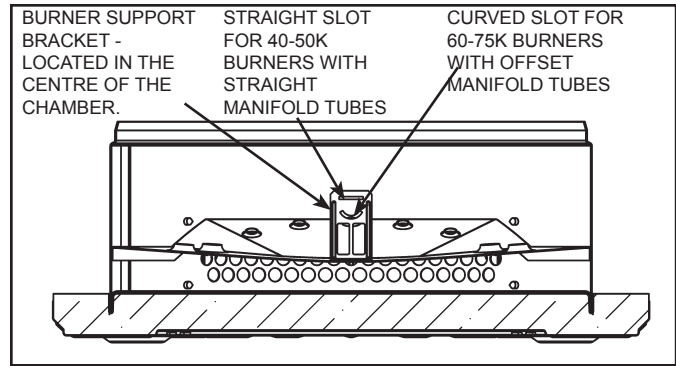

Figure 16. Manifold/Burner Assembly

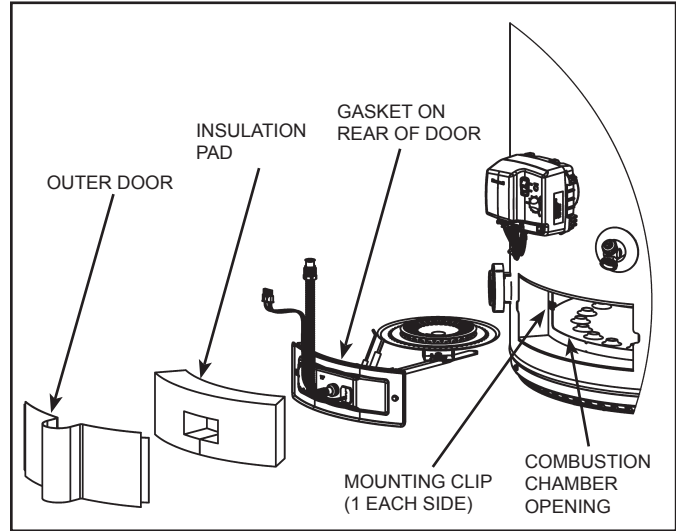

Figure 17. Burner Chamber Compartment Doors

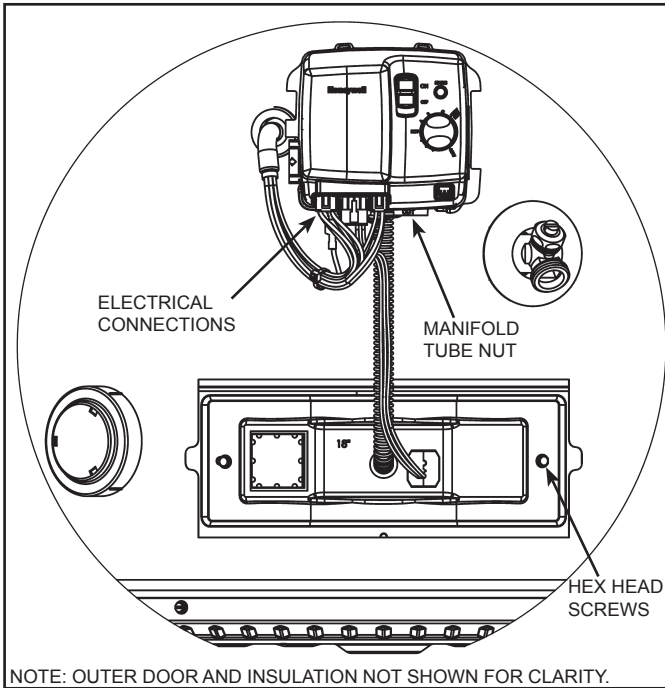

Figure 15. Electrical Connections at the Bottom of the Gas Valve

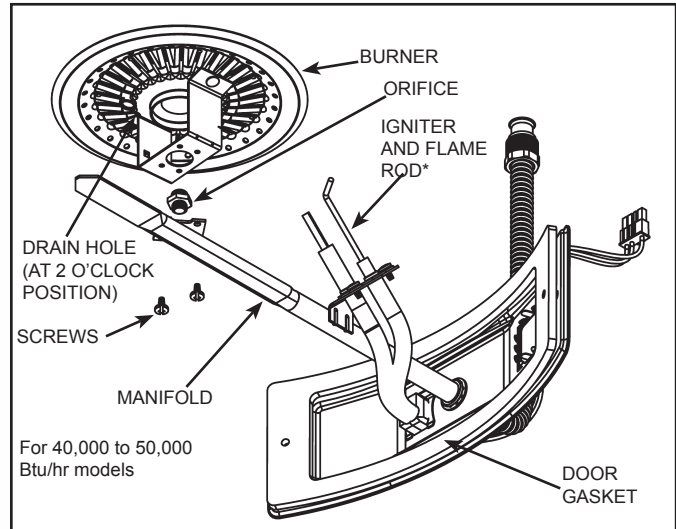

Figure 18. Burner/Igniter Assemblies for 40,000 to 50,000 Btu Models

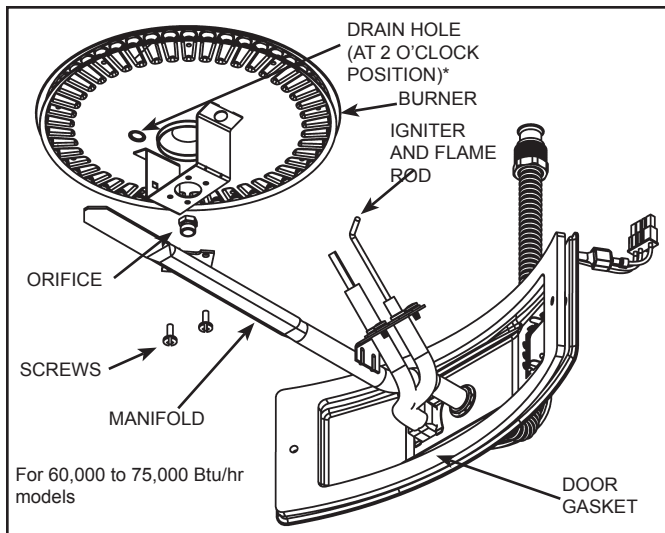

Figure 19. Burner and Igniter Assemblies for 60,000 to 75,000 Btu Models

**Note:** The drain hole must be at the 2 o'clock position, directly opposite the igniter and flame rod.

## BURNER ORIFICE

**Important:** Use only factory authorized replacement parts. If you lack the necessary skills to properly perform the installation, you should not proceed, but get help from a qualified service technician.

### Tools Required

- 3/4" Open-End Wrench
- Phillips Head Screwdriver
- Ratchet with 1/4" socket or 1/4" nut-driver
- Ratchet with 1/2" socket.

### REMOVING INNER DOOR/MANIFOLD/BURNER ASSEMBLY

1. Set the gas control valve/thermostat to its lowest setting by turning the knob counter-clockwise to the VAC point. See **Figure 3** (page 6).
2. Turn gas control switch to the "OFF" position and turn "OFF" the gas supply to the unit. See **Figure 3** (page 6).
3. Disconnect the electrical power to the water heater from the wall outlet.
4. Remove the outer door from the unit.
5. Unplug all the electrical connections from the bottom of the gas control valve/thermostat. See **Figure 15** (page 14).
6. Using a 3/4" open end wrench remove the manifold tube from the gas control valve/thermostat (turning counter-clockwise for natural gas, clockwise for LP). Grasp the manifold tube and push down slightly to free the manifold tube from the gas control valve/thermostat. See **Figure 15** (page 14).
7. Remove the insulation pad on the inner door by cutting it if necessary. Keep the insulation in a safe place for reusing it later.
8. Use a 1/4" nut-driver or 1/4" socket & ratchet to loosen the 2 hex head screws on the inner door so the inner door/manifold/burner assembly can be removed. See **Figure 15** (page 14).

9. Remove inner door/manifold/burner assembly by grasping the manifold, rotating it to the left to clear the igniter and flame sensor and pulling back. Care should be taken when inner door and burner assembly passes through jacket opening that it does not damage any of the electrical wiring. See **Figure 17** (page 14).

### REMOVING BURNER ORIFICE

1. Burner may be hot. Wait until burner has cooled off. After noting the position of the condensation drain hole on the top of the burner, turn the inner door/manifold/burner assembly upside-down. Using a Phillips head screwdriver, remove and retain the 2 screws attaching the burner to the manifold pipe. See **Figure 18** (page 8) and **Figure 19** (page 15).
2. Using a ratchet with 1/2" socket, remove the burner's old orifice.

**Note:** The burner orifices have different threads dependent upon the gas type. Orifices for natural gas have right-hand threads, orifices for LP have left-hand threads. See **Figure 18** (page 8) and **Figure 19** (page 15).

### INSTALLING BURNER ORIFICE

1. Using a ratchet with 1/2" socket, install the new burner orifice.
 

**Note:** The burner orifices have different threads dependent upon the gas type. right-handed threads for natural gas (turn clockwise to install) and left-handed threads for propane gas (turn counter-clockwise to install). See **Figure 18** (page 8) and **Figure 19** (page 15).

**Note:** Determine whether the orifice is tall or short and DO NOT replace them with each other.
2. Care MUST be taken to ensure the burner is installed correctly on the inner door/manifold assembly. Position the new burner upside down with the orientation of the burner's condensation drain as noted in **Removing Burner Orifice** step 1.

- Align the screw holes on the inner door/manifold assembly. Using the two screws removed in step 1 above, install the new burner to the inner door/manifold assembly (rotate the assembly to visually check the top portion of the burner assembly and confirm the orientation of the condensation drain hole as shown in the illustration. See **Figure 18** (page 8) and **Figure 19** (page 15).

### Caution Must Be Taken

Prior to installing the new inner door/manifold/burner assembly, look inside the burner chamber to fully understand the correct positioning of the burner assembly and burner manifold tab. It may be necessary to use a flashlight to ensure correct placement. Care must be taken so as to not damage any electrical wiring or components as you are installing the new inner door/manifold/burner assembly.

Extra caution should be taken to ensure that electrical wiring, fiberglass insulation or any other object is not between door gasket and combustion chamber shield.

**Note:** If the burner door gasket is worn or damaged it needs to be replaced. See **Figure 9** (page 10). See also **Replacing The Door Gasket**. (page 3).

### REINSTALLING INNER DOOR/ MANIFOLD/BURNER ASSEMBLY

- Insert the manifold/burner assembly in the burner chamber compartment, making sure that the tip of burner manifold tab engages in the proper slot of the bracket. See **Figure 16** (page 14).

#### Important:

- The tip end of the burner manifold MUST be placed in the **upper** slotted portion for models with input rate of 40,000 to 50,000 Btu/hr to obtain proper installation.
- The tip end of the burner manifold MUST be placed in the **lower** slotted portion for models with input rate of 60,000 to 75,000 Btu/hr to obtain proper installation.

- After confirming no materials of any type are between door gasket and combustion chamber shield, align the screws on the inner door with the screw holes on the combustion chamber and tighten with 1/4" nut-driver or 1/4" socket & ratchet. See **Figure 15** (page 14).

After tightening the inner door screws, visually inspect area around door gasket and skirt for spaces or gaps. The door gasket MUST be sealed completely in order for the water heater to perform properly.

**DO NOT OPERATE THE WATER HEATER IF THE DOOR GASKET DOES NOT CREATE A SEAL BETWEEN MANIFOLD DOOR AND COMBUSTION CHAMBER.**

- Reconnect the manifold tube to the gas control valve/thermostat.

**Note:** **Do Not** apply any thread sealant at this connection). To prevent any cross threading the manifold tube should be started by hand. (Turn clockwise for natural gas, counter-clockwise for LP.) Upon tightening with the fingers and confirming it has not been cross threaded, tighten nut with an 3/4" open end wrench. See **Figure 15** (page 14).

- Reconnect all the electrical connections to the bottom of the gas control valve/thermostat, gently pushing each connector up until it snaps into place. See **Figure 10** and **Figure 15**).
- Reconnect the electrical power to the water heater in the wall outlet and turn the gas supply back "ON" to the gas control valve/thermostat.
- Restart the water heater by following the directions on the **Lighting and Operating Instructions** label located on the front of the water heater.
- As the burner is heating (view flames through view-port), test the manifold tube connection at the gas control valve/thermostat by brushing on an approved noncorrosive leak detection solution.

**Important:** **Do Not** splash any solution onto any electrical connections.

- Upon verifying proper operation of the water heater, replace the outer door.

## DOOR GASKET REPLACEMENT

### DOOR GASKET

**Important:** Use only factory authorized replacement parts. If you lack the necessary skills to properly perform the installation, you should not proceed, but get help from a qualified service technician.

#### Tools Required

- 3/4" Open-End Wrench
- 3/4" Scraper
- Ratchet with 1/4" socket or 1/4" nut-driver
- Flashlight

### REMOVING INNER DOOR/ MANIFOLD/ BURNER ASSEMBLY

- Set the gas control valve/thermostat to its lowest setting by turning the knob counter-clockwise to the VAC point. See **Figure 3** (page 6).
- Turn gas control switch to the "OFF" position and turn "OFF" the gas supply to the unit. See **Figure 3** (page 6).
- Disconnect the electrical power to the water heater from the wall outlet.
- Remove the outer door from the unit.
- Unplug all the electrical connections from the bottom of the gas control valve/thermostat. See **Figure 7** (page 8).

6. Using a 3/4" open end wrench remove the manifold tube from the gas control valve/thermostat (turning counter-clockwise for natural gas, clockwise for LP). Grasp the manifold tube and push down slightly to free the manifold tube from the gas control valve/thermostat. See *Figure 7* (page 9).
  7. Remove the insulation pad on the inner door by cutting it if necessary. Keep the insulation in a safe place for reusing it later.
  8. Use a 1/4" nut-driver or 1/4" socket & ratchet to loosen the 2 hex head screws on the inner door so the inner door/manifold/burner assembly can be removed. See *Figure 7* (page 9).
  9. Remove inner door/manifold/burner assembly by grasping the manifold and pull back slowly. Rotating it to the left to clear the igniter and flame sensor. Care should be taken when inner door and burner assembly passes through jacket opening that it does not damage any of the electrical wiring. See *Figure 9* (page 10).
2. After confirming no materials of any type are between door gasket and combustion chamber shield, align the screws on the inner door with the screw holes on the combustion chamber and tighten with 1/4" nut-driver or 1/4" socket & ratchet. See *Figure 7* (page 9).  
After tightening the inner door screws, visually inspect area around door gasket and skirt for spaces or gaps. The door gasket **MUST** be sealed completely in order for the water heater to perform properly.  
**DO NOT OPERATE THE WATER HEATER IF THE DOOR GASKET DOES NOT CREATE A SEAL BETWEEN MANIFOLD DOOR AND COMBUSTION CHAMBER.**

### REMOVING THE DOOR GASKET

1. Locate the gasket that is on the rear of the burner door assembly. See *Figure 17* (page 14), *Figure 18* (page 8), and *Figure 19* (page 15).
2. Pull off this gasket and using the 3/4" scraper, scrape away and gasket stuck to the door.
3. Using the 3/4" scraper, clean around the combustion chamber opening to ensure no old gasket material is stuck on the combustion chamber. See *Figure 17* (page 14). Use the flashlight to clearly illuminate this area. Take care not to damage the mounting clips located on each side of the opening.

### REPLACING THE DOOR GASKET.

1. Remove the paper cover on the new door gasket. This will expose the gasket adhesive.
2. Position the gasket on the freshly cleaned door surface so that the adhesive firmly holds the gasket to the door.
3. Smooth the gasket to avoid creases.

### RE-INSTALLING INNER DOOR/ MANIFOLD/BURNER ASSEMBLY

1. Insert the manifold/burner assembly in the burner chamber compartment, making sure that the tip of burner manifold tab engages in the proper slot of the bracket. See *Figure 8* (page 10).

#### Important:

- The tip end of the burner manifold **MUST** be placed in the **upper** slotted portion for models with input rate of 40,000 to 50,000 Btu/hr to obtain proper installation.
- The tip end of the burner manifold **MUST** be placed in the **lower** slotted portion for models with input rate of 60,000 to 75,000 Btu/hr to obtain proper installation.

3. Reconnect the manifold tube to the gas control valve/thermostat

**Note:** Do Not apply any thread sealant at this connection). To prevent any cross threading the manifold tube should be started by hand (turn clockwise for natural gas, counter-clockwise for LP). Upon tightening with the fingers and confirming it has not been cross threaded, tighten nut with a 3/4" open end wrench. See *Figure 7* (page 9).

4. Reinstall the insulation pad which was removed in step 7 above.
5. Reconnect all the electrical connections to the bottom of the gas control valve/thermostat, gently pushing each connector up until it snaps into place. See *Figure 10* (page 10) and *Figure 15* (page 14).
6. Reconnect the electrical power to the water heater in the wall outlet and turn the main gas supply back "ON" to the gas control valve/thermostat.
7. Restart the water heater by following the directions on the **Lighting and Operating Instructions** label located on the front of the water heater. Test gas connections by brushing on an approved non-corrosive leak detection solution.

**Note:** Do not splash the solution on control. If a leak is detected, shut the water heater down by following the directions on the **Lighting and Operating Instructions**. Repair the leak(s) and repeat this step.

8. Upon verifying proper operation of the water heater, replace the insulation and outer door.

# CONTROL MODULE REMOVAL/REPLACEMENT

## ELECTRONIC CONTROL MODULE

**Important:** Do not remove the entire gas control assembly from the water heater.

**Important:** Use only factory authorized replacement parts. If you lack the necessary skills to properly perform the installation, you should not proceed, but get help from a qualified service technician.

### Tools required

- T15 Torx screwdriver
- Flat-blade screwdriver

## REMOVING ELECTRONIC CONTROL MODULE

1. Set the gas control valve/thermostat to its lowest setting by turning the knob counter-clockwise to the VAC point. See *Figure 20* (page 18).
2. Turn gas control switch to the "OFF" position and turn off the gas supply to the unit. See *Figure 20* (page 18).
3. Disconnect the electrical power to the water heater from the wall outlet.
4. Remove the front Torx screw at the bottom of the gas control valve/thermostat as illustrated in *Figure 21* (page 18).
5. Use a flat-blade screwdriver to release the two tabs at the top of the gas control valve/thermostat and lift the electronic control straight up. See *Figure 22* (page 19) and *Figure 23* (page 19).
6. Disconnect the temperature sensor cable.

**Note:** When removing the control module from the gas control assembly, disengage the pins on the valve module without causing damage.

7. Re-assemble in the reverse order.

**Note:** During re-assembly, align the pins on the valve module to their proper location in the control module without causing damage.

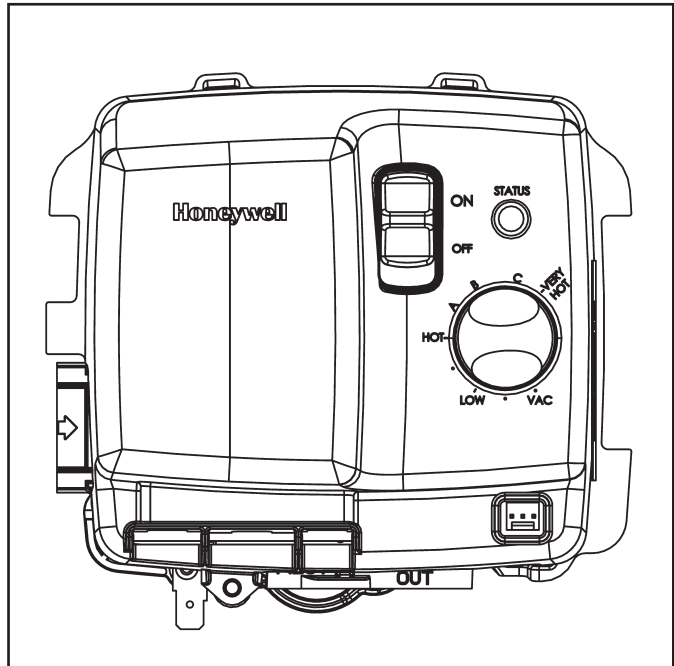

Figure 20. Temperature Adjusting Dial



Figure 21. Gas Valve Side View Showing Torx Screw

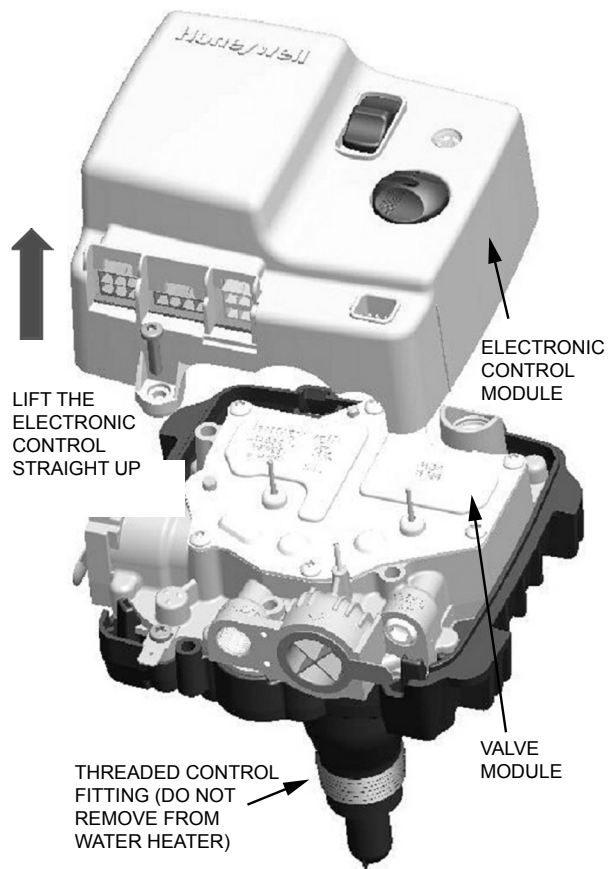

Figure 22. Gas Valve Top View - Exploded

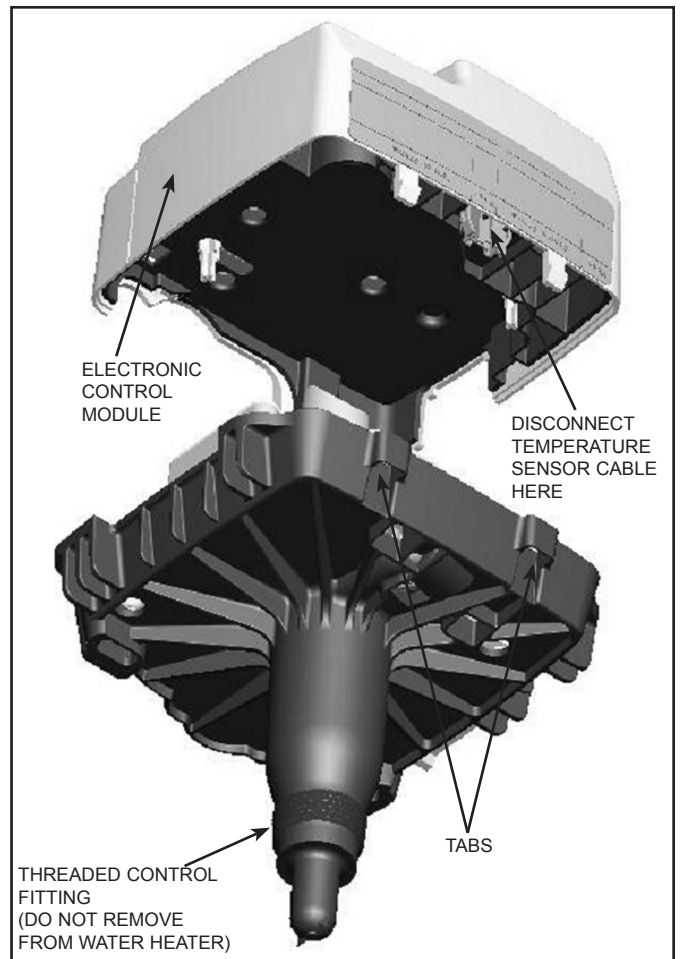

Figure 23. Gas Valve Bottom View - Exploded

# VALVE MODULE REMOVAL/REPLACEMENT

## VALVE MODULE

**Important:** Do not remove the entire gas control assembly from the water heater.

**Important:** Use only factory authorized replacement parts. If you lack the necessary skills to properly perform the installation, you should not proceed, but get help from a qualified service technician.

### Tools Required

- T15 Torx screwdriver
- Flat-blade screwdriver

### REMOVING VALVE MODULE

1. Set the gas control valve/thermostat to its lowest setting by turning the knob counter-clockwise to the VAC point. See *Figure 20* (page 18).
2. Turn gas control switch to the "OFF" position and turn off the gas supply to the unit. See *Figure 20* (page 18).
3. Disconnect the electrical power to the water heater from the wall outlet.
4. Remove the Electronic Control Module as outlined in *Removing Electronic Control Module* (page 18).

**Note:** When removing the control module from the gas control assembly, disengage the pins on the valve module without causing damage.

5. Remove the screw and the ground tab with a Torx screwdriver. See *Figure 24*.
6. Insert a flat-blade screwdriver between the casting and the locking tabs at the bottom of the valve.

7. Carefully pry against the casting until it barely slides past the locking tab edge.
8. Repeat on the opposite side.
9. Replace the valve.

**Note:** When replacing the valve, do not apply pressure with the hand on the valve pins.

10. Re-assemble in the reverse order.

**Note:** During re-assembly, align the pins on the valve module to their proper location in the control module without causing damage.

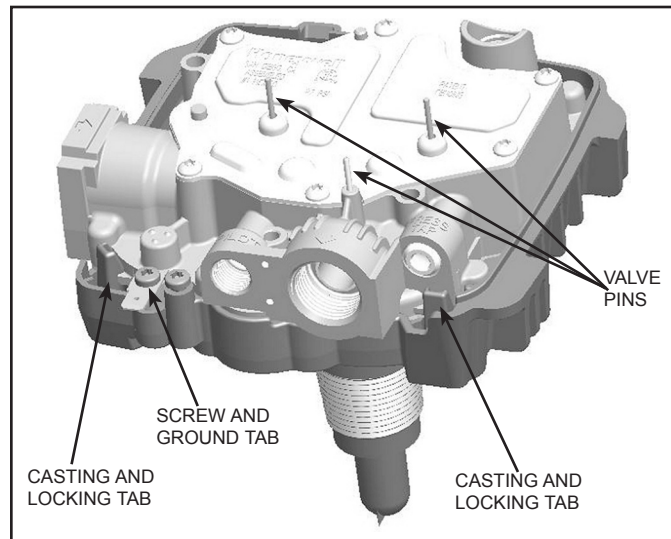

Figure 24. Gas Valve Showing Torx Screw and Ground Tab

# TEMPERATURE SENSOR AND CABLE REMOVAL/REPLACEMENT

## TEMPERATURE SENSOR AND CABLE

**Important:** Do not remove the entire gas control assembly from the water heater.

**Important:** Use only factory authorized replacement parts. If you lack the necessary skills to properly perform the installation, you should not proceed, but get help from a qualified service technician.

Tools required:

- T15 Torx screwdriver
- Flat-blade screwdriver

## REMOVING TEMPERATURE SENSOR AND CABLE

1. Set the gas control valve/thermostat to its lowest setting by turning the knob counter-clockwise to the VAC point. See *Figure 20* (page 18).
2. Turn gas control switch to the "OFF" position and turn off the gas supply to the unit. See *Figure 20* (page 18).
3. Disconnect the electrical power to the water heater from the wall outlet.
4. Remove the Electronic Control Module as outlined in *Removing Electronic Control Module* (page 18).

**Note:** When removing the control module from the gas control assembly, disengage the pins on the valve module without causing damage.

5. Remove the Valve Module as outlined in *Removing Valve Module* (page 20).
6. Use a screwdriver to pry under the sensor retainer finger to remove the temperature sensor and cable. See *Figure 25*.
7. Re-assemble in the reverse order.

**Note:** When replacing the valve, do not apply pressure with the hand on the valve pins.

**Note:** During re-assembly, align the pins on the valve module to their proper location in the control module without causing damage.

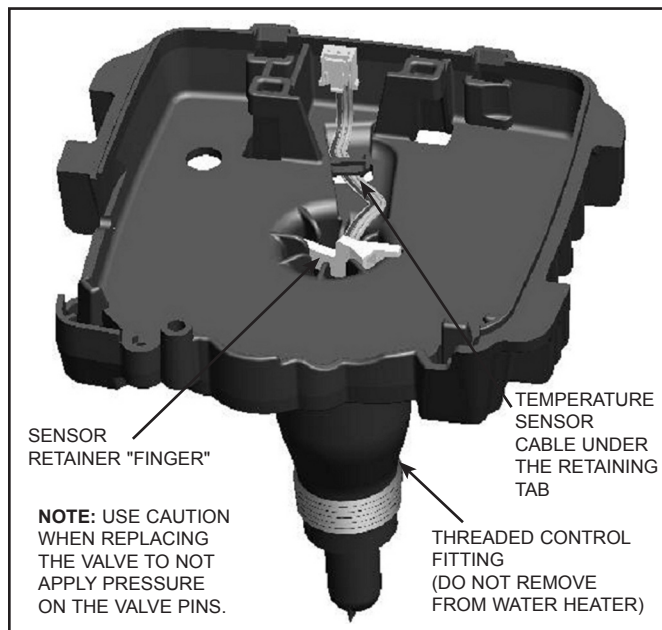

Figure 25. Temperature Sensor Retaining Finger

# GAS VALVE REMOVAL/REPLACEMENT

**Important:** Use only factory authorized replacement parts. If you lack the necessary skills to properly perform the installation, you should not proceed, but get help from a qualified service technician.

## Tools Required

- 3/4" Open-End Wrench
- Short length of 1/2" threaded pipe
- Pipe Wrench

## REMOVING GAS CONTROL VALVE

1. Set the gas control valve/thermostat to its lowest setting by turning the knob counter-clockwise to the VAC point. See **Figure 3** (page 6).
2. Turn gas control switch to the "OFF" position and turn off the gas supply to the unit. See **Figure 3** (page 6).
3. Disconnect the electrical power to the water heater from the wall outlet.
4. Release water pressure by opening a nearby hot water faucet, let run until water is cool to touch. Turn off water supply to the water heater.
5. Remove the outer door from the unit.
6. Connect a drain hose to the drain valve and run it to an adequate drain or to the exterior of the building. Open the water heater drain valve and allow the water to drain from the tank.
7. Unplug all the electrical connections from the bottom of the gas control valve/thermostat. See **Figure 26** (page 23).
8. Using a 3/4" open end wrench remove the manifold tube from the gas control valve/thermostat (turning counter-clockwise for natural gas, clockwise for LP). Grasp the manifold tube and push down slightly to free the manifold tube from the gas control valve/thermostat. See **Figure 26** (page 23).
9. Ensuring that the gas supply line is turned off, disconnect the gas piping at the ground joint union, then remove the gas piping from the gas control valve/thermostat.
10. Remove any other fittings that may be installed on the threaded pipe to the gas control valve/thermostat.
11. After ensuring the water heater is completely drained, thread a short length of 1/2" threaded pipe into the inlet connection of the gas control valve/thermostat and use it to turn the gas control valve/thermostat counter-clockwise to remove. See **Figure 27** (page 23). Do not use any type of wrench on the valve body as it may cause damage to the gas control valve/thermostat assembly.

## INSTALLING GAS CONTROL VALVE

1. Do not apply any sealant tape to the gas control/thermostat threads that screw into the tank. The threads have a pre-applied white sealing material.
2. Thread a short length of 1/2" threaded pipe into the inlet connection of the new gas control valve/thermostat and use it to turn the gas control valve/thermostat clockwise to tighten into place.

**Note:** Do Not over tighten or damage may result, but it needs to be water tight.  
See **Figure 27** (page 23).

3. Remove the 1/2" threaded pipe from the gas control valve/thermostat.
4. Reconnect the gas piping to the gas control valve/thermostat, use Teflon® tape or an approved pipe sealant on threads of the piping.
5. Close the drain valve and turn on the cold water supply line filling the tank completely with water. Purge the water lines of any excess air by opening a hot water faucet allowing the water to flow for a minimum of 3 minutes, allowing the tank to fill completely.
6. Reconnect the manifold tube to the gas control valve/thermostat

**Note:** Do Not apply any thread sealant at this connection). To prevent any cross threading the manifold tube should be started by hand (turn clockwise for natural gas, counter-clockwise for LP). Upon tightening with the fingers and confirming it has not been cross threaded, tighten nut with an 3/4" open end wrench. See **Figure 26** (page 23).

7. Reconnect all the electrical connections to the bottom of the gas control valve/thermostat, gently pushing each connector up snapping into place. See **Figure 10** (page 10) and **Figure 26** (page 23).
8. Turn on the gas supply to the unit and test the gas supply line and union connections by brushing on an approved noncorrosive leak detection solution.

**Note:** Do not splash the solution on control. If a leak is detected, shut the water heater down by following the directions on the **Lighting and Operating Instructions**. Repair the leak(s) and repeat leak test).

9. Reconnect the electrical power to the water heater in the wall outlet and turn the gas supply back on to the gas control valve/thermostat.
10. Restart the water heater by following the directions on the label located on the front of the water heater.
11. As the burner is heating (view flames through view-port), test the manifold tube connection at the gas control valve/thermostat by brushing on an approved noncorrosive leak detection solution.

**Important:** Do Not splash any solution onto any electrical connections.

12. Upon verifying proper operation of the water heater, replace the outer door.

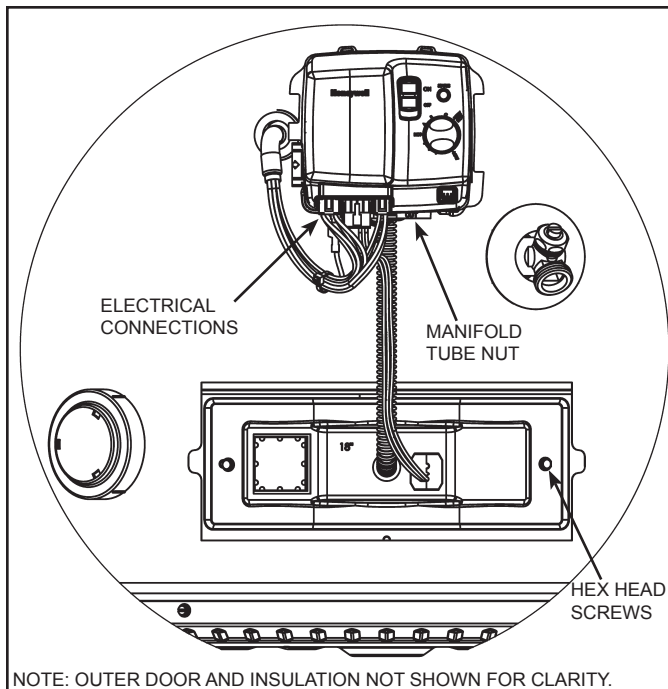

Figure 26. Electrical Connections at the Bottom of the Gas Valve

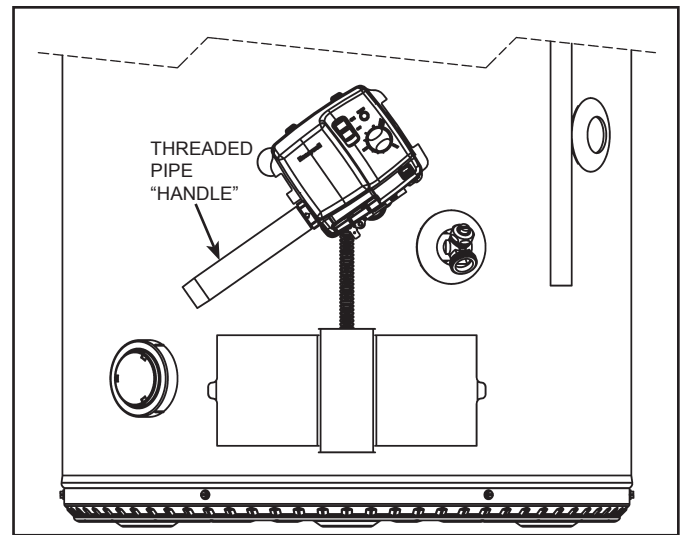

Figure 27. Using a Threaded Pipe as a Handle to Turn the Gas Control Valve/Thermostat

## BLOWER REMOVAL/REPLACEMENT

### BLOWER

**Important:** Use only factory authorized replacement parts. If you lack the necessary skills to properly perform the installation, you should not proceed, but get help from a qualified service technician.

Tools required:

- Ratchet with 5/16" socket or 5/16" nut-driver
- Ratchet with 1/4" socket or 1/4" nut-driver

### REMOVING BLOWER

1. Set the gas control valve/thermostat to its lowest setting by turning the knob counter-clockwise to the VAC point. See *Figure 3* (page 6).
2. Turn gas control switch to the "OFF" position and turn "OFF" the gas supply to the unit. See *Figure 3* (page 6)
3. Disconnect the electrical power to the water heater from the wall outlet.
4. Use a 5/16" nut-driver to loosen the screw on the upper gear clamp of the rubber coupling adapter connecting the venting to the blower. Slowly pull the vent from the adapter. See *Figure 28* (page 24).

**Note:** The rubber coupling adapter will be different based on the venting size (2" or 3" vent pipe).

5. Use a 1/4" nut-driver or 1/4" socket & ratchet to loosen the screw on the junction box. Remove and retain the screw and junction box cover. Disconnect the power and ground connectors. See *Figure 28* (page 24).

6. Use a 1/4" nut-driver or 1/4" socket & ratchet to loosen, remove and retain the 6 hex head screws so the blower assembly can be removed. Remove the blower while carefully passing the power and ground connectors through the junction box opening. See *Figure 28* (page 24).

**Important:** When removing the blower, care must be taken to pass the power and ground connectors through the junction box opening so the wires and blower do not get damaged.

### INSTALLING BLOWER

1. Pass the power and ground connectors through the junction box opening and place the blower on top of the water heater.
2. Reconnect the power connector and the ground connector. Reinstall the junction box cover and screw removed in step 5 above. Tighten with 1/4" nut-driver or 1/4" socket & ratchet.
3. Align the screw holes on the blower assembly with those on the top of the heater. Using the six screws removed in step 6 above, install the blower assembly and tighten with 1/4" nut-driver or 1/4" socket & ratchet. See *Figure 28* (page 24).
4. Reinstall the vent by pushing it into the adapter. After confirming the vent is properly seated in the adapt, use a 5/16" nut-driver to tighten the screw on the gear clamp of the adapter connecting the venting to the blower

**Important:** This connection must be properly sealed to prevent the leakage of the products of combustion into the living area.

5. Reconnect the electrical power to the water heater in the wall outlet and turn the gas supply back "ON" to the gas control valve/thermostat.

- Restart the water heater by following the directions on the label located on the front of the water heater.

**Note:** This power vent heater will accept a 2" or 3" rubber outlet coupling, depending on the size of the water heater. This coupling, mounted in the vertical position, accepts the vent piping and is attached as shown in **Figure 28**. See the **Manual** to determine vent pipe sizing for your application. The blower assembly may be rotated 90 degrees clockwise or counter-clockwise to allow horizontal venting in areas having restricted space above the water heater. See **Rotating The Blower** (page 24).

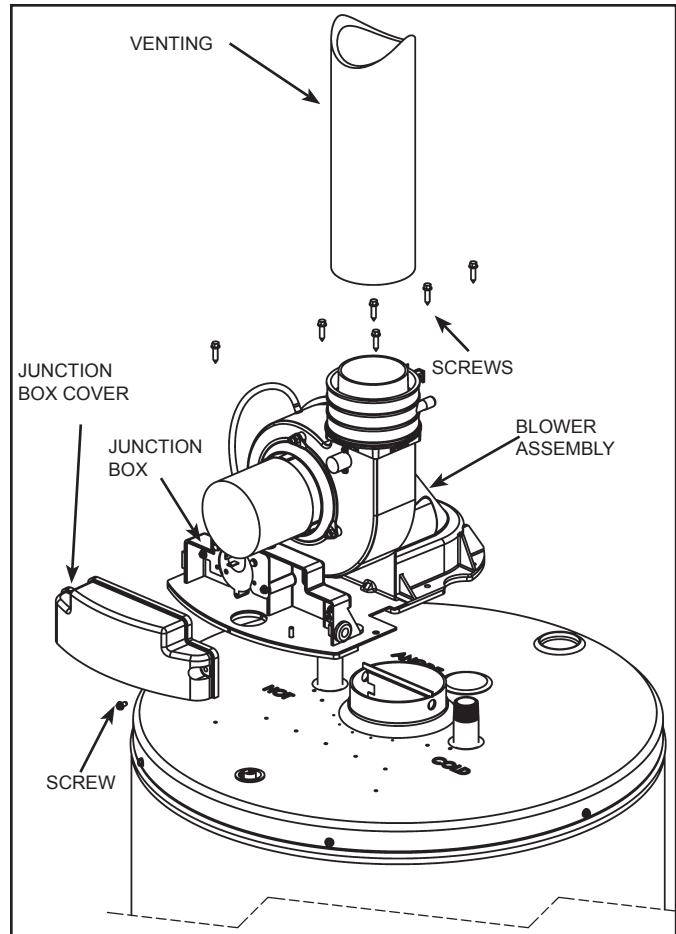

Figure 28. Removing the Blower

## ROTATING THE BLOWER

### BLOWER EXHAUST DIRECTION

**Important:** Use only factory authorized replacement parts. If you lack the necessary skills to properly perform the installation, you should not proceed, but get help from a qualified service technician.

#### Tools required:

- Ratchet with 11/32" socket or 11/32" nut-driver

The blower assembly may be rotated 90 degree clockwise or counterclockwise to allow horizontal venting in areas having restricted space above the water heater. To rotate the blower outlet, remove the four nuts with 11/32" nut driver, securing the flue collector to the blower housing. See **Figure 29**

Pull the blower assembly forward to free it from the mounting studs. Rotate the blower housing clockwise or counter-clockwise and align the four holes and screws together. Reattach the blower housing to the flue collector.

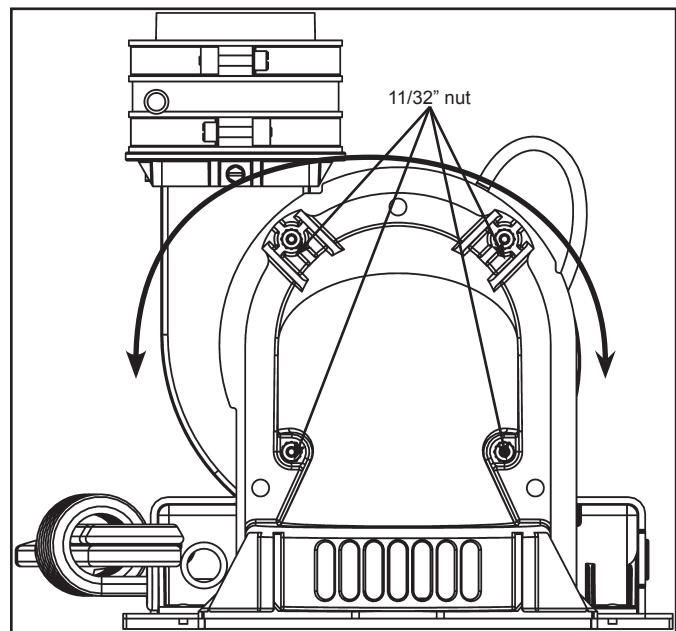

Figure 29. Rotating the Blower Outlet

This power vent heater can accept 2" or 3" rubber outlet coupling, depending on the capacity of the water heater. This coupling, mounted in the vertical position, accepts the vent piping and is attached as shown in **Figure 28**.

# PRESSURE SWITCH REMOVAL/REPLACEMENT

## PRESSURE SWITCH

**Important:** Use only factory authorized replacement parts. If you lack the necessary skills to properly perform the installation, you should not proceed, but get help from a qualified service technician.

### Tools Required

- Phillips Head Screwdriver
- Ratchet with 1/4" socket or 1/4" nut-driver

## REMOVING PRESSURE SWITCH

1. Set the gas control valve/thermostat to its lowest setting by turning the knob counter-clockwise to the VAC point. See *Figure 3* (page 6).
2. Turn gas control switch to the "OFF" position and turn "OFF" the gas supply to the unit. See *Figure 3* (page 6).
3. Disconnect the electrical power to the water heater from the wall outlet.
4. Use a 1/4" nut-driver or 1/4" socket & ratchet to loosen the screw on the junction box. Remove and retain the screw and junction box cover. See *Figure 3* (page 6).
5. Remove the air pressure tubing from the air pressure switch by pulling upward on the tubing at the connection to the air pressure switch.
6. After noting the position of each electrical flag terminals, remove the two (2) electrical flag terminals from the switch by pulling outward and off the switch.
7. Using a hex head screwdriver, remove and retain the 2 screws securing the bracket to the junction box. See *Figure 30*.
8. Using a hex head screwdriver, remove and retain the 2 screws securing the pressure switch to the bracket. See *Figure 30*.

## INSTALLING PRESSURE SWITCH

1. Using a hex head screwdriver, secure the new pressure switch to the bracket with the screws removed in step 8 above. Care should be taken to ensure the proper orientation of the bracket and pressure switch. See *Figure 30* (page 25).
2. Using a hex head hex screwdriver, secure the bracket to the junction box with the screws removed in step 7 above. See *Figure 30* (page 25).
3. Reattach the two (2) electrical flag terminals by pushing the flag terminals onto the switch. Care MUST be taken to ensure that each of the electrical flag terminals is in its original position.
4. Reattach the air pressure tubing to the air pressure switch by pushing the tubing onto the connector until the end of the tubing reaches the shoulder of the connector.
5. Replace the blower's junction box door by reusing the screw removed in step 4 above.
6. Reconnect the electrical power to the water heater in the wall outlet and turn the gas supply back "ON" to the gas control valve/thermostat.
7. Restart the water heater by following the directions on the label located on the front of the water heater.

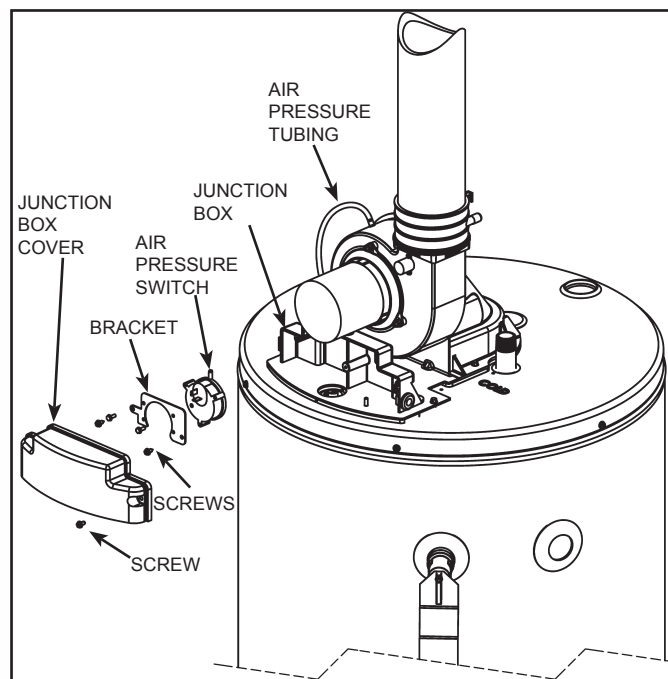

Figure 30. Removing the Pressure Switch

## FV SENSOR

### FLAMMABLE VAPOR SENSOR

When using a gas fired water heater there is a risk of flammable vapors entering the combustion chamber, being ignited by the burner flame and causing a flashback. In order to detect such flammable vapors before they enter the combustion chamber, this water heater is equipped with a flammable vapor sensor (FVS). It is a chemical-absorption based sensor that is connected to the gas control/thermostat. See **Figure 31**. When exposed to flammable vapors it will trigger the control to stop the flow of gas and enter the FVS lockout state. While in the FVS lockout state the LED on the control will flash the gas lockout code. See **Gas Control Led Status Codes** (page 36) for an explanation of the codes applicable to the control installed on your water heater. If an FVS lockout occurs, check around the water heater for sources of chemical contamination such as flammable vapors including gas vapors, solvents, paint and thinners as well as sources of water and detergents.

**Note:** Resetting the heater will reset the FVIR circuit if all sources of contamination have been removed and the sensor clears. If all sources of contamination have been removed and the system will not reset, the sensor will need to be replaced.

If there is a problem with the wiring of the flammable vapor sensor or the flammable vapor interface the LED will flash the failure status code. See **Troubleshooting Chart** (page 34).

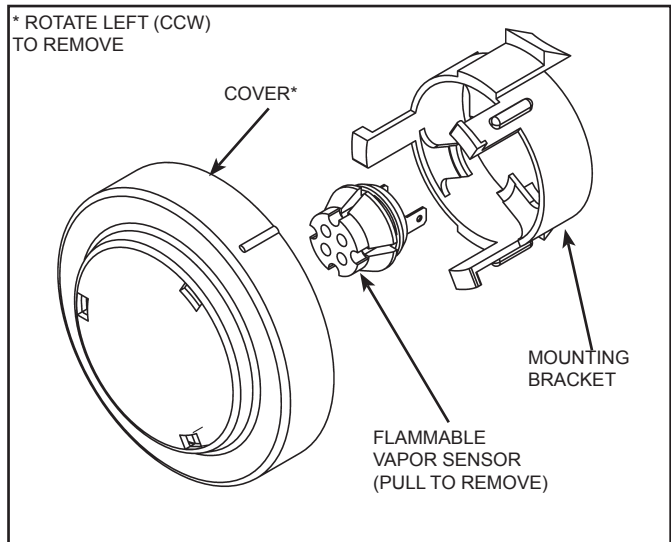

Figure 31. Flammable Vapor Sensor

## CLEANING THE COMBUSTION CHAMBER

1. Follow procedure outlined in **Removing Inner Door/Manifold/Burner Assembly** (page 9).
2. Use a vacuum cleaner/shop vac to remove all loose debris in the combustion chamber.
3. Reassemble following the procedure under **Re-installing Inner Door/Manifold/Burner Assembly** (page 9).

## CLEANING THE BLOWER

### BLOWER

In dusty and contaminated air conditions, the interior of the blower and the blower wheel may require periodic cleaning. This is often indicated by nuisance failures of the air pressure switch or the high limit temperature control. A collection of dust or debris on the rear blower air intakes can also indicate reduced blower capacity. To clean the inside of the blower assembly and the blower wheel requires the removal of the blower/motor from the mounting plate located on the top of the heater. Tools required include an 11/32" nut driver, small (1") paintbrush, toothbrush and vacuum cleaner.

1. Set the gas control valve/thermostat to its lowest setting by turning the knob counter-clockwise to the VAC point. See **Figure 3** (page 6).
2. Turn gas control switch to the "OFF" position and turn "OFF" the gas supply to the unit. See **Figure 3** (page 6).
3. Disconnect the electrical power to the water heater from the wall outlet.
4. Disconnect the vent piping from the top of the blower. Loosen the lower gear clamp that holds the rubber coupling to the blower.
5. Remove and retain the (4) 11/32" nuts located on the back of the blower with the nut-driver. See **Figure 32**.
6. Holding the blower motor and the blower housing, pull the assembly forward to disengage it from the mounting plate. The blower will still be connected to the junction box so exercise care not to stress the wiring.
7. Accessing the blower wheel through the outlet, use the paint brush to brush off the outer edge of the blower wheel to dislodge the dirt stuck on the blades and the inside of the housing. Rotate the wheel until all blades are clear.  
**Note:** The wheel is a balanced component. Do not bend, dent or distort the blades as this can upset the wheel balance and affect the blower operation. Vacuum out the loosened dirt.
8. Accessing the inside of the blower wheel through the rear of the housing, gently brush off the inside of the blades using the toothbrush. Again, take care not to distort the blades. Rotate the wheel until all blades are cleaned and vacuum the debris.
9. Inspect the flue collector hood (still attached to the heater) and vacuum out the dust and debris that may have accumulated.
10. With all parts cleaned and the blower wheel turning freely, reinstall the blower to the mounting plate aligning the (4) studs and pushing tight against the mounting plate.
11. Reinstall the (4) 11/32" nuts and tighten securely. All (4) nuts must be in place and secure to safely operate the blower.
12. Reattach the vent piping and coupling to the top of the blower, tighten the bottom gear clamp and ensure the piping is secure.

13. With all components clean and secure, reconnect the electrical power to the heater.
14. Reset the thermostat to the desired temperature setting and turn the gas control switch back to the "ON" position.

**Note:** If the water in the heater is hot, the unit will wait to operate until there is a need for more hot water.

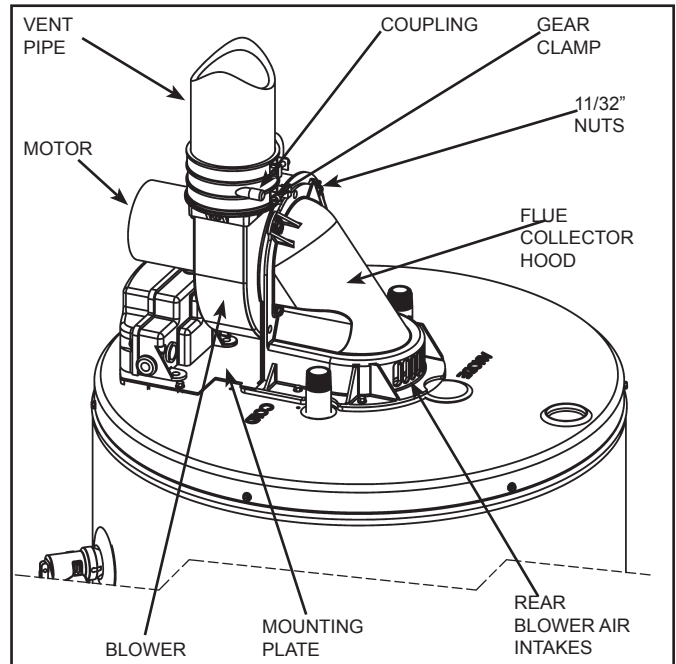

Figure 32. DIP Tube (Inlet Piping)

## TECHNICAL BULLETINS

| WATER HAMMER |  |
|--------------|--|
| GENERAL      | Water hammer is the destructive force, pounding noise and vibration in a piping system when water flowing through a pipeline is stopped abruptly. When water hammer occurs, a high intensity pressure wave travels back through the piping system until it reaches a point of some relief. The shock wave will then surge back and forth between the point of relief and the point of stoppage until the destructive energy is dissipated in the piping system. The violent action accounts for “banging”, “thumping”, and/or intense vibration in the pipe line. Although noise is generally associated with the occurrence of water hammer, it can occur without audible sound or noise. Quick closure of valves always causes some degree of shock with or without noise. The common cause of water hammer is single lever faucets (sinks/lavatories) or automatic solenoid valves (dishwashers, washing machines, etc.). The speed of the valve closure time is directly related to the intensity of the surge pressure. |
| EFFECTS      | <p>The damage from water hammer can manifest itself in a number of ways. The most common are:</p> <ul style="list-style-type: none"> <li>• Expanded Tank Shell - This can be demonstrated by measuring the circumference at various locations along the shell. Pressures in excess of the maximum design working pressure can cause permanent deformation of the shell.</li> </ul> <p><b>Note:</b> The continuous expansion of the tank shell may cause the tank to rupture at a welded seam.</p> <ul style="list-style-type: none"> <li>• Collapsed Flue Tube - This will choke off the ability to vent the products of combustion causing the flame and/or combustion to spill out from the combustion chamber. Often this will occur where thinning of the flue tube walls has occurred due to contamination of the combustion air or because of excessive condensation.</li> <li>• Inverted or Deformed Tank Heads - Often this accompanies collapsed flues, but one or both heads can be deformed.</li> </ul>           |
| THE FIX      | The only effective means of control is to install water hammer arrestors. These devices have diaphragms which separate an air chamber from the water in the piping system. As the shock wave reaches this device, the air chamber absorbs the shock. Arrestors should be located as close as possible to the source of the shock wave.   |
| NOTES        | Since water hammer exposes the equipment to pressures in excess of its design limits, failures caused by water hammer are not eligible for warranty consideration.   |

| MINERAL BUILD-UP |  |
|------------------|--|
| SYMPTOMS         | <ul style="list-style-type: none"> <li>• Rumbling</li> <li>• Crackling</li> <li>• Popping</li> </ul>   |
| CAUSE            | With the increase in fuel costs and hot water consumption, deliming has become a necessity of modern maintenance. Lime ( $\text{CaCO}_3$ ), is the most notable factor when discussing water hardness. Lime is present in every water system to some degree. Since lime is inversely soluble (the more you heat, the more lime comes out), higher usage, excessive hardness, and increased heating surface can lead to a high incidence of “limed-up” heaters. Symptoms often include a popping of water trapped under lime deposits or the sizzling of water trapped next to elements, boiling it to steam. |
| THE FIX          | Treatment of a “limed-up” heater is relatively simple. Since $\text{CaCO}_3$ is a base, the easiest way to dissolve it so it can be flushed from the heater is with an acid. The most commonly used is phosphoric acid at a food-grade level. Two available treatments are Mag-Erad® and Un-Lime®. Any well stocked plumbing supply house should have a deliming solution available. The directions on the product should be followed explicitly.  |

| CONDENSATION |   |
|--------------|---|
| SYMPTOMS     | The water heater appears to be releasing water while the main burner is on or water is found surrounding the heater shortly after the water heater has been used. This section explains why flue gases condense and how you can differentiate between condensation and leaking.   |
| CAUSES       | Condensate is the result of air borne water vapor being chilled below the dew point. The dew point is the temperature at which water vapor turns into liquid. Low incoming water temperatures cool the piping and the heat transfer surfaces of the water heater. When the main burner comes on, the hot flue gases turn into condensate upon contact with these surfaces. The typical home water heater will produce about one-half gallon of water vapor during every hour of operation. Condensate is often mistaken for leaking. Newer heaters will condensate more than older heaters because modern water heaters are much more efficient than their predecessors. The newer heaters utilize as much of the energy out of the main burner flame as possible. This lowers the flue gas and tank storage temperature and closer to the dew point temperature. |
| THE FIX      | To distinguish between a condensing water heater and a leaking water heater: <ol style="list-style-type: none"> <li>1. Wipe up any water under the heater,</li> <li>2. Turn gas control switch to the "OFF" position,</li> <li>3. Wait 8 hours, check for water accumulation under the heater.</li> <li>4. Condensation should stop when the entire tank water is heated above approximately 115°F. <ol style="list-style-type: none"> <li>a. If no water is under the heater, the water heater was condensing.</li> <li>b. If water is under the heater, check further for a loose fitting. If all fittings are tight and the tank is leaking, replace the water heater. Leaking heaters cannot be "repaired".</li> </ol> </li> </ol>  |

| DISCOLORED WATER |  |
|------------------|--|
| SYMPTOMS         | Rusty, brown, black, or yellow water appearing in the hot water.   |
| CAUSES           | Complaints of discolored water are commonly blamed on water heaters and storage tanks, but in fact, it is a rare occurrence for today's high quality glass lined tanks to have a lining failure significant enough to allow water to contact enough bare metal to discolor the contents of even a small tank. The most common cause of "rusty" water is a non-toxic iron reducing bacteria, scientifically termed Crenothrix, Leptothrix, and Gallionella. Iron bacteria is commonly found in soil, water wells, water treatment plants and water distribution piping systems where soluble iron exceeds 0.2 ppm, higher levels make conditions even more favorable. Soluble iron in the water provides food for the bacteria. Rusty discolored water is the end result of the bacteria feeding process. Water heaters and storage tanks usually require new anode rods as presence of iron bacteria contributes to premature anode failure. <p>The requirements for the bacteria to thrive are:</p> <ul style="list-style-type: none"> <li>• Elevated levels of iron and manganese in the water.</li> <li>• Water with little or no dissolved oxygen.</li> <li>• Temperatures below 138°F.</li> </ul> <p>Items that can increase the potential for this bacteria are:</p> <ul style="list-style-type: none"> <li>• Water softeners.</li> <li>• Well water.</li> <li>• Long periods of no water movement.</li> </ul> |
| TREATMENT        | The simplest treatment available is shock-chlorination of the system. This is a surface treatment, and often requires repeated trials in heavily infected systems. The chlorination of a system requires that you follow each step explicitly to avoid an untreated portion of the piping system from re-infecting another part. See the <b>Chlorination Procedure</b> (page 31).  |
| NOTES            | Since rusty water is caused by a bacteria presence and is not caused by the water heater, any treatment would not be considered warranty related.  |

## SMELLY WATER

|           |   |
|-----------|---|
| SYMPTOMS  | Rusty, brown, black, or yellow water appearing in the hot water.  |
| CAUSES    | <p>The most common cause of “smelly water” is a non-toxic sulfate reducing bacteria, scientifically termed <i>Divibrio Sulfurcans</i>. This bacteria often enters the water system through construction or a break in ground piping. The bacteria create the energy it needs to survive by converting sulfate (SO<sub>4</sub>) to hydrogen sulfide (H<sub>2</sub>S) gas you smell in the water. Hydrogen sulfide gas is distinctive because of its rotten egg-like stench. Its presence can severely affect the taste as well as the odor of the water. Occasionally this bacteria can be accompanied by black deposits, the result of pipe and fitting corrosion. In extremely high concentrations, hydrogen sulfide gas can be toxic though the gas is detectable long before harmful levels are reached.</p> <p>The requirements for the bacteria to thrive are:</p> <ul style="list-style-type: none"> <li>• Elevated levels of iron and manganese in the water.</li> <li>• Water with little or no dissolved oxygen.</li> <li>• Temperatures below 138°F.</li> </ul> <p>Items that can increase the potential for this bacteria are:</p> <ul style="list-style-type: none"> <li>• Water softeners.</li> <li>• Well water.</li> <li>• Long periods of no water movement.</li> </ul> <p>Other factors that may contribute to smelly water:</p> <ul style="list-style-type: none"> <li>• Chlorides of Magnesium and Calcium leave a bitter taste.</li> <li>• Chloride of Sodium produces a salty taste.</li> <li>• Sulfates (50 ppm) gives a medicinal taste.</li> <li>• Carbon Dioxide in low pH water gives fizzy water.</li> <li>• Iron and tannic waters also give a bad taste and odor.</li> </ul> |
| TREATMENT | The simplest treatment available is the shock-chlorination of the system. This is a surface treatment, and often requires repeated trials in heavily infected systems. The chlorination of a system requires that you follow each step explicitly to avoid an untreated portion of the piping system from re-infecting another part. See the <b>Chlorination Procedure</b> (page 31). Longer lasting solutions include chlorination or aeration of the water supply.  |
| NOTES     | Since rusty water is caused by a bacteria presence and is not caused by the water heater, any treatment would not be considered warranty related.   |



| CHLORINATION PROCEDURE |   |
|------------------------|---|
| CAUSES                 | The chlorination procedure is used to eliminate various bacteria that accumulate and grow in water heaters. These bacteria often cause odorous or discolored water conditions.  |
| TREATMENT              | The simplest treatment available is the shock-chlorination of the system. This is a surface treatment, and often requires repeated trials in heavily infected systems. The chlorination of a system requires that you follow each step explicitly to avoid an untreated portion of the piping system from re-infecting another part. Longer lasting solutions include chlorination or aeration of the water supply. |
| PROCEDURE              | Please read the steps of the chlorination procedure prior to beginning. If you feel uncomfortable performing any of these steps, contact a service person to perform this procedure for you.  |
| STEP 1                 | Turn off the gas and electric supply to the tank.   |
| STEP 2                 | Turn off the cold water supply valve to the tank.   |
| STEP 3                 | Open a nearby hot water faucet to relieve the vacuum.   |
| STEP 4                 | Drain all the water from the tank (a water-hose may be needed).   |
| STEP 5                 | Remove the anode rod(s), and close the drain valve.   |
| STEP 6                 | Using a funnel in the anode opening add one gallon of household chlorine bleach for every 25 gallons of tank capacity.  |
| STEP 7                 | Reinstall anode rod(s) after inspecting and replacing as needed.  |
| STEP 8                 | Open cold water supply valve and refill the system. Then draw the water to every hot water fixture, until the smell of chlorine is detected. Operate dish and clothes washers until a noticeable amount of the chlorine is detected as well. All hot water lines must receive treatment.  |
| STEP 9                 | Leave the chlorine solution undisturbed for one hour or more.   |
| STEP 10                | After the contact time has elapsed, drain the tank according to steps 2, 3, & 4.  |
| STEP 11                | Close the drain valve and refill the tank. Allow the tank to sit for 15 minutes. Repeat steps 2, 3, and 4. Continue to flush the tank if the water is discolored or contains a chlorine odor.   |
| STEP 12                | Close the drain valve and refill the tank. Flush all chlorine from the piping by opening every hot water outlet/appliance.  |
| STEP 13                | Return hot water heating system to service by following the recommended start-up procedure posted on the unit or in the <i>Manual</i> .   |

| NOT ENOUGH HOT WATER |  |
|----------------------|--|
| CAUSES               | <ul style="list-style-type: none"> <li>• The heating capacity of the water heater has been exceeded: complaints regarding an insufficient supply of hot water are typically the result of a water heater that cannot meet the demands of the residence (both people and appliances). The demand for sufficient hot water may also be exceeded if additional people and/or appliances are added to the residence.</li> <li>• Operating Set Point is too low.</li> <li>• Mineral build-up.</li> <li>• Hot water supply valve(s) to fixtures not fully open.</li> <li>• Inlet/outlet water piping connections to water heater reversed.</li> <li>• Dip tube inside water inlet connection missing.</li> </ul> |
| THE FIX              | <p>Compare hot water requirements with the capacity of the water heater. If necessary, install a water heater with greater capacity.</p> <ul style="list-style-type: none"> <li>• Turn temperature knob to desired temperature as described in the <i>Manual</i>.</li> <li>• Drain the tank. (See <i>Draining and Flushing</i> in the <i>Manual</i>). Determine if water treatment is needed.</li> <li>• Check to see if hot water supply valve is fully open, check inlet/outlet piping connections to water heater are not reversed, check to see if the dip tube inside water inlet connection is not missing.</li> </ul>   |

## THERMAL EXPANSION

|          |  |
|----------|--|
| SYMPTOMS | <ul style="list-style-type: none"> <li>• Effects are only noticeable after hot water use followed by periods of no water use.</li> <li>• Relief valve drips during any recovery cycle when no hot or cold water is used.</li> <li>• Hot water pipes creak while water heater is recovering and all valves are closed.</li> <li>• Tanks or other components of the water supply system fail prematurely.</li> <li>• A metallic creaking noise might actually be heard in the location of the heater as the pressure is relieved and the stretched tank returns to a natural shape.</li> <li>• Faucet drips during any recovery cycle when no hot or cold water is used.</li> <li>• Water surges when a faucet is first opened and then pressure drops.</li> </ul>   |
| CAUSE    | <p>The water in a water heating system expands when it is heated and increases in volume. Since water will not compress (like air), system designers must include provisions for thermal expansion. (Water in a closed tank at 50 psi, when heated just 10 degrees, will reach a pressure of 250 psi). Many water supply systems have check valves or back flow preventers at the water meter to prevent any possible contamination of the public water supply by the accidental back-flow of contaminated water into the supply mains. These check valves are often required by code, and some cities are even installing the check valves. They serve a useful purpose. Do not remove them! The use of pressure reducing valves (PRV) is another cause. PRVs are designed to conserve water and prolong fixture life. Many PRVs also act as very effective check valves. Again, do not remove them! Water softeners in the system may also act as back-flow preventers.</p>  |
| TEST     | <p>Follow these easy steps to diagnose thermal expansion:</p> <ul style="list-style-type: none"> <li>• Turn gas control switch to the “OFF” position, and install a water pressure gauge with dead hand on the drain valve. Open the drain valve, so the gauge reads system pressure.</li> <li>• Open a hot water tap and allow 15% to 20% of the tanks volume to run out. Shut off the drain valve and make sure that no other fixture in the system, hot or cold, is open. Make sure that outside fixtures, if they are on the same system, are turned off too. Any water leaks or use will make the test meaningless.</li> <li>• Check the water pressure gauge, and turn the pointer so it lines up with the pressure indicating needle. Turn the gas control switch “ON”, so the heater cycles on. Watch the pressure gauge.</li> <li>• If the system is closed, the pressure will start to climb steadily and rapidly. A small amount of thermal expansion control may be built into the system because of trapped air pockets or a water hammer arrestor. In that case the pressure will increase slightly, hold steady for a short time and then rapidly increase. The temperature and pressure relief valve (T&amp;P) or PRV should open and release water once the pressure reaches the maximum setting on the valve. The valve will close once the pressure falls below the pressure setting of the valve.</li> </ul> |
| THE FIX  | <p>The ideal fix involves the use of a pressure reducing valve if supply pressures are above 60 to 70 psi, and a properly sized expansion tank. The PRV reduces supply pressures to 40 to 60 psi allowing an economically priced and sized expansion tank to be used. The PRV also offers the benefit of saving water and prolonging the life of water flow valves. The PRV is not required if the system already has one or if high supply pressures are desired. A supply water pressure of 80 PSI is a maximum set by many codes. The PRV is installed between the check valve and the water heating system. The expansion tank is installed between the PRV and the water heating system. Follow the manufacturers instructions for installing the expansion tank. Run the thermal expansion check again. The pressure should increase only slightly then hold steady throughout the recovery cycle. The expanded water is flowing back from the heater and into the pressurized storage bladder of the expansion tank. Air pressure will force this water out of the expansion tank into the supply once usage resumes. <b>DO NOT DEPEND ON THE TEMPERATURE &amp; PRESSURE VALVE (T&amp;P VALVE) TO HANDLE THERMAL EXPANSION!</b> The T&amp;P valve manufacturers designed the valve to be an emergency relief device only. The T&amp;P Valve could be subject to reduced effectiveness or failure.</p>                     |
| WARNING  | <p>Thermal expansion of water, if not compensated for in system design, will lead to the early failure of components. These failures are not covered by the manufacturer’s warranty, so it is extremely important that everyone be aware of the causes, symptoms and solutions to thermal expansion in a closed water heating system.</p>  |

## LEAKING TEMPERATURE AND PRESSURE RELIEF VALVE

|          |  |
|----------|--|
| SYMPTOMS | <ul style="list-style-type: none"> <li>• Water seeping around the relief valve tank connection.</li> <li>• Leakage at the threaded portion of the relief valve connection.</li> <li>• Intermittent weeping and/or dribbling from the relief valve.</li> <li>• Large volume of hot water sporadically discharged from the relief valve.</li> </ul>  |
| CAUSE    | <p>The temperature and pressure relief valve (T&amp;P) is a safety device limiting temperature and pressure levels in a water heater. Each T&amp;P has both a temperature and pressure rating. Normally, the temperature and pressure relief valve will have a temperature rating of 210°F. A probe (part of the relief valve) extends into the tank measuring the stored water temperature. This probe must be within the top six inches of the water heater. If the water heater's thermostat malfunctions, higher than normal water temperatures could be produced. Once the probe senses a temperature approaching its temperature rating, the relief valve will open to full capacity releasing "very hot" water until the temperature is below its reset temperature. The pressure rating on the relief valve should be the same or less than the certified working pressure of the tank (generally 150 psi) and be below the lowest maximum working pressure rating of any system components. Once the pressure in the tank reaches the valve's pressure rating, it will slightly open relieving the pressure. Relieving of pressure can be noted as "dribbling" or "weeping" water from the relief valve. If an incorrectly sized temperature and pressure relief valve is installed, the warranty will be void.</p> |
| THE FIX  | <p>Follow these easy steps to diagnose thermal expansion:</p> <ul style="list-style-type: none"> <li>• Intermittent weeping and/or dribbling at the relief valve - The relief valve relieves water slowly when actuating on pressure. A closed system can cause pressure to increase in the system. This condition is called thermal expansion. For additional information regarding thermal expansion please see <i>Thermal Expansion</i> the <i>Manual</i>.</li> <li>• Leaking at the spud of the water heater - Spuds are welded to the tank and are not repairable. The heater should be replaced.</li> <li>• Leakage at the threaded relief valve connection - Remove relief valve and reseal connection.</li> <li>• Large volume of hot water sporadically discharged from the relief valve – The relief valve relieves water quickly when actuating on temperature. The only cause of this problem is a malfunctioning thermostat.</li> </ul>   |

## INSULATION BLANKETS

|         |   |
|---------|---|
| GENERAL | <p>The purpose of an insulation blanket is to reduce the standby heat loss encountered with storage tank heaters. Most modern water heaters have adequate factory installed insulation, the use of an after market insulation blanket is no longer recommended by most experts. While the use of an external insulation blanket will not void the warranty, the water heater manufacturer explicitly disclaims any liability for problems associated with the use of insulation blankets.</p> <p><b>Note:</b> New local energy codes may still require the use of insulation blankets on waters heaters. Be sure to follow all installation instructions, cautions, and warnings for the insulation blanket as well as the cautions and warning of the water heaters owners <i>Manual</i>.</p>  |
| NOTES   | <p>Should you choose to apply an insulation blanket to this heater, you should follow these instructions. Failure to follow these instructions can restrict the air flow required for proper combustion, resulting in fire, asphyxiation, serious personal injury or death.</p> <ul style="list-style-type: none"> <li>• Do not cover the outer door, thermostat or temperature &amp; pressure relief valve.</li> <li>• When installed the insulation blanket will cover important safety and operation labels. Obtain new warning and instruction labels from the Technical Information Center listed in the owners' <i>Manual</i>. The replacement labels must be placed on the blanket in the location of the original labels on the water heater jacket.</li> <li>• Do not cover the instruction <i>Manual</i>. Keep it on the side of the water heater or nearby for future reference.</li> <li>• Do not apply insulation to the top of the water heater, as this will interfere with safe operation of the draft hood.</li> <li>• Do not allow insulation to come within 2" of the rear air duct of the water heater to prevent blockage of combustion air flow to the burner. The combustion air openings in the rear air duct of the water heater must NOT be obstructed.</li> <li>• Inspect the insulation blanket frequently to make certain it does not sag, thereby obstructing combustion air flow.</li> </ul> |

## TROUBLESHOOTING CHART

| PROBLEM                                      | POSSIBLE CAUSE(S)   | CORRECTIVE ACTION   |
|--|---|---|
| BURNER FLAME TOO HIGH                        | <ol style="list-style-type: none"> <li>1. Insufficient secondary air</li> <li>2. Orifice too large</li> </ol>   | <ol style="list-style-type: none"> <li>1. Provide ventilation to water heater.</li> <li>2. Replace with correct orifice.</li> </ol>   |
| FLAME BURNS AT ORIFICE                       | <ol style="list-style-type: none"> <li>1. Low gas pressure</li> <li>2. Defective gas control (thermostat)</li> </ol>  | <ol style="list-style-type: none"> <li>1. Check with gas utility company.</li> <li>2. Replace gas control (thermostat).</li> </ol>  |
| INSUFFICIENT HOT WATER                       | <ol style="list-style-type: none"> <li>1. Low gas pressure</li> <li>2. Orifice too small</li> <li>3. Thermostat set too low</li> <li>4. Gas control error codes</li> <li>5. Sediment or lime in tank</li> <li>6. Water heater too small</li> <li>7. Wrong piping connections</li> <li>8. Leaking faucets</li> <li>9. Wasted hot water</li> <li>10. Long runs of exposed piping</li> <li>11. Hot water piping in outside wall</li> </ol> | <ol style="list-style-type: none"> <li>1. Check with gas utility company.</li> <li>2. Replace with correct orifice.</li> <li>3. Turn temperature knob to higher setting.</li> <li>4. See the gas control error code in the <i>Manual</i>.</li> <li>5. Drain/flush-provide water treatment if needed.</li> <li>6. Install adequate heater.</li> <li>7. Correct piping: dip tube must be in cold inlet.</li> <li>8. Repair faucets.</li> <li>9. Advise customer.</li> <li>10. Insulate piping.</li> <li>11. Insulate piping.</li> </ol> |
| WATER IS TOO HOT                             | <ol style="list-style-type: none"> <li>1. Thermostat is too high</li> <li>2. Defective gas control (thermostat)</li> </ol>  | <ol style="list-style-type: none"> <li>1. Turn temperature knob to lower setting.</li> <li>2. Replace the gas control (thermostat).</li> </ol>  |
| SLOW HOT WATER RECOVERY                      | <ol style="list-style-type: none"> <li>1. Insufficient secondary air</li> <li>2. Low gas pressure</li> <li>3. Orifice too small</li> <li>4. Thermostat set too low</li> <li>5. Heater too small</li> <li>6. Wrong piping connection</li> <li>7. Wasted hot water</li> <li>8. Flue clogged</li> </ol>  | <ol style="list-style-type: none"> <li>1. Provide ventilation to water heater. Check flue way, flue baffle and burner.</li> <li>2. Check with gas utility company.</li> <li>3. Replace with correct orifice.</li> <li>4. Turn temperature knob to higher setting.</li> <li>5. Install adequate heater.</li> <li>6. Correct piping-dip tube must be in cold inlet.</li> <li>7. Advise customer.</li> <li>8. Clean flue, locate source and correct.</li> </ol>  |
| DRIP FROM RELIEF VALVE                       | <ol style="list-style-type: none"> <li>1. Pressure build-up</li> <li>2. Heater stacking</li> <li>3. Closed water system</li> <li>4. Improperly seated valve</li> </ol>  | <ol style="list-style-type: none"> <li>1. Use a pressure reducing valve and relief valve.</li> <li>2. Lower the thermostat setting.</li> <li>3. See <i>Thermal Expansion</i> in the <i>Manual</i>.</li> <li>4. Check Relief valve for proper operation. (Do Not plug T&amp;P valve.)</li> </ol>   |
| GAS CONTROL/<br>THERMOSTAT FAILS TO SHUT OFF | <ol style="list-style-type: none"> <li>1. Defective gas control (thermostat)</li> </ol>   | <ol style="list-style-type: none"> <li>1. Replace gas control (thermostat).</li> </ol>  |
| SMELLY WATER                                 | <ol style="list-style-type: none"> <li>1. Sulfides in water supply</li> <li>2. Bacteria in water supply</li> </ol>  | <ol style="list-style-type: none"> <li>1. See <i>Smelly Water</i> in the <i>Manual</i>.</li> <li>2. See <i>Smelly Water</i> in the <i>Manual</i>.</li> </ol>  |
| CONDENSATION                                 | <ol style="list-style-type: none"> <li>1. Filling the new water heater for the first time</li> <li>2. Moisture from the products of combustion</li> <li>3. Water dripping from blower assembly</li> <li>4. Undersized water heater</li> </ol>   | <ol style="list-style-type: none"> <li>1. Normal operation: the condensation should disappear after heater warms up.</li> <li>2. Normal operation: the condensation should disappear in time.</li> <li>3. Provide drip "TEE" to the horizontal section of exhaust vent close to blower assembly.</li> <li>4. Install adequate heater.</li> </ol>  |
| COMBUSTION ODORS                             | <ol style="list-style-type: none"> <li>1. Insufficient secondary air</li> <li>2. Flue clogged</li> <li>3. Heater installed in a confined area</li> <li>4. House too tight</li> </ol>  | <ol style="list-style-type: none"> <li>1. Provide fresh air ventilation to the water heater.</li> <li>2. Clean, locate source and correct.</li> <li>3. Provide fresh air ventilation to the water heater.</li> <li>4. Provide fresh air ventilation to the water heater.</li> </ol>   |

| PROBLEM  | POSSIBLE CAUSE(S)  | CORRECTIVE ACTION  |
|--|--|--|
| SMOKING AND CARBON FORMATION                             | <ol style="list-style-type: none"> <li>1. Insufficient secondary air</li> <li>2. Low gas pressure</li> <li>3. Orifice too large</li> <li>4. Flue clogged</li> <li>5. Defective gas control (thermostat)</li> <li>6. Heater installed in a confined area</li> </ol>   | <ol style="list-style-type: none"> <li>1. Provide ventilation to water heater. Check flue way, flue baffle and burner.</li> <li>2. Check with gas utility company.</li> <li>3. Replace with correct orifice.</li> <li>4. Clean, locate source and correct.</li> <li>5. Replace gas control (thermostat).</li> <li>6. Provide fresh air ventilation.</li> </ol>   |
| UNABLE TO LIGHT THE BURNER                               | <ol style="list-style-type: none"> <li>1. Air in gas line</li> <li>2. Pressure switch</li> <li>3. Blocked exhaust</li> <li>4. Wire connection</li> <li>5. Defective gas control (thermostat)</li> </ol>  | <ol style="list-style-type: none"> <li>1. Purge the air from gas line.</li> <li>2. Check the pressure switch, make sure the pressure switch hose is not kinked.</li> <li>3. Check vent pipe for blockage.</li> <li>4. Check wire connections.</li> <li>5. Replace the gas control (thermostat).</li> </ol>   |
| SIZZLING, RUMBLING NOISE                                 | <ol style="list-style-type: none"> <li>1. Scale and sediment</li> <li>2. Condensation dripping on burner</li> </ol>  | <ol style="list-style-type: none"> <li>1. Drain/flush-provide water treatment if needed.</li> <li>2. See <i>Strange Sounds</i> in the <i>Manual</i>.</li> </ol>  |
| WATER LEAKAGE  | <ol style="list-style-type: none"> <li>1. Condensation</li> <li>2. Dripping Temperature &amp; Pressure Relief Valve</li> <li>3. Thermostat does not shut-off</li> <li>4. Drain valve dripping/leaking</li> <li>5. Tank Leak</li> </ol>   | <ol style="list-style-type: none"> <li>1. See <i>Condensate</i> in the <i>Manual</i>.</li> <li>2. See <i>Temperature &amp; Pressure Relief Valve</i> in the <i>Manual</i>.</li> <li>3. Check the Thermostat.</li> <li>4. Back flush to clean out sediment, replace if necessary.</li> <li>5. See <i>Leakage Checkpoints</i> (page 5).</li> </ol>   |
| BLOWER WILL NOT START                                    | <ol style="list-style-type: none"> <li>1. No power to unit</li> <li>2. Thermostat set too low</li> <li>3. Defective air pressure switch</li> <li>4. Defective blower</li> <li>5. Disconnected or loose wire</li> <li>6. Control locked out</li> </ol>  | <ol style="list-style-type: none"> <li>1. Plug in power cord, check fuses and/or supply voltage.</li> <li>2. Turn temperature knob to higher setting.</li> <li>3. Replace air pressure switch.</li> <li>4. Replace blower.</li> <li>5. Repair and reconnect wires.</li> <li>6. Reset – determine cause of lockout.</li> </ol>  |
| BLOWER RUNS CONTINUOUSLY                                 | <ol style="list-style-type: none"> <li>1. Air pressure switch not closing due to insufficient draft – check for: <ol style="list-style-type: none"> <li>a. Vent piping blocked</li> <li>b. Piping length too long</li> <li>c. Clogged/dirty blower</li> </ol> </li> <li>2. Disconnected, torn or blocked pressure switch hose from air pressure switch to blower housing</li> <li>3. Defective pressure switch</li> <li>4. High limit switch open due to excessive vent temperature or defective switch</li> </ol> | <ol style="list-style-type: none"> <li>1. Determine cause of insufficient draft. Check draft with manometer at pressure switch (See <i>Table 1</i> in the <i>Manual</i> for minimum acceptable draft setting). <ol style="list-style-type: none"> <li>a. Remove blockage.</li> <li>b. Reduce vent length/increase vent size.</li> <li>c. Clean blower wheel.</li> </ol> </li> <li>2. Reconnect or replace pressure switch hose</li> <li>3. Replace defective pressure switch.</li> <li>4. Determine cause of overheating check for: over-firing, insufficient air supply, high ambient air temperature (once high limit switch activated, must be replaced)</li> </ol> |
| HOT SURFACE IGNITER NOT GLOWING FOLLOWING WARM-UP PERIOD | <ol style="list-style-type: none"> <li>1. Defective hot surface igniter</li> <li>2. Defective gas control (thermostat)</li> </ol>  | <ol style="list-style-type: none"> <li>1. Replace igniter</li> <li>2. Replace gas control (thermostat)</li> </ol>  |
| VENT PIPE TOO HOT (ABOVE 170°F)                          | <ol style="list-style-type: none"> <li>1. Blower does not run when heater fired</li> <li>2. Not enough dilution air to mix with flue gases</li> <li>3. Air in room too hot for mixing with flue gases</li> <li>4. Wrong burner orifice</li> </ol>  | <ol style="list-style-type: none"> <li>1. See “BLOWER WILL NOT START” problem</li> <li>2. Proper air circulation must be provided for combustion and dilution of flue temp</li> <li>3. Room air to be used for dilution with combustion products in flue should be less than 90°F</li> <li>4. Install correct orifice</li> </ol>   |

## GAS CONTROL LED STATUS CODES

| LED Flash Sequence                       | Control Status                                       |
|--|--|
| Short flash<br>once every four seconds   | IDLE (no call for heat,<br>no fault conditions)      |
| “Heartbeat”,<br>alternates bright/dim    | Call For Heat<br>(no fault conditions)               |
| One Flash,<br>three second pause         | Low Flame Signal<br>(control continues to operate)   |
| Two Flash,<br>three second pause         | Pressure Switch Failed Closed                        |
| Three Flash,<br>three second pause       | Pressure Switch Failed Open                          |
| Four Flash,<br>three second pause        | TCO Limit Lockout                                    |
| Five Flash,<br>three second pause        | Flame Out Of Sequence                                |
| Six-One Flash,<br>three second pause     | Soft Lockout<br>– Retry Limit<br>- Failed TFI        |
| Six-Two Flash,<br>three second pause     | Soft Lockout<br>- Recycle Limit<br>- PS/Limit opened |
| Six-Three Flash,<br>three second pause   | Soft Lockout<br>- Recycle Limit<br>- Flame Lost      |
| Six-Four Flash, three second pause       | Soft Lockout<br>- Flame out of Sequence Sensed       |
| Seven Flash,<br>three second pause       | Flammable Vapor Sensor Lockout                       |
| Eight-One Flash,<br>three second pause   | FVS Fault Detected                                   |
| Eight-Two Flash,<br>three second pause   | Temperature Sensor Fault Detected                    |
| Eight-Three Flash,<br>three second pause | Electronics Fault Detected                           |
| Eight-Four Flash,<br>three second pause  | Valve Fault Detected                                 |

## IGNITION STATE AND TIMING

| IGNITION STATE                         | TIMING  |
|--|---|
| Pre-purge                              | 5 seconds (NG models)                                     |
|  | 15 seconds (LP models)                                    |
| HSI Warmup                             | 10 seconds  |
| Ignition Activation Period (IAP)       | 3.5 seconds maximum                                       |
| Flame Recognition Period (FRP)         | 0.5 second  |
| Trial For Ignition                     | IAP + FRP   |
| Flame Stabilization Period             | Not Applicable  |
| Inter-purge                            | 30 seconds  |
| Flame Failure Response Time            | 2 seconds max<br>(@ 1uA flame current)                    |
| Post-purge                             | 30 seconds  |
| PS Prove Period                        | 2 minutes   |
| PS Fault Delay<br>(failed open/closed) | 2 minutes   |
| Soft Lockout                           | 20 minutes  |
| TCO Limit Lockout                      | Indefinite (follow defined procedure to restart)          |
| Flammable Vapor Sensor Lockout         | Indefinite (follow defined procedure to restart)          |
| Hardware Fault Lockout                 | Indefinite (clear fault to restart in 15 seconds or less) |







300 Maddox Simpson Parkway

Lebanon, TN 37090

Phone: 1-800-722-2101 • Fax: 615-547-1000

Technical Service email: [2tech@lochinvar.com](mailto:2tech@lochinvar.com)

[www.Lochinvar.com](http://www.Lochinvar.com)

Copyright © 2019 Lochinvar, LLC. All rights reserved.